

Comfort and Energy Savings.

An Unbeatable Combination!



95% Gas Furnace

Comfort-Cure®
HEAT CONTROLLER

Comfort, efficiency, and dependability make an unbeatable combination in the 95% gas furnace!



Energy Savings

Two heat exchangers make this one of the most efficient furnaces on the market today. The primary exchanger pulls about three-quarters of the available heat from the burner, then the secondary heat exchanger captures most of what's remaining. Using 95% or more of the heat output from each cubic foot of gas, this furnace produces not just greater comfort, but also significant fuel savings.

A Perfect Fit

At only 34 ½" in height, the furnace is ideal for renovations and replacements. It will fit in virtually any space where a furnace was previously installed, including basements and utility closets. For contractors and architects, the low profile design is a distinct advantage, offering many placement options.

Simple Installation

Our 95% furnace comes assembled and pre-wired, with a color-coded wiring harness and quick connect fittings. An integrated control board simplifies hook-ups, and all components are easy to reach. Because of its small size, the furnace is a snap to load and unload on a truck or van, and easily fits through doors, halls and stairways.

Quiet Operation

Inherent in the proven design of the furnace are quality components that are not only dependable but that keep operational sound to a minimum. The blower compartment has a sealed insulated door, while a sealed vestibule reduces burner and inducer sound levels for clean, efficient, quiet combustion.

Outstanding Warranty

The primary and secondary heat exchangers are covered by a limited lifetime warranty; other components are covered for twelve years.

(Some limitations apply; see printed warranty for details.)

Reliability You Can Trust

Heat Controller, Comfort-Aire's parent company, has been in the furnace business since its founding in 1933—in fact, the company can trace its roots to the Wingert Furnace Co. which began building coal, gas and oil furnaces in 1907. Air conditioning equipment was later added to round out the product line.

Known today for efficient, reliable equipment for both heating and cooling, Comfort-Aire® continues to keep homes and businesses comfortable, season after season.



For year-'round comfort, ask your dealer about our line of central air conditioners—the perfect match for energy savings!

Upflow/Horizontal Specifications

GUH95A Models	-038B4	-054B4	-072C5	-090C5	-108D5	-120D5
Input-BTUH ¹	38,000	54,000	72,000	90,000	108,000	120,000
Heating Cap. BTUH	36,100	51,300	68,400	85,500	102,600	114,000
AFUE	95.0	95.0	95.0	95.0	95.0	95.0
Blower D x W	10 x 8	11 x 8	10 x 10	11 x 10	11 x 10	11 x 10
Motor HP/Speed/Type	1/2-4-PSC	1/2-4-PSC	1/2-4-PSC	1.0-4-PSC	1.0-4-PSC	1.0-4-PSC
Heating Speed*	Med-Low	Med-Low	Med-High	Med-High	Med-High	Med-High
Cooling Speed*	High	High	High	High	High	High
Motor FLA	8.60	8.60	8.0	13.75	13.75	13.75
Rated Ext. SP in W.C.	0.5	0.5	0.5	0.5	0.5	0.5
Temp. Rise Range °F	30-60	30-60	35-65	35-65	40-70	40-70
Shipping Weight (lbs/kg)	100/45.4	120/54.4	130/59	135/61.2	155/70.3	155/70.3

* Factory setting

¹Ratings to 2,000 ft. Over 2,000 ft, reduce 4% for each 1,000 ft. above sea level.

Gas connection for all models is 1/2" N.P.T.

GUH 95A- Model	Htg Input BTUH	Motor Speed	External Static Pressure (Inches Water Column)															
			0.1		0.2		0.3		0.4		0.5		0.6		0.7		0.8	
			CFM	Rise	CFM	Rise	CFM	Rise	CFM	Rise	CFM	Rise	CFM	Rise	CFM	Rise	CFM	Rise
-038B4	38K	High*	1664	18	1631	21	1596	21	1546	22	1489	23	1433	24	1366	25	1285	26
		Med Hi	1272	26	1255	27	1249	27	1217	28	1189	29	1145	30	1096	31	1036	33
		M-Low†	1130	29	1114	31	1100	31	1079	31	1048	33	1025	33	987	35	944	36
		Low	869	39	839	42	809	42	790	44	764	45	739	47	711	48	664	52
-054B4	54K	High*	1664	30	1631	31	1596	31	1546	32	1489	34	1433	35	1366	37	1285	39
		Med Hi	1272	39	1255	40	1249	40	1217	41	1189	42	1145	44	1096	46	1036	48
		M-Low†	1130	44	1114	45	1100	45	1079	46	1048	48	1025	49	987	51	944	53
		Low	869	58	839	60	809	62	790	63	764	65	739	68	711	70	664	75
-072C5	72K	High*	1916	35	1848	36	1773	38	1692	39	1613	41	1515	44	1426	47	1316	51
		Med Hi†	1815	37	1771	38	1711	39	1641	41	1533	43	1468	45	1373	49	1270	52
		M-Low	1259	53	1241	54	1224	54	1192	56	1063	57	1115	60	1056	63	982	68
		Low	1139	59	1120	60	1096	61	1075	62	1047	64	1014	66	959	70	884	75
-090C5	90K	High*	2273	37	2222	38	2164	39	2098	40	2052	41	1947	43	1864	45	1780	47
		Med Hi†	2084	40	2039	41	2007	42	1955	43	1895	44	1832	45	1750	48	1665	50
		M-Low	1784	47	1777	47	1749	48	1725	48	1679	50	1629	51	1576	53	1501	56
		Low	1482	56	1470	57	1444	58	1432	58	1405	59	1375	61	1339	62	1286	65
-108D5	108K	High*	2306	43	2247	45	2192	46	2121	47	2044	49	1979	51	1892	53	1787	56
		Med Hi†	2135	47	2103	50	2050	51	1995	53	1935	54	1858	57	1778	59	1690	62
		M-Low	1845	54	1834	57	1805	58	1776	59	1719	61	1663	63	1605	66	1533	69
		Low	1543	65	1521	69	1502	70	1477	71	1452	73	1412	75	1368	77	1314	80
-120D5	120K	High*	2306	48	2247	49	2192	51	2121	52	2044	54	1979	56	1892	59	1787	62
		Med Hi†	2135	52	2103	53	2050	54	1995	56	1935	57	1858	60	1778	62	1690	66
		M-Low	1845	60	1834	61	1805	62	1776	63	1719	65	1663	67	1605	69	1533	72
		Low	1543	72	1521	73	1502	74	1477	75	1452	77	1412	79	1368	81	1314	85

Notes for Upflow Blower Specifications

* Factory set cooling speed

† Factory set heating speed

NOTES:

1. Temperature rises in the table are approximate; actual temperature rises may vary.
2. Temperature rises in shaded areas are for reference only; these conditions are not recommended.
3. Two openings are recommended for airflows above 1600 CFM if filter(s) adjacent to furnace. Specifications shown for side return.

WARNING

THIS FURNACE IS NOT APPROVED OR
RECOMMENDED FOR USE IN MOBILE HOMES

Upflow/Horizontal Dimensions

95% Gas Furnace Upflow/Horizontal

GUH95A Models	A	B	C
-038B4	17 1/2	15 7/8	16 1/8
-054B4			
-072C5	21	19 3/8	19 5/8
-090C5			
-108D5	24 1/2	22 7/8	23 1/8
-120D5			

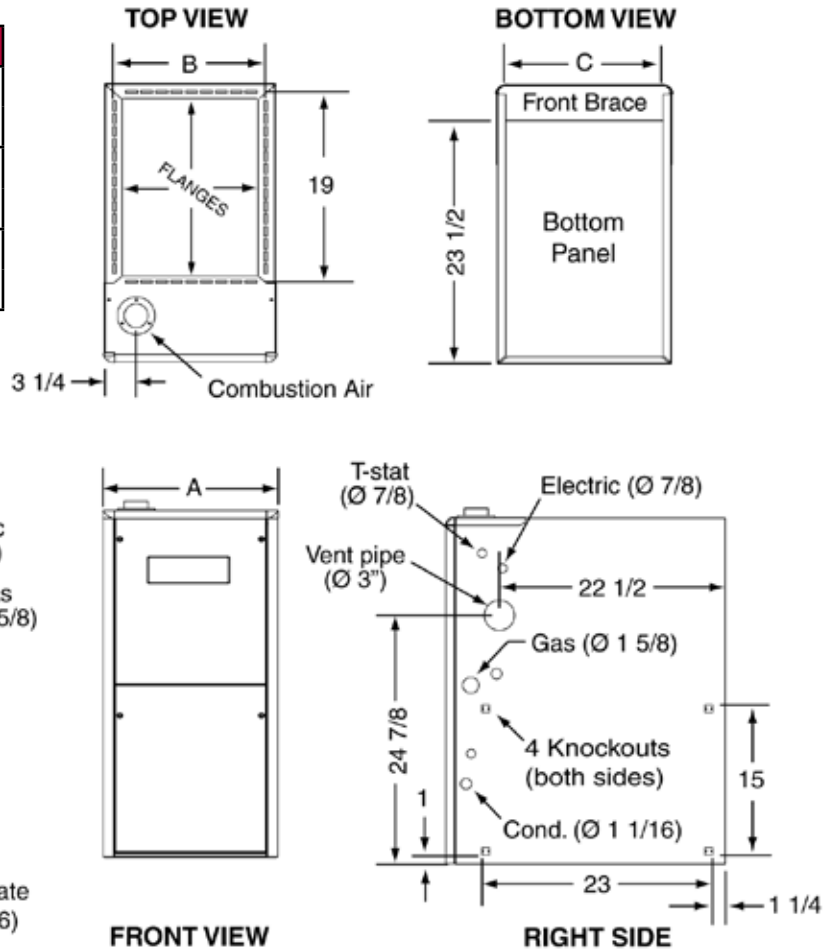

Model Nomenclature

G	UH	95	A	038	B	3	X	E
Gas Furnace	UH=Upflow/Horizontal DD=Dedicated Downflow UU = Upflow Only DH = Downflow/Horizontal	AFUE 95%	A=Single Stage/ Fixed Speed PSC	Heating Input BTUH 038=38,000 120=120,000	Cabinet Width A=14 1/2" B=17 1/2" C=21" D=24 1/2"	Max. CFM Cooling* 2 = 800 CFM 3=1200 CFM 4=1600 CFM 5=2000 CFM *Airflow @ 0.5 ESP or 400 CFM/ton	X=Low Nox	Series/ Revision

Category IV Venting: All models may be vertically or horizontally vented using either a one-pipe or two-pipe system. See the IOM for details.

Downflow Specifications

GDD95A Models	-054B4	-072C5	-090C5	-118D5
Input-BTUH ¹	54,000	72,000	90,000	118,000
Heating Cap. BTUH	51,300	68,400	85,500	112,100
AFUE	95.0	95.0	95.0	95.0
Blower D x W	11 x 8	11 x 10	11 x 10	11 x 10
Motor HP-Speed-Type	1/2-4-PSC	1.0-4-PSC	1.0-4-PSC	1.0-4-PSC
Heating Speed*	Med-Low	Med-High	Med-High	Med-High
Cooling Speed*	High	High	High	High
Motor FLA	8.60	13.70	13.70	13.75
Rated Ext. SP in W.C.	0.5	0.5	0.5	0.5
Temp. Rise Range °F	30-60	35-65	35-65	40-70
Shipping Weight (lbs/kg)	120/54.4	125/56.7	135/61.2	155/70.3

* Factory setting

Gas connection for all models is 1/2" N.P.T.

¹Ratings to 2,000 ft. Over 2,000 ft, reduce 4% for each 1,000 ft. above sea level.



WARNING
THIS FURNACE IS NOT APPROVED OR
RECOMMENDED FOR USE IN MOBILE HOMES

Blower Performance - Downflow

GDD 95A- Model	Htg Input BTUH	Motor Speed	External Static Pressure (Inches Water Column)															
			0.1		0.2		0.3		0.4		0.5		0.6		0.7		0.8	
			CFM	Rise	CFM	Rise	CFM	Rise	CFM	Rise	CFM	Rise	CFM	Rise	CFM	Rise	CFM	Rise
-054B4	54K	High*	1590	31	1563	32	1538	33	1513	33	1477	34	1430	35	1370	36	1312	38
		Med Hi	1228	41	1207	41	1193	42	1169	43	1157	43	1127	44	1084	46	1037	48
		M-Low†	1096	46	1079	46	1061	47	1038	48	1010	50	986	51	957	52	919	54
		Low	855	58	825	61	800	63	777	64	753	66	723	69	696	72	665	75
-072C5	72K	High*	2235	30	2176	31	2121	31	2067	32	2010	33	1936	34	1864	36	1783	37
		Med Hi†	2095	32	2052	32	2005	33	1957	34	1906	35	1852	36	1781	37	1709	39
		M-Low	1871	36	1838	36	1797	37	1761	38	1716	39	1667	40	1602	42	1536	43
		Low	1568	43	1552	43	1527	44	1485	45	1457	46	1418	47	1370	49	1343	50
-090C5	90K	High*	2208	38	2150	39	2089	40	2026	41	1959	43	1893	44	1825	46	1738	48
		Med Hi†	2065	40	2015	41	1970	42	1910	44	1866	45	1805	46	1737	48	1668	50
		M-Low	1802	46	1773	47	1750	48	1703	49	1670	50	1623	51	1556	54	1490	56
		Low	1490	56	1482	56	1464	57	1436	58	1407	59	1380	60	1329	63	1271	66
-118D5	118K	High*	2358	46	2299	48	2253	48	2191	50	2130	51	2060	53	1990	55	1903	57
		Med Hi†	2176	50	2135	51	2102	52	2046	53	1985	55	1932	57	1862	59	1777	61
		M-Low	1873	58	1852	59	1816	60	1790	61	1750	62	1699	64	1643	66	1571	70
		Low	1544	71	1528	72	1514	72	1499	73	1462	75	1441	76	1429	76	1386	79

* Factory set cooling speed

† Factory set heating speed

NOTE: 1. Temperature rises shown are approximate; actual temperature rises may vary.
2. Temperature rises in shaded areas are for reference only; these conditions are not recommended.
3. Two openings are recommended for airflows above 1600 CFM if filter(s) adjacent to furnace.
Downflow built with top return configuration.

NOTE: Furnace is not listed for use with fuels other than natural or L.P. (propane) gas.

All models can be converted by a qualified distributor or local service dealer to use L.P. (propane) gas. Factory approved kits must be used to convert from natural to L.P. (propane) gas and may be ordered as options.

For L.P. (propane) operation, refer to Conversion Kit instructions.

Downflow Dimensions

95% Gas Furnace Downflow

GDD95A Models	A	B	C
-054B4	17 1/2	15 7/8	16 1/8
-072C5			
-090C5	21	19 3/8	19 5/8
-118D5	24 1/2	22 7/8	23 1/8

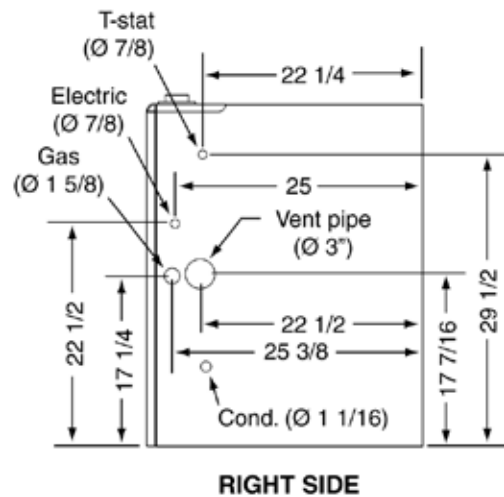
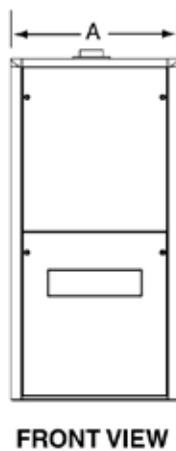
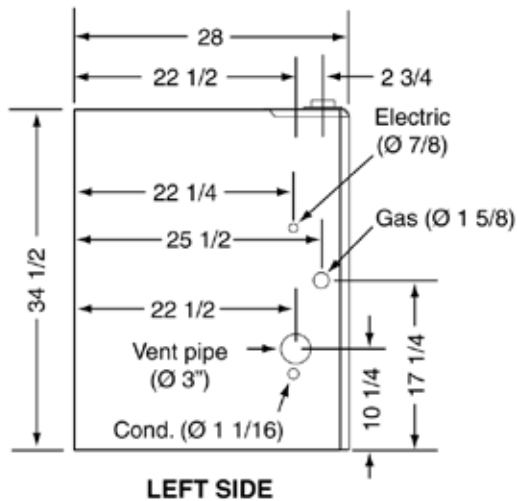
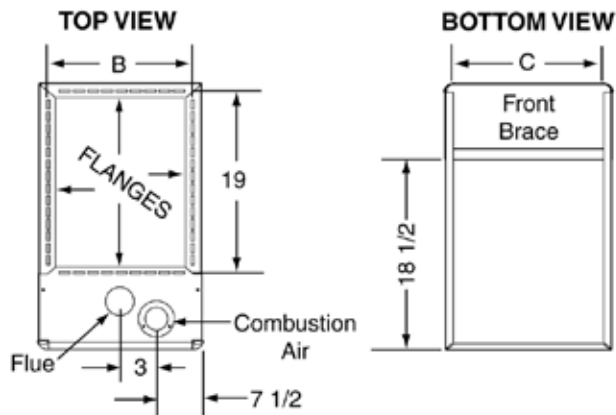

95% Single Stage Accessories

PART NO.	DESCRIPTION
904952	2" Concentric vent kit
904953	3" Concentric vent kit
904911	Downflow sub base kit
904617	2" Side wall vent kit
904347	3" Side wall vent kit
905028	U.S. LP conversion kit (0 - 10,000 ft.)
905029	Canada LP conversion kit (0 - 4500 ft.)
541036	Side return filter kit

PART NO.	DESCRIPTION
902377	Neutralizer kit
904873	Hi efficiency blower kit 17 1/2" - fixed speed
904874	Hi efficiency blower kit 21" - fixed speed
905875	Hi efficiency blower kit 24 1/2" - fixed speed
904877	Hi efficiency blower kit 17 1/2" - variable speed
904878	Hi efficiency blower kit 21" - variable speed
904879	Hi efficiency blower kit 24 1/2" - variable speed

IMPORTANT: Before proceeding with installation, refer to installation instructions packaged with each model, as well as complying with all Federal, State, Provincial, and Local codes, regulations, and practices.

Space Saving, Energy Saving Gas Heat Source

Primary Heat Exchanger

The tubular design extracts heat from combustion gases; made of heavy gauge aluminized steel, it's resistant to corrosion and thermal fatigue, and is covered by a limited lifetime warranty

Draft Inducer

Specially designed for the tubular heat exchanger, it pulls hot combustion gases through the exchanger; heated air is locked in while cold air is locked out

Efficient Blower

Multi-speed, high static blower delivers warm air throughout the house quietly and efficiently, for a wide range of cooling capacities

Low Profile Cabinet

Steel cabinet has corrosion-resistant finish; lightweight 34½" high design saves on space; upflow model is shown, two piece door has "captured" screws to prevent their loss

30 Second Blower Delay

The delay assures a warm duct temperature at furnace start-up; blower off settings can be adjusted to 60, 90 120 and 180 seconds

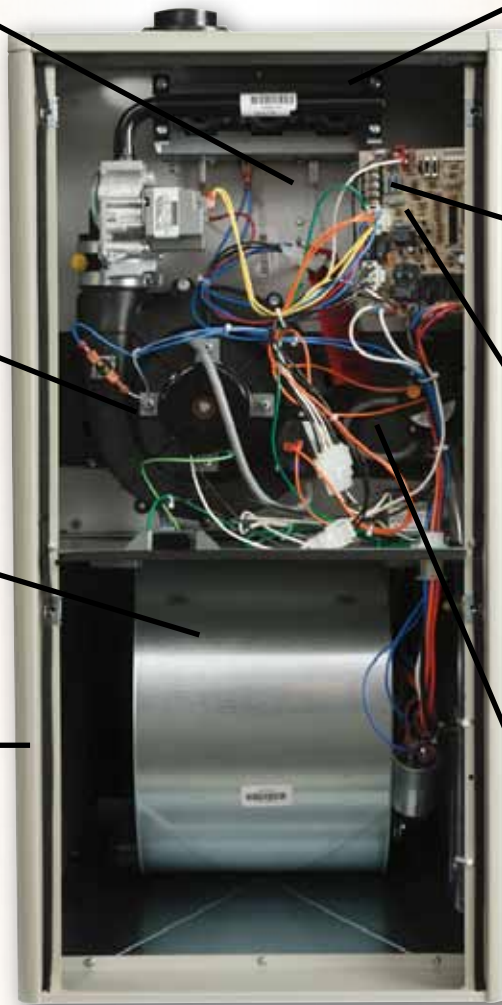

In-Shot Burner

Engineered to provide the most efficient air/gas mixture for combustion, the shutter-free design requires no adjustments to regulate the mix

Hot Surface Ignition

Silicon nitride type igniter is quiet and automatic, eliminating the need for a standing pilot light, while offering improved efficiency

Integrated Furnace Control (IFC)

Controls are integrated into one board set up for fast, easy installation, it includes connections for an electronic air cleaner and dehumidifier, and features on-board diagnostics with easy to recognize faults codes so there's no need to count flashes

Secondary Heat Exchanger

Made of stainless steel for durability, the secondary heat exchanger extracts additional heat (which would be lost by less efficient furnaces); it is covered by a limited lifetime warranty



Can be converted to LP gas by qualified contractor using a conversion kit shown in "Accessories" on page 6.

NOTE: Upflow model shown. Downflow models feature the same components in a different configuration.

Horizontal installation is for right side only with air supply on the left.

Upflow Models	Input BTUH	Heating Cap. BTUH	AFUE
GUH95A038B4	38,000	36,100	95.0%
GUH95A054B4	54,000	51,300	95.0%
GUH95A072C5	72,000	68,400	95.0%
GUH95A090C5	90,000	85,500	95.0%
GUH95A108D5	108,000	102,600	95.0%
GUH95A120D5	120,000	114,000	95.0%

Downflow Models	Input BTUH	Heating Cap. BTUH	AFUE
GDD95A054B4	54,000	51,300	95.0%
GDD95A072C5	72,000	68,400	95.0%
GDD95A090C5	90,000	85,500	95.0%
GDD95A118D5	118,000	112,100	95.0%

A.F.U.E. Ratings of 95% mean energy savings for you!

Our High Efficiency Furnace May Actually Pay For Itself in Energy Savings!

A home is most people's biggest investment and making sure it's comfortable in all seasons is a primary concern. A Comfort-Aire gas furnace helps provide that comfortable environment. There are several types and a wide range of capacities to meet the home's specific requirements and the homeowner's individual preferences. Not only are the furnaces quality designed and constructed, they're energy efficient, helping to save on utility bills.

All Comfort-Aire products are backed by outstanding warranties and after-sales support. Experienced technicians can help solve operation and service issues over the phone. And our web site is another resource with owner's manuals and technical documentation for installers.

The compact size of our furnaces makes them ideal for replacements; builders and architects also appreciate the installation flexibility they offer for new construction. A Comfort-Aire dealer can evaluate the home and determine which furnace (and related equipment such as central air conditioning) is best suited to specific climates and needs.

With our broad product range, Comfort-Aire has the model and accessories to suit just about any home's location and heating requirements.

Annual Fuel Utilization Efficiency (A.F.U.E. ratings) is your guide for comparing gas furnace efficiencies. The higher the number, the more efficient the furnace.

Beginning in 1992, the Federal Government required all gas furnaces to meet or exceed an A.F.U.E. (Annual Fuel Utilization Efficiency) rating of 78%. Although this was an improvement over previous furnace ratings of 65% or less, today's furnaces offer even greater efficiencies. Replacing your older gas furnace with a high efficiency 95% model can result in significant energy savings.

And the greater the number of heating load hours for your area (see chart) the greater the energy savings.

Regional Winter Heating Load Hours

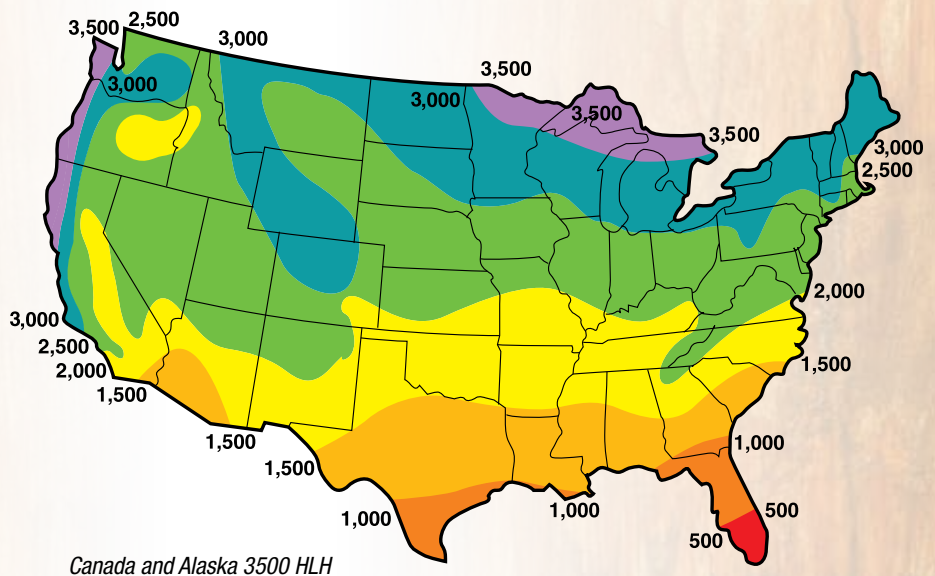

Specifications and performance data subject to change without notice.

Comfort-Aire[®]
HEAT CONTROLLER

1900 Wellworth Ave., Jackson MI 49203 • Ph. 517-787-2100 • www.comfort-aire.com

A **MARS** Company

SP 3M 6/14
Printed in USA

HC-95S-B