

## Modulating Automatic Round Damper (MARD)

### INSTALLATION INSTRUCTIONS

#### APPLICATION

The Modulating Automatic Round Damper is a round damper with a 24-Vac, floating-control type modulating motor for bypass and zone damper control. It is constructed of 22-gauge galvanized steel and has male (crimped) and female (uncrimped) ends to connect to any rigid or flexible round duct. It is available in 5, 6, 7, 8, 9, 10, 12, 14, 16, 18 inch diameter sizes. The motor timing is 90 seconds open to closed.

The MARD is used for bypass control when connected to the Static Pressure Switch (SPC). Although it can be used on any bypass application, it is recommended for systems larger than 2000 cfm. The MARD can also be used as a zone control damper connected to a zone control panel.

#### INSTALLATION

##### Before Installing this Product...

1. Read all instructions before installing this product. Failure to follow the instructions can damage the product or cause a hazardous condition.
2. Check the ratings given in the instructions and on the product to make sure the product is suitable for your application.
3. Installer must be a trained, experienced service technician.
4. Install the product in an area that is easily accessible for checkout and service.
5. After completing installation, use these instructions to check out the product operation.

##### Selecting Damper Size

1. To size the bypass damper, subtract the smallest zone cfm from the total system cfm. The remainder is the amount of air that needs to be bypassed.
2. Calculate the bypass damper size using this cfm and a friction loss of .25 in. on a duct calculator or see Table 1.
3. If used as a zone damper, size it the same diameter as the duct.

Table 1. MARD Size.

MARD Diameter	Bypass cfm <sup>a</sup>
5	120
6	200
7	300
8	400
9	600
10	750
12	1200
14	1800
16	2400
18	3200

<sup>a</sup>Use this table only to size bypass dampers; for zone damper sizing, use a duct calculator.

##### Selecting Damper Location

The damper can be installed horizontally or vertically. Orient the damper so the motor is located on the side or top of the damper, not on the bottom of the damper.

##### Mounting the Damper

1. Install a duct collar into the duct or plenum upstream of any zone dampers. It is preferable to place it as far as practical from the air handler.
2. Slide the damper onto the duct collar.
3. Secure with sheet metal screws (not provided).
4. Run duct from the other end of the damper to the return duct.



## WIRING

The ML6161B2024 motor has a 35 in.-lb, 3 VA, 24 Vac, 50/60 cycle rating. Protect the HVAC equipment from freeze-up and from tripping the high limit with a discharge air temperature sensor as follows:

- C7735A1000 on the TZ-3, EMM-3, EMM-3U, EZ-2 or EZ-4 zone control boards
- C7835A1009 on Networked Zoning
- FPC and T6031A1276 (SPBT) on older zone control boards.

Multiple dampers can be connected in parallel. See Fig. 1-4. See the SPC literature for additional connection information.

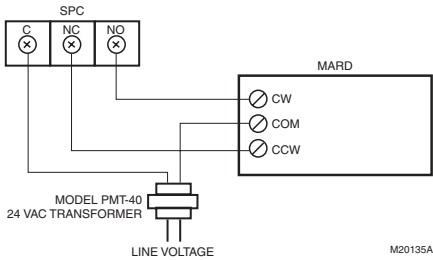

Fig. 1. Wiring SPC to control MARD damper in bypass application.

## Settings/Adjustment

See the SPC literature for configuration instructions.

## CHECKOUT

To check out the MARD:

1. With 24 Vac applied to the M1 (common) and M4 (open) terminals, observe that the motor powers the MARD to the open position.
2. With 24 Vac applied to the M1 (common) and M6 (close) terminals, observe that the motor powers the MARD to the closed position.

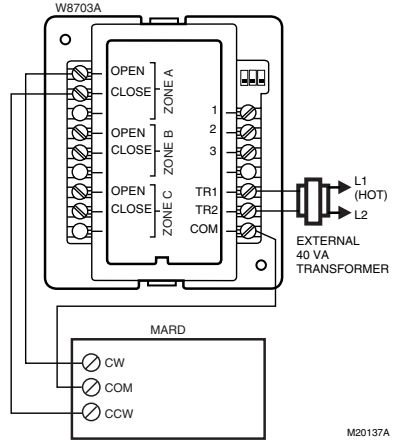

Fig. 2. Wiring MARD to W8703 Networked Zoning Damper Interface Module.

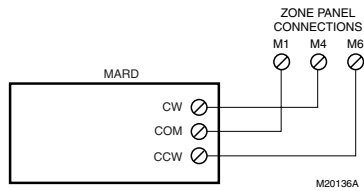

Fig. 3. Wiring MARD to a conventional zone panel.

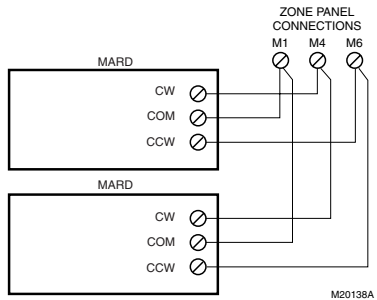

Fig. 4. Wiring two MARD in tandem to a zone panel.

**Honeywell**

### Automation and Control Solutions

Honeywell  
1985 Douglas Drive North  
Golden Valley, MN 55422

Honeywell Limited-Honeywell Limitée  
35 Dynamic Drive  
Scarborough, Ontario  
M1V 4Z9

