

Split System Submittal Data

Outdoor: **CU-2E18NBU**

MultiSystem - Outdoor

Job Name: _____

Location: _____

Engineer: _____

Submitted to: _____

Submitted by: _____

Reference: _____

Approval: _____

Date: _____

Construction: _____

Unit#: _____

Drawing#: _____

General Data	
Power (V/P/Hz)	208/230/1/60
Circuit Ampacity (A)	15
Fuse Size, Max.(A)	20
Compressor	
	DC Twin Rotary (Inverter Driven)
No. Used	1
R.L. Amps - L.R. (A)	7.0 - 13.0
Crankcase Heater (W)	N/A
Outdoor Unit	
Fan Type	Propeller
Dia & Length (in.) - No. Speeds	D18-1/8 - 1
Type Drive - No. Speeds	DC Motor
No. Poles (RPM)	8 -(570)
No. Motors (W)	1-(60)
CFM (High)	1313
F.L. Amps (A)	0.75
Coil Type	
	Aluminum Fin & Copper Pipe
Fin Type - Pipe Type	Corrugated Plate - Inner Riffled
Rows - F.P.I.	2 - 19
Face Area (sq.ft.)	6.4
Tube Size (in)	3/8"
Refrigerant	
	R410A
Lbs. - R410a	4.24
Control	Electronic Expansion Valve
Line Size (in. O.D. Discharge)	1/4" x 2 (Flare)
Line Size (in. O.D. Suction)	3/8" x 2 (Flare)
Dimensions (HxWxD)	
Indoor Unit (Uncrated) (in.)	31 5/16 x 34 15/32 x 3 3/4
Weight (lbs.)	
Net	152



SEER	18.0
Amps (A)	7.6 - 6.9
Max. Amps (A)	13.6
Power Inputs (KW)	1.45
Max. Inputs (W)	N/A
Outdoor Sound Rating (dB-A) High	48
Heating	
Total Capacity (BTU/H)	20,200 (7,200 - 24,600)
HSPF	8.8
Amps (A)	9.0 - 8.1
Max. Amps (A)	13.6
Power Inputs (KW)	1.85
Max Inputs (W)	N/A
Outdoor Sound Rating (dB-A) High	49

Performance Data @ ARI Standard Conditions (230/208V)	
Cooling	
Total Capacity (BTU/H)	16700 (7200 - 20000)
Sensible Capacity (BTU/H)	16,020
Latent Capacity (BTU/H)	1980

Operating Range	Indoor Air Intake Temp	Outdoor Air Intake Temp
Cooling (Max)	89.6F DB/73.4F WB	109.4F DB
Cooling (Min)	60.8 DB/51.8F WB	60.8F DB
Cooling (Max)	86F DB	75.2F DB
Cooling (Min)		5F DB

Outdoor Dimensions

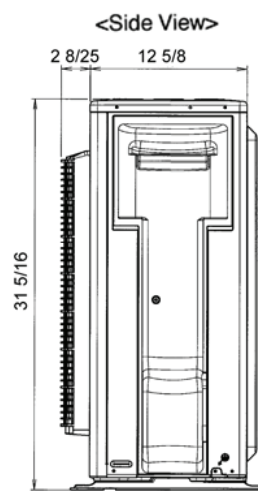
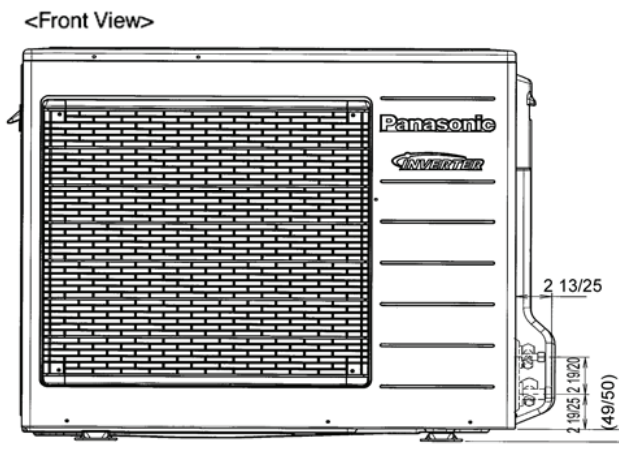
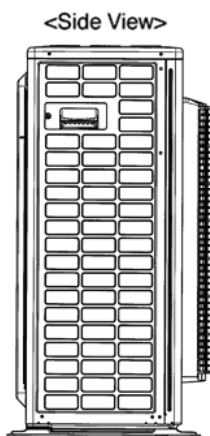
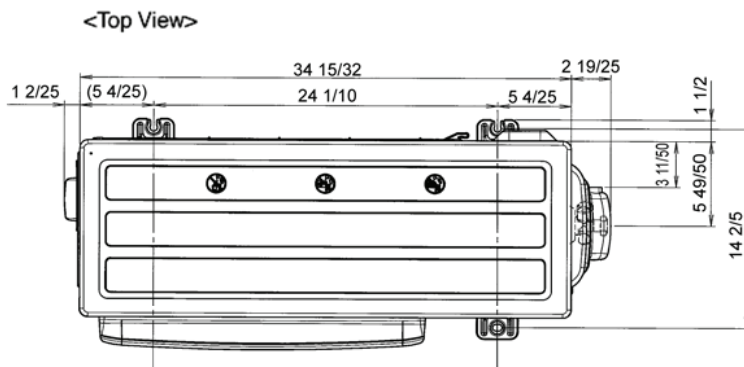
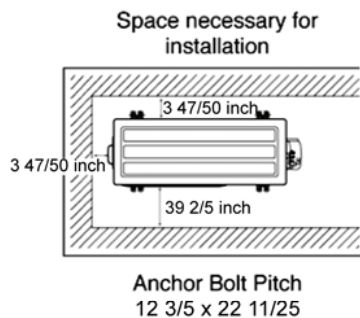

Unit:inch

Panasonic

Panasonic North America
Air Conditioning Division
1690 Roberts Blvd., NW, Suite 110
Kennesaw, GA 30144
<http://www.panasonic.com/aircon>