

INSTALLATION INSTRUCTIONS

AIR-COOLED CONDENSING UNITS

(-)AKB (50 & 60 Hz MODELS), (-)AND & (-)APC MODEL SERIES



RECOGNIZE THIS SYMBOL AS AN INDICATION OF IMPORTANT SAFETY INFORMATION!

▲ WARNING

THESE INSTRUCTIONS ARE INTENDED AS AN AID TO QUALIFIED, LICENSED SERVICE PERSONNEL FOR PROPER INSTALLATION, ADJUSTMENT AND OPERATION OF THIS UNIT. READ THESE INSTRUCTIONS THOROUGHLY BEFORE ATTEMPTING INSTALLATION OR OPERATION. FAILURE TO FOLLOW THESE INSTRUCTIONS MAY RESULT IN IMPROPER INSTALLATION, ADJUSTMENT, SERVICE OR MAINTENANCE POSSIBLY RESULTING IN FIRE, ELECTRICAL SHOCK, PROPERTY DAMAGE, PERSONAL INJURY OR DEATH.



Accredited by the RvA



ISO 9001:2000

Certificate Number: 30164

DO NOT DESTROY THIS MANUAL

PLEASE READ CAREFULLY AND KEEP IN A SAFE PLACE FOR FUTURE REFERENCE BY A SERVICEMAN

TABLE OF CONTENTS

Checking Product Received	2
Dimensions	3
Electrical & Physical Data	4 - 5
General	6
Application	6
Locating Unit	6
Unit Mounting	8
Factory-Preferred Tie-Down Method	8
Refrigerant Connections	8
Replacement Units	8
Evaporator Coil	9
Interconnecting Tubing	9-11
Flowcheck Piston	12
Evacuation Procedure	14
Start-Up and Performance	15
Checking Airflow	15
Checking Refrigerant Charge	16
Charging by Superheat	16
Charging by Liquid Pressure	16
Charging by Weight	16
Final Leak Testing	17
Electrical Wiring	17
Field Installed Accessories	18
Service	19
Trouble Shooting	20-22
Trouble Shooting Chart	23
Wiring Diagrams	24-27

CHECKING PRODUCT RECEIVED

Upon receiving unit, inspect it for any shipping damage. Claims for damage, either apparent or concealed, should be filed immediately with the shipping company. Check condensing unit model number, electrical characteristics and accessories to determine if they are correct and match the original order from the local distributor. Check system components (evaporator coil, condensing unit, evaporator blower, etc.) to make sure they are properly matched.

FIGURE 1
DIMENSIONS AND INSTALLATION CLEARANCES

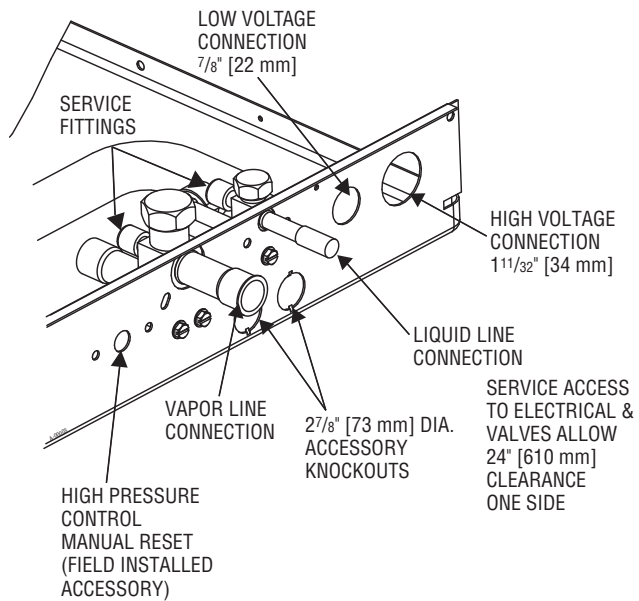
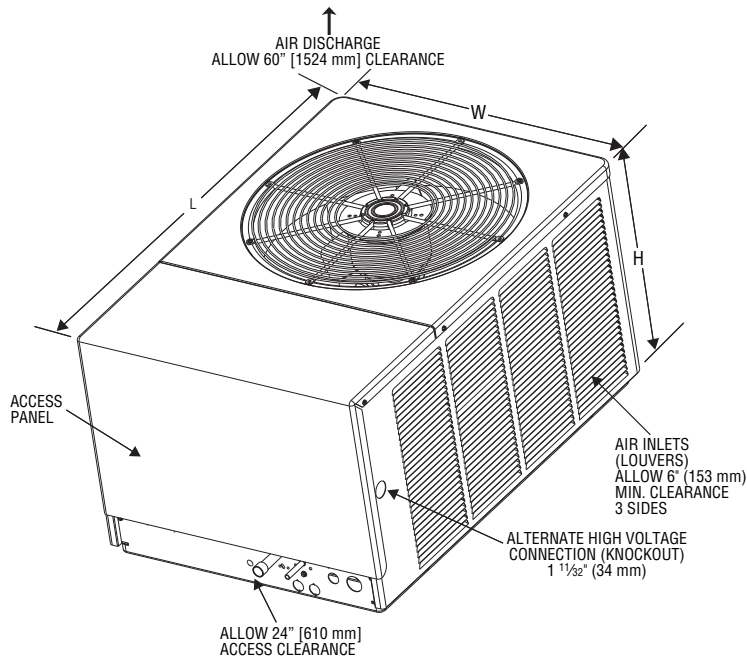

UNIT MODEL NUMBER EXPLANATION

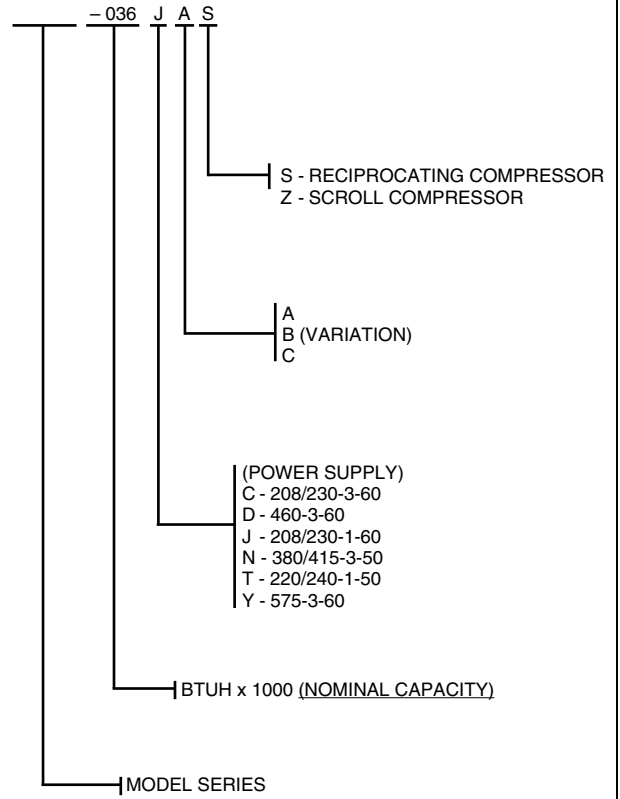

BASE PAN

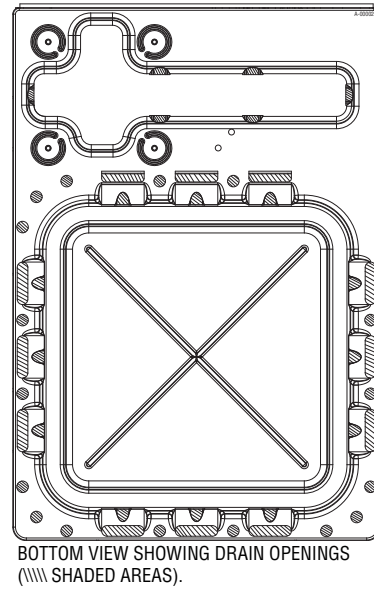

DIMENSIONAL DATA

CONDENSING UNIT MODEL	(-)AKB	018, 024	030	036, 042		048, 060		
	(-)JAND		018	024	030		036, 042	048, 060
	(-)APC					024, 030, 042		036, 048, 060
HEIGHT "H" (INCHES) [MM]		16 13/16 [427]	18 13/16 [18.8]	18 13/16 [18.8]	18 13/16 [18.8]	22 13/16 [579.4]	24 13/16 [630.2]	32 13/16 [833.4]
LENGTH "L" (INCHES) [MM]		33 13/16 [858.8]	33 13/16 [858.8]	38 13/16 [985.8]	42 13/16 [42.8]	42 11/16 [42.7]	42 11/16 [42.7]	42 11/16 [42.7]
WIDTH "W" (INCHES) [MM]		23 3/8 [593.7]	23 3/8 [593.7]	27 1/4 [692.2]	31 1/8 [790.6]	31 1/8 [790.6]	31 1/8 [790.6]	31 1/8 [790.6]

TABLE 1A

(-)AKB ELECTRICAL AND PHYSICAL DATA (60 Hz MODELS)

Model Number RAKB-	Phase Frequency (Hz) Voltage (Volts)	Electrical						Outdoor Coil			Refrig. Per Circuit Oz. [g]	Weight	
		Compressor		Fan Motor Full Load Amperes (FLA)	Minimum Circuit Ampacity Amperes	Fuse or HACR Circuit Breaker		Face Area Sq. Ft. [m ²]	No. Rows	CFM [L/s]		Net Lbs. [kg]	Shipping Lbs. [kg]
		Rated Load Amperes (RLA)	Locked Rotor Amperes (LRA)			Minimum Amperes	Maximum Amperes						
036CAZ	3-60-208/230	10.3/10.3	77	1.3	15/15	20/20	20/20	11 [1.02]	1	2700 [1274]	79 [2240]	170 [77.1]	180 [81.6]
036DAZ	3-60-460	5.1	39	0.6	8	15	15	11 [1.02]	1	2700 [1274]	79 [2240]	170 [77.1]	180 [81.6]
042CAZ	3-60-208/230	12.4/12.4	88	1.3	17/17	20/20	25/25	11 [1.02]	1	2700 [1274]	79 [2240]	180 [81.6]	190 [86.2]
042DAZ	3-60-460	6.4	44	0.6	9	15	15	11 [1.02]	1	2700 [1274]	79 [2240]	180 [81.6]	190 [86.2]
048CAZ	3-60-208/230	12.8/12.8	91	1.5	18/18	25/25	30/30	15.82 [1.47]	1	3500 [1652]	103 [2920]	200 [90.7]	210 [95.3]
048DAZ	3-60-460	6.4	46	1	10	15	15	15.82 [1.47]	1	3500 [1652]	103 [2920]	200 [90.7]	210 [95.3]
048YAS	3-60-575	5.1	36	0.7	8	15/15	15	15.82 [1.47]	1	3500 [1652]	113 [3204]	200 [90.7]	210 [95.3]
060CAZ	3-60-208/230	18.6/18.6	128	1.5	25/25	30/30	40/40	15.82 [1.47]	1	3500 [1652]	112 [3175]	230 [104.3]	240 [108.9]
060DAZ	3-60-460	9	63	1	13	15	20	15.82 [1.47]	1	3500 [1652]	112 [3175]	230 [104.3]	240 [108.9]
060YAS	3-60-575	6	44	0.7	9	15	15	15.82 [1.47]	1	3500 [1652]	112 [3175]	230 [104.3]	240 [108.9]
018JAZ	1-60-208/230	9.6/9.6	47	0.9	13/13	20/20	20/20	5.97 [0.55]	1	1850 [873]	49 [1389]	130 [59]	140 [63.5]
024JAZ	1-60-208/230	11.9/11.9	59	0.9	16/16	20/20	25/25	5.97 [0.55]	1	1850 [873]	56 [1588]	135 [61.2]	145 [65.8]
030JAZ	1-60-208/230	14.1/14.1	69	0.9	19/19	25/25	30/30	9.07 [0.84]	1	1860 [878]	66 [1871]	145 [65.8]	155 [70.3]
036CAZ	3-60-208/230	10.3/10.3	77	1.3	15/15	20/20	20/20	11 [1.02]	1	2700 [1274]	79 [2240]	170 [77.1]	180 [81.6]
036DAZ	3-60-460	5.1	39	0.6	8	15	15	11 [1.02]	1	2700 [1274]	79 [2240]	170 [77.1]	180 [81.6]
036JAZ	1-60-208/230	16.5/16.5	95	1.3	22/22	30/30	35/35	11 [1.02]	1	2700 [1274]	79 [2240]	170 [77.1]	180 [81.6]
042CAS	3-60-208/230	11.6/11.6	73.4	1.3	16/16	20/20	25/25	11 [1.02]	1	2700 [1274]	79 [2240]	180 [81.6]	190 [86.2]
042CAZ	3-60-208/230	12.4/12.4	88	1.3	17/17	20/20	25/25	11 [1.02]	1	2700 [1274]	79 [2240]	180 [81.6]	190 [86.2]
042DAS	3-60-460	5.6	37	0.6	8	15	15	11 [1.02]	1	2700 [1274]	79 [2240]	180 [81.6]	190 [86.2]
042DAZ	3-60-460	6.4	44	0.6	9	15	15	11 [1.02]	1	2700 [1274]	79 [2240]	180 [81.6]	190 [86.2]
042JAZ	1-60-208/230	18.3/18.3	109	1.3	25/25	-	40/40	11 [1.02]	1	2700 [1274]	79 [2240]	180 [81.6]	190 [86.2]
048CAS	3-60-208/230	12.8/12.8	78	1.5	18/18	25/25	30/30	15.82 [1.47]	1	3500 [1652]	113 [3204]	200 [90.7]	210 [95.3]
048CAZ	3-60-208/230	12.8/12.8	91	1.5	18/18	25/25	30/30	15.82 [1.47]	1	3500 [1652]	103 [2920]	200 [90.7]	210 [95.3]
048DAS	3-60-460	6.9	41	1	10	15	15	15.82 [1.47]	1	3500 [1652]	113 [3204]	200 [90.7]	210 [95.3]
048DAZ	3-60-460	6.4	46	1	10	15	15	15.82 [1.47]	1	3500 [1652]	103 [2920]	200 [90.7]	210 [95.3]
048JAZ	1-60-208/230	21.8/21.8	131	1.5	29/29	35/35	50/50	15.82 [1.47]	1	3500 [1652]	103 [2920]	200 [90.7]	210 [95.3]
048YAS	3-60-575	5.1	36	0.7	8	15	15	15.82 [1.47]	1	3500 [1652]	113 [3204]	200 [90.7]	210 [95.3]
060CAS	3-60-208/230	16.7/16.7	110	1.5	23/23	30/30	35/35	15.82 [1.47]	1	3500 [1652]	112 [3175]	230 [104.3]	240 [108.9]
060CAZ	3-60-208/230	18.6/18.6	128	1.5	25/25	30/30	40/40	15.82 [1.47]	1	3500 [1652]	112 [3175]	230 [104.3]	240 [108.9]
060DAS	3-60-460	8.6	55	1	12	15	20	15.82 [1.47]	1	3500 [1652]	112 [3175]	230 [104.3]	240 [108.9]
060DAZ	3-60-460	9	63	1	13	15	20	15.82 [1.47]	1	3500 [1652]	112 [3175]	230 [104.3]	240 [108.9]
060JAZ	1-60-208/230	28.8/28.8	175	1.5	38/38	45/45	60/60	15.82 [1.47]	1	3500 [1652]	112 [3175]	230 [104.3]	240 [108.9]
060YAS	3-60-575	6	44	0.7	9	15	15	15.82 [1.47]	1	3500 [1652]	112 [3175]	230 [104.3]	240 [108.9]

NOTE: Factory refrigerant charge includes refrigerant for 25 feet of standard line set.

TABLE 1B

SAKB ELECTRICAL AND PHYSICAL DATA (50 Hz MODELS)

Model Number SAKB-	Phase Frequency (Hz) Voltage (Volts)	Electrical						Outdoor Coil			Refrig. Per Circuit Oz. [g]	Weight	
		Compressor		Fan Motor Full Load Amperes (FLA)	Minimum Circuit Ampacity Amperes	Fuse or HACR Circuit Breaker		Face Area Sq. Ft. [m ²]	No. Rows	CFM [L/s]		Net Lbs. [kg]	Shipping Lbs. [kg]
		Rated Load Amperes (RLA)	Locked Rotor Amperes (LRA)			Minimum Amperes	Maximum Amperes						
018TAS	1-50-220/240	9/9	51	0.9	13/13	15/15	20/20	5.97 [0.55]	1	1850 [873]	42 [1191]	130 [59]	140 [63.5]
024TAS	1-50-220/240	9/9	51	0.9	13/13	15/15	20/20	5.97 [0.55]	1	1850 [873]	46 [1304]	135 [61.2]	145 [65.8]
030TAS	1-50-220/240	11.2/11.2	65	0.9	15/15	20/20	25/25	9.07 [0.84]	1	1860 [878]	62 [1758]	145 [65.8]	155 [70.3]
036NAS	3-50-380/415	5.1/5.1	33	0.6	7/7	15/15	15/15	11 [1.02]	1	2700 [1274]	68 [1928]	170 [77.1]	180 [81.6]
036TAS	1-50-220/240	13.7/13.7	81	1.3	19/19	25/25	30/30	11 [1.02]	1	2700 [1274]	68 [1928]	170 [77.1]	180 [81.6]
042NAS	3-50-380/415	6.2/6.2	37	0.6	9/9	15/15	15/15	11 [1.02]	1	2700 [1274]	72 [2041]	180 [81.6]	190 [86.2]
042TAS	1-50-220/240	16.5/16.5	94	1.3	22/22	30/30	35/35	11 [1.02]	1	2700 [1274]	72 [2041]	180 [81.6]	190 [86.2]
048NAS	3-50-380/415	7/7	46	1	10/10	15/15	15/15	15.82 [1.47]	1	3500 [1652]	103 [2920]	200 [90.7]	210 [95.3]
048TAS	1-50-220/240	18.3/18.3	102	1.5	25/25	30/30	40/40	15.82 [1.47]	1	3500 [1652]	103 [2920]	200 [90.7]	210 [95.3]
060NAS	3-50-380/415	8.6/8.6	64	1	11/11	15/15	15/15	15.82 [1.47]	1	3500 [1652]	102 [2892]	230 [104.3]	240 [108.9]
065NAS	3-50-380/415	9/9	74	1	13/13	15/15	20/20	15.82 [1.47]	1	3500 [1652]	105 [2977]	230 [104.3]	245 [111.1]

NOTE: Factory refrigerant charge includes refrigerant for 25 feet of standard line set.

TABLE 2

(-)AND ELECTRICAL AND PHYSICAL DATA

Model Number (-)AND-	ELECTRICAL							PHYSICAL						
	Phase Frequency (Hz) Voltage (Volts)	Compressor		Fan Motor Full Load Amperes (FLA)	Minimum Circuit Ampacity Amperes	Fuse or HACR Circuit Breaker		Outdoor Coil			R22 Oz. [g]	Weight		
		Rated Load Amperes (RLA)	Locked Rotor Amperes (LRA)			Minimum Amperes	Maximum Amperes	Face Area Sq. Ft. [m²]	No. Rows	CFM [L/s]		Net Lbs. [kg]	Shipping Lbs. [kg]	
018JAZ	1-60-208/230	7.7/7.7	40.3	0.6	11/11	15/15	15/15	9.07 [0.84]	1	1640 [774]	68 [1928]	135 [61.2]	145 [65.8]	
024JAZ	1-60-208/230	10.4/10.4	54	0.6	14/14	20/20	20/20	11 [1.02]	1	1900 [897]	76 [2155]	145 [65.8]	155 [70.3]	
030JAZ	1-60-208/230	14.1/14.1	72.5	0.8	19/19	25/25	30/30	12.94 [1.2]	1	2520 [1189]	88 [2495]	160 [72.6]	170 [77.1]	
036CAZ	3-60-208/230	9.6/9.6	88	1.2	14/14	20/20	20/20	17.26 [1.6]	1	3290 [1553]	116 [3289]	180 [81.6]	190 [86.2]	
036DAZ	3-60-460	5.8	38	0.6	8	15	15	17.26 [1.6]	1	3290 [1553]	116 [3289]	180 [81.6]	190 [86.2]	
036JAZ	1-60-208/230	14.4/14.4	77	1.2	20/20	25/25	30/30	17.26 [1.6]	1	3290 [1553]	116 [3289]	180 [81.6]	190 [86.2]	
042CAZ	3-60-208/230	12.2/12.2	88	1.2	17/17	20/20	25/25	17.26 [1.6]	1	3290 [1553]	136 [3856]	195 [88.5]	205 [93]	
042DAZ	3-60-460	5.8	44	0.6	8	15	15	17.26 [1.6]	1	3290 [1553]	136 [3856]	195 [88.5]	205 [93]	
042JAZ	1-60-208/230	19.2/19.2	105	1.2	26/26	30/30	40/40	17.26 [1.6]	1	3290 [1553]	136 [3856]	195 [88.5]	205 [93]	
048CAZ	3-60-208/230	12.2/12.2	83.1	1.2	17/17	20/20	25/25	23.01 [2.14]	1	3500 [1652]	146 [4139]	225 [102.1]	235 [106.6]	
048DAZ	3-60-460	6.1	41	0.6	9	15	15	23.01 [2.14]	1	3500 [1652]	146 [4139]	225 [102.1]	235 [106.6]	
048JAZ	1-60-208/230	20.2/20.2	137	1.2	27/27	35/35	45/45	23.01 [2.14]	1	3500 [1652]	146 [4139]	225 [102.1]	235 [106.6]	
048YAZ	3-60-575	4.8	33	0.5	6	15	15	23.01 [2.14]	1	3500 [1652]	146 [4139]	225 [102.1]	235 [106.6]	
060CAZ	3-60-208/230	15.4/15.4	110	1.2	21/21	25/25	35/35	23.01 [2.14]	1	3500 [1652]	176 [4990]	230 [104.3]	240 [108.9]	
060DAZ	3-60-460	7.1	52	0.6	10	15	15	23.01 [2.14]	1	3500 [1652]	176 [4990]	230 [104.3]	240 [108.9]	
060JAZ	1-60-208/230	25.3/25.3	150	1.2	33/33	40/40	50/50	23.01 [2.14]	1	3500 [1652]	176 [4990]	230 [104.3]	240 [108.9]	
060YAZ	3-60-575	5.3	36.1	0.5	8	15	15	23.01 [2.14]	1	3500 [1652]	176 [4990]	230 [104.3]	240 [108.9]	

NOTE: Factory refrigerant charge includes refrigerant for 15 feet of standard line set.

TABLE 3

(-)APC ELECTRICAL AND PHYSICAL DATA

Model Number (-)APC-	ELECTRICAL							PHYSICAL						
	Phase Frequency (Hz) Voltage (Volts)	Compressor		Fan Motor Full Load Amperes (FLA)	Minimum Circuit Ampacity Amperes	Fuse or HACR Circuit Breaker		Outdoor Coil			R22 Oz. [g]	Weight		
		Rated Load Amperes (RAL)	Locked Rotor Amperes (LRA)			Minimum Amperes	Maximum Amperes	Face Area Sq. Ft. [m²]	No. Rows	CFM [L/s]		Net Lbs. [kg]	Shipping Lbs. [kg]	
024JA	1-60-208/230	10.9/10.9	56	0.8	15/15	20/20	25/25	15.8 [1.47]	1	2285 [1078]	114 [3232]	190 [86.2]	200 [90.7]	
030JA	1-60-208/230	12.2/12.2	72	0.8	18/18	25/25	30/30	15.8 [1.47]	1	2285 [1078]	120 [3402]	200 [90.7]	210 [95.3]	
036JA	1-60-208/230	13.5/13.5	88	1.0	22/22	25/25	35/35	23.0 [2.14]	1	3900 [1841]	160 [4536]	230 [104.3]	240 [108.9]	
042JA	1-60-208/230	16.5/16.5	104	1.0	24/24	30/30	40/40	15.4 [1.43]	2	3190 [1506]	168 [4763]	235 [106.6]	245 [111.1]	
048JA	1-60-208/230	17.9/17.9	109	1.5	25/25	30/30	40/40	22.4 [2.08]	2	3500 [1652]	288 [8165]	300 [136.1]	310 [140.6]	
060JA	1-60-208/230	19.9/19.9	137	1.5	27/27	35/35	45/45	22.4 [2.08]	2	3500 [1652]	296 [8392]	305 [138.3]	315 [142.9]	

NOTE: Factory refrigerant charge includes refrigerant for 25 feet of standard line set.

WARNING

THE MANUFACTURER'S WARRANTY DOES NOT COVER ANY DAMAGE OR DEFECT TO THE AIR CONDITIONER CAUSED BY THE ATTACHMENT OR USE OF ANY COMPONENTS, ACCESSORIES OR DEVICES (OTHER THAN THOSE AUTHORIZED BY THE MANUFACTURER) INTO, ONTO OR IN CONJUNCTION WITH THE AIR CONDITIONER. YOU SHOULD BE AWARE THAT THE USE OF UNAUTHORIZED COMPONENTS, ACCESSORIES OR DEVICES MAY ADVERSELY AFFECT THE OPERATION OF THE AIR CONDITIONER AND MAY ALSO ENDANGER LIFE AND PROPERTY. THE MANUFACTURER DISCLAIMS ANY RESPONSIBILITY FOR SUCH LOSS OR INJURY RESULTING FROM THE USE OF SUCH UNAUTHORIZED COMPONENTS, ACCESSORIES OR DEVICES.

MATCH ALL COMPONENTS:

- OUTDOOR UNIT
- INDOOR COIL/METERING DEVICE
- INDOOR AIR HANDLER/FURNACE
- REFRIGERANT LINES

GENERAL

The information contained in this manual has been prepared to assist in the proper installation, operation and maintenance of the air conditioning system. Improper installation, or installation not made in accordance with these instructions, can result in unsatisfactory operation and/or dangerous conditions, and can cause the related warranty not to apply.

Read this manual and any instructions packaged with separate equipment required to make up the system prior to installation. Retain this manual for future reference.

To achieve optimum efficiency and capacity, the indoor cooling coils listed in the condensing unit specification sheet should be used.

IMPORTANT: We recommend replacement of any HVAC equipment that has been subjected to flooding in order to avoid any risk of injury or harm.

IMPORTANT: Use all available safety precautions during the installation and servicing of any HVAC equipment.

APPLICATION

Before installing any air conditioning equipment, a duct analysis of the structure and a heat gain calculation must be made. A heat gain calculation begins by measuring all external surfaces and openings that gain heat from the surrounding air and quantifying that heat gain. A heat gain calculation also calculates the extra heat load caused by sunlight and by humidity removal.

There are several factors that the installers must consider:

- Outdoor unit location
- System refrigerant charge
- Indoor unit blower speed
- System air balancing
- Proper equipment evacuation
- Indoor unit airflow
- Supply and return air duct design and sizing
- Diffuser and return air grille location and sizing

LOCATING UNIT

CONDENSER LOCATION

Consult local and national building codes and ordinances for special installation requirements. Following location information will provide longer life and simplified servicing of the outdoor condenser.

NOTE: These units must be installed outdoors. No ductwork can be attached, or other modifications made, to the discharge grille. Modifications will affect performance or operation.

OPERATIONAL ISSUES

- **IMPORTANT:** Locate the condenser in a manner that will not prevent, impair or compromise the performance of other equipment horizontally installed in proximity to the unit. Maintain all required minimum distances to gas and electric meters, dryer vents, exhaust and inlet openings. In the absence of National Codes, or manufacturers' recommendations, local code recommendations and requirements will take precedence.
- Refrigerant piping and wiring should be properly sized and kept as short as possible to avoid capacity losses and increased operating costs.
- Locate the condenser where water run off will not create a problem with the equipment. Position the unit away from the drip edge of the roof whenever possible. Units are weatherized, but can be affected by water pouring into the unit from the junction of rooflines without protective guttering.

FOR CONDENSERS WITH SPACE LIMITATIONS

In the event that a space limitation exists, we will permit the following clearances:

Single Unit Applications: Clearances below 6 inches [152.4 mm] will reduce unit capacity and efficiency. Do not reduce the 60-inch [1524 mm] discharge, or the 24-inch [609.6 mm] service clearances.

Multiple Unit Applications: When multiple condenser grille sides are aligned, a 6-inch per unit clearance is recommended, for a total of 12" [304.8 mm] between two units. Two combined clearances below 12 inches [304.8 mm] will reduce capacity and efficiency. Do not reduce the 60-inch [1524 mm] discharge, or 24-inch [609.6 mm] service, clearances.

CUSTOMER SATISFACTION ISSUES

- The condenser should be located away from the living, sleeping and recreational spaces of the owner and those spaces on adjoining property.
- To prevent noise transmission, the mounting pad for the outdoor unit should not be connected to the structure, and should be located sufficient distance above grade to prevent ground water from entering the unit.

CORROSIVE ENVIRONMENT

The metal parts of this unit may be subject to rust or deterioration if exposed to a corrosive environment. This oxidation could shorten the equipment's useful life. Corrosive elements include, but are not limited to, salt spray, fog or mist in seacoast areas, sulphur or chlorine from lawn watering systems, and various chemical contaminants from industries such as paper mills and petroleum refineries.

If the unit is to be installed in an area where contaminants are likely to be a problem, special attention should be given to the equipment location and exposure.

- Avoid having lawn sprinkler heads spray directly on the unit cabinet.
- In coastal areas, locate the unit on the side of the building away from the waterfront.
- Shielding provided by a fence or shrubs may give some protection, but cannot violate minimum airflow and service access clearances.
- Elevating the unit off its slab or base enough to allow air circulation will help avoid holding water against the basepan.

WARNING

DISCONNECT ALL POWER TO UNIT BEFORE STARTING MAINTENANCE. FAILURE TO DO SO CAN CAUSE ELECTRICAL SHOCK RESULTING IN SEVERE PERSONAL INJURY OR DEATH.

Regular maintenance will reduce the build-up of contaminants and help to protect the unit's finish.

- Frequent washing of the cabinet, fan blade and coil with fresh water will remove most of the salt or other contaminants that build up on the unit.
- Regular cleaning and waxing of the cabinet with an automobile polish will provide some protection.
- A liquid cleaner may be used several times a year to remove matter that will not wash off with water.

Several different types of protective coatings are offered in some areas. These coatings may provide some benefit, but the effectiveness of such coating materials cannot be verified by the equipment manufacturer.

UNIT MOUNTING

If elevating the condensing unit, either on a flat roof or on a slab, observe the following guidelines.

- The base pan provided elevates the condenser coil 3/4" [19 mm] above the base pad.
- If elevating a unit on a flat roof, use 4" [101.6 mm] x 4" [101.6 mm] (or equivalent) stringers positioned to distribute unit weight evenly and prevent noise and vibration.

NOTE: Do not block drain openings shown in Figure 1.

FACTORY-PREFERRED TIE-DOWN METHOD FOR CONDENSING UNITS

IMPORTANT: These instructions are intended as a guide to securing equipment for wind-load ratings of "120 MPH sustained wind load" and "3-second, 150 MPH gust." While this procedure is not mandatory, the Manufacturer does recommend that equipment be properly secured in areas where high wind damage may occur.

STEP 1: Before installing, clear pad of any dirt or debris.

IMPORTANT: The pad must be constructed of industry-approved materials, and must be thick enough to accommodate the concrete fastener.

STEP 2: Center base pan on pad, ensuring it is level.

STEP 3: Using basepad as a guide, mark spots on concrete where 4 holes will be drilled (see Figure 2).

TABLE 4
DIMENSIONS OF BASE PAN

MODEL NUMBER	L	W	A	B	C	D
AKB-018/024/030						
AND-018/024/030	32.625 [828.7]	22.063 [560.4]	14 [355.6]	29 [736.6]	3.5 [88.9]	18.5 [469.9]
AKB-036/042, AND-024	37.625 [955.7]	25.938 [658.8]	15 [381]	34 [863.6]	3.5 [88.9]	22.5 [571.5]
AKB-048/060, APC-024/030/036/042/049/061, AND-030/036/042/048/060	41.5 [1054.1]	29.813 [757.3]	15 [381]	38 [965.2]	3.5 [88.9]	26.5 [673.1]

STEP 4: Drill four pilot holes in pad, ensuring that the hole is at least 1/4" [6.4 g] deeper than the concrete screw being used.

STEP 5: Center basepan over pre-drilled holes and insert concrete screws.

STEP 6: Tighten concrete screws.

NOTE: Do not over-tighten the concrete screws. Doing so can weaken the integrity of the concrete screw and cause it to break.

STEP 7: Finish unit assembly per unit's installation instructions.

REFRIGERANT CONNECTIONS

All units are factory charged with Refrigerant 22. All models are supplied with service valves. Keep tube ends sealed until connection is to be made to prevent system contamination.

REPLACEMENT UNITS

To prevent failure of a new condensing unit, the existing evaporator tubing system must be correctly sized and cleaned or replaced. Care must be exercised that the expansion device is not plugged. Test the oil for acid. If positive, a suction line filter drier is mandatory. For new and replacement units, a liquid line filter drier should be installed and refrigerant tubing should be properly sized.

FIGURE 2
SCREW LOCATIONS

(4) 1/4" CONCRETE SCREWS SNUG TO BASE PAN. LENGTH TO PENETRATE CONCRETE 1.5" MINIMUM. SCREWS HAVE TO BE PLACED ON THE BASE PAN AS SHOWN

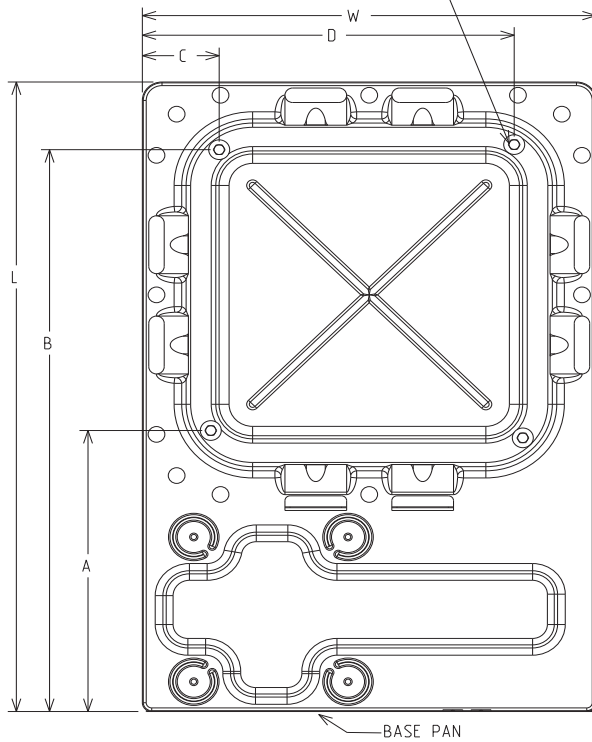

EVAPORATOR COIL

REFER TO EVAPORATOR COIL MANUFACTURER'S INSTALLATION INSTRUCTIONS.

IMPORTANT: The manufacturer is not responsible for the performance and operation of a mismatched system, or for a match listed with another manufacturer's coil.

LOCATION

Do not install the indoor evaporator coil in the return duct system of a gas or oil furnace. Provide a service inlet to the coil for inspection and cleaning. Keep the coil pitched toward the drain connection.

⚠ CAUTION

When coil is installed over a finished ceiling and/or living area, it is recommended that a secondary sheet metal condensate pan be constructed and installed under entire unit. Failure to do so can result in property damage.

INTERCONNECTING TUBING

VAPOR AND LIQUID LINES

Keep all lines sealed until connection is made.

Make connections at the indoor coil first.

Refer to Line Size Information in Table 6 for correct size and multipliers to be used to determine capacity for various vapor line diameters and lengths of run. The losses due to the lines being exposed to outdoor conditions are not included.

The factory refrigeration charge in the outdoor unit is sufficient for 15 feet [(-)AND only] or 25 feet [(-)AKB (3 phase models only), and (-)APC] of interconnecting lines. The factory refrigeration charge in the outdoor unit is sufficient for the unit and 15 feet of standard size interconnecting liquid and vapor lines. For different lengths, adjust the charge as indicated below.

- 1/4" [6.35 mm] ± .3 oz. [8.5 g] per foot [meter]
5/16" [1.6 mm] ± .4 oz. [11.3 g] per foot [meter]
3/8" [9.5] ± .6 [17 g] oz. per foot [meter]
1/2" [12.74] ± 1.2 [34 g] oz. per foot [meter]

MAXIMUM LENGTH OF LINES

The maximum length of interconnecting line is 150 feet. Always use the shortest length possible with a minimum number of bends. Additional compressor oil is not required for any length up to 150 feet.

NOTE: Excessively long refrigerant lines cause loss of equipment capacity.

OUTDOOR UNIT INSTALLED ABOVE INDOOR COIL

Keep the vertical separation between coils to a minimum. However, the vertical distance can be as great as 120 feet with the condensing unit ABOVE the indoor coil. Use the following guidelines when installing the unit:

1. DO NOT exceed 120 feet maximum vertical separation.
2. DO NOT change the flow check piston sizes if the vertical separation does not exceed the values in Table 7.
3. Flow Check Piston Coil:
 - a. The vertical separation can be greater than the value in Table 6, but no more than 120 feet.
 - b. If the separation height exceeds the Table value, reduce the indoor coil flow check piston by two sizes plus one size for additional 10 feet beyond the Table value.
4. Expansion Valve Coil:
 - a. The vertical separation can be greater than the value in Table 6, but no more than 120 feet.
 - b. No changes are required for expansion valve coils.
5. Capillary Tube Coil:

DO NOT exceed the Table values for vertical separation for capillary tube coils.
6. Always use the smallest liquid line size permitted to minimize the system charge.
7. Table 6 may be used for sizing horizontal runs.

OUTDOOR UNIT BELOW INDOOR COIL

Keep the vertical separation to a minimum. Use the following guidelines when installing the unit:

1. DO NOT exceed the vertical separations as indicated on Table 6.
2. Always use the smallest liquid line size permitted to minimize system charge.
3. No changes are required for either flow check piston coils or expansions coils.
4. Table 6 may be used for sizing horizontal runs.

TUBING INSTALLATION

Observe the following when installing correctly sized type "L" refrigerant tubing between the condensing unit and evaporator coil:

- If a portion of the liquid line passes through a hot area where liquid refrigerant can be heated to form vapor, insulating the liquid line is required.
- Use clean, dehydrated, sealed refrigeration grade tubing.
- Always keep tubing sealed until tubing is in place and connections are to be made.
- Blow out the liquid and vapor lines with dry nitrogen before connecting to the outdoor unit and indoor coil. For an air conditioning system, any debris in the line set could end up plugging the expansion device.
- As an added precaution, a high quality filter drier is recommended to be installed in the liquid line, if not factory installed.

- If tubing has been cut, make sure ends are deburred while holding in a position to prevent chips from falling into tubing. Burrs such as those caused by tubing cutters can affect performance dramatically, particularly on small liquid line sizes.
- For best operation, keep tubing run as short as possible with a minimum number of elbows or bends.
- Locations where the tubing will be exposed to mechanical damage should be avoided. If it is necessary to use such locations, the copper tubing should be housed to prevent damage.
- If tubing is to be run underground, it must be run in a sealed watertight chase.
- Use care in routing tubing and do not kink or twist. Use a good tubing bender on the vapor line to prevent kinking.
- The vapor line must be insulated to prevent dripping (sweating) and prevent performance losses. Armaflex and Rubatex are satisfactory insulations for this purpose. Use 1/2" [12.7 mm] minimum insulation thickness, additional insulation may be required for long runs.
- Check Table 5 for the correct vapor line size. Check Table 6 for the correct liquid line size.

TUBING CONNECTIONS

Indoor evaporator coils have only a holding charge of dry nitrogen. Keep all tube ends sealed until connections are to be made.

- Use type "L" copper refrigeration tubing. Braze the connections with accepted industry practices.
- Be certain both refrigerant service valves at the outdoor unit are closed.
- Clean the fittings before brazing.
- Remove the cap and schrader core from service port to protect seals from heat damage.
- Use an appropriate heatsink material around the copper stub and the service valves before applying heat.
- **IMPORTANT:** Do not braze any fitting with the TEV sensing bulb attached.
- Braze the tubing between the outdoor unit and indoor coil. Flow dry nitrogen into a service port and through the tubing while brazing.
- After brazing – use an appropriate heatsink material to cool the joint and remove any flux residue.

LEAK TESTING

- Pressurize line set and coil through service fittings with dry nitrogen to 150 psig maximum. Leak test all joints using liquid detergent. If a leak is found, repair and repeat leak test procedures.

WARNING

DO NOT USE OXYGEN TO PURGE LINES OR PRESSURIZE SYSTEM FOR LEAK TEST. OXYGEN REACTS VIOLENTLY WITH OIL, WHICH CAN CAUSE AN EXPLOSION RESULTING IN SEVERE PERSONAL INJURY OR DEATH.

TABLE 5
SUCTION LINE LENGTH/SIZE VS. CAPACITY MULTIPLIER (R-22)

Unit Size		1.5 Ton	2 Ton	2.5 Ton	3 Ton	3.5 Ton	4 Ton	5 Ton
Suction Line Connection Size		3/4" I.D. [19.05mm]	3/4" I.D. [19.05mm]	3/4" I.D. [19.05mm]	7/8" I.D. [22.23mm]	7/8" I.D. [22.23mm]	7/8" I.D. [22.23mm]	7/8" I.D. [22.23mm]
Suction Line Run - Feet [m]		5/8 [15.88mm]	5/8 [15.88mm]	5/8 [15.88mm]	3/4 [19.05mm]	3/4 [19.05mm]	7/8 [22.23mm]	7/8 [22.23mm]
		3/4* [19.05mm]*	3/4* [19.05mm]*	3/4* [19.05mm]*	7/8* [22.23mm]*	7/8* [22.23mm]*	1 1/8* [28.58mm]*	1 1/8* [28.58mm]*
		—	7/8	7/8	—	1 1/8	—	—
25' [7.62]	Optional	0.99	0.99	0.98	0.99	0.99	0.99	0.99
	Standard	1.00	1.00	1.00	1.00	1.00	1.00	1.00
	Optional	—	1.00	1.00	—	1.00	—	—
50' [15.24]	Optional	0.97	0.96	0.96	0.98	0.97	0.98	0.97
	Standard	0.99	0.99	0.98	0.99	0.98	0.99	0.99
	Optional	—	0.99	0.99	—	1.00	—	—
100' [30.48]	Optional	0.94	0.92	0.94	0.95	0.93	0.95	0.95
	Standard	0.96	0.96	0.96	0.96	0.96	0.98	0.98
	Optional	—	0.97	0.97	—	0.98	—	—
150' [45.72]	Optional	0.90	0.89	0.92	0.93	0.92	0.93	0.93
	Standard	0.93	0.93	0.93	0.94	0.94	0.96	0.96
	Optional	—	0.95	0.95	—	0.96	—	—

*Standard Line Size
 Note: Using suction line larger than shown in chart will result in poor oil return and is not recommended.

FLOWCHECK PISTON

The flowcheck piston is a multi-purpose device. With flow into the compression nut end from the liquid line, the piston acts as the expansion device with flow through the metering orifice in the center of the piston. The "O" ring on the end of the piston prevents refrigerant from bypassing the metering orifice is centered into a distributor which serves to evenly distribute refrigerant to the evaporator circuits.

It is essential that the evaporator and condensing unit be properly matched. Use only matched components as shown in sales specification sheets.

A piston size that is too small will cause starving and one that is too large will cause flooding. In any case, system performance and reliability will be unacceptable.

If a combination is used that requires a piston size change, the combination cannot be used without changing to the correct size piston (see Table 7).

Change the piston in the distributor on the evaporator before installing the coil and charging the system following the procedure below and using Figure 3:

- Using a back-up wrench on the distributor body, loosen the compression nut to gain access to the piston.
- Using the wire provided with replacement pistons, run (hooked end) through hole in piston.
- Hook nose end of piston and lift gently from distributor body.
- Replace piston with one of proper size. Install piston with gasket end of piston in distributor. Do not force piston into distributor.
- **NOTE:** With piston in distributor, seal end should be down and should not be seen looking in end of distributor. Pistons must be free to rotate and move up and down. Make sure piston is free to move in distributor body.
- Insure distributor gasket is located properly in the distributor body.
- Replace compression nut using back-up wrench on distributor body. Torque compression nut with 8 to 10 ft./lbs [2.4 to 3 m/kg].

TABLE 6
LIQUID LINE SIZING (R-22)

System Capacity	Liquid Line Connection Size (Inch I.D.) [mm]	Line Size (Inch O.D.) [mm]	Liquid Line Size Outdoor unit above Indoor Coil (Cooling Only - Does not apply to Heat Pumps)					
			Total Equivalent Length - Feet [m]					
			25 [7.62]	50 [15.24]	75 [22.86]	100 [30.48]	125 [38.10]	150 [45.72]
			Minimum Vertical Separation - Feet					
1.5 Ton	3/8" [9.53]	1/4 [6.35]*	0①	0①	5 [1.524]	18 [5.49]	31 [9.45]	44 [13.41]
		5/16 [7.94]	0①	0①	0①	0①	0①	0①
		3/8 [9.53]*	0①	0①	0①	0①	0①	0①
2 Ton	3/8" [9.53]	1/4 [6.35]	0①	5 [1.52]	27 [8.23]	48 [14.63]	69 [21.03]	91 [27.74]
		5/16 [7.94]	0①	0①	0①	0①	0①	0①
		3/8 [9.53]*	0①	0①	0①	0①	0①	0①
2.5 Ton	3/8" [9.53]	1/4 [6.35]	0①	34 [10.36]	69 [21.03]	N/A	N/A	N/A
		5/16 [7.94]	0①	0①	0①	0①	9	18
		3/8 [9.53]*	0①	0①	0①	0①	0①	0①
3 Ton	3/8" [9.53]	5/16 [7.94]	0①	0①	0①	6 [1.83]	17 [5.18]	28 [8.53]
		3/8 [9.53]*	0①	0①	0①	0①	0①	0①
3.5 Ton	3/8" [9.53]	5/16 [7.94]	0①	0①	0①	13 [3.96]	28 [8.53]	43 [13.11]
		3/8 [9.53]*	0①	0①	0①	0①	0①	0①
4 Ton	3/8" [9.53]	3/8 [9.53]*	0①	0①	0①	0①	0①	0①
		1/2 [12.7]	0①	0①	0①	0①	0①	0①
5 Ton	3/8" [9.53]	3/8 [9.53]*	0①	0①	0①	0①	0①	9
		1/2 [12.7]	0①	0①	0①	0①	0①	0①
System Capacity	Line Size Connection Size (Inch I.D.) [mm]	Line Size (Inch O.D.) [mm]	Liquid Line Size Cooling Only With Outdoor Unit Below Indoor Coil					
			Total Equivalent Length - Feet [m]					
			25 [7.62]	50 [15.24]	75 [22.86]	100 [30.48]	125 [38.10]	150 [45.72]
			Maximum Vertical Separation - Feet					
1.5 Ton	3/8" [9.53]	1/4 [6.35]	21 [6.40]	8 [8.23]	N/A	N/A	N/A	N/A
		5/16 [7.94]	25 [7.62]	27 [7.62]	24 [7.32]	21 [6.40]	17 [5.18]	14
		3/8 [9.53]*	25 [7.62]	40 [12.19]	39 [11.89]	38 [11.58]	37 [11.28]	35
2 Ton	3/8" [9.53]	1/4 [6.35]	16 [4.88]	N/A	N/A	N/A	N/A	N/A
		5/16 [7.94]	25 [7.62]	26 [7.92]	21 [6.40]	15 [4.57]	10	5 [1.52]
		3/8 [9.53]*	25 [7.62]	38 [11.58]	36 [10.98]	35 [10.67]	33 [10.06]	31
2.5 Ton	3/8" [9.53]	1/4 [6.35]	0	N/A	N/A	N/A	N/A	N/A
		5/16 [7.94]	25 [7.62]	17 [5.18]	8 [8.23]	0	N/A	N/A
		3/8 [9.53]*	25 [7.62]	37 [11.28]	34 [10.36]	31 [9.45]	29	26 [7.92]
3 Ton	3/8" [9.53]	5/16 [7.94]	25 [7.62]	15 [4.57]	4 [1.22]	N/A	N/A	N/A
		3/8 [9.53]*	25 [7.62]	30 [9.14]	26 [7.92]	23 [7.01]	19 [5.79]	16
3.5 Ton	3/8" [9.53]	5/16 [7.94]	25 [7.62]	17 [5.18]	2 [0.61]	N/A	NA	N/A
		3/8 [9.53]*	25 [7.62]	37 [11.28]	32 [9.75]	28 [8.53]	23 [7.01]	18 [5.57]
4 Ton	3/8" [9.53]	3/8 [9.53]*	25 [7.62]	33 [10.06]	27 [8.23]	21 [6.40]	15 [4.57]	9 [2.74]
		1/2 [12.7]	25 [7.62]	43 [13.11]	42 [12.80]	40 [12.19]	39 [11.89]	38 [11.58]
5 Ton	3/8" [9.53]	3/8 [9.53]*	25 [7.62]	25 [7.62]	17 [5.18]	8 [8.23]	0	N/A
		1/2 [12.7]	25 [7.62]	39 [11.89]	37 [11.28]	36 [10.97]	34 [10.36]	32 [9.75]

*Standard line size

N/A = Application not recommended.

① The "Minimum Vertical Separation" is the elevation difference between the outdoor unit being above the indoor coil. A "0" denoted in the table means that there is no elevation requirement (any elevation difference is acceptable).

NOTICE

For proper system operation, it may be necessary to replace the piston installed in the indoor coil. Check the service valves on the outdoor unit to see if a notice tag along with a plastic bag containing a piston is attached. If one is present a change of the piston is required. Failure to change the piston can result in improper performance of the system or component failure.

- Original piston size is stamped on outside of distributor body. Remove new piston size label from poly bag new piston came in and install new size label on outside of distributor tube.
- Check fittings for leaks after installation, evacuation and charging is complete.

IMPORTANT: Do not attempt to drill pistons to size in the field. Metering holes have a special chamfered inlet and cannot be modified.

IMPORTANT: Do not replace the neoprene “O” ring on the piston with any type of seal. contact the parts department for the exact replacement “O” ring.

EVACUATION PROCEDURE

Evacuation is the most important part of the entire service procedure. The life and efficiency of the equipment is dependent upon the thoroughness exercised by the serviceman when evacuating air and moisture from the line set and indoor coil.

Air in the system causes high condensing temperatures and pressure, resulting in increased power input and non-verifiable performance.

Moisture chemically reacts with the refrigerant and oil to form corrosive hydrofluoric and hydrochloric acids. These attack motor windings and parts, causing breakdown.

After the system has been leak checked and proven sealed, connect the vacuum pump and evacuate system to 500 microns. The vacuum pump must be connected to both the high and low sides of the system through adequate connections. Use the largest size connections available since restrictive service connections may lead to false readings because of pressure drop through the fittings.

IMPORTANT: Compressors (especially scroll type) should never be used to evacuate the air conditioning system because internal electrical arcing may result in a damaged or failed compressor.

FIGURE 3
PISTON AND DISTRIBUTOR ASSEMBLY

NOTE: PISTON, TEFLON PISTON SEAL AND INSIDE OF DISTRIBUTOR MUST BE CLEAN AND FREE OF NICKS, BURRS OR OTHER DAMAGE.

NOTE: DO **NOT** REPLACE NEOPRENE SEAL WITH ANY “O” RING. ONLY USE FACTORY REPLACEMENT PARTS.

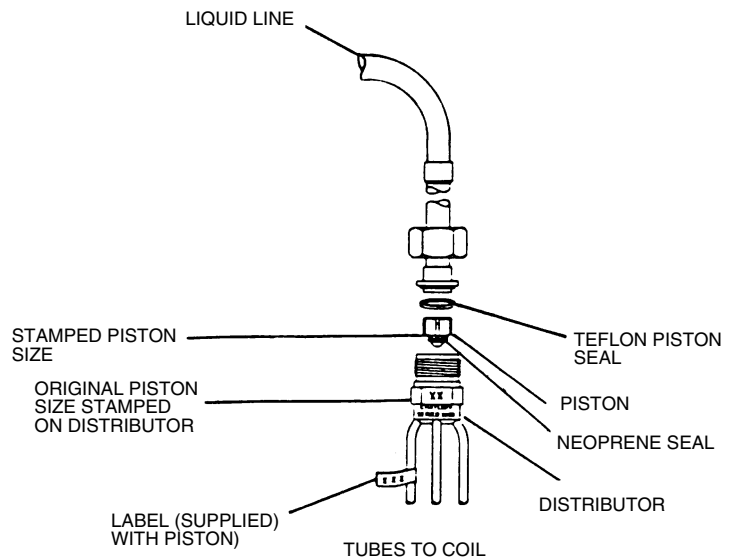

TABLE 7
PISTON SIZES #61-25414-XX

Outdoor Unit Model and Size	Highest Volume Indoor Coil	Piston Size
(-)AKB-018	RCBA-2457	51
(-)AKB-024	RCBA-2457	57
(-)AKB-030	RCBA-3665	65
(-)AKB-036	RCBA-3665	65
(-)AKB-042	RCBA-4882	73
(-)AKB-048	RCBA-4882	82
(-)AKB-060	RCBA-6089	89
(-)AKB-065	RCBA-6089	89
(-)APC-024	RCGJ-24A2	120
(-)APC-030	RCGJ-36A1	120
(-)APC-036	RCGJ-36A2	140
(-)APC-042	RCGJ-48A1	140
(-)APC-048	RCGJ-60A1	157
(-)APC-060	RCGJ-60A1	157
(-)APC-024	RCQC-3117AS	N/A
(-)APC-030	RCQC-3121AS	N/A
(-)APC-036	RCQC-4821AS	N/A

NOTE: No piston required for (-)AND.
 Change piston for AKB-018 to #51.

START UP AND PERFORMANCE

Even though the unit is factory charged with Refrigerant-22, the charge must be checked to the charge table attached to the service panel and adjusted, if required. Allow a minimum of 5 minutes running. Before analyzing charge, see the instructions on the unit service panel rating plate for marking the total charge.

- The service valves are not backseating valves. To open the valves, remove the valve cap with an adjustable wrench. Insert a 3/16" [4.8 mm] or 5/16" [7.9 mm] hex wrench into the stem. Back out counterclockwise until it stops.
- Replace the valve cap finger tight then tighten an additional 1/8 of a turn for a metal-to-metal seal.

CHECKING AIRFLOW

The air distribution system has the greatest effect. The duct system is totally controlled by the contractor. For this reason, the contractor should use only industry-recognized procedures.

The correct air quantity is critical to air conditioning systems. Proper operation, efficiency, compressor life, and humidity control depend on the correct balance between indoor load and outdoor unit capacity. Excessive indoor airflow increases the possibility of high humidity problems. Low indoor airflow reduces total capacity, and causes coil icing. Serious harm can be done to the compressor by low airflow, such as that caused by refrigerant flooding.

Air conditioning systems require a specified airflow. Each ton of cooling requires between 350 and 450 cubic feet of air per minute (CFM), or 400 CFM nominally.

Duct design and construction should be carefully done. System performance can be lowered dramatically through bad planning or workmanship.

Air supply diffusers must be selected and located carefully. They must be sized and positioned to deliver treated air along the perimeter of the space. If they are too small for their intended airflow, they become noisy. If they are not located properly, they cause drafts. Return air grilles must be properly sized to carry air back to the blower. If they are too small, they also cause noise.

The installers should balance the air distribution system to ensure proper quiet airflow to all rooms in the home. This ensures a comfortable living space.

These simple mathematical formulas can be used to determine the CFM in a residential or light commercial system.

Electric resistance heaters can use

$$CFM = \frac{\text{volts} \times \text{amps} \times 3.414}{1.08 \times \text{temp rise}}$$

Gas furnaces can use

$$CFM = \frac{BTUH}{\Delta T \times 1.08}$$

An air velocity meter or airflow hood can give a more accurate reading of the system CFM.

CHECKING REFRIGERANT CHARGE

Charge for all systems should be checked against the Charging Chart inside the access panel cover. Before using the chart, the indoor conditions must be within 2°F [16°C] of desired comfort conditions and system must be run until operating conditions stabilize (15 min. to 30 min.)

CAUTION

THE TOP OF THE SCROLL COMPRESSOR SHELL IS HOT. TOUCHING THE COMPRESSOR TOP MAY RESULT IN SERIOUS PERSONAL INJURY.

IMPORTANT: Do not operate the compressor without charge in system.

Addition of R-22 will raise pressures (vapor, liquid and discharge) and lower vapor temperature.

If adding R-22 raises both vapor pressure and temperature, the unit is overcharged.

IMPORTANT: Use industry-approved charging methods to ensure proper system charge.

CHARGING BY SUPERHEAT

Superheat charging method is used for charging systems when a flowcheck piston or capillary tubes are used on the evaporator as a metering device.

Pressure reading and charging is accomplished using the service port located on the vapor service valve (large valve) located on the base pan. (See Figure 1.)

Vapor temperature readings must be taken on the vapor line going from the vapor service valve (large valve) and the compressor. A remote temperature indicator is most convenient. If this is not available, a thermistor properly located and insulated can be used.

Measure and record the three values required. Find the intersection of vapor line pressure and outdoor ambient on the charging chart. The vapor line temperature should approximate the intersect value on the chart.

The most likely causes for the intersection of vapor pressure and ambient temperature in the open area to (left) or (right) of table values are: (Left): Low charge, low load; (Right): Overcharge, high load.

CHARGING BY LIQUID PRESSURE

Liquid pressure method is used for charging systems in the cooling mode when an expansion valve is used on the evaporator. The service port on the liquid service valve (small valve) is used for this purpose.

Read and record the outdoor ambient temperature entering the condensing unit, and the liquid line pressure at the service valve (the small valve). Locate the charging chart attached to the unit. The correct liquid line pressure will be found by finding the intersection of the unit model size and the outdoor ambient temperature. Adjust the liquid line pressure but either adding refrigerant to raise pressure or removing refrigerant to lower pressure.

CHARGING BY WEIGHT

For a new installation, evacuation of interconnecting tubing and evaporator coil is adequate; otherwise, evacuate the entire system. Use the factory charge shown in Tables 1 through 3 of these instructions or unit data plate. Note that charge value includes charge required for 15 feet [(-)AND only] or 25 feet [(-)AKB (3 phase models only), and (-)APC] of standard size interconnecting liquid line. Calculate actual charge required with installed liquid line size and length using:

1/4" [6.4 mm] O.D. = .3 oz./ft. [8.5 g/m]

5/16" [7.9 mm] O.D. = .4 oz./ft. [11.3 g/m]

3/8" [9.5 mm] O.D. = .6 oz./ft. [17 g/m]

1/2" [12.7 mm] O.D. = 1.2 oz./ft. [34 g/m]

With an accurate scale (+/- 1 oz. [28.4 g]) or volumetric charging device, adjust charge difference between that shown on the unit data plate and that calculated for

the new system installation. If the entire system has been evacuated, add the total calculated charge.

NOTE: When the total refrigerant charge volume exceeds the values in Tables 1, 2 and 3, the manufacturer recommends installing a crankcase heater and start kit.

FINAL LEAK TESTING

After the unit has been properly evacuated and charged, a halogen leak detector should be used to detect leaks in the system. All piping within the condensing unit, evaporator, and interconnecting tubing should be checked for leaks. If a leak is detected, the refrigerant should be recovered before repairing the leak. The Clean Air Act prohibits venting refrigerant into the atmosphere.

WARNING

TURN OFF ELECTRIC POWER AT THE FUSE BOX OR SERVICE PANEL BEFORE MAKING ANY ELECTRICAL CONNECTIONS.

ALSO, THE GROUND CONNECTION MUST BE COMPLETED BEFORE MAKING LINE VOLTAGE CONNECTIONS. FAILURE TO DO SO CAN RESULT IN ELECTRICAL SHOCK, SEVERE PERSONAL INJURY OR DEATH.

ELECTRICAL WIRING

Field wiring must comply with the National Electric Code (C.E.C. in Canada) and any applicable local code.

GROUNDING

A grounding lug is provided near the contactor for a ground wire.

WARNING

THE UNIT MUST BE PERMANENTLY GROUNDED. FAILURE TO DO SO CAN CAUSE ELECTRICAL SHOCK RESULTING IN SEVERE PERSONAL INJURY OR DEATH.

POWER WIRING

It is important that proper electrical power from a commercial utility is available at the condensing unit contactor. Voltage ranges for operation are shown in Table 8.

Install a branch circuit disconnect within sight of the unit and of adequate size to handle the starting current (see Tables 1 through 3).

Power wiring must be run in a rain-tight conduit. Conduit must be run through the connector panel below the access cover (see Figure 1) and attached to the bottom of the control box.

Connect power wiring to contactor located in outdoor condensing unit electrical box. (See wiring diagram attached to unit access panel.)

Check all electrical connections, including factory wiring within the unit and make sure all connections are tight.

DO NOT connect aluminum field wire to the contactor terminals.

TABLE 8
VOLTAGE RANGES (60 HZ)

Nameplate Voltage	Operating Voltage Range at Copeland Maximum Load Design Conditions for Compressors
208/230 (1 Phase)	197 - 253
208/230 (3 Phase)	187 - 253
460	414 - 506
575	517 - 633

FIGURE 4
CONTROL WIRING FOR GAS OR ELECTRIC HEAT

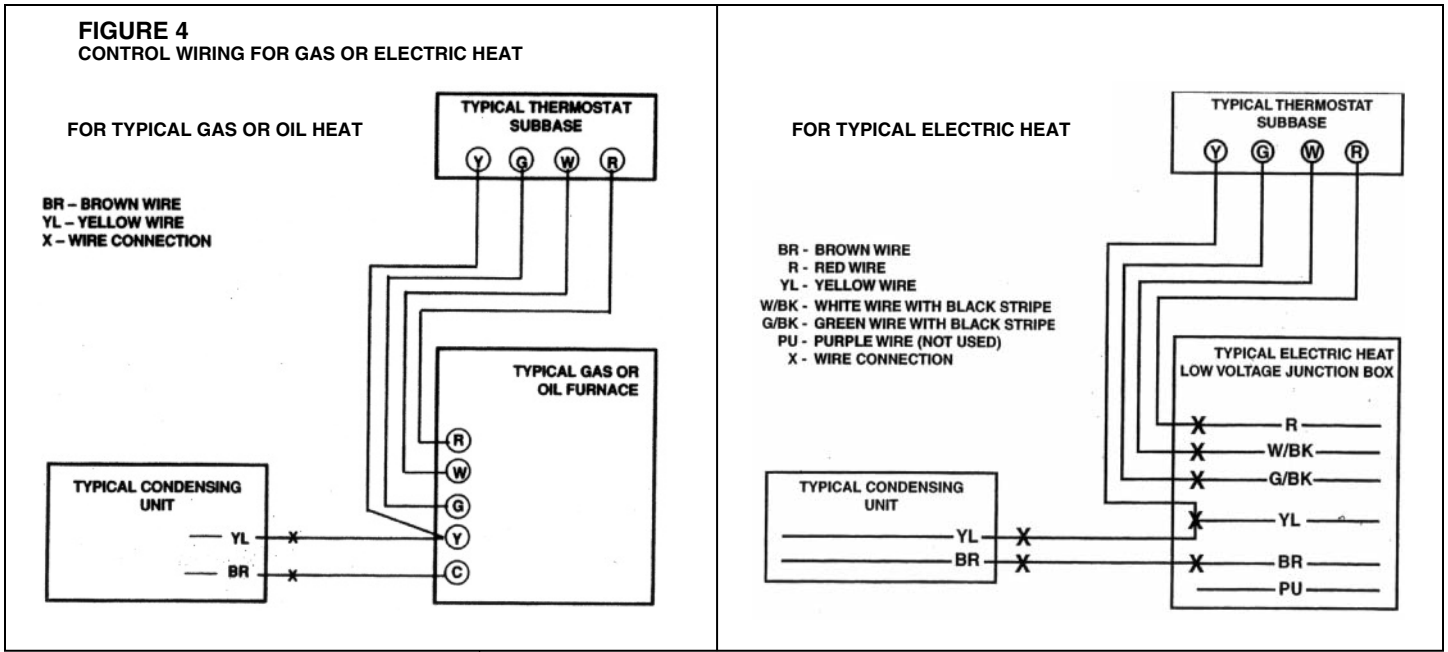

TABLE 9
FIELD WIRE SIZE FOR 24 VOLT THERMOSTAT CIRCUITS

Thermostat Load - Amps	SOLID COPPER WIRE - AWG.					
	3.0	16	14	12	10	10
2.5	16	14	12	12	10	10
2.0	18	16	14	12	12	10
	50	100	150	200	250	300
	Length of Run - Feet (1)					

(1) Wire length equals twice the run distance.

NOTE: Do not use control wiring smaller than No. 18 AWG between thermostat and outdoor unit.

CONTROL WIRING

(See Figure 4)

If the low voltage control wiring is run in conduit with the power supply, Class I insulation is required. Class II insulation is required if run separate. Low voltage wiring may be run through the insulated bushing provided in the 7/8 hole in the base panel, up to and attached to the pigtails from the bottom of the control box. Conduit can be run to the base panel if desired by removing the insulated bushing.

A thermostat and a 24 volt, 40 VA minimum transformer are required for the control circuit of the condensing unit. The furnace or the air handler transformer may be used if sufficient. See the wiring diagram for reference. Use 18-gauge thermostat wire only.

FIELD INSTALLED ACCESSORIES

COMPRESSOR CRANKCASE HEAT (CCH)

While scroll compressors usually do not require crankcase heaters, there are instances when a heater should be added. Refrigerant migration during the off cycle can result in a noisy start up. Add a crankcase heater to minimize refrigeration migration, and to help eliminate any start up noise or bearing "wash out."

NOTE: A crankcase heater should be installed if: the charge of the system exceeds the values in Tables 1, 2 and 3, if the system is subject to voltage variations or when a low ambient control is used for system operation below 55°F [13°C].

All heaters are located on the lower half of the compressor shell. Its purpose is to drive refrigerant from the compressor shell during long off cycles, thus preventing damage to the compressor during start-up.

At initial start-up or after extended shutdown periods, make sure the heater is energized for at least 12 hours before the compressor is started. (Disconnect switch on and wall thermostat off.)

HARD START COMPONENTS

Start components are required with all non-bleed expansion valve coils only on models with reciprocating compressors {(-)AKB-????AS}. Available for order through PROSTOCK®.

TIME DELAY CONTROL (TDC)

The time delay (TDC) is in the low voltage control circuit. When the compressor shuts off due to a power failure or thermostat operation, this control keeps it off at least 5 minutes which allows the system pressure to equalize, thus not damaging the compressor or blowing fuses on start-up.

LOW AMBIENT CONTROL (LAC)

This component senses compressor head pressure and shuts the condenser fan off when the head pressure drops to approximately 175 PSIG. This allows the unit to build a sufficient head pressure at lower ambient in order to maintain system balance and obtain improved capacity. Low ambient control should be used on all equipment operated below 70°F [21°C] ambient.

HIGH AND LOW PRESSURE CONTROLS (HPC OR LPC)

These controls keep the compressor from operating in pressure ranges which can cause damage to the compressor. Both controls are in the low voltage control circuit.

High pressure control (HPC) is a manual reset which opens near 610 PSIG. Do not reset arbitrarily without first determining what caused it to trip.

The low pressure control (LPC) is an automatic reset which opens near 50 PSIG and closes near 95 PSIG.

NOTE: High and low pressure controls are standard on all (-)AND and (-)APC models.

SERVICE

OPERATION

Most single phase units are operated PSC (no starting components). It is important that such systems be off for a minimum of 5 minutes before restarting to allow equalization of pressure. The thermostat should not be moved to cycle unit without waiting 5 minutes. To do so may cause the compressor to go off on an automatic overload device or blow a fuse. Poor electrical service can also cause nuisance tripping on overloads, trip a breaker, or cause light dimming. This generally can be corrected by adding start components. Check with factory for recommended start components, if required. For PSC type operation, refrigerant metering must be done with fixed orifice, cap tubes or bleed type expansion valves because of low starting torque. If non-bleed expansion valve coils (supplied by factory) are used, start components are required.

SINGLE-POLE COMPRESSOR CONTACTOR (CC)

Single-pole contactors are used on all standard single phase units up through 5 tons. Caution must be exercised when servicing as only one leg of the power supply is broken with the contactor. Two pole contactors are used on some three phase units.

TROUBLE SHOOTING

In diagnosing common faults in the air conditioning system, it is useful to present the logical pattern of thought that is used by experienced technicians. The charts which follow are not intended to be an answer to all problems, but only to guide your thinking as you attempt to decide on your course of action. Through a series of yes and no answers, you will follow the logical path to a likely conclusion.

Use these charts as you would a road map, if you are a beginning technician. As you gain experience, you will learn where to establish the shortcuts. Remember that the chart will help clarify the logical path to the problem.

ELECTRICAL CHECKS FLOW CHART

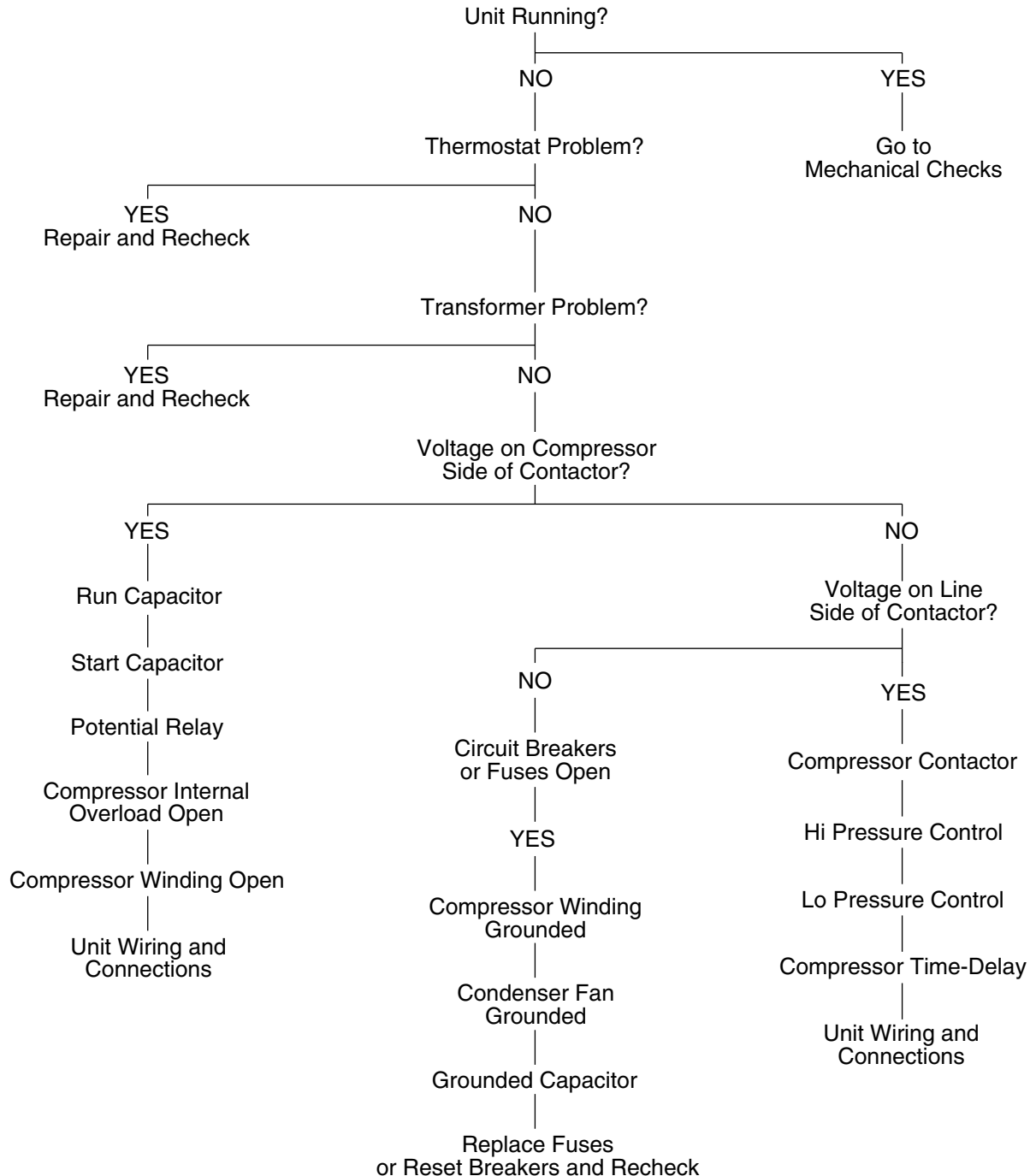

MECHANICAL CHECKS FLOW CHART

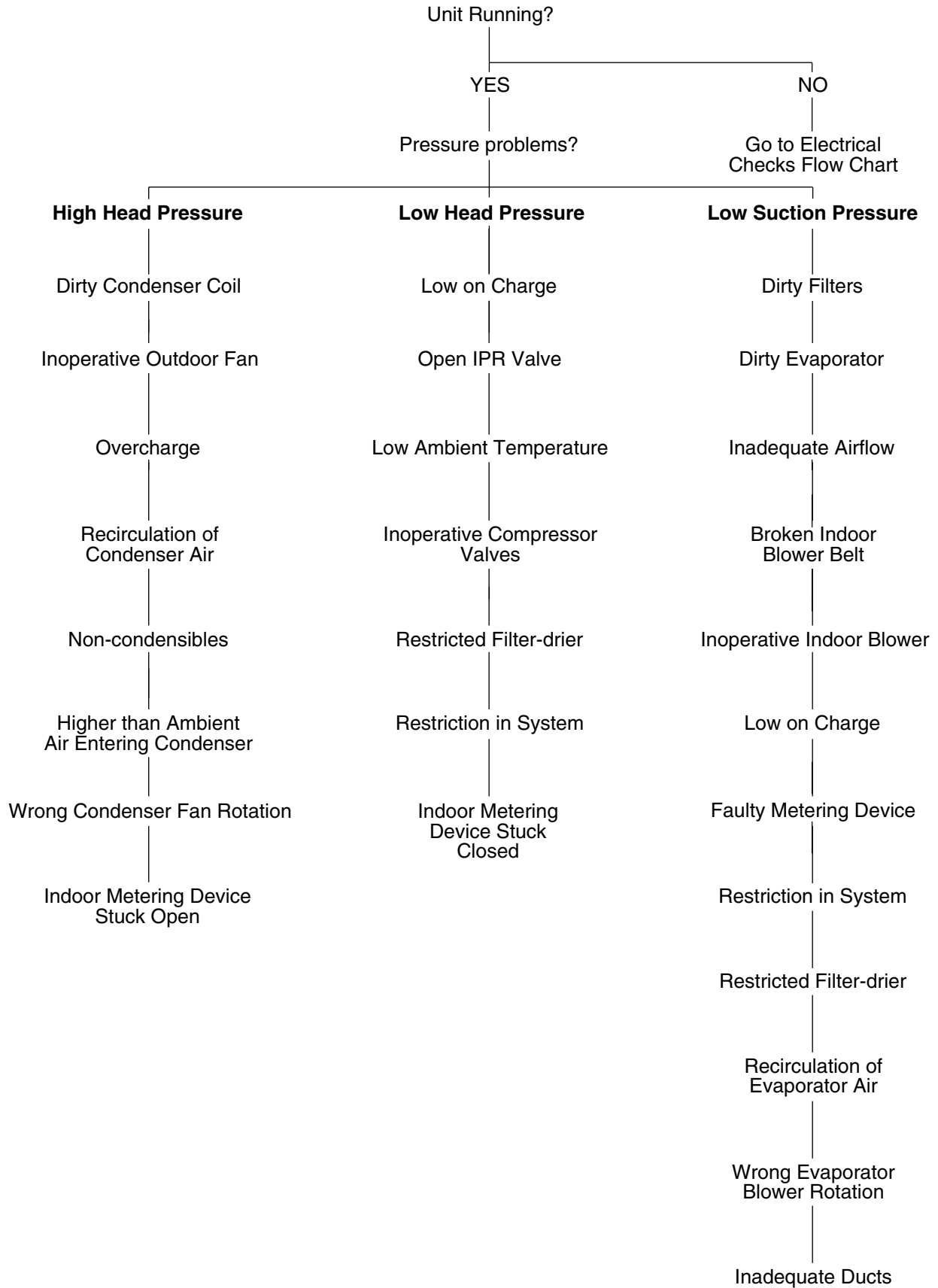

TABLE 10
TEMPERATURE PRESSURE CHART

TEMP (Deg. F)[C]	R-22 PSIG
-150 [-101]	*29.4
-140 [-95]	*29.1
-130 [-90]	*28.5
-120 [-84]	*27.7
-110 [-79]	*26.6
-100 [-73]	*25.1
-90 [-68]	*23.0
-80 [-62]	*20.2
-70 [-57]	16.6
-60 [-51]	*11.9
-50 [-46]	*6.1
-40 [-40]	0.6
-35 [-37]	2.6
-30 [-34]	4.9
-25 [-32]	7.5
-20 [-29]	10.2
-15 [-26]	13.2
-10 [-23]	16.5
-5 [-21]	20.1
0 [-18]	24.0
5 [-15]	28.3
10 [-12]	32.8
15 [-9]	37.8
20 [-7]	43.1
25 [-4]	48.8
30 [-1]	54.9
35 [2]	61.5
40 [4]	68.5
45 [7]	76.1
50 [10]	84.1
55 [13]	92.6
60 [16]	101.6
65 [18]	111.3
70 [21]	121.4
75 [24]	132.2
80 [27]	143.7
85 [29]	155.7
90 [32]	168.4
95 [35]	181.8
100 [38]	196.0
105 [41]	210.8
110 [43]	226.4
115 [46]	242.8
120 [49]	260.0
125 [52]	278.1
130 [54]	297.0
135 [57]	316.7
140 [60]	337.4
145 [63]	359.1
150 [66]	381.7

SUPERHEAT CALCULATION

1. Measure the suction pressure at the suction line service valve.
2. Convert the suction pressure to saturated temperature. See Table 10.
3. Measure the temperature of the suction line at the suction line service valve.
4. Compare the temperature of the suction line to the saturated temperature.
5. The difference between saturated temperature and suction line temperature is the superheat. Superheat normal range 12° to 15°.

SUBCOOLING CALCULATION

1. Measure the liquid pressure at the liquid line service valve.
2. Convert the liquid line pressure to saturated temperature. See Table 10.
3. Measure the liquid line temperature at the liquid line service valve.
4. Compare the liquid line temperature to the saturated temperature.
5. The difference between saturated temperature and liquid line temperature is the subcooling. Subcooling normal range 9° to 12°.

TABLE 11
AIR CONDITIONING SYSTEM TROUBLESHOOTING TIPS

AIR CONDITIONING SYSTEM TROUBLESHOOTING TIPS					
SYSTEM PROBLEM	INDICATORS				
	DISCHARGE PRESSURE	SUCTION PRESSURE	SUPERHEAT	SUBCOOLING	COMPRESSOR AMPS
Overcharge	High	High	Low	High	High
Undercharge	Low	Low	High	Low	Low
Liquid Restriction (Drier)	Low	Low	High	High	Low
Low Evaporator Airflow	Low	Low	Low	Low	Low
Dirty Condenser	High	High	Low	Low	High
Low Outside Ambient Temperature	Low	Low	High	High	Low
Inefficient Compressor	Low	High	High	High	Low
TEV Feeler Bulb Charge Lost	Low	Low	High	High	Low
Poorly Insulated Sensing Bulb	High	High	Low	Low	High

TROUBLE SHOOTING CHART

▲ WARNING

DISCONNECT ALL POWER TO UNIT BEFORE SERVICING. CONTACTOR MAY BREAK ONLY ONE SIDE. FAILURE TO SHUT OFF POWER CAN CAUSE ELECTRICAL SHOCK RESULTING IN PERSONAL INJURY OR DEATH.

SYMPTOM	POSSIBLE CAUSE	REMEDY
Unit will not run	<ul style="list-style-type: none"> • Power off or loose electrical connection • Thermostat out of calibration-set too high • Defective contactor • Blown fuses / tripped breaker • Transformer defective • High pressure control open (if provided) 	<ul style="list-style-type: none"> • Check for correct voltage at contactor in condensing unit • Reset • Check for 24 volts at contactor coil - replace if contacts are open • Replace fuses / reset breaker • Check wiring-replace transformer • Reset-also see high head pressure remedy-The high pressure control opens at 450 PSIG
Outdoor fan runs, compressor doesn't	<ul style="list-style-type: none"> • Run or start capacitor defective • Start relay defective • Loose connection • Compressor stuck, grounded or open motor winding, open internal overload. • Low voltage condition 	<ul style="list-style-type: none"> • Replace • Replace • Check for correct voltage at compressor - check & tighten all connections • Wait at least 2 hours for overload to reset. If still open, replace the compressor. • Add start kit components
Insufficient cooling	<ul style="list-style-type: none"> • Improperly sized unit • Improper indoor airflow • Incorrect refrigerant charge • Air, non-condensibles or moisture in system 	<ul style="list-style-type: none"> • Recalculate load • Check - should be approximately 400 CFM per ton. • Charge per procedure attached to unit service panel • Recover refrigerant, evacuate & recharge, add filter drier
Compressor short cycles	<ul style="list-style-type: none"> • Incorrect voltage • Defective overload protector • Refrigerant undercharge 	<ul style="list-style-type: none"> • At compressor terminals, voltage must be $\pm 10\%$ of nameplate marking when unit is operating. • Replace - check for correct voltage • Add refrigerant
Registers sweat	<ul style="list-style-type: none"> • Low indoor airflow 	<ul style="list-style-type: none"> • Increase speed of blower or reduce restriction - replace air filter
High head-low vapor pressures	<ul style="list-style-type: none"> • Restriction in liquid line, expansion device or filter drier • Flowcheck piston size too small • Incorrect capillary tubes 	<ul style="list-style-type: none"> • Remove or replace defective component • Change to correct size piston • Change coil assembly
High head-high or normal vapor pressure - Cooling mode	<ul style="list-style-type: none"> • Dirty outdoor coil • Refrigerant overcharge • Outdoor fan not running • Air or non-condensibles in system 	<ul style="list-style-type: none"> • Clean coil • Correct system charge • Repair or replace • Recover refrigerant, evacuate & recharge
Low head-high vapor pressures	<ul style="list-style-type: none"> • Flowcheck piston size too large • Defective Compressor valves • Incorrect capillary tubes 	<ul style="list-style-type: none"> • Change to correct size piston • Replace compressor • Replace coil assembly
Low vapor - cool compressor - iced indoor coil	<ul style="list-style-type: none"> • Low indoor airflow • Operating below 65°F [18°C] outdoors • Moisture in system 	<ul style="list-style-type: none"> • Increase speed of blower or reduce restriction - replace air filter • Add Low Ambient Kit • Recover refrigerant - evacuate & recharge - add filter drier
High vapor pressure	<ul style="list-style-type: none"> • Excessive load • Defective compressor 	<ul style="list-style-type: none"> • Recheck load calculation • Replace
Fluctuating head & vapor pressures	<ul style="list-style-type: none"> • TEV hunting • Air or non-condensibles in system 	<ul style="list-style-type: none"> • Check TEV bulb clamp - check air distribution on coil - replace TEV • Recover refrigerant, evacuate & recharge
Gurgle or pulsing noise at expansion device or liquid line	<ul style="list-style-type: none"> • Air or non-condensibles in system 	<ul style="list-style-type: none"> • Recover refrigerant, evacuate & recharge

FIGURE 5
SINGLE-PHASE UNITS EMPLOYING KICKSTART® COMPONENTS WIRING DIAGRAM

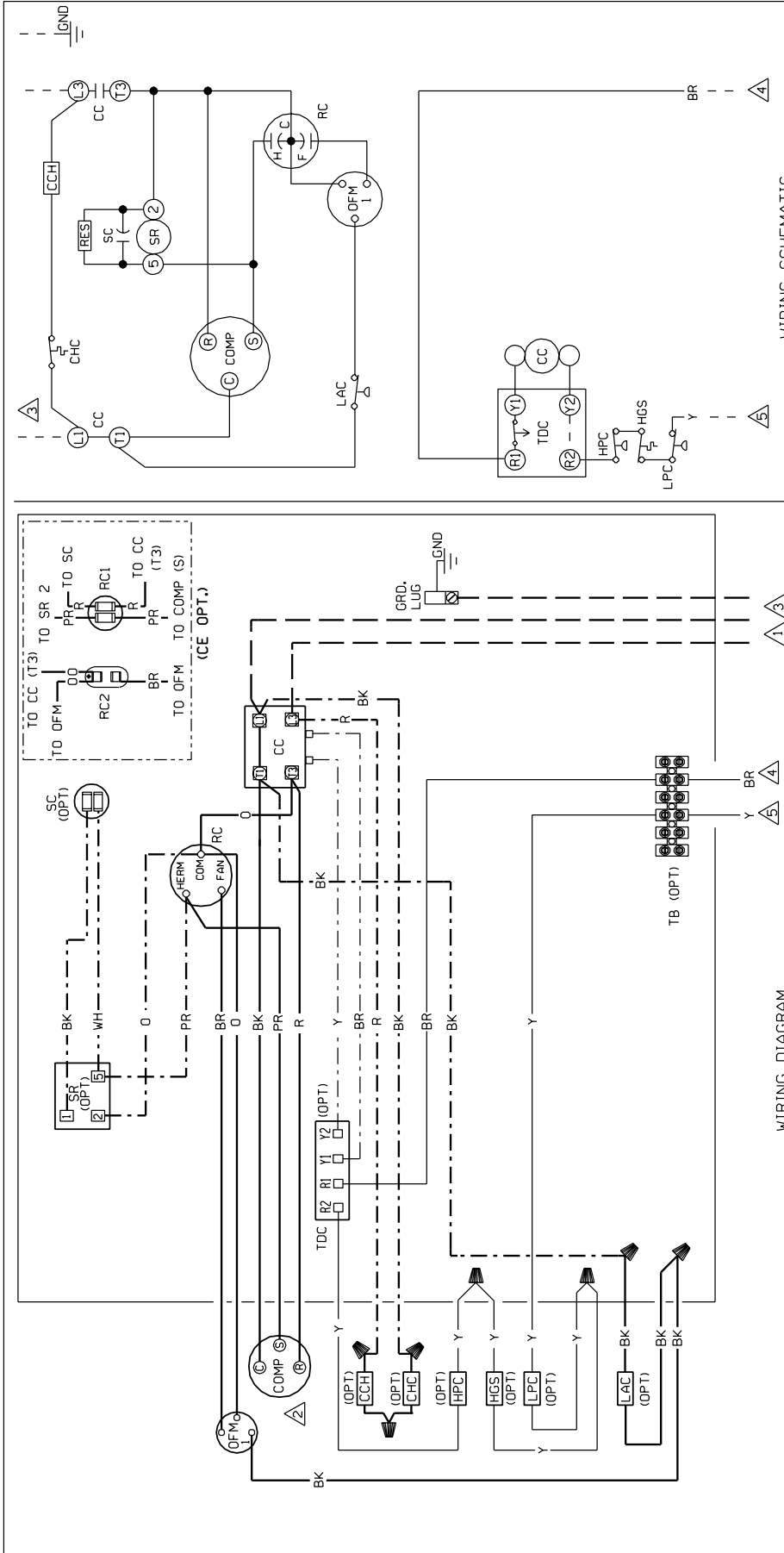

COMPONENT CODE		WIRE COLOR CODE	
CCH	COMPRESSOR CONTACTOR	BK	BLACK
CHC	CRANKCASE HEATER CONTROL	BR	BROWN
COMP	COMPRESSOR	BL	BLUE
COND	CONDENSING UNIT	G	GREEN
CRK	CRANKCASE HEATER	GY	GRAY
FAN	FAN MOTOR	O	ORANGE
HPC	HIGH PRESSURE CONTROL	PR	PURPLE
HPS	HIGH PRESSURE SWITCH	R	RED
LAC	LOW AMBIENT CONTROL	W	WHITE
LPC	LOW PRESSURE CONTROL	Y	YELLOW
OFM	OUTDOOR FAN MOTOR		
PTCR	POSITIVE TEMPERATURE COEFFICIENT RELAY		
RC	RUN CAPACITOR		
RES	RESISTOR		
SC	START CAPACITOR		
TB	TERMINAL BLOCK		
TDC	TIME DELAY CONTROL		

WIRING INFORMATION	
LINE VOLTAGE	STANDARD
-FACTORY OPTION	OPTION
-FIELD INSTALLED	---
LOW VOLTAGE	---
-FACTORY OPTION	---
-FIELD INSTALLED	---
REPLACEMENT WIRE	---
-MUST BE THE SAME SIZE AND TYPE OF INSULATION AS ORIGINAL (105 C.MIN.)	
-WARNING: CABINET MUST BE PERMANENTLY GROUNDED AND CONFORM TO I.E.C., N.E.C., C.E.C., NATIONAL WIRING REGULATIONS, AND LOCAL CODES AS APPLICABLE.	

ELECTRICAL WIRING DIAGRAM	
CONDENSING UNIT	
SINGLE PHASE	

DR. BY	APP. BY	DATE	DWG. NO.	REV
MCB		5-26-05	90-23238-11	00

- NOTES:**
- CONNECTORS SUITABLE FOR USE WITH COPPER CONDUCTORS ONLY.
 - COMPRESSOR MOTOR THERMALLY PROTECTED AND ALL 3 PHASE ARE PROTECTED UNDER PRIMARY SINGLE PHASE CONDITIONS.
 - CONNECT FIELD WIRING IN GROUNDED RAINTIGHT CONDUIT TO CASE DISCONNECT, VOLTAGE, HERTZ AND PHASE PER RATING PLATE.
 - LOW VOLTAGE CIRCUIT TO BE MECC. CLASS 2 WITH A CLASS 2 TRANSFORMER 24 VOLT, 50 OR 60 HERTZ.
 - TO THERMOSTAT SUB-BASE, REFER TO SYSTEM SCHEMATICS OR SCHEMATICS ON INDOOR SECTION FOR LOW VOLTAGE CONTROL WIRING.
 - BLACK WIRE FROM SR (S) TO CC (T) DELETED WHEN PTCR IS USED.

DWG. NO.	REV
90-23238-11	00

FIGURE 6
THREE-PHASE UNITS WIRING DIAGRAM

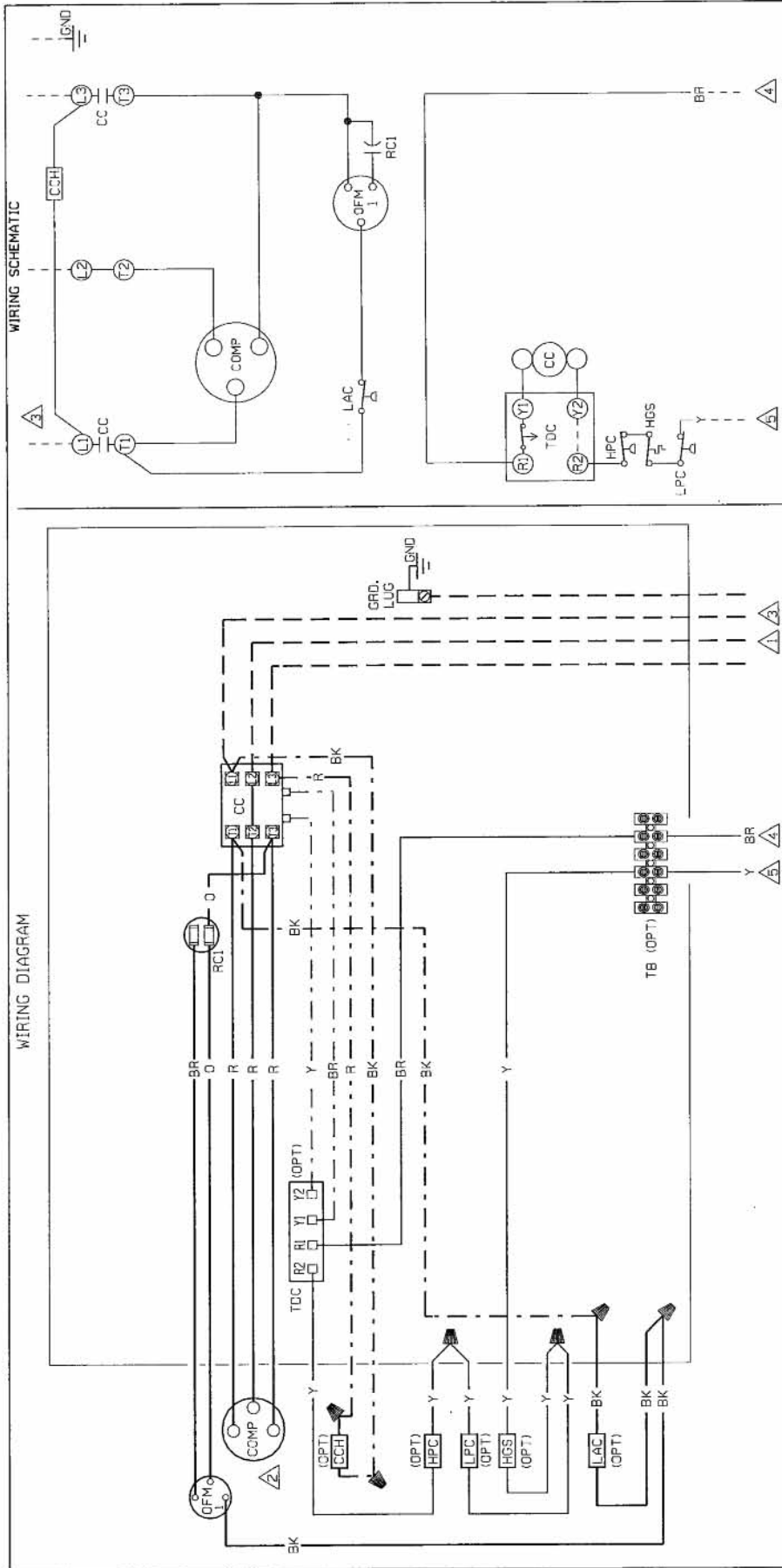

COMPONENT CODE

CC	COMPRESSOR CONTACTOR
CCH	COMPRESSOR CONTACTOR HEATER
COMP	COMPRESSOR
GND	GROUND, CHASSIS
HGS	HOT GAS SENSOR
LPC	LOW PRESSURE CONTROL
LAC	LOW PRESSURE CONTROL
OPT	OPTIONAL
RC	RUN CAPACITOR
SC	START CAPACITOR
SR	START RELAY
TB	TERMINAL BLOCK
TDC	TIME DELAY CONTROL

WIRE COLOR CODE

BK	BLACK	OR	ORANGE
BR	BROWN	PR	PURPLE
BL	BLUE	R	RED
G	GREEN	W	WHITE
GY	GRAY	Y	YELLOW

ELECTRICAL WIRING DIAGRAM
REMOTE AIR CONDITIONER
THREE PHASE

WIRING INFORMATION

- LINE VOLTAGE STANDARD
- FACTORY OPTION
- FIELD INSTALLED
- LOW VOLTAGE
- FACTORY STANDARD
- FACTORY OPTION
- FIELD INSTALLED
- REPLACEMENT WIRE
- MUST BE THE SAME SIZE AND TYPE OF INSULATION AS ORIGINAL (105 C. MIN.)
- WARNING
- CABINET MUST BE PERMANENTLY GROUNDED AND CONFORM TO I.E.C., N.E.C., C.E.C., NATIONAL WIRING REGULATIONS, AND LOCAL CODES AS APPLICABLE.

NOTES:

- CONNECTORS SUITABLE FOR USE WITH COPPER CONDUCTORS ONLY.
- COMPRESSOR MOTOR THERMALLY PROTECTED AND ALL 3 PHASES ARE PROTECTED UNDER PRIMARY SINGLE PHASE CONDITIONS.
- CONNECT FIELD WIRING IN ENCLOSED RAINTIGHT CONDUIT TO USED DISCONNECT, VOLTAGE, HERTZ AND PHASE PER RATING PLATE.
- LOW VOLTAGE CIRCUIT TO BE N.E.C. CLASS 2 WITH A CLASS 2 TRANSFORMER 24 VOLT, 50 OR 60 HERTZ.
- TO THERMOSTAT SUB-BASE; REFER TO SYSTEM SCHEMATICS OR SCHEMATICS ON INDOOR SECTION FOR LOW VOLTAGE CONTROL WIRING.

WIRING SCHEMATIC

WIRING DIAGRAM

DWG. NO. 90-23238-02

DR. BY MB APPR. BY JW DATE 1-28-92 DWG. NO. 90-23238-02

REV 08

FIGURE 7
SINGLE-PHASE UNITS WIRING DIAGRAM

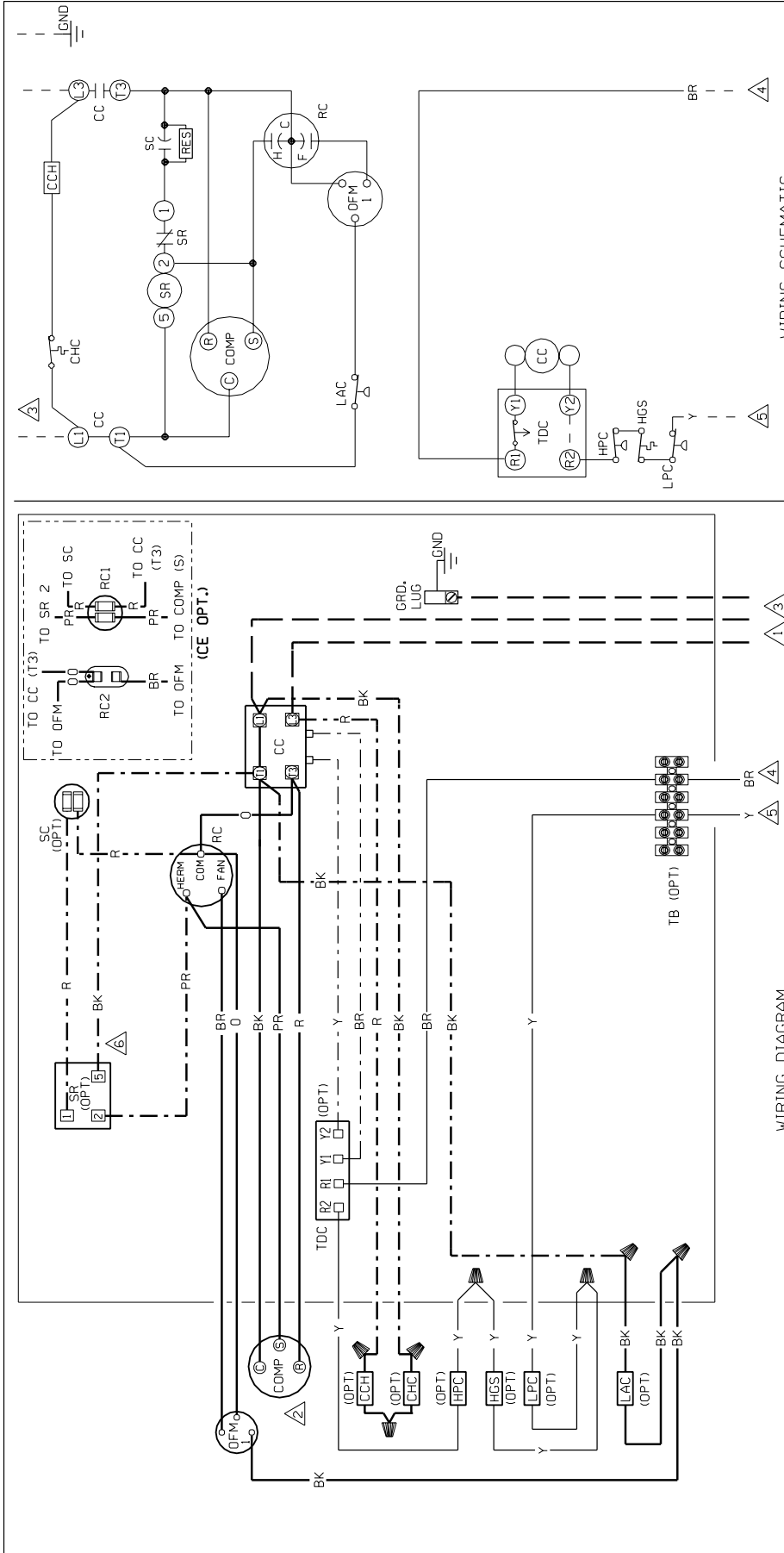

WIRING SCHEMATIC

WIRING DIAGRAM

<p>COMPONENT CODE</p> <p>CCH COMPRESSOR CONTACTOR CHC CRANKCASE HEATER CONTROL COMP COMPRESSOR HGS HIGH PRESS. SENSOR HPC HIGH PRESS. CUT-OUT CONTROL LAC LOW AMBIENT COOLING CONTROL LFC LOW PRESSURE CONTROL OPT OUTDOOR FAN MOTOR PTCR POSITIVE TEMPERATURE COEFFICIENT RELAY RC RUN CAPACITOR RES RESISTOR SC START CAPACITOR TB TERMINAL BLOCK TDC TIME DELAY CONTROL</p>	<p>WIRE COLOR CODE</p> <p>BK BLACK BR BROWN BL BLUE G GREEN CY GRAY O ORANGE PR PURPLE R RED W WHITE Y YELLOW</p>	<p>WIRING INFORMATION</p> <p>LINE VOLTAGE STANDARD -FACTORY OPTION -FIELD INSTALLED LOW VOLTAGE -FACTORY STANDARD -FIELD INSTALLED REPLACEMENT WIRE -MUST BE THE SAME SIZE AND TYPE OF INSULATION AS ORIGINAL (105 C. MIN.)</p>	<p>NOTES:</p> <ol style="list-style-type: none"> CONNECTORS SUITABLE FOR USE WITH COPPER CONDUCTORS ONLY. COMPRESSOR MOTOR THERMALLY PROTECTED AND ALL 3 PHASE ARE PROTECTED UNDER PRIMARY SINGLE PHASE CONDITIONS. CONNECT FIELD WIRING IN GROUNDED RAIN-TIGHT CONDUIT TO FUSE DISCONNECT, VOLTAGE, HERTZ AND PHASE PER RATING PLATE. LOW VOLTAGE CIRCUIT TO BE N.E.C. CLASS 2 WITH A CLASS 2 TRANSFORMER 24 VOLT, 50 OR 60 HERTZ. TO THERMOSTAT SUB-BASE REFER TO SYSTEM SCHEMATICS OR SCHEMATICS ON INDOOR SECTION FOR LOW VOLTAGE CONTROL WIRING. BLACK WIRE FROM SR (S) TO CC (T) DELETED WHEN PTCR IS USED. 	<p>ELECTRICAL WIRING DIAGRAM REMOTE AIR CONDITIONER SINGLE PHASE</p>	
<p>DWG. NO. 90-23238-01</p>	<p>REV 12</p>	<p>DR. BY MB</p>	<p>APP. BY JW</p>	<p>DATE 1-28-92</p>	<p>DWG. NO. 90-23238-01</p>

FIGURE 8
(-)AND THREE-PHASE UNITS WIRING DIAGRAM

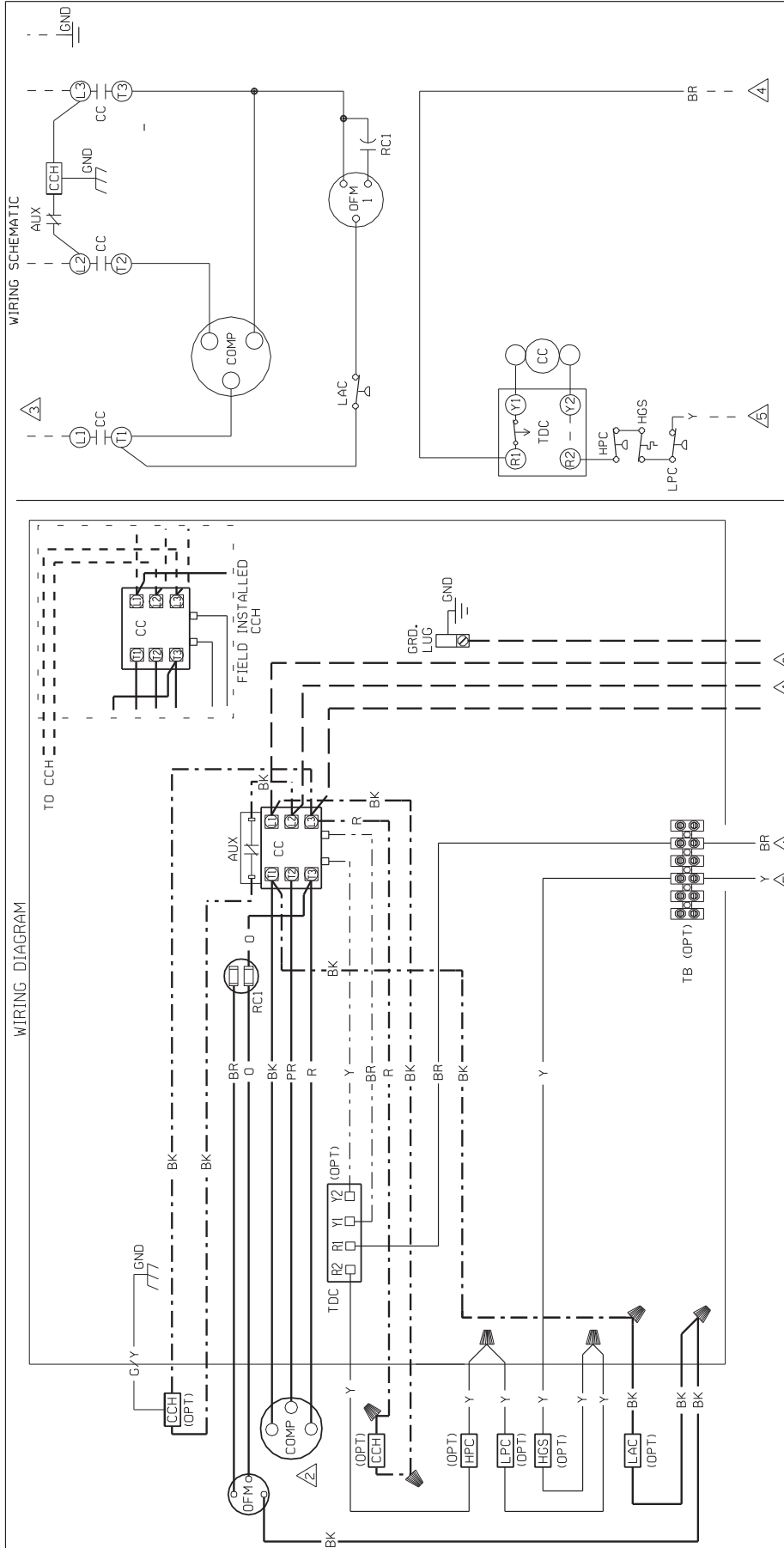

WIRING SCHEMATIC

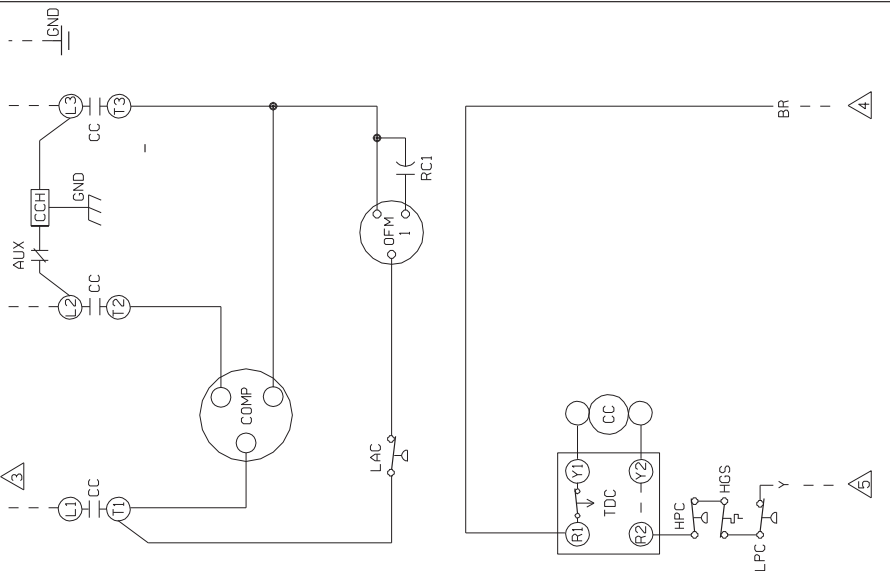

<p>COMPONENT CODE</p> <p>CC COMPRESSOR CONTACTOR CCH CRANKCASE HEATER COMP COMPRESSOR GND GROUND, CHASSIS HGS HOT GAS SENSOR LAC LOW AMBIENT TEMPERATURE CONTROL LPC LOW PRESSURE CONTROL OFM OPTIONAL FAN MOTOR OPT OPTIONAL RC RUN CAPACITOR RS START RELAY SR START RELAY TB TERMINAL BLOCK TDC TIME DELAY CONTROL</p>	<p>NOTES:</p> <ol style="list-style-type: none"> CONNECTORS SUITABLE FOR USE WITH COPPER CONDUCTORS ONLY. COMPRESSOR MOTOR THERMALLY PROTECTED AND ALL 3 PHASE ARE PROTECTED UNDER PRIMARY SINGLE PHASE CONDITIONS. CONNECT FIELD WIRING IN GROUNDED RAINTIGHT CONDUIT TO USE DISCONNECT, VOLTAGE, HERTZ AND PHASE PER RATING PLATE. LOW VOLTAGE CIRCUIT TO BE N.E.C. CLASS 2 WITH A CLASS 2 TRANSFORMER 24 VOLT, 50 OR 60 HERTZ. TO THERMOSTAT SUB-BASE REFER TO SYSTEM SCHEMATICS OR SCHEMATICS ON INDOOR SECTION FOR LOW VOLTAGE CONTROL WIRING. 	<p>WIRING INFORMATION</p> <p>LINE VOLTAGE -FACTORY STANDARD -FACTORY OPTION -FIELD INSTALLED LOW VOLTAGE -FACTORY STANDARD -FACTORY OPTION -FIELD INSTALLED REPLACEMENT WIRE</p> <p>*MUST BE THE SAME SIZE AND TYPE OF INSULATION AS ORIGINAL (105 C. MIN.) WARNING -CABINET MUST BE PERMANENTLY GROUNDED AND CONFORM TO I.E.C., N.E.C., C.E.C., NATIONAL WIRING REGULATIONS, AND LOCAL CODES AS APPLICABLE.</p>	<p>WIRE COLOR CODE</p> <p>BK BLACK BR BROWN BL BLUE G GREEN GY GRAY O ORANGE PR PURPLE R RED W WHITE Y YELLOW</p>	<p>ELECTRICAL WIRING DIAGRAM</p> <p>REMOTE AIR CONDITIONER THREE PHASE</p>	<p>DR. BY MCB APP. BY MCB DATE 9-19-05 DWG. NO. 90-101229-08 REV 01</p>
<p>DWG. NO. 90-101229-08</p>	<p>REV 01</p>	<p>REV 01</p>	<p>REV 01</p>	<p>REV 01</p>	<p>REV 01</p>

