

CEILING MOUNT AIR HANDLERS

INSTALLATION INSTRUCTIONS & OPERATING INSTRUCTIONS

© 2024 **DAIKIN COMFORT TECHNOLOGIES MANUFACTURING, L.P.**
19001 Kermier Rd., Waller, TX 77484
www.daikinac.com
P/N: IO-4015A Date: August 2024

FRONT RETURN CONFIGURATION

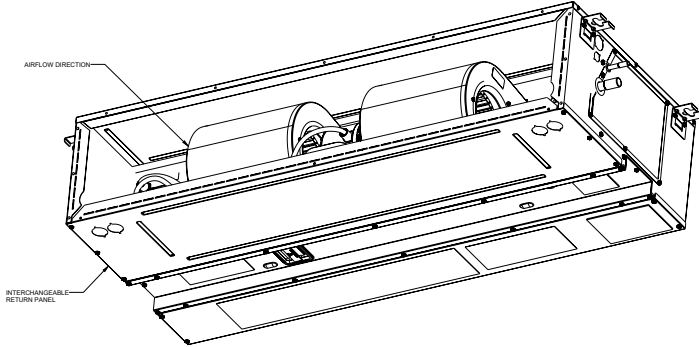

BOTTOM RETURN CONFIGURATION

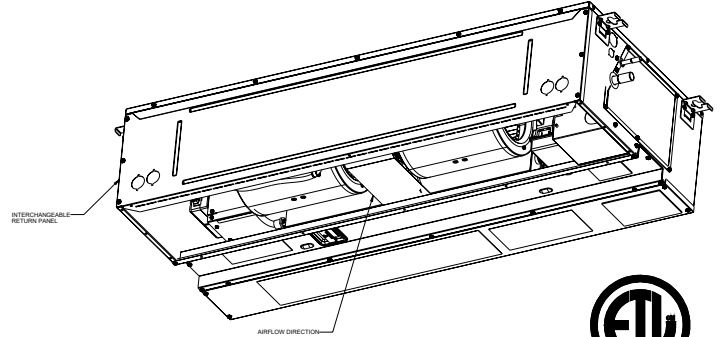

WARNING

ONLY PERSONNEL THAT HAVE BEEN TRAINED TO INSTALL, ADJUST, SERVICE, MAINTENANCE OR REPAIR (HEREINAFTER, "SERVICE") THE EQUIPMENT SPECIFIED IN THIS MANUAL SHOULD SERVICE THE EQUIPMENT.

THIS EQUIPMENT IS NOT INTENDED FOR USE BY PERSONS (INCLUDING CHILDREN) WITH REDUCED PHYSICAL, SENSORY OR MENTAL CAPABILITIES, OR LACK OF EXPERIENCE AND KNOWLEDGE, UNLESS THEY HAVE BEEN GIVEN SUPERVISION OR INSTRUCTION CONCERNING USE OF THE APPLIANCE BY A PERSON RESPONSIBLE FOR THEIR SAFETY.

CHILDREN SHOULD BE SUPERVISED TO ENSURE THAT THEY DO NOT PLAY WITH THE EQUIPMENT.

THE MANUFACTURER WILL NOT BE RESPONSIBLE FOR ANY INJURY OR PROPERTY DAMAGE ARISING FROM IMPROPER SUPERVISION, SERVICE OR SERVICE PROCEDURES. IF YOU SERVICE THIS UNIT, YOU ASSUME RESPONSIBILITY FOR ANY INJURY OR PROPERTY DAMAGE WHICH MAY RESULT. IN ADDITION, IN JURISDICTIONS THAT REQUIRE ONE OR MORE LICENSES TO SERVICE THE EQUIPMENT SPECIFIED IN THIS MANUAL, ONLY LICENSED PERSONNEL SHOULD SERVICE THE EQUIPMENT. IMPROPER SUPERVISION, INSTALLATION, ADJUSTMENT, SERVICING, MAINTENANCE OR REPAIR OF THE EQUIPMENT SPECIFIED IN THIS MANUAL, OR ATTEMPTING TO INSTALL, ADJUST, SERVICE OR REPAIR THE EQUIPMENT SPECIFIED IN THIS MANUAL WITHOUT PROPER SUPERVISION OR TRAINING MAY RESULT IN PRODUCT DAMAGE, PROPERTY DAMAGE, PERSONAL INJURY OR DEATH.

WARNING

DO NOT BYPASS SAFETY DEVICES

WARNING

HIGH VOLTAGE

DISCONNECT ALL POWER BEFORE SERVICING OR INSTALLING THIS UNIT. MULTIPLE POWER SOURCES MAY BE PRESENT. FAILURE TO DO SO MAY CAUSE PROPERTY DAMAGE, PERSONAL INJURY OR DEATH.



RECOGNIZE THIS SYMBOL AS A SAFETY PRECAUTION.

NOTE: SPECIFICATIONS AND PERFORMANCE DATA LISTED HEREIN ARE SUBJECT TO CHANGE WITHOUT NOTICE.

NOTE: NEVER OPERATE THE UNIT WITHOUT ALL PANELS INSTALLED.

NOTE: THIS EQUIPMENT IS APPROVED TO USE ONLY WITH R-32 REFRIGERANT



CONTENTS

1 Important Safety Instructions	4
2 Codes & Regulations	4
3 Shipping Inspection	4
3.1 Parts	4
3.2 Handling	4
3.3 Shipping Material Removal.....	4
4 Wiring Diagram	5
5 Replacement Parts	6
6 Application Information	6
7 Pre-Installation Instructions	6
7.1 Preparation	6
7.2 System Matches	6
7.3 Installation Clearances	6
7.4 Ducting	6
7.5 Filters	6
7.6 Condensate Drain Piping.....	6
8 Layout for Ceiling Mount Air Handler	7
9 Electrical Connections	8
9.1 Wiring	8
9.2 Wire Sizing	8
10 Maximum Overcurrent Protection (MOP)	9
10.1 Internal Wiring	9
10.2 High Voltage Wiring	9
10.3 Low Voltage Wiring.....	9
11 Constant Torque (EEM) Motors	10
12 Airflow Data	11
13 Refrigerant Lines	11
13.1 Tubing Size.....	11
13.2 Tubing Connections.....	11
13.3 Standing Pressure Test (Recommended before vacuum).....	12
13.4 Deep Vacuum Method.....	12
13.5 Detection of Refrigerant.....	12
13.6 Removal and Evacuation	12
13.7 Refrigerant Recovery.....	12
13.8 Thermal Expansion Valve System Adjustment.....	13
14 Refrigeration Detection System (RDS)	15
14.1 Altitude Adjustment Factor to Calculate Minimum Room Area.....	16
14.2 Sensor Mounting and Dismounting Instructions	17
14.3 R-32 PCB Mounting and Dismounting Instructions	17
15 Maintenance	19
15.1 Room Thermostat.....	19
15.2 Fuses and/or Circuit Breakers	19
15.3 Periodic Checkup and Service	19
15.4 Heater Kit Service.....	19



WARNING

DO NOT USE MEANS TO ACCELERATE THE DEFROSTING PROCESS OR TO CLEAN, OTHER THAN THOSE RECOMMENDED BY THE MANUFACTURER. THE APPLIANCE SHALL BE STORED IN A ROOM WITHOUT CONTINUOUSLY OPERATING IGNITION SOURCES (FOR EXAMPLE: OPEN FLAMES, AN OPERATING GAS APPLIANCE OR AN OPERATING ELECTRIC HEATER). DO NOT PIERCE OR BURN. BE AWARE THAT REFRIGERANTS MAY NOT CONTAIN AN ODOR.



WARNING

TO PREVENT THE RISK OF PROPERTY DAMAGE, PERSONAL INJURY, OR DEATH, DO NOT STORE COMBUSTIBLE MATERIALS OR USE GASOLINE OR OTHER FLAMABLE LIQUIDS OR VAPORS IN THE VICINITY OF THIS APPLIANCE.



WARNING

A REFRIGERANT LEAK DETECTION SYSTEM IS INSTALLED. THE UNIT MUST BE POWERED ON AT ALL TIMES EXCEPT FOR SERVICE.



WARNING

THIS UNIT SHOULD NOT BE CONNECTED TO, OR USED IN CONJUNCTION WITH, ANY DEVICES THAT ARE NOT DESIGN CERTIFIED FOR USE WITH THIS UNIT OR HAVE NOT BEEN TESTED AND APPROVED BY THE MANUFACTURER. SERIOUS PROPERTY DAMAGE OR PERSONAL INJURY, REDUCED UNIT PERFORMANCE AND/OR HAZARDOUS CONDITIONS MAY RESULT FROM THE USE OF DEVICES THAT HAVE NOT BEEN APPROVED OR CERTIFIED BY THE MANUFACTURER.



WARNING

PARTIAL UNITS SHALL ONLY BE CONNECTED TO AN APPLIANCE SUITABLE FOR THE SAME REFRIGERANT. THIS UNIT IS A PARTIAL UNIT AIR CONDITIONER, COMPLYING WITH PARTIAL UNIT REQUIREMENTS OF THIS INTERNATIONAL STANDARD, AND MUST ONLY BE CONNECTED TO OTHER UNITS THAT HAVE BEEN CONFIRMED AS COMPLYING TO CORRESPONDING PARTIAL UNIT REQUIREMENTS OF THIS INTERNATIONAL STANDARD.



WARNING

ALL ACCESSORIES THAT MAY BECOME A POTENTIAL IGNITION SOURCE IF INSTALLED, SUCH AS ELECTRONIC AIR CLEANERS, MUST ONLY BE POWERED THROUGH OUR ACCESSORY CONTROL BOARD KIT. IF AN ELECTRONIC AIR CLEANER IS ALREADY INSTALLED IN THE DUCT WORK AND NOT CONNECTED TO THE ACCESSORY CONTROL BOARD, IT WILL HAVE TO BE DISABLED OR REMOVED. ENSURE THAT ANY ADDITIONAL WIRING FROM THE INDOOR UNIT TO THE ACCESSORY CONTROL BOARD IS ROUTED AND PROTECTED FROM DAMAGE AND WEAR, AVOIDING THE FLUE PIPE AND ANY JOINTS THAT MAY NEED BRAZED OR DISCONNECTED FOR SERVICE. REFER TO THE PRODUCT SPECIFICATION SHEET FOR THE ACCESSORY CONTROL BOARD KIT PART NUMBER.



WARNING

IF ANY HOT WORK IS TO BE CONDUCTED ON THE REFRIGERATING EQUIPMENT OR ANY ASSOCIATED PARTS, APPROPRIATE FIRE EXTINGUISHING EQUIPMENT SHALL BE AVAILABLE ON HAND. HAVE A DRY POWDER OR CO₂ FIRE EXTINGUISHER ADJACENT TO THE HOT WORK AREA. ENSURE THAT THE AREA IS IN THE OPEN OR THAT IT IS ADEQUATELY VENTILATED BEFORE BREAKING INTO THE SYSTEM OR CONDUCTING ANY HOT WORK. A DEGREE OF VENTILATION SHALL CONTINUE DURING THE PERIOD THAT THE WORK IS CARRIED OUT. THE VENTILATION SHOULD SAFELY DISPERSE ANY RELEASED REFRIGERANT AND PREFERABLY EXPEL IT EXTERNALLY INTO THE ATMOSPHERE.



WARNING

AUXILIARY DEVICES WHICH MAY BE A POTENTIAL IGNITION SOURCE ARE NOT TO BE INSTALLED IN THE DUCT WORK. SUCH POTENTIAL IGNITION SOURCES INCLUDE HOT SURFACES WITH A TEMPERATURE EXCEEDING 650°C AND ELECTRIC SWITCHING DEVICES. FOR EXAMPLE, ELECTRONIC AIR FILTERS ARE A POTENTIAL IGNITION SOURCE.



CAUTION

THIS APPLIANCE IS NOT INTENDED FOR THE USE BY PERSONS (INCLUDING CHILDREN) WITH THE REDUCED PHYSICAL, SENSORY OR MENTAL CAPABILITIES, OR LACK OF EXPERIENCE AND KNOWLEDGE, UNLESS THEY HAVE BEEN GIVEN SUPERVISION OR INSTRUCTION CONCERNING USE OF THE APPLIANCE BY A PERSON RESPONSIBLE FOR THEIR SAFETY. CHILDREN SHOULD BE SUPERVISED TO ENSURE THAT THEY DO NOT PLAY WITH THE APPLIANCE.



CAUTION

HAVE YOUR CONTRACTOR IDENTIFY ALL THE VARIOUS CUT OFF SWITCHES AND DEVICES THAT SERVICE THIS UNIT. KNOW WHERE THE SWITCH IS THAT WILL CUT OFF ENERGY TO THE HEATING SYSTEM IN THE EVENT OF OVERHEATING.



WARNING

WHEN INSTALLED IN A ROOM WITH AN AREA LESS THAN THAT OUTLINED IN TABLE 5, THAT ROOM SHALL BE WITHOUT CONTINUOUSLY OPERATING OPEN FLAMES (FOR EXAMPLE AN OPERATING GAS APPLIANCE) OR OTHER POTENTIAL IGNITION SOURCES (FOR EXAMPLE AN OPERATING ELECTRIC HEATER, HOT SURFACES).



WARNING

APPLIANCE NOT ACCESSIBLE TO THE GENERAL PUBLIC. CHECK SERIAL PLATE FOR MAXIMUM OPERATING CONDITIONS.



DANGER
PELIGRO

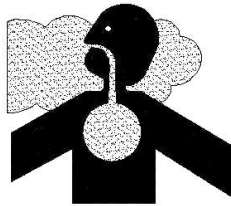

CARBON MONOXIDE POISONING HAZARD

Special Warning for Installation of Furnace or Air Handling Units in Enclosed Areas such as Garages, Utility Rooms or Parking Areas

Carbon monoxide producing devices (such as automobiles, space heater, gas water heater, etc.) should not be operated in enclosed areas such as unventilated garages, utility rooms or parking areas because of the danger of carbon monoxide (CO) poisoning resulting from the exhaust emissions. If a furnace or air handler is installed in an enclosed area such as a garage, utility room or parking area and a carbon monoxide producing device is operated therein, there must be adequate, direct outside ventilation.

This ventilation is necessary to avoid the danger of CO poisoning which can occur if a carbon monoxide producing device continues to operate in the enclosed area. Carbon monoxide emissions can be (re)circulated throughout the structure if the furnace or air handler is operating in any mode.

CO can cause serious illness including permanent brain damage or death.

B10259-216

RIESGO DE INTOXICACIÓN POR MONÓXIDO DE CARBONO

Advertencia especial para la instalación de calentadores ó manejadoras de aire en áreas cerradas como estacionamientos ó cuartos de servicio.

Los equipos ó aparatos que producen monóxido de carbono (tal como automóvil, calentador de gas, calentador de agua por medio de gas, etc) no deben ser operados en áreas cerradas debido al riesgo de envenenamiento por monóxido de carbono (CO) que resulta de las emisiones de gases de combustión. Si el equipo ó aparato se opera en dichas áreas, debe existir una adecuada ventilación directa al exterior.

Esta ventilación es necesaria para evitar el peligro de envenenamiento por CO, que puede ocurrir si un dispositivo que produce monóxido de carbono sigue operando en el lugar cerrado.

Las emisiones de monóxido de carbono pueden circular a través del aparato cuando se opera en cualquier modo.

El monóxido de carbono puede causar enfermedades severas como daño cerebral permanente ó muerte.

B10259-216

RISQUE D'EMPOISONNEMENT AU MONOXYDE DE CARBONE

Avertissement special au sujet de l'installation d'appareils de chauffage ou de traitement d'air dans des endroits clos, tels les garages, les locaux d'entretien et les stationnements.

Evitez de mettre en marche les appareils produisant du monoxyde de carbone (tels que les automobile, les appareils de chauffage autonome, etc.) dans des endroits non ventilés tels que les d'empoisonnement au monoxyde de carbone. Si vous devez faire fonctionner ces appareils dans un endroit clos, assurez-vous qu'il y ait une ventilation directe provenant de l'exterieur.

Cette ventilation est nécessaire pour éviter le danger d'intoxication au CO pouvant survenir si un appareil produisant du monoxyde de carbone continue de fonctionner au sein de la zone confinée.

Les émissions de monoxyde de carbone peuvent être recirculées dans les endroits clos, si l'appareil de chauffage ou de traitement d'air sont en marche.

Le monoxyde de carbone peut causer des maladies graves telles que des dommages permanents au cerveau et même la mort.

B10259-216

1 IMPORTANT SAFETY INSTRUCTIONS

Symbols and labels are used throughout this manual to indicate immediate or potential safety hazards. The owner's and installer's responsibility is to read and comply with all safety information and instructions accompanying these symbols. Failure to heed safety information increases the risk of personal injury, property damage, and/or product damage.

NOTE: THIS UNIT SHOULD BE INSTALLED IN A MANNER SO THAT IT IS NOT ACCESSIBLE TO THE GENERAL PUBLIC.

2 CODES & REGULATIONS

This product is designed and manufactured to comply with national codes such as ASHRAE 15, ASHRAE 15.2, IAPMO Uniform Mechanical Code, ICC International Mechanical Code, or CSA B52. Installation in accordance with such codes and/or prevailing local codes/regulations is the responsibility of the installer. The manufacturer assumes no responsibility for equipment installed in violation of any codes or regulations. The standard test ambient operating conditions for cooling and heating modes are 80°F and 70°F, respectively.

The United States Environmental Protection Agency (EPA) has issued various regulations regarding the introduction and disposal of refrigerants. Failure to follow these regulations may harm the environment and can lead to the imposition of substantial fines.

These regulations may vary by jurisdiction. A certified technician must perform the installation and service of this product. Should you have any questions please contact the local office of the EPA and/or refer to the EPA's website www.epa.gov.

3 SHIPPING INSPECTION

Upon receiving the product, inspect it for damage from shipment. Shipping damage and subsequent investigation are the responsibility of the carrier. Verify the model number, specifications, electrical characteristics, and accessories are correct before installation. The distributor or manufacturer will not accept claims from dealers for transportation damage or installation of incorrectly shipped units.

3.1 Parts

Inspect the unit to verify all required components are present and intact. Report any missing components immediately to the manufacturer or the distributor. Use only factory-authorized replacement parts. Make sure to include the full product model number and serial number when reporting and/or obtaining service parts.

3.2 Handling

Use caution when transporting/carrying the unit. Do not move the unit using shipping straps. Do not carry units with hooks or sharp objects. The preferred method of carrying the unit after arrival at the job site is to carry it via a two-wheel hand truck. Take proper precautions when carrying the unit to avoid damage to the piping.

3.3 Shipping Material Removal

IMPORTANT: All Shipping Material used to protect the equipment, and the equipment's components, during transit, should be removed before the final installation.

4 WIRING DIAGRAM



WARNING
HIGH VOLTAGE!
 DISCONNECT ALL POWER BEFORE SERVICING OR INSTALLING THIS UNIT.
 MULTIPLE POWER SOURCES MAY BE PRESENT. FAILURE TO DO SO MAY
 CAUSE PROPERTY DAMAGE, PERSONAL INJURY OR DEATH.

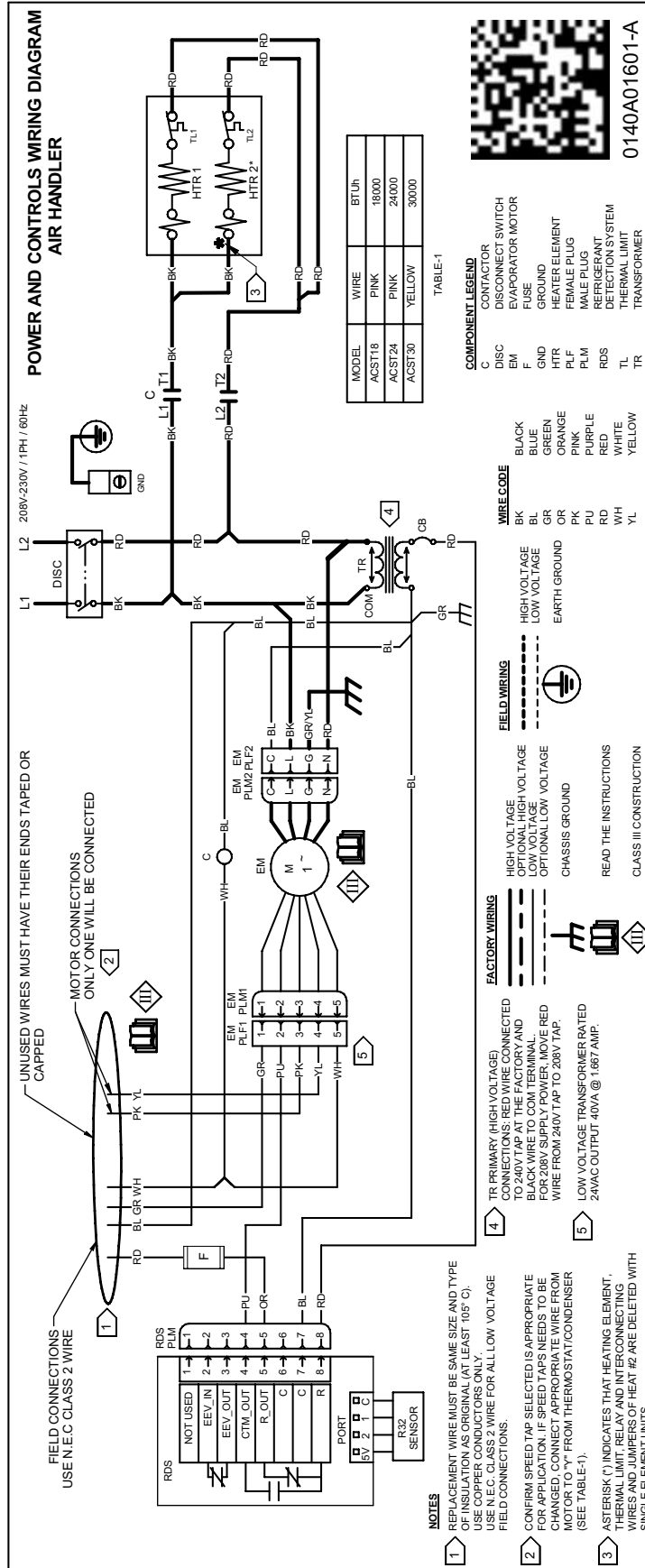

Wiring is subject to change. Always refer to the Wiring Diagram on the unit for the most up-to-date wiring.

5 REPLACEMENT PARTS

When reporting shortages or damages, or ordering repair parts, give the complete product model and serial numbers as stamped on the product. Replacement parts for this product are available through your contractor or local distributor. Your nearest distributor can be located online at <https://partner.goodmanmfg.com/> or by contacting:

HOMEOWNER SUPPORT
DAIKIN COMFORT TECHNOLOGIES MANUFACTURING, L.P.
19001 KERMIER ROAD,
WALLER, TX 77484
855-770-5678

6 APPLICATION INFORMATION



CAUTION

HEAT PUMP PREMATURE FAILURE NOTICE
RUNNING THE UNIT WITHOUT HPSK-1 KIT INSTALLED ON
THE HEAT PUMP CAN CAUSE PREMATURE UNIT FAILURE. AN
HPSK-1 KIT MUST BE INSTALLED ON ALL HEAT PUMP APPLI-
CATIONS.

This ceiling mount air handler is available in cooling capacities of 1.5, 2.0, and 2.5 nominal tons of cooling with a constant torque (EEM) motor. Electric heat models are available in capacities of 5, 6, 8, and 10 kW.

The unit is designed to be installed only in a horizontal position above a dropped ceiling. Do NOT install this unit outside the structure. These models are designed for INDOOR USE ONLY.

7 PRE-INSTALLATION INSTRUCTIONS

Carefully read all instructions for the installation before installing the product. Make sure each step or procedure is understood and any special considerations are taken into account before starting installation. Assemble all tools, hardware, and supplies needed to complete the installation. Some items may need to be purchased locally. Make sure everything needed to install the product is on hand before starting.

Before attempting any installation, the following points should be considered:

- Structural strength of supporting members
- Clearances and provision for servicing
- Power supply and wiring
- Air duct connections
- Drain facilities and connections

7.1 Preparation

Keep this document with the unit. Carefully read all instructions for the installation before installing the product. Make sure each step or procedure is understood and any special considerations are taken into account before starting installation. Assemble all tools, hardware, and supplies needed to complete the installation. Some items may need to be purchased locally. Make sure everything needed to install the product is on hand before starting.

7.2 System Matches

The entire system (combination of indoor and outdoor sections) must be approved by the manufacturer and Air-conditioning, Heating, and Refrigeration Institute (AHRI) listed.

7.3 Installation Clearances

Place this unit as close to the space to be air-conditioned as possible. These units are U.L. listed for installations with zero clearance to combustible materials. If this unit is installed in a removable ceiling panel, ensure adequate space is available for servicing. Ensure that there is at least 24 inches of clearance from the access panel to service the TXV and the R-32 sensor. Run ducts as directly as possible to supply and return outlets. Use non-flammable weatherproof flexible connectors on both supply and return connections at the unit to reduce noise transmission.

7.4 Ducting

Ductwork should be fabricated by the installing contractor in accordance with local codes. Use industry manuals such as NESCA (National Environmental Systems Contractors Association, 1501 Wilson Blvd., Arlington, Virginia 22209) as a guide when sizing and designing the duct system.

To ensure correct system performance, the ductwork is to be sized to accommodate 375-425 CFM per ton of cooling with the static pressure not to exceed 0.3" W.C. Inadequate ductwork that restricts airflow can result in improper performance and compressor or heater failure.



WARNING

TO PREVENT POSSIBLE EQUIPMENT DAMAGE, PROPERTY
DAMAGE, FIRE, CARBON MONOXIDE POISONING, EXPLOSION,
PERSONAL INJURY, OR DEATH, DO NOT CONNECT DUCTWORK
TO ANY HEAT-PRODUCING DEVICE SUCH AS A FIREPLACE
INSERT OR STOVE.

7.5 Filters

Filters are not provided with a unit and must be supplied and installed in the return air system by the installer. A field-installed filter grille is recommended for easy and convenient access to the filters for periodic inspection and cleaning. Filters must have adequate face area for the rated air quantity of the unit. The minimum filter size is 20" x 20" x 1".

7.6 Condensate Drain Piping

The coil drain pan has a primary and a secondary drain with 3/4" NPT female connections. The connectors required are 3/4" NPT male, either PVC or metal pipe and should be hand tightened to a torque of no more than 37 in-lbs. to prevent damage to the drain pan connection. An insertion depth between .143 to .355 inches (2-5 turns) should be expected at this torque. Use the female (3/4 NPT) threaded fitting that protrudes outside of the enclosure for external connections.

1. Ensure the drain pan hole is NOT obstructed.
2. To prevent potential sweating and dripping onto the finished space, it may be necessary to insulate the condensate drain line located inside the building. Use Armaflex® or similar material.

A Secondary Condensate Drain Connection has been provided for areas where the building codes require it. Pitch the drain line 1/4" per foot to provide free drainage. Insulate drain lines located inside the building to prevent sweating. Install a condensate trap to ensure proper drainage. If the secondary drain line is required, run the line separately from the primary drain and end it where it can be easily seen.

NOTE: Water coming from this line means the coil primary drain is plugged and needs clearing.

 CAUTION
IF SECONDARY DRAIN IS NOT INSTALLED, THE SECONDARY ACCESS MUST BE PLUGGED.

The installation must include a "P" style trap that is located as close as is practical to the evaporator coil. See **Figure 1** for details of a typical condensate line "P" trap.

NOTE: Trapped lines are required by many local codes. In the absence of any prevailing local codes, please refer to the requirements listed in the Uniform Mechanical Building Code.

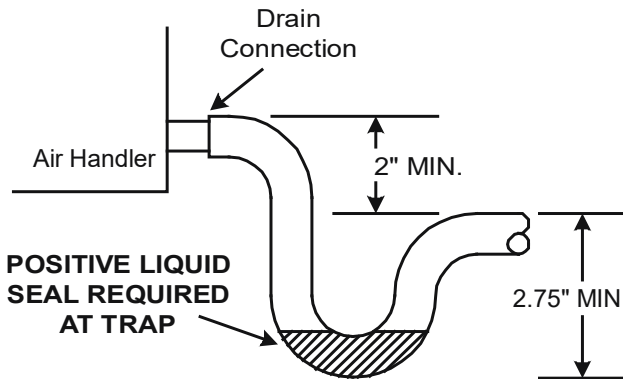

Figure 1

In a **blow-through** application the drain trap prevents conditioned air from escaping. It is permissible in this application to use a shallow trap design sometimes referred to as a running trap.

The depth of a running trap (Figure 2) should be either 1" or a depth that permits unrestricted condensate drainage without excessive air discharge.

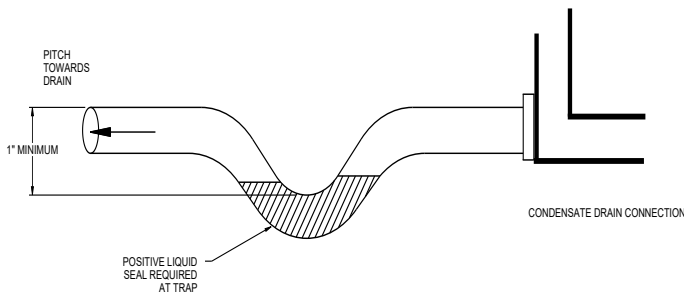

Figure 2

Field experience has shown condensate drain traps with an open vertical Tee between the air handler and the condensate drain trap can improve condensate drainage in some applications, but may cause excessive air discharge out of the open Tee. We do not prohibit this type of drain but we also do not recommend it due to the resulting air leakage. Regardless of the condensate drain design used, it is the installer's responsibility to ensure the condensate drain system is of sufficient design to ensure proper condensate removal from the coil drain pan.

When coils are installed above ceilings, or in other locations where damage from condensate overflow may occur, it is **MANDATORY** to install a field fabricated auxiliary drain pan under the coil cabinet enclosure. Drain lines from the auxiliary pan must be installed and terminated so that the homeowner can see water discharges. A primary condensate drain connection is located in the drain pan on the bottom of the coil / enclosure assembly. The female (3/4 NPT) threaded fitting that protrudes outside of the enclosure is used for external connections.

8 LAYOUT FOR CEILING MOUNT AIR HANDLERS

NOTE: These air handlers are designed for indoor installation only at a max altitude of 10,500 feet above sea level or a min altitude of -184 feet below sea level.

If the unit is located in an unconditioned area with high ambient temperature and/or high humidity, the air handler may be subject to nuisance sweating of the casing. On these installations, a wrap of 2" fiberglass insulation with a vapor barrier is recommended. A secondary drain pan below the unit is also recommended to protect the installation site.

1. Before locating the unit on the dropped ceiling, ensure the strength of the ceiling and beams is adequate to support the weight involved. This is an important step and the installers responsibility. See the table below for approximate weight of unit.

MODEL	WEIGHT (lbs)
1.5 TON	85.0
2.0 TON	97.0
2.5 TON	97.0

Table 1

2. Mount the unit in a horizontal position above a dropped ceiling of adequate strength. Refer to Figure 3. Refer to Figure 4 for proper mounting methods.

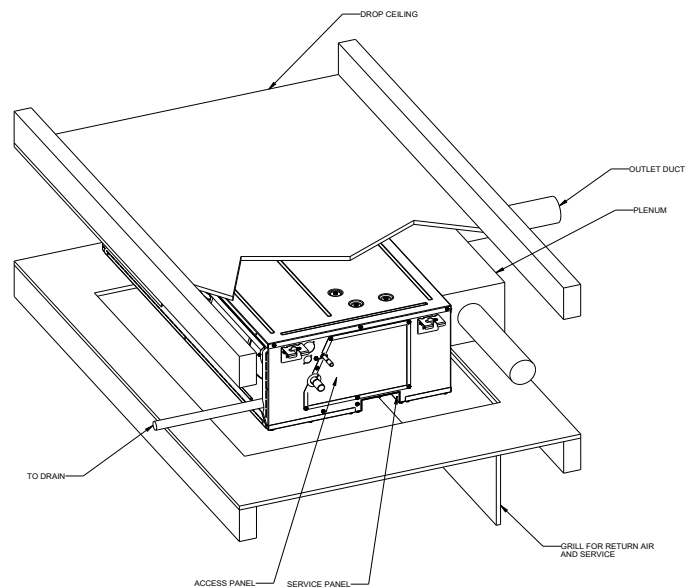

Figure 3

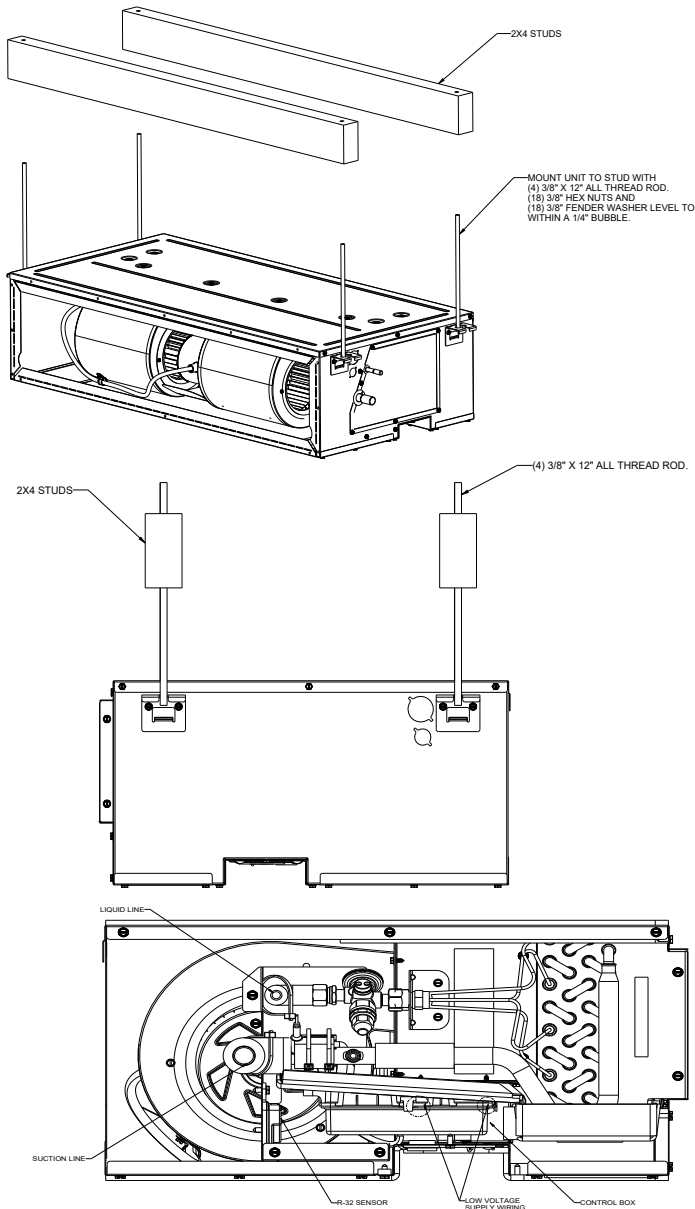

Figure 4

3. The location of the unit should provide proper access for inspection and servicing.

MODEL	A	B	C	D
1.5 TON	48 1/5	45 7/16	36 1/5	6 1/2
2.0 TON	54 1/5	51 7/16	42 1/5	6 1/2
2.5 TON	54 1/5	51 7/16	42 1/5	6 1/2

Table 2

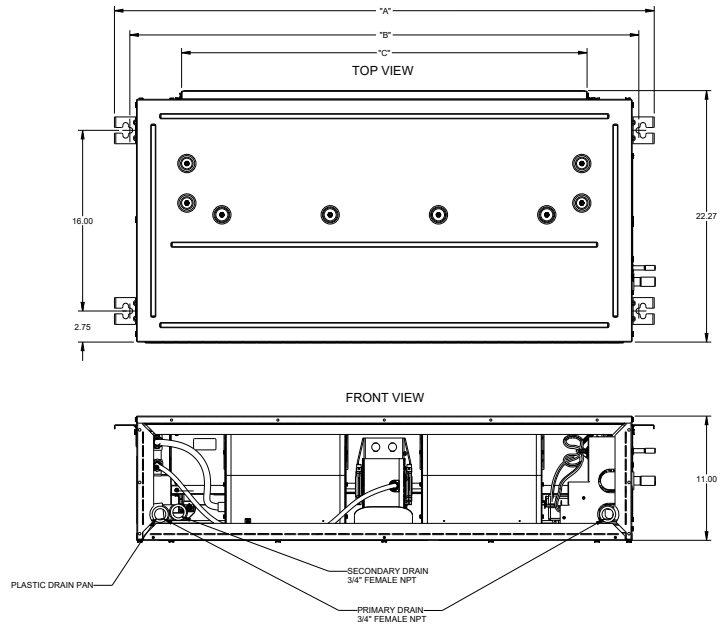

Figure 5

IMPORTANT: Installation of Air Handler must follow any local codes/regulations. The manufacturer recommends that when a heater kit is not installed, a field-supplied disconnect switch or breaker should be installed in the electrical circuit that will allow power to be shut off for service or maintenance.

9 ELECTRICAL CONNECTIONS

WARNING

HIGH VOLTAGE
TO AVOID THE RISK OF FIRE OR EQUIPMENT DAMAGE, USE ONLY COPPER CONDUCTORS. DISCONNECT ALL POWER BEFORE SERVICING OR INSTALLING THIS UNIT. MULTIPLE POWER SOURCES MAYBE PRESENT. THE ELECTRICAL POWER TO THIS UNIT MUST BE IN THE OFF POSITION AND ALL POWER SUPPLIES DISCONNECTED. FAILURE TO DO SO MAY CAUSE PROPERTY DAMAGE, PERSONAL INJURY OR DEATH.

9.1 Wiring

Check that cabling will not be subject to wear, corrosion, excessive pressure, vibration, sharp edges or any other adverse environmental effects. The check shall also take into account the effects of aging or continual vibration from sources such as compressors or fans.

9.2 Wire Sizing

Wire size is important to the operation of your equipment. Use the following check list when selecting the appropriate wire size for your unit.

Wire used must carry the Minimum Circuit Ampacity (MCA) listed on the unit's Series and Rating Plate.

Refer to the NEC (USA) or CSA (Canada) for wire sizing. The unit MCA for the air handler and the optional electric heat kit can be found on the unit Series and Rating Plate.

The wire must be sized to allow no more than a 2% voltage drop from the building breaker/fuse panel to the unit.

Wires with different insulation temperature ratings have varying ampacities - be sure to check the temperature rating used.

Refer to the latest edition of the National Electric Code or in Canada the Canadian Electric Code when determining the correct wire size.

Determine the availability of sufficient power to operate the unit. The voltage at the power supply must correspond to the unit's RATED VOLTAGE REQUIREMENT.

Determine wire sizes from the unit nameplate ampacity and in accordance with the National Electrical Code. The wiring should never be sized smaller than is recommended by either of these two sources.

The unit must be permanently grounded in accordance with local codes, or in the absence of local codes, with the N.E.C. ANSI/NFPA NO. 70-2023 or the latest edition in the U.S.A.

10 MAXIMUM OVERCURRENT PROTECTION (MOP)

Every installation must include an NEC (USA) or CEC (Canada) approved overcurrent protection device. Also, check with local or state codes for any special regional requirements.

Protection can be in the form of fusing or HACR-style circuit breakers. The Series and Rating Plate can be used as a guide for selecting the MAXIMUM overcurrent device.

NOTE: Fuses or circuit breakers are to be sized larger than the equipment MCA but not to exceed the MOP.

10.1 Internal Wiring

A diagram of the internal wiring of this unit is located on the bottom panel. If any of the original wires supplied with the appliance must be replaced, the wire gauge and insulation must be the same as the original wiring.

The Transformer is factory wired for 230 volts on 208/ 230 volt models. See the wiring diagram for 208 volt wiring. For 208V operation, move the red wire lead from 240V to 208V tap.

Make the following high and low voltage connections at either location to wire units.

10.2 High Voltage Wiring

This unit is designed for Single phase 208/230 Volt only. Connect the two leads to terminals L1 and L2 on the disconnect (Refer to figure 6) and field ground wire to the ground lug in the electrical control section, using wire sizes specified in the wire sizing section.

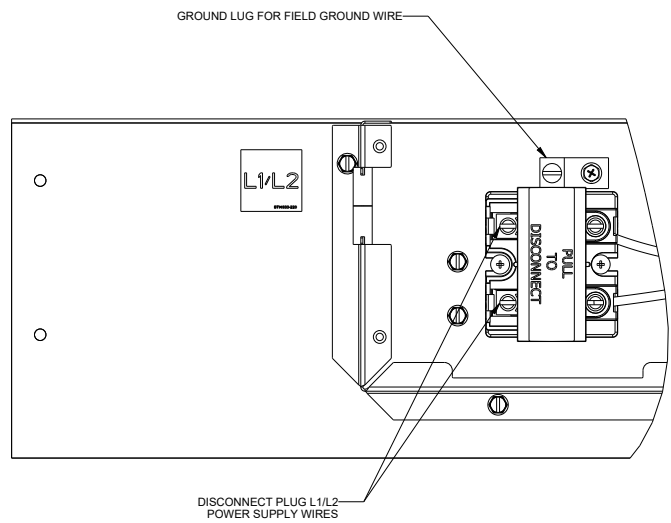

Figure 6

10.3 Low Voltage Wiring

Refer to Figure 7 for the cooling unit with electric heat and refer to Figure 8 for the heat pump with electric heat.

NOTE: HPSK-01 Heat Pump Shut-Off Relay Kit (C.R.I.) must be used when ACST with electric heat is installed with a heat pump.

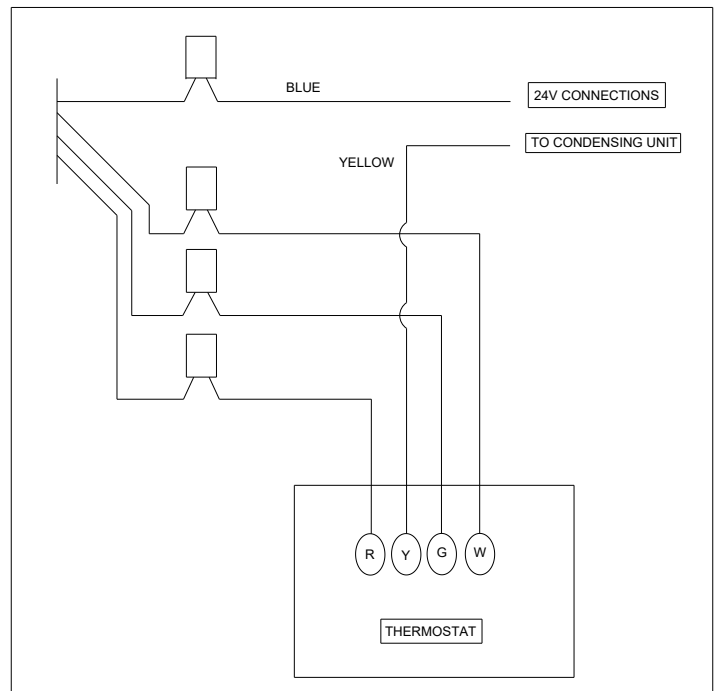

Figure 7

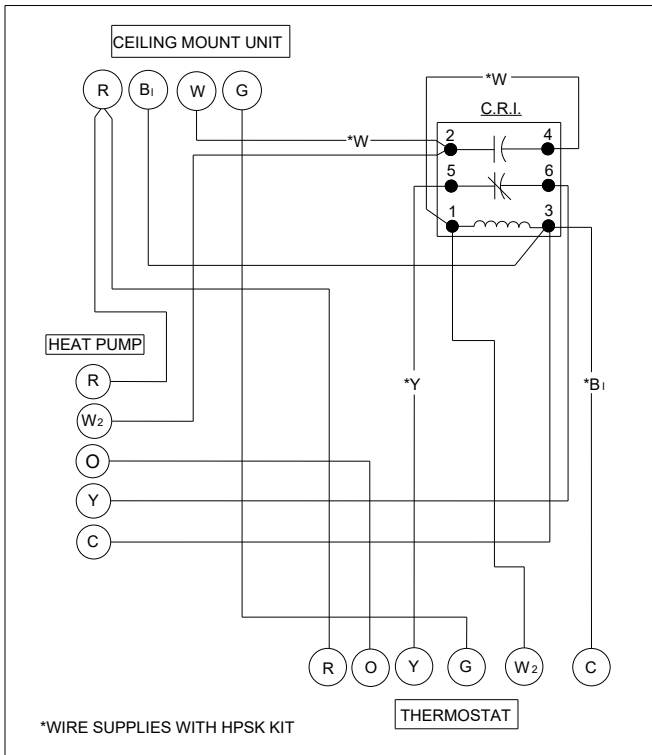

Figure 8

11 CONSTANT TORQUE (EEM) MOTORS

ACST models utilize constant torque (EEM) motors. These motors come with a separate control box which is mounted on the side of the unit as shown in Figure 9. The harness from the motor is inserted into the control box which has another harness leading into the control panel of the unit.

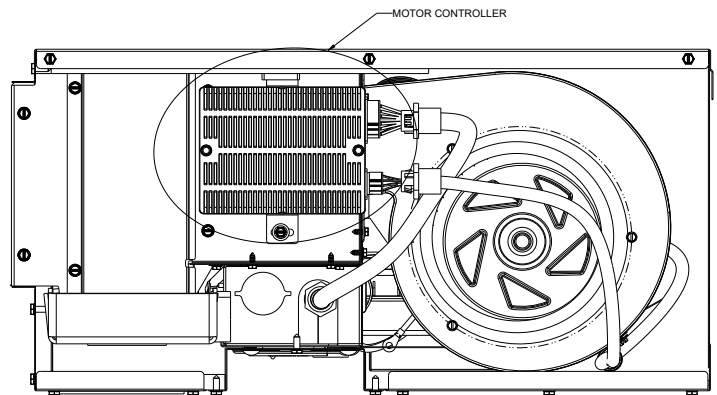

Figure 9

The high voltage wiring is the same as the other ACST models.

The low voltage wiring connections are shown in Figure 10. The wire from the motor, T3 (pink) or T4 (yellow), connects to "Y" from the thermostat/condenser depending on the application.

Connect low voltage wires from the thermostat to the corresponding wires in the Ceiling Mount unit and outdoor unit using No. 18 AWG wires as follows:

LEAD	THERMOSTAT	NOTES
RED	R (24V)	-
GREEN	G (FAN)	-
-	Y	TO CONDENSING UNIT 24V CONNECTIONS
WHITE	W	-
BLUE	-	TO CONDENSING UNIT 24V CONNECTIONS

Table 3

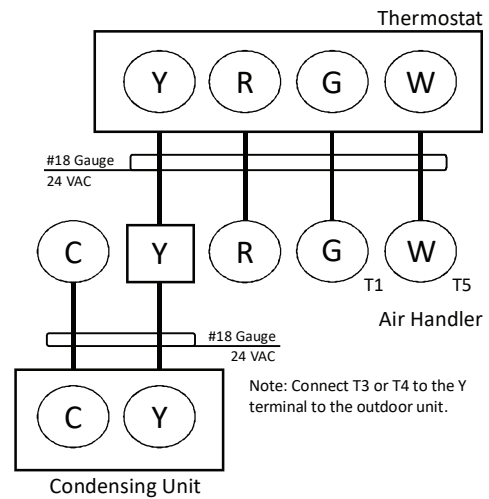

CONFIRM SPEED TAP SELECTED (T3 OR T4)
IS APPROPRIATE FOR THE APPLICATION BASED ON THIS TABLE.

MODEL	WIRE	BTUh
ACST18	PINK	18000
ACST24	PINK	24000
ACST30	YELLOW	30000

Figure 10

12 AIRFLOW DATA

Model	Speed Tap	CFM @ STATIC PRESSURE (IN W.C.)		
		0.1	0.2	0.3
ACST18MU13**AA	T1	631	583	538
	T2	631	583	538
	T3	694	645	601
	T4	831	776	729
	T5	831	776	729
ACST24LU13**AA ACST30LU13**AA	T1	829	766	721
	T2	829	766	721
	T3	869	820	773
	T4	934	883	840
	T5	934	883	840

Table 4

NOTE:

1. Airflow data indicated is at 230V without an air filter in place.
2. The cooling/heating speed tap should be selected based on AHRI Ratings. Otherwise, select a speed tap that provides a minimum of 300 CFM per outdoor ton. For satisfactory operation, external static pressure must not exceed 0.3" WC (for electric heaters only).

13 REFRIGERANT LINES:

 WARNING
<p>ONLY BRAZING TECHNIQUES AND APPROVED MECHANICAL JOINTS SHOULD BE USED TO CONNECT REFRIGERANT TUBING CONNECTIONS. NON-APPROVED MECHANICAL CONNECTORS AND OTHER METHODS ARE NOT PERMITTED IN THIS SYSTEM CONTAINING R-32 REFRIGERANT. APPROVED MECHANICAL JOINTS WILL BE DETAILED IN THE PRODUCT'S SPECIFICATION SHEETS.</p>

 WARNING
<p>THIS PRODUCT IS FACTORY-SHIPED WITH DRY NITROGEN MIXTURE GAS UNDER PRESSURE. USE APPROPRIATE SERVICE TOOLS AND FOLLOW THESE INSTRUCTIONS TO PREVENT INJURY.</p>

For tubing installation, follow the installation procedure below.

1. Remove the access panel on the side.
2. Remove red cap and depress the valve system to release pressure. No pressure indicates a possible leak. Use a tool to remove the red cap in case it is too tight.
3. Remove the spin closure on both the liquid and suction tubes using a tubing cutter. **DO NOT USE A CUTTING METHOD THAT WOULD RESULT IN THE GENERATION OF COPPER SHAVINGS OR COPPER DUST.**
4. Insert liquid line with liquid line insulation into liquid tube expansion
5. Braze the suction line set into suction tube expansion and ensure that suction tube insulation doesn't get damaged/ burnt while brazing.
6. Braze joints and quench all brazed joints with water or wet rag upon completion of brazing.
7. Ensure no wet rags or debris are left inside the cabinet before closing the cabinet.
8. Ensure to replace and hand-tight the red cap on the access fitting.

Braze joints should be made only with the connections provided external to the cabinet. Do not alter the cabinet or braze inside the cabinet. This system must be charged with R-32 refrigerant to operate safely.

13.1 Tubing Size

For the correct tubing size, follow the specifications for the condenser/heat pump. Give special consideration to minimizing the length of refrigerant tubing when installing coils. Refer to Remote Cooling/Heat Pump Technical Publication TP-110* Long Line Set Application for guidelines for line lengths over 80'. Leave a minimum 3" straight in-line set from braze joints before any bends.

13.2 Tubing Connections

An adjustable TXV with a bulb is installed on the vapor tube from the factory.

NOTE: When brazing the field piping, cover the pipe and its insulation using a wet rag to prevent any damage to the pipe due to thermal stresses.

IMPORTANT NOTE: Torch heat required to braze tubes of various sizes is proportional to the size of the tube. Tubes of smaller size require less heat to bring the tube to brazing temperature before adding brazing alloy. Applying too much heat to any tube can melt the tube. Service personnel must use the appropriate heat level for the size of the tube being brazed.

NOTE: The use of a heat shield when brazing is recommended to avoid burning the serial plate or the finish on the unit. Heat trap or wet rags should be used to protect heat sensitive components such as service valves and TXV valves.

13.3 Standing Pressure Test (Recommended before vacuum):

Using dry nitrogen or dry helium, pressurize the system to 460 PSIG. Allow the pressure to stabilize and hold for at least 15 minutes. The system is considered leak-free if the pressure does not drop below 460 PSIG. If, after 15 minutes, the pressure drops below 460 PSIG, it implies a leak in the system. Proceed with identifying and sealing the leak and repeating the Standing Pressure Test. Proceed to system evacuation using the Deep Vacuum Method. Leak test the system using dry nitrogen or dry helium and soapy water to identify leaks. **NO REFRIGERANT SHALL BE USED FOR PRESSURE TESTING TO DETECT LEAKS.** Proceed to system evacuation using the Deep Vacuum Method.

13.4 Deep Vacuum Method

The Deep Vacuum Method requires a vacuum pump rated for 500 microns or less. This method effectively and efficiently ensures the system is free of non-condensable air and moisture. The Triple Evacuation Method is detailed in the Service Manual for this product model as an alternative. To expedite the evacuation procedure, it is recommended that the Schrader Cores be removed from the service valves using a core-removal tool.

1. Connect the vacuum pump, micron gauge, and vacuum-rated hoses to both service valves. Evacuation must use both service valves to eliminate system mechanical seals.
2. Evacuate the system to less than 500 microns.
3. Isolate the pump from the system and hold the vacuum for 10 minutes (minimum). Typically, pressure will rise slowly during this period. If the pressure rises to less than 1000 microns and remains steady, the system is considered leak-free; proceed to system charging and startup.
4. If pressure rises above 1000 microns but holds steady below 2000 microns, non-condensable air or moisture may remain, or a small leak may be present. Return to step 2: If the same result is achieved, check for leaks and repair. Repeat the evacuation procedure.
5. If pressure rises above 2000 microns, a leak is present. Check for leaks and repair them. Then, repeat the evacuation procedure.

13.5 Detection of Refrigerant

Under no circumstances shall potential sources of ignition be used in the searching for or detection of refrigerant leaks. A halide torch (or any other detector using a naked flame) shall not be used. The following leak detection methods are deemed acceptable for all refrigerant systems. Electronic leak detectors may be used to

detect refrigerant leaks but, in the case of flammable refrigerants, the sensitivity may not be adequate, or may need recalibration. (Detection equipment shall be calibrated in a refrigerant-free area.) Ensure that the detector is not a potential source of ignition and is suitable for the refrigerant used. Leak detection equipment shall be set at a percentage of the LFL of the refrigerant and shall be calibrated to the refrigerant employed, and the appropriate percentage of gas (25 % maximum) is confirmed. Leak detection fluids are also suitable for use with most refrigerants but the use of detergents containing chlorine shall be avoided as the chlorine may react with the refrigerant and corrode the copper pipe-work.

If a leak is suspected, all naked flames shall be removed/ extinguished. If a leakage of refrigerant is found which requires brazing, all of the refrigerant shall be recovered from the system, or isolated (by means of shut off valves) in a part of the system remote from the leak.

13.6 Removal and Evacuation

When breaking into the refrigerant circuit to make repairs – or for any other purpose – conventional procedures shall be used. However, for flammable refrigerants it is important that best practice be followed, since flammability is a consideration. The following procedure shall be adhered to:

- safely remove refrigerant following local and national regulations.
- evacuate.
- purge the circuit with inert gas (optional for R-32).
- evacuate (optional for R-32).
- continuously flush or purge with inert gas when using flame to open circuit.
- open the circuit.

For appliances containing flammable refrigerants, refrigerants purging shall be achieved by breaking the vacuum in the system with oxygen-free nitrogen and continuing to fill until the working pressure is achieved, then venting to atmosphere, and finally pulling down to a vacuum (optional for R-32). This process shall be repeated until no refrigerant is within the system (optional for R-32). When the final oxygen-free nitrogen charge is used, the system shall be vented down to atmospheric pressure to enable work to take place.

The outlet for the vacuum pump shall not be close to any potential ignition sources, and ventilation shall be available.

13.7 Refrigerant Recovery

When removing refrigerant from a system, either for servicing or decommissioning, it is recommended good practice that all refrigerants are removed safely.

When transferring refrigerant into cylinders, ensure that only appropriate refrigerant recovery cylinders are employed. Ensure that the correct number of cylinders for holding the total system charge is available. All cylinders to be used are designated for the recovered refrigerant and labeled for that refrigerant (i.e. special cylinders for the recovery of refrigerant). Cylinders shall be complete with pressure-relief valve and associated shut-off valves in good working order. Empty recovery cylinders are evacuated and, if possible, cooled before recovery occurs.

The recovery equipment shall be in good working order with a set of instructions concerning the equipment that is at hand and shall be suitable for the recovery of the flammable refrigerant. If in doubt, the manufacturer should be consulted. In addition, a set of calibrated weighing scales shall be available and in good working order. Hoses shall be complete with leak-free disconnect couplings and in good condition.

The recovered refrigerant shall be processed according to local legislation in the correct recovery cylinder, and the relevant waste transfer note arranged. Do not mix refrigerants in recovery units and especially not in cylinders.

If compressors or compressor oils are to be removed, ensure that they have been evacuated to an acceptable level to make certain that flammable refrigerant does not remain within the lubricant. The compressor body shall not be heated by an open flame or other ignition sources to accelerate this process. When oil is drained from a system, it shall be carried out safely.

13.8 Thermal Expansion Valve System Adjustment

The following information for the indoor unit should be verified before attempting to charge system or adjust TXV if necessary.

NOTE: The TXV must be adjustable to meet the outdoor unit's target superheat value. During the superheat adjustment on the TXV, the torque applied on the nut cannot exceed 25 in-lbs. TXV Installation outside the coil is not allowed.

1. Total static pressure is 0.3" WC or less.
2. Airflow is correct for installed unit.
3. Airflow tables are in the installation manual and Spec Sheet for Indoor Unit.
4. Complete airflow tables and charging information are in Service Manual.
5. The outdoor temperature must be 60°F or higher.
6. Set the room thermostat to COOL, fan switch to AUTO
7. Set temperature control well below room temperature.

Superheat adjustments should not be made until indoor ambient conditions have stabilized. This could take up to 24 hours depending on the indoor temperature and humidity. Before checking superheat run the unit in cooling for 10 minutes or until refrigerant pressures stabilize. Use the following guidelines and methods to check unit operation and ensure that the refrigerant charge is within limits.

In addition to conventional charging procedures, the following requirements shall be followed:

1. Ensure that contamination of different refrigerants does not occur when using charging equipment. Hoses or lines shall be as short as possible to minimize the amount of refrigerant contained in them.
2. R-32 Refrigerant Cylinders shall be kept in an appropriate position according to the instructions.
3. Ensure that the refrigeration system is grounded prior to charging the system with refrigerant.

4. Label the system when charging is complete (if not already).
5. Extreme care shall be taken not to overfill the refrigerating system

Prior to recharging the system, it shall be pressure-tested with the appropriate purging gas. The system shall be leak-tested on completion of charging, but prior to commissioning. A follow-up leak test shall be carried out prior to leaving the site.

1. Purge gauge lines. Connect service gauge manifold to base-valve service ports.
2. Temporarily install a thermometer on the liquid line at the liquid line service valve and 4-6" from the compressor on the suction line. Ensure the thermometer makes adequate contact and is insulated for best possible readings. Use liquid line temperature to determine subcooling and vapor temperature to determine superheat.
3. If sub-cooling and superheat are low, adjust TXV superheat, then check sub-cooling as specified in outdoor Installation and Instruction manual.
 - a. If sub-cooling is low and superheat is high, add charge to raise sub-cooling 8°F +/- 1°F then, check superheat.
 - b. If sub-cooling and superheat are high, adjust TXV superheat, then check subcooling as specified in Outdoor Installation and Instruction manual.
4. After adjustments are complete reinstall cap on adjustment stem and tighten 1/6 turn.
5. Remove gauges and check the Schrader ports for leaks and tighten valve cores if necessary. Install the cap and ensure that it's hand tightened.

For optimum system performance subcool and superheat should be matched as specified in Outdoor Installation and Instruction manual. If there are no subcool/superheat instructions in Outdoor Unit Instruction Operational Manual, follow this instruction Operational Manual. Outdoor should be matched with approved AHRI combination, other approved system shall have subcooling set to 8°F ± 1°F and superheat set to 12°F ± 1°F.

NOTE:

1. The minimum time between TXV adjustments shall be 20 minutes.
2. In situations where the TXV must be removed and replaced or re-installed into the system, the TXV should be hand tightened first and then apply a half-a-turn to fully set the TXV. No more than 20 ft-lb torque should be applied to the joints of the TXV. It is not allowed to install TXV outside the coil.
3. Do NOT adjust the charge based on suction pressure unless there is a gross undercharge.

SATURATED SUCTION PRESSURE- TEMPERATURE CHART FOR R-32	
SUCTION PRESSURE (PSIG)	SATURATED SUCTION TEMPERATURE (°F)
50	1
52	2
54	4
56	5
58	6
60	8
62	9
64	10
66	12
68	13
70	14
72	15
74	17
76	18
78	19
80	20
82	21
84	22
86	23
88	24
90	25
92	26
94	27
96	28
98	29
100	30
102	31
104	32
106	33
108	34
110	35
120	40
130	44
140	48
150	52
160	55
170	59

SATURATED LIQUID PRESSURE- TEMPERATURE CHART FOR R-32	
SUCTION PRESSURE (PSIG)	SATURATED SUCTION TEMPERATURE (°F)
200	68
210	71
220	74
230	77
240	80
250	82
260	85
270	87
280	90
290	92
300	94
320	99
340	103
360	107
380	111
400	115
420	118
440	122
460	125
480	128
500	132
520	135
540	138
560	141
580	143
600	146
620	149

SUBCOOL FORMULA =
SAT. LIQUID LINE TEMP. - LIQUID LINE TEMP.

SUPERHEAT FORMULA =
SUCTION LINE TEMP. - SAT. SUCTION TEMP.

NOTE:
Specifications and Performance Data listed herein are subject to change without notice.

14 REFRIGERATION DETECTION SYSTEM (RDS)

Ceiling Mount Air Handler - Mitigation Mode Table				
Model	Minimum Air Conditioned Room Area	Minimum Air Conditioned Room Area	Minimum Required Mitigation Airflow	Mitigation Airflow Speed Tap T2 at 0.3" static pressure in W.C.
	(m²)	(ft²)	(CFM)	(CFM)
ACST18MU13**AA	17.83	191.97	346	538
ACST24LU13**AA	17.29	186.10	336	721
ACST30LU13**AA	18.49	199.02	359	721

1. Speed tap T2 is a dedicated speed for mitigation mode to meet the minimum mitigation airflow.
2. It is the installer's responsibility to verify that actuation of mitigation procedures are operational with minimum required airflow according to the chart.

Table 5

Function: Refrigerant Detection System (RDS) is installed in this equipment to detect any R-32 leakage in the coil and take action to mitigate any risk of ignition/ fire.

Operation: When a refrigerant leak is detected, the RDS shall send signals for the unit to perform these actions:

1. Turn off the thermostat
2. Turn on the blower for air circulation
3. Switch off electric heater

The mitigation mode takes about 5 minutes to complete after which it will resume normal operation. The mitigation mode table provides the required airflow and the minimum room area (In this case, the room area refers to the total conditioned airspace. Refer to Table 5: Ceiling Mount Air Handler - Mitigation Mode Table) to disperse the refrigerant without causing a potential fire hazard in presence of ignition sources.

Servicing: Before servicing identify the Mode of operation of the system by reading the LED flashing pattern on the PCB which can be seen through the round glass view on service panel and matching the LED flashing pattern with mode of operation in R-32 PCB fault code label which is attached on the front side of the service panel (Refer to Table 7). After identifying the mode of operation take recommended actions as specified in Table 8. Refer to 14.2 and 14.3 for Sensor and PCB mounting and dismounting instructions.

14.1 Altitude Adjustment Factor to Calculate Minimum Room Area

The Indoor equipment mitigation requirements are calculated at sea level. For higher altitudes adjust the minimum room area specified on the Serial Plate by the corresponding altitude adjustment factor shown below. This table is provided as a reference.

Adjusted room area (A_{min_adj}) is the product of the minimum room area specified in the serial plate and the adjustment factor AF, as shown in below formula

$$A_{min_adj} = A_{min} \text{ (serial plate)} * AF$$

Height in meters	Height in feet	Altitude Adjustment Factor (AF)
At sea level	At sea level	1.00
1~200	1~660	1.02
200~400	660~1320	1.03
400~600	1320~1970	1.05
600~800	1970~2630	1.07
800~1000	2630~3290	1.09
1000~1200	3290~3940	1.11
1200~1400	3940~4600	1.13
1400~1600	4600~5250	1.15
1600~1800	5250~5910	1.17
1800~2000	5910~6570	1.19
2000~2200	6570~7220	1.21
2200~2400	7220~7880	1.24
2400~2600	7880~8540	1.26
2600~2800	8540~9190	1.29
2800~3000	9190~9850	1.31
3000~3200	9850~10500	1.34

Table 6

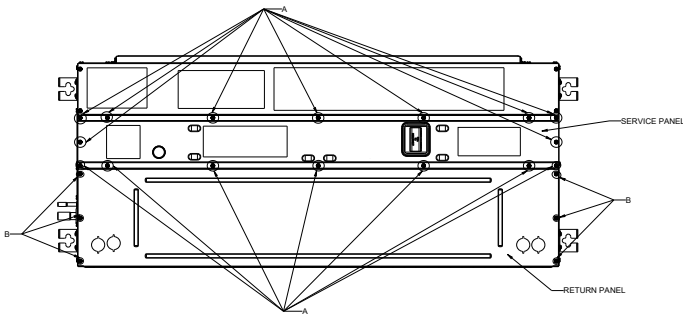

Figure A

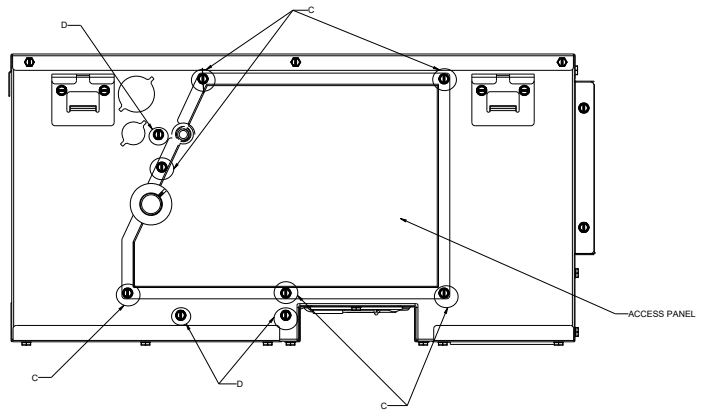

Figure B

14.2 Sensor Mounting and Dismounting Instructions

14.2.1 Sensor Dismounting Instructions

1. Detach the service panel by unfastening screw "A" (Refer to figure A).
2. Detach the return panel by unfastening screw "B" (Refer to figure A).
3. Remove the PCB Box Upper case (Refer to figure C).
4. Remove the Sensor Wire Connection from the PCB (Refer to figure D).
5. Unfasten screw "D" from the left panel (Refer to figure D).
6. Remove the sensor bracket assembly from the unit.
7. Detach the sensor from the sensor bracket assembly by unfastening screw "E" (Refer to figure E).

14.2.2 Sensor Mounting Instructions

1. Mount the sensor to the sensor bracket by placing the sensor as shown in figure E and fastening the screw "E".
2. Place the sensor bracket assembly inside the unit such that hole to mount screw "D" on the left panel aligns with the hole on the sensor bracket assembly. Then, fasten screw "D" (Refer to figure B).
3. Place the sensor wire connection on the PCB (Refer to figure D) and close the PCB box by mounting the upper case to the lower case (Refer to figure C).
4. Mount the return panel back to its original location and fasten screw "B" (Refer to figure A).
5. Mount the service panel back to its original location and fasten screw "A" (Refer to figure A).

14.3 R-32 PCB Mounting and Dismounting Instructions

14.3.1 R-32 PCB Dismounting Instructions

1. Detach the service panel by unfastening screw "A" (Refer to figure A).
2. Detach the return panel by unfastening screw "B" (Refer to figure A).
3. Remove the PCB Box Upper case (Refer to figure C).
4. Remove the Sensor Wire Connection and the PCB Wire Harness from the PCB (Refer to figure D).
5. Remove the PCB from the PCB Box carefully by pulling the PCB out.

14.3.2 R-32 PCB Mounting Instructions

1. Mount the PCB in the PCB Box by aligning the holes of PCB on the PCB Box protrusions. Press on it until you hear a click sound where the clips automatically lock the PCB in place.
2. Add the Sensor Wire Connection and the PCB Wire Harness to the PCB (Refer to figure D).
3. Close the PCB box by mounting the upper case to the lower case (Refer to figure C).
4. Mount the return panel back to its original location and fasten screw "B" (Refer to figure A).

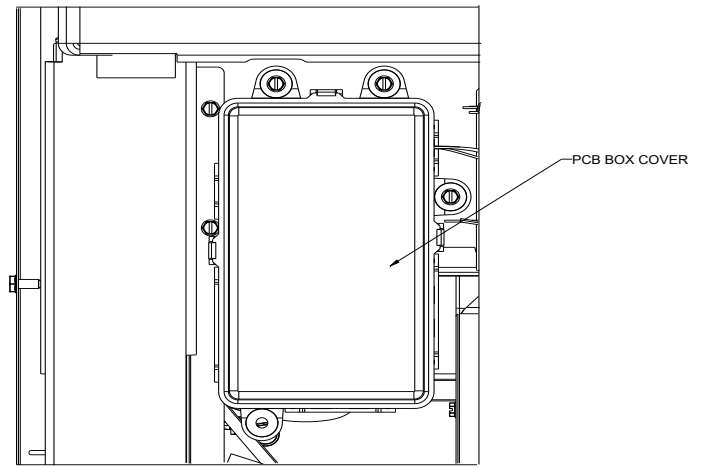

Figure C

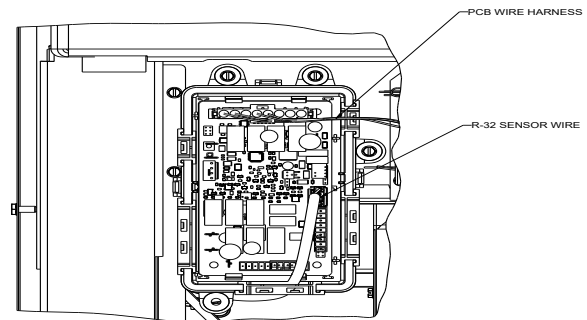

Figure D

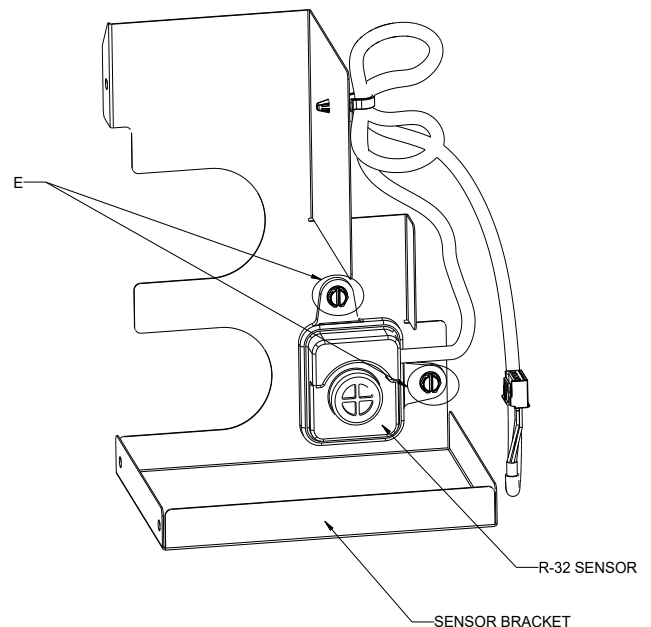

Figure E

RED LED'S STATUS					
	MODE	Definition	LED Flashing Pattern	Recommended actions	Notes:
1	Normal Operation	No faults to report	Slow LED flashing pattern (2 seconds on and 2 seconds off)	No action	
2	R-32 Leak Alarm	R-32 leak is currently being detected	Fast LED Flashing Pattern	The controls and sensor are working properly. Identify where the leak is coming from and address the leak.	
3	Delay Mode	After R-32 leak or Alarm has been cleared, the unit will remain in alarm mode for 5 minutes before returning to normal operation	LED will be on continuously	Check HVAC performance (Cooling and Heating Modes). Check system pressures and lines for any leaks. Re-Check HVAC performance after addressing any issues.	After any alarm or fault, it is required to remain in R-32 mitigation mode for 5 minutes.
4	System Verification Mode	Manual test run by contractor to simulate R-32 Leak Alarm (test will last for 5 minutes max)	Fast LED Flashing Pattern	No actions needed	To Enter system verification test mode, press the button on the control 2 times within 5 seconds. The control will enter a simulated R-32 Leak Alarm state and remain in that mode for 5 minutes. After 5 minutes, the control will return to Normal Operation automatically. If the contractor wants to end the test early, they need to press the button one time.
5	Control Board Internal Fault	Control board has detected an issue with the R-32 detection system	LED will flash 2 times and then be off for 5 seconds before repeating the pattern	1) Unplug and plug the R-32 sensor back in. Cycle power to the system. 2) If control is in Normal Operation or Delay mode, there is no more issue. If not, continue with diagnostics. 3) Unplug R-32 sensor and leave unplugged. Cycle power to the system 4) If control still displays "Control Board Internal Fault" (2 flash pattern) replace the control. If control now displays "R-32 Sensor Communication Fault" (3 flash pattern) replace the sensor	These steps will determine if the error is on the board or external to the board.
6	R-32 Sensor Communication Fault	Control board does not have communications with R-32 sensor	LED will flash 3 times and then be off for 5 seconds before repeating the pattern	1) Unplug and plug the R-32 sensor back in. Cycle power to the system. 2) If control is in Normal Operation or Delay mode, there is no more issue. If not, continue with diagnostics. 3) If control still displays "R-32 Sensor Communication Fault" (3 flash pattern), Relace both the sensor and the PCB	If the control cannot talk to the sensor there could be a problem with the sensor, a problem with the sensor harness or a problem internal to the control. The field will not be able to measure anything to reliably fix this error assuming the connector is properly secured to the control. Replacing both is the only option.
7	R-32 Sensor Fault	R-32 Sensor has reported an internal issue	LED will blink 4 times and then be off for 5 seconds before repeating the pattern	1) Unplug and plug the R-32 sensor back in. Cycle power to the system. 2) If control is in Normal Operation or Delay mode, there is no more issue. If not, continue with diagnostics. 3) If control still displays "R-32 Sensor Fault" (4 flash pattern), Relace both the sensor.	This means communications to the sensor are perfectly fine. The sensor itself is reporting an internal fault.

LEAK DETECTION SYSTEM INSTALLED. UNIT MUST BE POWERED EXCEPT FOR SERVICE.	
RED LED'S STATUS (REFER IO FOR RECOMMENDED ACTION)	
MODE	LED FLASHING PATTERN
NORMAL OPERATION	SLOW LED FLASHING PATTERN (2 SECONDS ON 2 SECONDS OFF)
R-32 LEAK ALARM*	FAST LED FLASHING PATTERN
DELAY MODE	LED WILL BE ON CONTINUOUSLY
SYSTEM VERIFICATION MODE	SAME AS R32 LEAK ALARM MODE
CONTROL BOARD INTERNAL FAULT	LED WILL FLASH 2 TIMES AND THEN BE OFF FOR 5 SECONDS
R32 SENSOR COMMUNICATION FAULT	LED WILL FLASH 3 TIMES AND THEN BE OFF FOR 5 SECONDS
R32 SENSOR FAULT	LED WILL FLASH 4 TIMES AND THEN BE OFF FOR 5 SECONDS
*IF R-32 LEAK ALARM IS OBSERVED, DO NOT OPEN THE UNIT OR TURN IT OFF.	 0140A01138-B

Figure 11

Table 7





	service indicator; read technical manual
	operator's manual; operating instructions
	warning; low burning velocity material
	UN GHS flame symbol

Table 8

15 MAINTENANCE

15.1 Room Thermostat

The room thermostat controls the operation of your heating and/or cooling unit. It senses the indoor temperature and signals the equipment to start or stop maintaining the temperature you have selected for your comfort. The room thermostat should be in a central, draft free inside wall location for best operation. Do not place any heat producing apparatus such as lights, radio, etc., near the thermostat as this will cause erratic operation of the comfort system.

15.2 Fuses and/or Circuit Breakers

This comfort equipment should be connected to the building electric service in accordance with local and National Electric codes. This electrical connection will include over current protection in the form of fuses or circuit breakers. Have your contractor identify the circuits and the location of over current protection so that you may be in a position to make inspections or replacements in the event the equipment fails to operate. Keep replacement fuses of the proper size on hand.

15.3 Periodic Checkup and Service

This unit is designed to provide many years of dependable, trouble-free comfort when properly maintained. Proper maintenance will consist of annual checkups and cleaning of the internal electrical and heat transfer components by a qualified service technician. Failure to provide periodic checkup and cleaning can result in excessive operating cost and/or equipment malfunction.

15.4 Heater Kit Service

This comfort equipment comes pre-installed with a UL2-40 certified heater kit. In times of replacement, please ensure that only a UL 2-40 certified kit is utilized.

The primary limit and the backup protection device on the electric heating element are the two components that can be replaced.

The normal limit and backup protection device installed on this product will be the below:

TOD 60TX11 Matte finish, open temperature: 140°F, close temperature: 95°F (primary limit)

TOD - Microtemp G5AM0600093C

The alternates below can be used:

5kW - **(140-45 °F + limits, 93 °C fuse-links),**

(130-30 °F+, 84 °C), (130-30 °F+, 93 °C), (130-30 °F+, 98 °C), (130-30 °F+, 104 °C), (130-30 °F+, 110 °C),

(140-45 °F+, 84 °C), (140-45 °F+, 93 °C), (140-45 °F+, 98 °C), (140-45 °F+, 104 °C), (140-45 °F+, 110 °C)

(150-50 °F+, 84 °C), (150-50 °F+, 93 °C), (150-50 °F+, 98 °C), (150-50 °F+, 104 °C), (150-50 °F+, 110 °C),

(160-60 °F+, 84 °C), (160-60 °F+, 93 °C), (160-60 °F+, 98 °C), (160-60 °F+, 104 °C), (160-60 °F+, 110 °C)

(170-70 °F+, 84 °C), (170-70 °F+, 93 °C), (170-70 °F+, 98 °C), (170-70 °F+, 104 °C), (170-70 °F+, 110 °C)

6kW - **(140-45 °F+ limits, 93 °C fuse-links),**

(130-30 °F+, 84 °C), (130-30 °F+, 93 °C)

(140-45 °F+, 84 °C), (140-45 °F+, 93 °C)

8kW - **(140-45 °F+ limits, 93 °C fuse-links),**

No alternates

10kW - **(140-45 °F+ limits, 93 °C fuse-links),**

(130-30 °F+, 93 °C)

SPLIT SYSTEMS

AIR CONDITIONING AND HEAT PUMP HOMEOWNER'S ROUTINE MAINTENANCE RECOMMENDATIONS

We strongly recommend a biannual maintenance checkup be performed before the heating and cooling seasons begin by a qualified servicer.

Replace or Clean Filter

IMPORTANT NOTE: Never operate unit without a filter installed as dust and lint will build up on internal parts resulting in loss of efficiency, equipment damage and possible fire.

An indoor air filter must be used with your comfort system. A properly maintained filter will keep the indoor coil of your comfort system clean. A dirty coil could cause poor operation and/or severe equipment damage.

Your air filter or filters could be located in your furnace, in a blower unit, or in "filter grilles" in your ceiling or walls. The installer of your air conditioner or heat pump can tell you where your filter(s) are, and how to clean or replace them.

Check your filter(s) at least once a month. When they are dirty, replace or clean as required. Disposable type filters should be replaced.

Reusable type filters may be cleaned.

You may want to ask your dealer about high efficiency filters. High efficiency filters are available in both electronic and non-electronic types.

These filters can do a better job of catching small airborne particles.

Compressor

The compressor motor is hermetically sealed and does not require additional oiling.

Motors

Indoor and outdoor fan motors are permanently lubricated and do not require additional oiling.

Aluminum Indoor Coil Cleaning (Qualified Servicer Only)

NOTE: R-32 sensor must be removed from the unit before applying coil cleaners to avoid damage and contamination. This unit is equipped with an aluminum tube evaporator coil. The safest way to clean the evaporator coil is to simply flush the coil with water. This cleaning practice remains as the recommended cleaning method for both copper tube and aluminum tube residential cooling coils.

An alternate cleaning method is to use one of the products listed in the technical publication **TP-109*** (shipped in the literature bag with the unit) to clean the coils. The cleaners listed are the only agents deemed safe and approved for use to clean round tube aluminum coils. TP-109 is available on the web site in Partner Link > Service Toolkit.

NOTE: Ensure coils are rinsed well after use of any chemical cleaners.

Clean Outside Coil (Qualified Servicer Only)

Air must be able to flow through the outdoor unit of your comfort system. Do not construct a fence near the unit or build a deck or patio over the unit without first discussing your plans with your dealer or other qualified servicer. Restricted airflow could lead to poor operation and/or severe equipment damage.

Likewise, it is important to keep the outdoor coil clean. Dirt, leaves, or debris could also restrict the airflow. If cleaning of the outdoor coil becomes necessary, hire a qualified servicer. Inexperienced people could easily puncture the tubing in the coil. Even a small hole in the tubing could eventually cause a large loss of refrigerant. Loss of refrigerant can cause poor operation and/or severe equipment damage.

Do not use a condensing unit cover to "protect" the outdoor unit during the winter, unless you first discuss it with your dealer. Any cover used must include "breathable" fabric to avoid moisture buildup.

BEFORE CALLING YOUR SERVICER

- Check the thermostat to confirm that it is properly set.
- Wait 15 minutes. Some devices in the outdoor unit or in programmable thermostats will prevent compressor operation for awhile, and then reset automatically. Also, some power companies will install devices which shut off air conditioners for several minutes on hot days. If you wait several minutes, the unit may begin operation on its own.
- Check the electrical panel for tripped circuit breakers or failed fuses. Reset the circuit breakers or replace fuses as necessary.
- Check the disconnect switch near the indoor furnace or blower to confirm that it is closed.
- Check for obstructions on the outdoor unit. Confirm that it has not been covered on the sides or the top. Remove any obstruction that can be safely removed. If the unit is covered with dirt or debris, call a qualified servicer to clean it.
- Check for blockage of the indoor air inlets and outlets. Confirm that they are open and have not been blocked by objects (rugs, curtains or furniture).
- Check the filter. If it is dirty, clean or replace it.
- Listen for any unusual noise(s), other than normal operating noise, that might be coming from the outdoor unit. If you hear unusual noise(s) coming from the unit, call a qualified servicer.



WARNING

HIGH VOLTAGE

DISCONNECT ALL POWER BEFORE SERVICING OR INSTALLING THIS UNIT. MULTIPLE POWER SOURCES MAY BE PRESENT. FAILURE TO DO SO MAY CAUSE PROPERTY DAMAGE, PERSONAL INJURY OR DEATH.



CAUTION

TO AVOID THE RISK OF EQUIPMENT DAMAGE OR FIRE, INSTALL THE SAME AMPERAGE BREAKER OR FUSE AS YOU ARE REPLACING. IF THE CIRCUIT BREAKER OR FUSE SHOULD OPEN AGAIN WITHIN THIRTY DAYS, CONTACT A QUALIFIED SERVICER TO CORRECT THE PROBLEM. IF YOU REPEATEDLY RESET THE BREAKER OR REPLACE THE FUSE WITHOUT HAVING THE PROBLEM CORRECTED, YOU RUN THE RISK OF SEVERE EQUIPMENT DAMAGE.

START-UP CHECKLIST

Air Handler / Coil			
	Model Number	_____	
	Serial Number	_____	
ELECTRICAL			
Line Voltage (Measure L1 and L2 Voltage)	L1 - L2	_____	
Secondary Voltage (Measure Transformer Output Voltage)	R - C	_____	
Blower Amps		_____	
Heat Strip 1 - Amps		_____	
Heat Strip 2 - Amps		_____	
BLOWER EXTERNAL STATIC PRESSURE			
Return Air Static Pressure		_____	IN. W.C.
Supply Air Static Pressure		_____	IN. W.C.
Total External Static Pressure (Ignoring +/- from the reading above, add total here)		_____	IN. W.C.
TEMPERATURES			
Return Air Temperature (Dry bulb / Wet bulb)		_____ DB °F	_____ WB °F
Cooling Supply Air Temperature (Dry bulb / Wet bulb)		_____ DB °F	_____ WB °F
Heating Supply Air Temperature		_____ DB °F	
Temperature Rise		_____ DB °F	
Delta T (Difference between Supply and Return Temperatures)		_____ DB °F	
Air Handler / Coil - (Inverter Matched)			
INVERTER AH / COIL ONLY			
Check EEV and EEV wiring is secure (no adjustment required)		_____	
Additional Checks			
Check wire routings for any rubbing		_____	
Check product for proper draining		_____	
Check screw tightness on blower wheel		_____	
Check factory wiring and wire connections		_____	
Check product for proper clearances as noted by installation instructions		_____	
°F to °C formula: (°F - 32) divided by 1.8 = °C °C to °F formula: (°C multiplied by 1.8) + 32 = °F			

THIS PAGE LEFT INTENTIONALLY BLANK.

THIS PAGE LEFT INTENTIONALLY BLANK.

CUSTOMER FEEDBACK

We are very interested in all product comments. Please fill out the feedback form on one of the following links:
Daikin Products: (<https://daikincomfort.com/contact-us>)
Goodman® Brand Products: (<http://www.goodmanmfg.com/about/contact-us>).
Amana® Brand Products: (<http://www.amana-hac.com/about-us/contact-us>).
You can also scan the QR code on the right for the product brand you purchased to be directed to the feedback page.



DAIKIN



GOODMAN® BRAND



AMANA® BRAND

NOTE: SPECIFICATIONS AND PERFORMANCE DATA LISTED HEREIN ARE SUBJECT TO CHANGE WITHOUT NOTICE

Quality Makes the Difference!

All of our systems are designed and manufactured with the same high quality standards regardless of size or efficiency. We have designed these units to significantly reduce the most frequent causes of product failure. They are simple to service and forgiving to operate. We use quality materials and components. Finally, every unit is run tested before it leaves the factory. That’s why we know. . .**There’s No Better Quality.**

Visit our website at www.daikincomfort.com, www.goodmanmfg.com or www.amana-hac.com for information on:

- Products
- Warranties
- Customer Services
- Parts
- Contractor Program and Training
- Financing Options

19001 Kermier Road, Waller, TX 77484

© 2024 Daikin Comfort Technologies Manufacturing, L.P.

Amana is a registered trademark of Maytag Corporation or its related companies and is used under license. All rights reserved.