



USER'S INFORMATION MANUAL

Gas-Fired Furnaces

This manual must be left with the homeowner for future reference.

Congratulations...

...you have one of the most modern gas furnaces made. Your unit has been carefully selected to keep you warm and comfortable during the winter months. It will deliver superb performance with only minimal help from you. To keep your operating costs low and to eliminate unnecessary service calls, we have provided a few guidelines. These guidelines will help you understand how your gas furnace operates and how to maintain it so you can get years of safe and dependable service. Read all the instructions in this manual, and keep all manuals for future reference.



AHRI Certified

The Air-Conditioning, Heating and Refrigeration Institute (AHRI) symbol verifies that Annual Fuel Utilization Efficiency (AFUE) ratings for our gas furnaces have been derived from U.S. Government standard tests.

CSA International Design Certified

The CSA International symbols on each nameplate is your assurance that your furnace design meets nationally recognized standards for safety and performance.

WARNING

FIRE OR EXPLOSION HAZARD

Failure to follow the safety warnings exactly could result in serious injury, death, or property damage.

WARNING

This furnace is equipped with an ignition control factory enabled for use with A2L refrigerant systems. Disabling the refrigerant detection functionality on A2L system is prohibited by safety codes. Refer to furnace installation instructions for non-A2L refrigerant system setup.

WARNING

Do not store or use gasoline or other flammable vapors and liquids in the vicinity of this or any other appliance.

WHAT TO DO IF YOU SMELL GAS

- Do not try to light any appliance.
- Do not touch any electrical switch; do not use any phone in your building.
- Leave the building immediately.
- Immediately call your gas supplier from a neighbor's phone. Follow the gas supplier's instructions.
- If you cannot reach the gas supplier, call the fire department.

Installation and service must be performed by a qualified installer, service agency, or the gas supplier.

215 Metropolitan Drive
West Columbia, SC 29170



(P) 508630-01

NOTE: This manual is the property of the homeowner and must be left with the equipment user.

Notice to Homeowner

This furnace is equipped with safety devices that protect you and your property. If one or more of these devices is activated, furnace operation will stop. If your home is left unattended for an extended period of time, equipment operation must be checked periodically. If this is not possible, the water supply to the house should be shut off and the pipes should be drained. This will prevent problems associated with a NO HEAT condition (frozen pipes, etc.).

CAUTION

Before attempting to perform any service or maintenance, turn the electrical power to unit OFF at the disconnect switch.

WARNING

Do not set thermostat below 60° F (16° C) in heating mode. Setting thermostat below 60° F (16° C) reduces the number of heating cycles. Damage to the unit may occur that is not covered by the warranty.

WARNING

If overheating occurs or if gas supply fails to shut off, shut off the manual gas valve to the furnace before shutting off electrical supply.

WARNING

Do not use this furnace if any part has been underwater. A flood-damaged furnace is extremely dangerous. Attempts to use the furnace can result in fire or explosion. Immediately call a licensed professional service technician (or equivalent) to inspect the furnace and to replace all gas controls, control system parts, and electrical parts that have been wet or to replace the furnace, if deemed necessary.

NOTICE

Any additions, changes, or conversions required in order for the appliance to satisfactorily meet the application needs must be made by a licensed professional installer (or equivalent) using factory-specified and approved parts.

WARNING

Improper installation, adjustment, alteration, service or maintenance can cause property damage, personal injury or loss of life. Installation and service must be performed by a licensed professional installer (or equivalent), a service agency, or the gas supplier.

Safety Instructions

1. Keep the furnace area clear and free of combustible material, gasoline, and other flammable vapors and liquids. If it is installed in an insulated area, the furnace must be kept free of insulating material. Insulating material may be combustible.
2. After any heavy snow, ice or frozen fog event, the furnace vent pipes may become restricted. Always check the vent system and remove any snow or ice that may be obstructing the exhaust pipe and intake pipe (where applicable).
3. **DO NOT** obstruct air flow to unit. Unit must receive an unobstructed flow of combustion and ventilating air. **DO NOT** block or obstruct air openings on the furnace or air openings to the area in which the furnace is installed. Take care to maintain established clearances surrounding the furnace.
4. **DO NOT** store chlorine or fluorine products near unit or introduce these products into the combustion air. These products can cause furnace corrosion.
5. **DO NOT** draw return air from a room where this furnace, or any other gas appliance (ie., a water heater), is installed. When return air is drawn from a room, a negative pressure is created in the room. If a gas appliance is operating in a room with negative pressure, the flue products can be pulled back down the vent pipe and into the room. This reverse flow of the flue gas may result in incomplete combustion and the formation of carbon monoxide gas. This toxic gas might then be distributed throughout the house by the furnace duct system.

⚠ WARNING

The blower door must be securely in place when the blower and burners are operating. Gas fumes, which could contain carbon monoxide, can be drawn into the living space resulting in personal injury or death.

Your furnace is a gas appliance. It is critical that the gas supplied to the unit be completely burned to avoid the production of carbon monoxide gas. Complete combustion of the gas requires, but is not limited to correct gas pressure and gas flow rate, adequate combustion air, and proper venting.

⚠ WARNING

Carbon monoxide gas is invisible, odorless and toxic.

Exposure to carbon monoxide gas can cause personal injury and even death to all occupants, including pets. Any item that is powered by or gives off heat from a combustion process (including lawn mowers, automobiles, and fireplaces) has the potential to produce carbon monoxide gas. Because of this, we recommend the use of a carbon monoxide detector in your home, even if you do not own gas appliances. Reliable detectors are available at reasonable retail prices.

Your furnace is designed to meet standards set by national agencies, and to operate safely when properly installed and maintained. However, the unit's performance can be greatly impacted by the individual installation and the operating environment. It is your responsibility to ensure that this appliance is maintained. Proper maintenance is critical for your safety and the satisfactory operation of the product. It is strongly recommended that annual inspections and maintenance of this appliance be performed. Contact your dealer for an inspection by a licensed professional service technician (or equivalent).

⚠ DANGER

DANGER OF EXPLOSION!

There are circumstances in which odorant used with LP/ propane gas can lose its scent. In case of a leak, LP/ propane gas will settle close to the floor and may be difficult to smell. An LP/propane leak detector should be installed in all LP applications.

Start-Up and Operational Information

⚠ WARNING

If you do not follow these instructions exactly, a fire or explosion may result causing property damage, personal injury or death.

BEFORE PLACING THE UNIT INTO OPERATION, smell all around the appliance area for gas. Be sure to smell next to the floor because some gas is heavier than air and will settle on the floor.

The gas valve on this unit is equipped with a gas control switch. Use only your hand to move the switch. Never use tools. If the switch will not move by hand, do not try to repair it. Call a licensed professional service technician (or equivalent). Force or attempted repair may result in a fire or explosion.

Placing the Gas Furnace Into Operation

These units are equipped with an ignition system. **DO NOT** attempt to manually light burners on this furnace.

Each time the thermostat calls for heat, the burners will automatically light. The ignitor does not get hot when there is no call for heat on units with this ignition system.

Operating the Gas Valve

See Figure 1 through Figure 3

1. **STOP!** Read the safety information at the beginning of this section.
2. Set the thermostat to the lowest setting.
3. Turn **OFF** all electrical power to the unit.
4. This furnace is equipped with an ignition device which automatically lights the burners. **DO NOT** try to light the burners by hand.
5. Remove the heating compartment access panel.
6. Move switch on gas valve to **OFF**. See Figure 1 through Figure 3.
7. Wait five minutes to clear out any gas. If you then smell gas, **STOP!** Immediately call your gas supplier from a neighbor's phone. Follow the gas supplier's instructions. If you do not smell gas proceed to the next step.
8. Move switch on gas valve to **ON**. See Figure 1 through Figure 3.
9. Replace the heating compartment access panel.
10. Turn on all electrical power to the unit.
11. Set the thermostat to desired setting.

NOTE: *When unit is initially started, steps 1 through 11 may need to be repeated to purge air from gas line.*

12. If the appliance will not operate, follow the section "Turning Off Gas to the Unit" and call your licensed professional service technician (or equivalent.).

Turning Off Gas to the Unit

1. Set the thermostat to the lowest setting.
2. Turn **OFF** all electrical power to the unit if service is to be performed.
3. Remove the heating compartment access panel.
4. Move switch on gas valve to the **OFF** position.
5. Replace the heating compartment access panel.

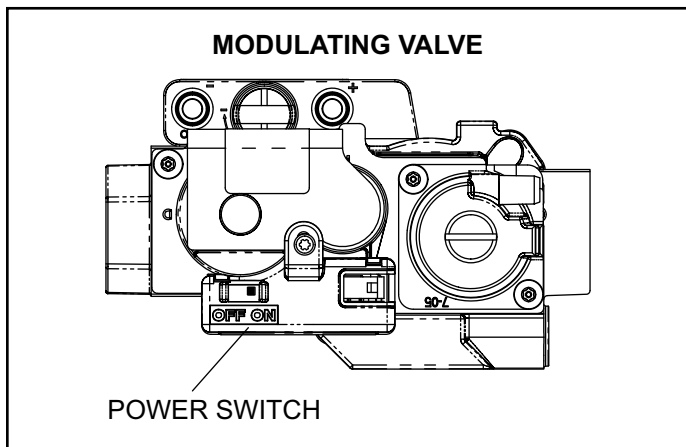

Figure 1. Modulating Gas Valve

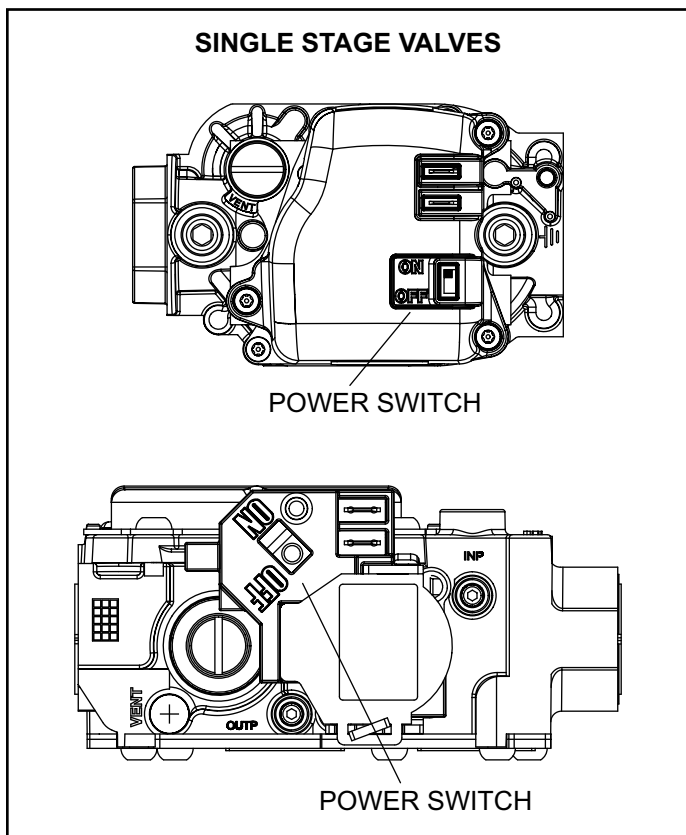

Figure 2. Single Stage Gas Valves

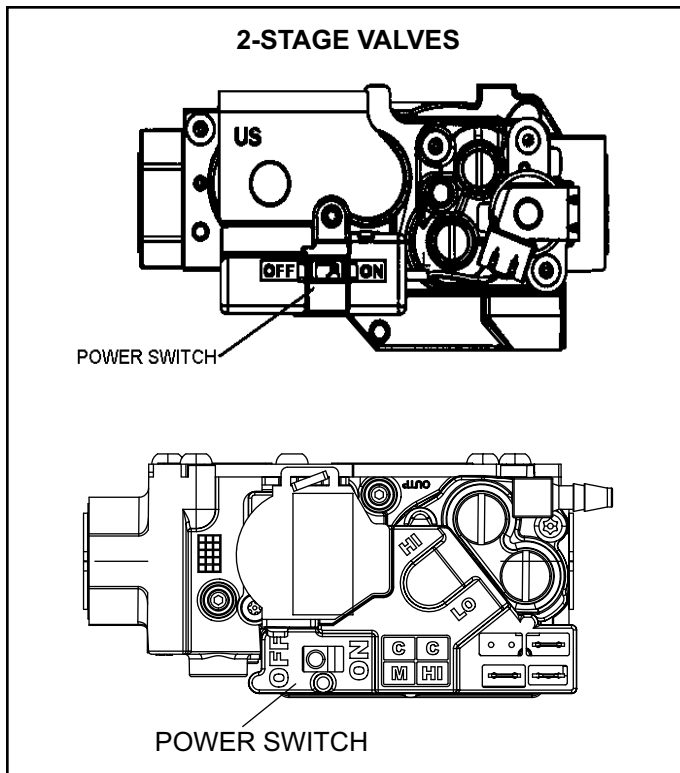

Figure 3. Two-Stage Gas Valves

Filters

All filters are installed external to the unit. Filters should be inspected monthly. Clean or replace the filters when necessary to ensure proper furnace operation.

Replacement filters must be rated for high velocity airflow. Table 1 lists recommended filter sizes. A filter must be in place when the unit is operating.

Furnace Cabinet Width	Filter Size	
	Side Return	Bottom Return
14-1/2"	16 x 25 x 1 (1)	14 x 25 x 1 (1)
17-1/2"		16 x 25 x 1 (1)
21"	16 x 25 x 1 (2)	20 x 25 x 1 (1)
24-1/2"		24 x 25 x 1 (1)

Table 1.

Maintenance

A licensed professional service technician (or equivalent) should inspect the complete system each season (heating and cooling). The following maintenance procedures should only be conducted by a licensed professional service technician (or equivalent). Do not attempt to service the unit in any way.

⚠ WARNING

ELECTRICAL SHOCK, FIRE, OR EXPLOSION HAZARD

Failure to follow safety warnings exactly could result in dangerous operation, serious injury, death or property damage.

Improper servicing could result in dangerous operation, serious injury, death, or property damage.

Before servicing controls, disconnect all electrical power to furnace.

When servicing controls, label all wires prior to disconnecting. Take care to reconnect wires correctly.

Verify proper operation after servicing.

Annually (before heating season) inspect furnace venting system, vent cap, heat exchanger, and burners for corrosion, deterioration, or deposits of debris. Remove any obstructions.

During a seasonal check the service technician will conduct a combustion analysis. The technician will also inspect the indoor blower, burner flames, electrical connections and the venting system.

Venting System

⚠ WARNING

ASPHYXIATION HAZARD

The exhaust vent for this furnace must be leak-free and must be securely connected to the furnace flue collar at all times.

For your safety and to fulfill the terms of the limited warranty, a licensed professional service technician (or equivalent) must annually inspect this furnace and its vent system.

⚠ WARNING

CARBON MONOXIDE POISONING HAZARD

Failure to follow instructions could result in severe personal injury or death due to carbon-monoxide poisoning, if combustion products infiltrate the building.

Check that all openings in the outside wall around the vent (and air intake) pipe(s) are sealed to prevent infiltration of combustion products into the building.

Check that furnace vent (and air intake) terminal (s) are not obstructed in any way during all seasons.

Inspect the furnace for obvious signs of deterioration. Inspect the furnace venting system to make sure it is in place, physically sound, and without holes, corrosion, or blockage.

Vent pipe must be clear and free of obstructions and must slope upward away from the furnace.

Ductwork

Inspect the furnace return air duct connection to ensure duct is sealed to the furnace and terminates outside the space containing the furnace.

Inspect the physical support of the furnace to guarantee that it is sound without sagging and it maintains a proper seal between unit and ductwork.

Drain and Trap

On condensing furnaces (90% efficient and higher), inspect the condensate drain and trap for leaks and cracks. The drain and trap must also be cleaned and the trap must be filled with water.

Blower (Circulating Air)

Check the blower wheel for debris and clean if necessary. The blower motors are pre-lubricated for extended bearing life. No further lubrication is needed.

⚠ WARNING

The blower access panel must be securely in place when the blower and burners are operating. Gas fumes, which could contain carbon monoxide, can be drawn into living space resulting in personal injury or death.

Burner Flame

⚠ CAUTION

To ensure proper operation, a licensed professional service technician (or equivalent) should check the burner flame and conduct a combustion analysis annually.

Cleaning/Replacing the Filter

It is very important to clean or replace the air filter regularly. Dirty filters are the most common cause of inadequate heating or cooling performance and can sharply increase the operational costs of your unit. In some cases, they can double the cost. **The air filter should be inspected at least every 6 weeks and cleaned or replaced as required.**

Your furnace may use either a disposable filter or a cleanable filter. The type of filter may be indicated on a

label attached to the filter. If a disposable filter is used, replace with the same type and size. To remove excess dirt from a cleanable filter, shake filter and/or use a vacuum cleaner. Wash filter in soap or detergent water and replace after filter is dry. Cleanable filters do not need to be oiled after washing.

NOTE: *Cleanable filters may be replaced with disposable filters. Consult with a service technician for more information.*

If your air distribution system has a central return air filter-grille, the furnace does not need a filter. Filter-grilles can be maintained the same way as cleanable filters (see above).

SERVICE REMINDER

Call your service technician if unit will not operate. Before calling, always check the following to be sure service is required:

1. Check that electrical disconnect switches are ON.
2. Check room thermostat for proper setting.
3. Replace any blown fuses or reset circuit breakers.
4. Gas valve should be ON.
5. Air filter should not be plugged, which will limit air flow.
6. Is gas turned on at meter?
7. Is manual main shut-off valve open?

Record the model and serial number of the furnace. These numbers are on the unit nameplate.

Serial Number: _____

Model Number: _____

Safety Precautions

If you discover any of the following, shut down your unit, and contact a dealer for an inspection by a licensed professional service technician (or equivalent).

- If you repeatedly hear any new or unfamiliar sounds while your unit is operating, there may be a problem. For example, poorly performing burners can produce unfamiliar noises.
- If you smell any unusual odors, your unit may be operating improperly. For example, units can give off unfamiliar odors if components are required to operate in abnormal conditions.
- Look for visible signs of a malfunctioning unit. Examples include unusual amounts of condensate on windows inside your house, visibly burnt components or unusual dirt or rust accumulations on the vent pipe or in the unit.

- If you experience headache, nausea, fatigue, or dizziness, the cause could be exposure to carbon monoxide gas. This is often misdiagnosed as the flu because symptoms are similar. If you suffer from flu-like symptoms that are exaggerated at home, but seem to subside while you are away from the house, exposure to carbon monoxide could be the cause.
- If the indoor blower is running continuously at the cooling speed when thermostat is not calling for cooling demand you may have a refrigerant leak.

Your vigilance may pay off in early detection of a problem before either personal injury or property damage occurs.

Do not hesitate to contact a qualified service technician as an investment in your well being.

Planned Service

You should expect a service technician to check the following items during an annual inspection. Power to the unit must be shut off for the service technician's safety.

Fresh air grilles and louvers (on the unit and in the room where the furnace is installed) – Must be open and unobstructed to provide combustion air.

Burners - Must be inspected for rust, dirt, or signs of water.

Vent Pipe - Must be inspected for signs of water, damaged or sagging pipe, or disconnected joints.

Unit Appearance - Must be inspected for rust, dirt, signs of water, burnt or damaged wires, or components.

Blower Access Door - Must be properly in place and provide a seal between the return air and the room where the furnace is installed.

Return Air Duct - Must be properly attached and provide an air seal to the unit.

Operating Performance - Unit must be observed during operation to monitor proper performance of the unit and the vent system.

Combustion Gases - Flue products must be analyzed and compared to the unit specifications.

Problems detected during the inspection may make it necessary to temporarily shut down the furnace until the items can be repaired or replaced.

Pay attention to your furnace. Situations can arise between annual furnace inspections that may result in unsafe operation. For instance, items innocently stored next to the furnace may obstruct the combustion air supply. This could cause incomplete combustion and the production of carbon monoxide gas.

Inspect thermostat wires and refrigerant sensors for damage.

The refrigerant leak detection sensor must be inspected for dust/debris deposits. Please refer to the evaporator coil and/or refrigerant detection sensor kit instructions for additional information.

Low GWP (A2L) mitigation capability must be tested per the low GWP test button functionality section in the furnace installation instructions.

Repair Parts List

The following repair parts are available from your local distributor. When ordering parts, include the complete furnace model number and serial number listed on the unit nameplate. All service must be done by a licensed professional installer (or equivalent), a service agency, or the gas supplier.

Cabinet Parts

- Heating Compartment Access Panel
- Blower Access Panel
- Top Cap

Control Panel Parts

- Transformer
- Integrated Control
- Door Interlock Switch

Blower Parts

- Blower Wheel
- Motor
- Motor Mounting Frame
- Blower Housing Cutoff Plate

Heating Parts

- Flame Sensor
- Heat Exchanger Assembly
- Gas Manifold
- Combustion Air Inducer
- Gas Valve
- Main Burner Cluster
- Main Burner Orifices
- Pressure Switches
- Ignitor
- Primary Limit Control
- Secondary Limit Control
- Flame rollout switches

Low GWP Refrigerant detection System Parts

- RDS sensor
- Refrigerant line set sleeve

ATTENTION HOMEOWNER

Check for the "WARRANTY" document in the business size envelope in literature bag assembly inside of box your unit came in.

(If for some unknown reason you cannot find the warranty, please go online at www.alliedair.com to print out one.)