

BA713S

Single-Stage | R-454B | 60Hz

RESIDENTIAL
PRODUCT SPECIFICATIONS

SEER2 13.4 to 16.0
Cooling Capacity | 1.5 to 5 Tons



MODEL NUMBER IDENTIFICATION

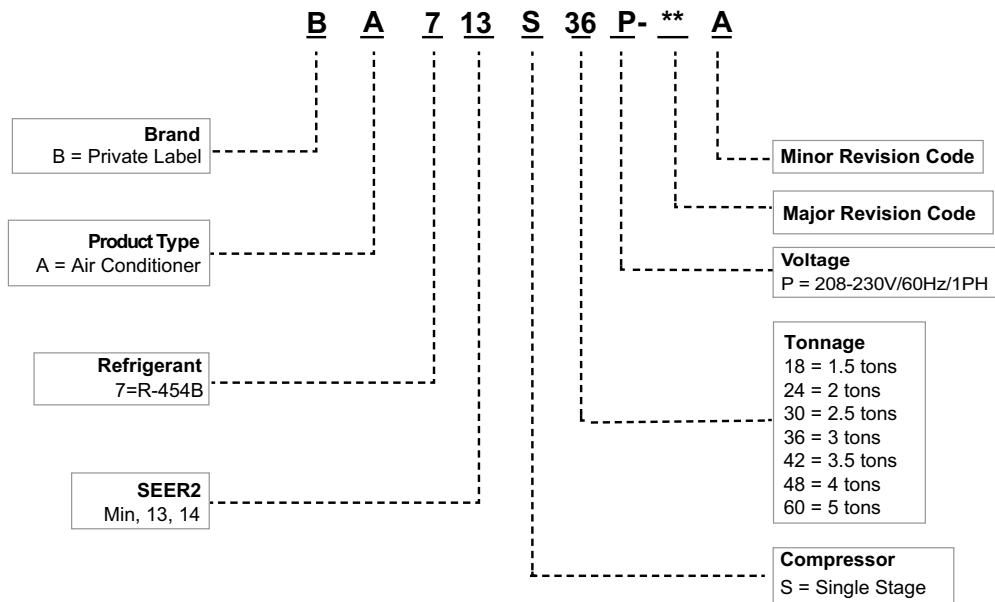

FEATURE HIGHLIGHTS

- Outdoor Coil Fan
- Outdoor Coil
- High Capacity Liquid Line Drier
- High Pressure Switch
- Low Pressure Switch
- Scroll Compressor
- Heavy Gauge Steel Cabinet
- Refrigerant Line Connections and Access

CONTENTS

Model Number Identification	1
Approvals And Warranty	3
Features.	3
Electrical Data.	6
Optional Accessories - Order Separately	6
Specifications	6
Dimensions - Unit	8
Field Wiring	9
Installation Clearances	9
Sound Data	9
TXV Substitution	10
TXV Usage	10
Cooling Performance Extended Ratings	11
Revisions	15

APPROVALS AND WARRANTY

APPROVALS

- AHRI Standard 210/240-2023 certified
- AHRI Certified system match-ups and expanded ratings, visit www.alliedratings.com
- ENERGY STAR® Certified
- Sound rated to AHRI Standard 270-2008 test conditions
- Rated According to U.S. Department of Energy (DOE) test procedures
- Region specific models meet the minimum efficiency requirements for U.S. DOE Federal Regional Standards in that area
- Unit and components ETL, NEC and CEC bonded for grounding to meet safety standards for servicing
- ETL certified (U.S. and Canada)
- ISO 9001 Registered Manufacturing Quality System

WARRANTY

10-years limited warranty on all parts, extended warranty available.

Coverage (Standard 5-year limited parts warranty plus an additional 5-year limited extended parts warranty).

Warranty must be registered online within 60 days of installation to qualify for 10-year coverage.

Unregistered equipment defaults to 5-year coverage.

See full warranty at www.alliedair.com for terms, conditions, and exclusions.

FEATURES

APPLICATIONS

- 1.5 through 5 tons
- Sound levels as low as 73 dBA
- Single-phase power supply
- Vertical air discharge
- Applicable to indoor air handlers or gas furnaces with indoor add-on coils
- Shipped completely factory assembled, piped and wired
- Factory test operated

REFRIGERATION SYSTEM

R-454B Refrigerant

- Low GWP (Global Warming Potential)
- Zero ODP (Ozone Depletion Potential)
- Unit is factory pre-charged

Outdoor Coil Fan

- Direct drive fan
- Vertical air discharge
- Totally enclosed fan motor
- Sleeve bearings (018 through 048 and 060 models)
- Inherently protected
- Motor rain shield
- Louvered steel fan guard

Outdoor Coil

- Proprietary coil design
- Enhanced aluminum alloy tube/enhanced fin coil
- Superior corrosion resistance
- Ripple-edged aluminum fins
- Aluminum tube construction
- Lanced fins for maximum fin surface exposure
- Fin collars grip tubing for maximum contact area
- Flared shoulder tubing connections
- Factory tested under high pressure
- Entire coil is accessible for cleaning

High Capacity Liquid Line Drier

- Furnished with unit for field installation
- Drier traps moisture or dirt that could contaminate the system
- 100% molecular-sieve, bead type, drier

High Pressure Switch

- Protects the system from high pressure conditions that can be a result of fan failure or a blocked/dirty coil
- Manual reset

Low Pressure Switch

- Shuts off unit if suction pressure falls below setting
- Provides loss of charge and freeze-up protection
- Automatic reset

FEATURES

REFRIGERATION SYSTEM (continued)

Optional Accessories

Expansion Valve Kits

- Factory installed with R-454B on all indoor units
- See TXV Usage table
- Chatleff-style fitting

Freezestat

- Senses suction line temperature
- Cycles compressor off when suction line temperature falls below freezestat setpoint
- Opens at 29°F and closes at 58°F
- Installs on or near the discharge line of the evaporator or on the suction line

Loss of Charge Switch Kit

- Protects compressor from damage from low refrigerant charge conditions
- SPST, normally-closed
- Automatic reset

INDOOR REFRIGERANT DETECTION SYSTEM (RDS)

- Complies with UL 60335-2-40 approved standard
- Required for all systems using R-454B refrigerant
- Factory or field installed on all indoor units
- Consists of a RDS refrigerant detection sensor and an independent RDS control
- If refrigerant is detected the refrigerant detection system will prevent compressor and heating operation until refrigerant is no longer detected
- Refrigeration detection system also energizes the blower if refrigerant is detected to dissipate any concentrations of refrigerant from the space
- Refer to indoor unit Product Specifications documents for additional details

COMPRESSOR

Single-Stage Scroll Compressor

- High volumetric efficiency
- Uniform suction flow
- Constant discharge flow
- High efficiency
- Quiet operation
- Low gas pulses during compression reduces operational sound levels.
- Compressor motor is internally protected from excessive current and temperature
- Muffler in discharge line reduces operating sound levels
- Compressor is installed in the unit on resilient rubber mounts for vibration free operation

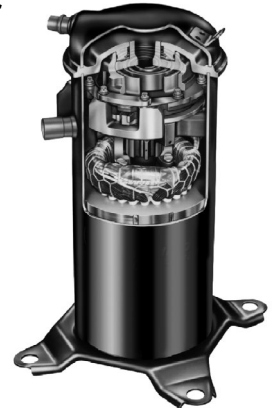

Scroll Compressor Operation

- Two involute spiral scrolls matched together generate a series of crescent-shaped gas pockets between them
- During compression, one scroll remains stationary while the other scroll orbits around it
- Gas is drawn into the outer pocket, the pocket is sealed as the scroll rotates
- As the spiral movement continues, gas pockets are pushed to the center of the scrolls. Volume between the pockets is simultaneously reduced
- When the pocket reaches the center, gas is now at high pressure and is forced out of a port located in the center of the fixed scrolls
- During compression, several pockets are compressed simultaneously resulting in a smooth continuous compression cycle
- Continuous flank contact, maintained by centrifugal force, minimizes gas leakage and maximizes efficiency
- Compressor is tolerant to the effects of slugging and contaminants. If this occurs, scrolls separate, allowing liquid or contaminants to be worked toward the center and discharged

Compressor Crankcase Heater (048, 060 Models)

- Prevents migration of liquid refrigerant into compressor and ensures proper compressor lubrication

Optional Accessories

Compressor Crankcase Heater

(018, 024, 030, 036, 042 Models)

- Prevents migration of liquid refrigerant into compressor and ensures proper compressor lubrication

Compressor Sound Cover

- Polymer outer shell
- 1/2 inch thick polyester fiber insulation
- All open edges are sealed with a one-inch wide hook and loop fastening tape

FEATURES

COMPRESSOR (continued)

Optional Accessories (continued)

Compressor Hard Start Kit

- Single-phase units are equipped with a PSC compressor motor
- This type of motor normally does not need a potential relay and start capacitor
- For conditions such as low voltage, kit may be required to increase the compressor starting torque

Compressor Low Ambient Cut-Off Switch

- Non-adjustable switch (low ambient cut-out)
- Prevents compressor operation when outdoor temperature is below 35°F

Compressor Time-Off Control

- Kit prevents compressor short-cycling
- Allows time for suction and discharge pressure to equalize
- Permits compressor start-up in an unloaded condition.
- Automatic reset with 5 minute delay between compressor shut-off and start-up

Indoor Blower Off Delay Relay

- Delays the indoor blower-off time during the cooling cycle

Low Ambient Kit

- Air conditioners can operate down to 45°F outdoor air temperature without additional controls
- Allows unit to operate properly down to 30°F

NOTE - Crankcase heater and freezestat should be installed on compressors equipped with a low ambient kit.

NOTE - A compressor lock-out thermostat should be added to terminate compressor operation below recommended operation conditions.

CABINET

- Heavy gauge steel construction
- Louvered heavy gauge steel panels surround unit on all four sides
- Pre-painted cabinet finish
- Control box is conveniently located with all controls factory wired
- Corner patch plate allows access to compressor components
- Drainage holes are provided in base section for moisture removal

Refrigerant Line Connections, Electrical Inlets, Service Valves

- Sweat connection suction and liquid lines
- Located on corner of unit cabinet
- Suction valve can be fully shut off, while liquid valve may be front seated to manage refrigerant charge while servicing system
- Refrigerant line connections and field wiring inlets are located in one central area of the cabinet
- See dimension drawing

Braze-Free/Press Fitting Flexibility

- Units can accommodate braze-free or press fittings for installation versatility.

SPECIFICATIONS			NORTH REGION			
Size			018	024	030	036
Nominal Tonnage			1.5	2	2.5	3
Sound Rating Number		dB	73	76	76	76
Connections (Sweat)	Liquid line (OD) - in.		3/8	3/8	3/8	3/8
	Suction line (OD) - in.		3/4	3/4	3/4	7/8
Compressor Type			1-Stage Scroll	1-Stage Scroll	1-Stage Scroll	1-Stage Scroll
Refrigerant	¹ R-454B charge furnished @ 15 FT		4 lbs. 0 oz.	4 lbs. 7 oz.	4 lbs. 14 oz.	5 lbs. 10 oz.
	¹ R-454B charge furnished @ 30 FT		4 lbs. 9 oz.	5 lbs. 0 oz.	5 lbs. 7 oz.	6 lbs. 3 oz.
Indoor Unit Expansion Valve (TXV)			26Z70	26Z70	26Z70	26Z70
Outdoor Coil	Net face area - ft. ²		11.33	13.22	16.33	18.67
	Tube diameter - in.		5/16	5/16	5/16	5/16
	Rows		1	1	1	1
	Fins - in.		26	26	26	26
Outdoor Fan	HP		1/10	1/10	1/6	1/6
	Diameter - in.		18	18	22	22
	Blades		3	3	3	3
	Cfm		2290	2350	2610	2800
	Rpm		1075	1075	825	825
	Watts		150	155	160	190
Shipping Data - lbs.			128	134	152	161
ELECTRICAL DATA						
	Line voltage data (Volts-Phase-Hz)		208/230-1-60	208/230-1-60	208/230-1-60	208/230-1-60
	² Maximum overcurrent protection (MOCP) amps		15	20	25	30
	³ Minimum circuit ampacity (MCA)		11.1	13.5	16.6	17.8
Compressor	Rated load amps		8.3	10.2	12.5	13.4
	Locked rotor amps		45	60.2	67.8	82.5
Fan Motor	Full load amps		0.65	0.65	1.0	1.0
	Locked rotor amps		1.3	1.3	1.9	1.9
OPTIONAL ACCESSORIES - ORDER SEPARATELY						
Compressor Crankcase Heater	Copeland	27V63	•	•	•	•
	LG	27U16	•	•	•	•
Compressor Hard Start Kit	Copeland	63W22	•			
		10J42		•	•	•
	LG	10J42	•	•	•	•
Compressor Low Ambient Cut-Off Switch		45F08	•	•	•	•
Compressor Timed-Off Control		47J27	•	•	•	•
Compressor Sound Cover		18J42	•	•	•	•
Freezestat	3/8 in.	93G35	•	•	•	•
Indoor Blower Off Delay Relay		58M81	•	•	•	•
Loss of Charge Switch Kit		84M23	•	•	•	•
⁴ Low Ambient Kit (Fan Cycling)		34M72	•	•	•	•

NOTE - Extremes of operating range are plus 10% and minus 5% of line voltage.

¹ Refrigerant charge is sufficient for 15/30 ft. length of refrigerant lines. For longer line set requirements see the Installation Instructions for information about line set length and additional refrigerant charge required.

² HACR type breaker or fuse.

³ Refer to National or Canadian Electrical Code manual to determine wire, fuse and disconnect size requirements.

⁴ Crankcase Heater and Freezestat are recommended with Low Ambient Kit.

SPECIFICATIONS				NORTH REGION		
Size			042	048	060	
Nominal Tonnage			3.5	4	5	
Sound Rating Number		dB	76	78	80	
Connections (Sweat)	Liquid line (OD) - in.		3/8	3/8	3/8	
	Suction line (OD) - in.		7/8	7/8	1-1/8	
Compressor Type			1-Stage Scroll	1-Stage Scroll	1-Stage Scroll	
Refrigerant	¹ R-454B charge furnished @ 15 FT		6 lbs. 2 oz.	7 lbs. 10 oz.	8 lbs. 8 oz.	
	¹ R-454B charge furnished @ 30 FT		6 lbs. 11 oz.	8 lbs. 3 oz.	9 lbs. 1 oz.	
Indoor Unit Expansion Valve (TXV)			26Z71	26Z71	26Z72	
Outdoor Coil	Net face area - ft. ²	Outer coil	21.00	16.33	21.00	
		Inner coil	---	16.33	20.25	
	Tube diameter - in.		5/16	5/16	5/16	
	Rows		1	2	2	
	Fins - in.		26	22	22	
Outdoor Fan	HP		1/3	1/4	1/4	
		Diameter - in.	22	22	22	
	Blades		3	3	4	
	Cfm		2985	2875	3250	
	Rpm		825	825	845	
	Watts		150	160	280	
Shipping Data - lbs.			195	215	250	
ELECTRICAL DATA						
	Line voltage data (Volts-Phase-Hz)		208/230-1-60	208/230-1-60	208/230-1-60	
	² Maximum overcurrent protection (MOCP) amps		35	40	50	
	³ Minimum circuit ampacity (MCA)		21.2	24.3	31.3	
Compressor	Rated load amps		14.9	18.0	23.7	
	Locked rotor amps		109	126	157	
Fan Motor	Full load amps		2.6	1.7	1.7	
	Locked rotor amps		---	3.2	3.2	
OPTIONAL ACCESSORIES - ORDER SEPARATELY						
Compressor	Copeland	27P59	•	Factory Installed	Factory Installed	
Crankcase Heater	LG	27U16	•	Factory Installed	Factory Installed	
Compressor Hard Start Kit	Copeland	10J42	•	•	•	
	LG	88M91	•	•	•	
Compressor Low Ambient Cut-Off Switch		45F08	•	•	•	
Compressor Sound Cover		18J42	•	•	•	
Compressor Timed-Off Control		47J27	•	•	•	
Freezestat	3/8 in.	93G35	•	•	•	
Indoor Blower Off Delay Relay		58M81	•	•	•	
Loss of Charge Switch Kit		84M23	•	•	•	
⁴ Low Ambient Kit (Fan Cycling)		34M72	•	•	•	

NOTE - Extremes of operating range are plus 10% and minus 5% of line voltage.

¹ Refrigerant charge is sufficient for 15/30 ft. length of refrigerant lines. For longer line set requirements see the Installation Instructions for information about line set length and additional refrigerant charge required.

² HACR type breaker or fuse.

³ Refer to National or Canadian Electrical Code manual to determine wire, fuse and disconnect size requirements.

⁴ Crankcase Heater and Freezestat are recommended with Low Ambient Kit.

DIMENSIONS - UNIT

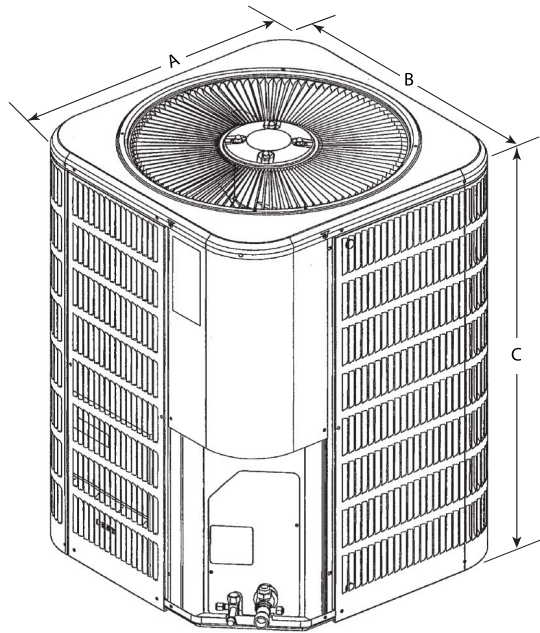
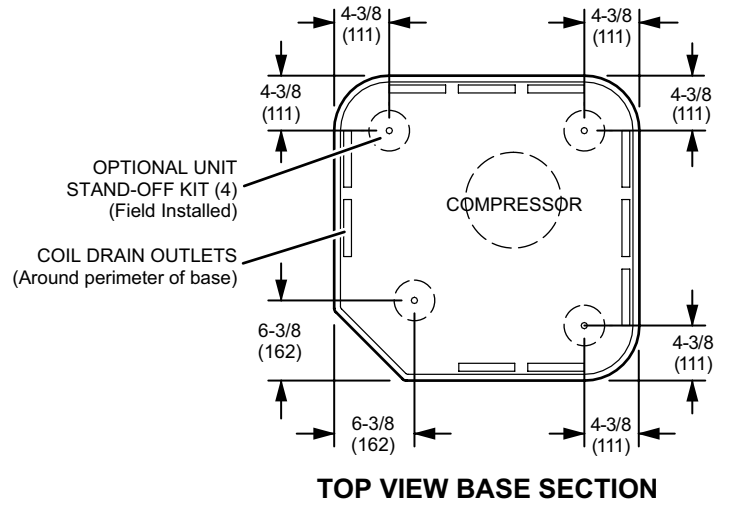
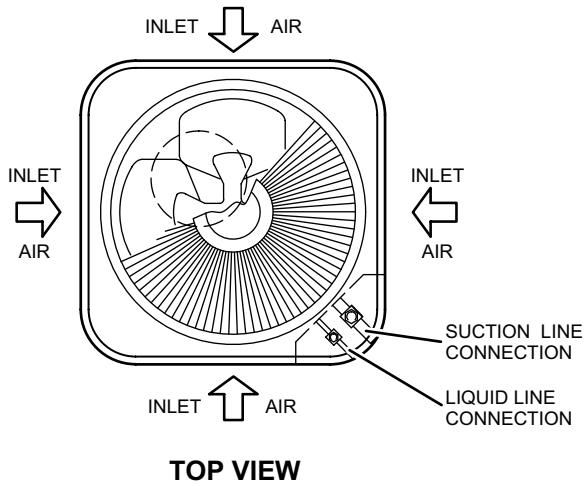

Size	A, B Width and Depth		C Height	
	inches	mm	inches	mm
018	24-1/4	616	25-1/4	641
024	24-1/4	616	29-1/4	743
030	28-1/4	718	29-1/4	743
036	28-1/4	718	33-1/4	845
042	28-1/4	718	37-1/4	946
048	28-1/4	718	29-1/4	743
060	28-1/4	718	37-1/4	946

FIELD WIRING

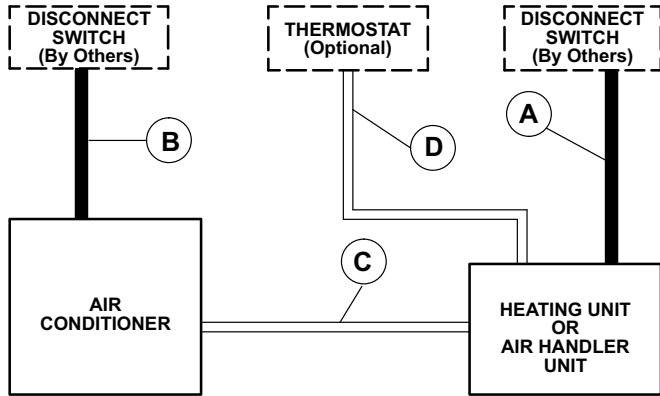

- A - Two Wire Power (not furnished). See Indoor Unit Electrical Data
- B - Two Wire Power (not furnished). See Electrical Data
- C - Four Wire Low Voltage (not furnished). 18 ga. minimum
- D - Five Wire Low Voltage (not furnished). 18 ga. minimum

All wiring must conform to NEC or CEC and local electrical codes.

INSTALLATION CLEARANCES

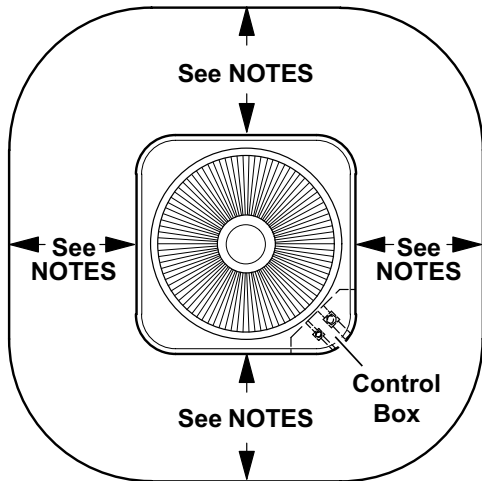

NOTES:

- Service Clearance – 30 in. (762 mm) must be maintained on one of the sides adjacent to the control box
- Clearance to one of other three sides must be 36 in. (914 mm).
- Clearance to one of the remaining two sides may be 12 in. (305 mm), and the final side may be 6 in. (152 mm).
- A clearance of 24 in. must be maintained between two units. 48 in. (1219 mm) clearance required on top of unit.

SOUND DATA

Size	Octave Band Sound Power Levels dBA, re 10 ⁻¹² Watts Center Frequency - HZ							¹ Sound Rating Number (dBA)	² Estimated Sound Pressure Level at Distance From Unit (dBA at distance in ft.)				
	125	250	500	1000	2000	4000	8000		3	5	10	15	50
018	53	58.5	66.5	69.5	65	62.5	54.5	73	66	61	55	52	41
024	56	66	72	71	67	63	56.5	76	69	64	58	55	44
030	55	64.5	70.5	72.5	67.5	61	54	76	69	64	58	55	44
036	58	67.5	71.5	70.5	66.5	61.5	55	76	69	64	58	55	44
042	56	65	71	71.5	67.5	62	55	76	69	64	58	55	44
048	61.5	68	73.5	72.5	69	64	56.5	78	71	66	60	57	46
060	63.5	70	75	75	70.5	68	61	80	73	68	62	59	48

NOTE - the octave sound power data does not include tonal correction.

¹ Tested according to AHRI Standard 270-2008 test conditions.

² Estimated sound pressure level at distance based on AHRI Standard 275-2010 method for equipment located on the ground, roof, or on side of building wall with no adjacent reflective surface within 9.8 feet. Sound pressure levels will increase based on changes to assumptions. For other applications, refer to AHRI Standard 275.

TXV USAGE

All Allied coils and air handlers are shipped with a factory installed TXV. In most cases, no substitution is needed. If a different size TXV is required, it will be listed in the "TXV SUBSTITUTION" table by size. The correct TXV must be ordered separately and field installed.

Size	Order Number
018	26Z70
024	26Z70
030	26Z70
036	26Z70
042	26Z71
048	26Z71
060	26Z72

AHRI STANDARD 210-240-2023

Standard Ratings relating to cooling or heating capacities shall be net values, including the effects of circulating-fan heat, but not including supplementary electric heat. Power input used for calculating efficiency shall be the Total Power.

Standard Ratings of units which do not have indoor air-circulating fans furnished as part of the model, i.e., Coil-only System, shall be established by subtracting from the total cooling capacity 1,505 Btu/h per 1,000 SCFM, and by adding the same amount to the heating capacity for non-mobile-home, non-Space Constrained units. Total Power for both heating and cooling shall be increased by 441 W per 1,000 SCFM of indoor air circulated.

TXV SUBSTITUTION - R-454B

A general guide for replacing the factory installed R-454B TXV if the indoor unit (coil/air handler) is larger or smaller than the outdoor unit.

Outdoor Unit		Indoor Unit		Indoor TXV Furnished	Indoor TXV Replacement
Size	Tons	Size	Tons		
018	1.5	42	3.5	26Z71	26Z70
018	1.5	48	4	26Z71	26Z70
018	1.5	49	4	26Z71	26Z70
018	1.5	50/60	4/5	26Z71	26Z70
018	1.5	51/61	4/5	26Z71	26Z70
018	1.5	60	5	26Z72	26Z70
024	2	42	3.5	26Z71	26Z70
024	2	48	4	26Z71	26Z70
024	2	49	4	26Z71	26Z70
024	2	50/60	4/5	26Z71	26Z70
024	2	51/61	4/5	26Z71	26Z70
024	2	60	5	26Z72	26Z70
030	2.5	42	3.5	26Z71	26Z70
030	2.5	48	4	26Z71	26Z70
030	2.5	49	4	26Z71	26Z70
030	2.5	50/60	4/5	26Z71	26Z70
030	2.5	51/61	4/5	26Z71	26Z70
030	2.5	60	5	26Z71	26Z70
036	3	42	3.5	26Z71	26Z70
036	3	48	4	26Z71	26Z70
036	3	49	4	26Z71	26Z70
036	3	50/60	4/5	26Z71	26Z70
036	3	51/61	4/5	26Z71	26Z70
036	3	60	5	26Z72	26Z70
042	3.5	24	2	26Z70	26Z71
042	3.5	30	2.5	26Z70	26Z71
042	3.5	30/36	2.5/3	26Z70	26Z71
042	3.5	36	3	26Z70	26Z71
042	3.5	60	5	26Z72	26Z71
048	4	30/36	2.5/3	26Z70	26Z71
048	4	36	3	26Z70	26Z71
048	4	60	5	26Z72	26Z71
060	5	50/60	4/5	26Z71	26Z72
060	5	51/61	4/5	26Z71	26Z72

TXV Ranges:

26Z70 - 1.5 to 3 ton systems - Use on 3 ton (036) and lower systems.

26Z71 - 3.5-4 ton systems - Use on to 4 ton (048) and down to 3.5 ton (042) systems.

26Z72 - 5 ton systems - Use on 5 ton (060) systems only.

COOLING PERFORMANCE EXTENDED RATINGS

BA713S30P - BC730[C,U]BT

Outdoor	Indoor	Outdoor Air Temperature Entering Outdoor Coil																				
		85° F (29.4° C)				95° F (35° C)				105° F (40.6° C)				115° F (46.1° C)				125° F (51.7° C)				
		Total Air Volume	Comp. Motor Input	Total Cooling Capacity	Sensible To Total Ratio (S/T)	Comp. Motor Input	Total Cooling Capacity	Sensible To Total Ratio (S/T)	Dry Bulb	Comp. Motor Input	Total Cooling Capacity	Sensible To Total Ratio (S/T)	Dry Bulb	Comp. Motor Input	Total Cooling Capacity	Sensible To Total Ratio (S/T)	Dry Bulb	Comp. Motor Input	Total Cooling Capacity	Sensible To Total Ratio (S/T)	Dry Bulb	
		cfm	kWh	75°F 23.9°C	80°F 26.7°C	85°F 29.4°C	75°F 23.9°C	80°F 26.7°C	85°F 29.4°C	75°F 23.9°C	80°F 26.7°C	85°F 29.4°C	75°F 23.9°C	80°F 26.7°C	85°F 29.4°C	75°F 23.9°C	80°F 26.7°C	85°F 29.4°C	75°F 23.9°C	80°F 26.7°C	85°F 29.4°C	
		880	29	1.66	0.92	1	277	1.88	0.94	1	265	2.13	0.98	1	253	2.41	0.97	1	239	2.72	0.92	1
	59°F (15°C)	1000	30.2	1.67	0.96	1	29	1.9	0.99	1	276	2.14	1	262	2.42	0.97	1	25	2.74	0.92	1	
		1130	31.4	1.68	1	1	30	1.91	1	1	28.5	2.16	1	27.2	2.43	0.97	1	25.7	2.75	0.92	1	
	63°F (17.2°C)	880	30.2	1.67	0.74	0.88	1	28.6	1.89	0.76	0.91	2.14	0.78	0.94	1	25.5	2.41	0.8	23.9	2.72	0.83	1
		1000	31.1	1.68	0.77	0.92	1	29.5	1.9	0.79	0.95	2.14	0.82	0.99	1	26.2	2.42	0.84	24.9	2.74	0.88	1
	67°F (19.4°C)	1130	31.8	1.69	0.8	0.96	1	30.2	1.91	0.82	0.99	2.16	0.85	1	27.1	2.43	0.88	25.7	2.75	0.92	1	
		880	32.1	1.69	0.58	0.72	0.85	30.6	1.92	0.59	0.73	2.16	0.6	0.75	0.9	27.3	2.43	0.62	25.6	2.75	0.63	0.8
	71°F (21.7°C)	1000	32.9	1.7	0.6	0.75	0.89	31.2	1.92	0.62	0.77	2.17	0.63	0.79	0.95	27.9	2.45	0.64	26.2	2.76	0.66	0.85
		1130	33.4	1.71	0.62	0.78	0.93	31.8	1.93	0.64	0.81	2.18	0.65	0.83	1	28.5	2.45	0.67	26.8	2.77	0.69	0.89
		880	33.6	1.71	0.45	0.57	0.69	32.1	1.93	0.45	0.58	2.18	0.45	0.59	0.73	29	2.46	0.46	27.3	2.78	0.46	0.62
		1000	34.6	1.72	0.45	0.59	0.73	33.1	1.95	0.46	0.6	2.2	0.46	0.62	0.77	29.7	2.48	0.47	28	2.79	0.48	0.65
		1130	35.3	1.73	0.47	0.61	0.76	33.7	1.96	0.47	0.63	2.21	0.48	0.64	0.8	30.3	2.49	0.48	28.6	2.8	0.5	0.68

BA713S36P - BC736[C,U]BT

Outdoor	Indoor	Outdoor Air Temperature Entering Outdoor Coil																				
		85° F (29.4° C)				95° F (35° C)				105° F (40.6° C)				115° F (46.1° C)				125° F (51.7° C)				
		Total Air Volume	Comp. Motor Input	Total Cooling Capacity	Sensible To Total Ratio (S/T)	Comp. Motor Input	Total Cooling Capacity	Sensible To Total Ratio (S/T)	Dry Bulb	Comp. Motor Input	Total Cooling Capacity	Sensible To Total Ratio (S/T)	Dry Bulb	Comp. Motor Input	Total Cooling Capacity	Sensible To Total Ratio (S/T)	Dry Bulb	Comp. Motor Input	Total Cooling Capacity	Sensible To Total Ratio (S/T)	Dry Bulb	
		cfm	kWh	75°F 23.9°C	80°F 26.7°C	85°F 29.4°C	75°F 23.9°C	80°F 26.7°C	85°F 29.4°C	75°F 23.9°C	80°F 26.7°C	85°F 29.4°C	75°F 23.9°C	80°F 26.7°C	85°F 29.4°C	75°F 23.9°C	80°F 26.7°C	85°F 29.4°C	75°F 23.9°C	80°F 26.7°C	85°F 29.4°C	
		1050	34.4	1.98	0.93	1	33.2	2.25	0.95	1	31.9	2.57	0.97	1	30.5	2.94	0.94	28.8	3.37	0.82	1	
	59°F (15°C)	1200	35.8	1.99	0.97	1	34.6	2.26	0.99	1	33	2.57	1	31.7	2.93	0.84	30.1	3.36	0.87	1		
		1350	37.1	1.99	1	1	35.6	2.26	1	1	34.2	2.57	1	32.6	2.93	0.88	31	3.36	0.91	1		
	63°F (17.2°C)	1050	35.6	1.99	0.74	0.89	1	34.2	2.25	0.76	0.91	32.4	2.57	0.77	0.94	30.9	2.94	0.8	29.1	3.37	0.82	1
		1200	36.6	1.99	0.78	0.94	1	34.9	2.26	0.8	0.96	33.2	2.57	0.81	0.99	31.7	2.93	0.84	30.1	3.36	0.87	1
	67°F (19.4°C)	1350	37.4	2	0.81	0.98	1	35.7	2.26	0.83	1	34.2	2.57	0.85	1	32.7	2.93	0.88	31	3.36	0.91	1
		1050	37.7	2	0.59	0.72	0.86	36	2.26	0.59	0.74	34.5	2.57	0.6	0.75	32.7	2.93	0.61	31	3.36	0.63	0.8
		1200	38.6	2	0.61	0.76	0.9	37	2.27	0.62	0.77	35.2	2.57	0.63	0.79	33.4	2.93	0.64	31.5	3.35	0.65	0.85
		1350	39.3	2	0.63	0.79	0.94	37.6	2.27	0.64	0.81	36	2.58	0.65	0.83	34.1	2.93	0.66	32.2	3.36	0.69	0.89
	71°F (21.7°C)	1050	39.6	2	0.45	0.58	0.7	38.1	2.27	0.45	0.58	36.4	2.58	0.45	0.59	34.6	2.93	0.45	32.8	3.35	0.46	0.62
		1200	40.7	2.01	0.45	0.59	0.73	39	2.28	0.46	0.6	37.3	2.58	0.46	0.62	35.5	2.94	0.47	33.4	3.35	0.47	0.65
		1350	41.6	2.01	0.47	0.62	0.77	39.9	2.28	0.47	0.63	38.1	2.59	0.48	0.65	36.2	2.94	0.48	34	3.35	0.48	0.68

COOLING PERFORMANCE EXTENDED RATINGS

BA713S42P - BC749[C,U]CT

Outdoor	Indoor	Entering Wet Bulb Temperature	Outdoor Air Temperature Entering Outdoor Coil																																
			85° F (29.4° C)				95° F (35° C)				105° F (40.6° C)				115° F (46.1° C)				125° F (51.7° C)																
			Total Cooling Capacity	Comp. Motor Input	Sensible To Total Ratio (S/T)		Total Cooling Capacity	Comp. Motor Input	Sensible To Total Ratio (S/T)		Total Cooling Capacity	Comp. Motor Input	Sensible To Total Ratio (S/T)		Total Cooling Capacity	Comp. Motor Input	Sensible To Total Ratio (S/T)		Total Cooling Capacity	Comp. Motor Input	Sensible To Total Ratio (S/T)														
kBtuh	kW	75°F 23.9°C	80°F 26.7°C	85°F 29.4°C	kBtuh	kW	75°F 23.9°C	80°F 26.7°C	85°F 29.4°C	kBtuh	kW	75°F 23.9°C	80°F 26.7°C	85°F 29.4°C	kBtuh	kW	75°F 23.9°C	80°F 26.7°C	85°F 29.4°C	kBtuh	kW	75°F 23.9°C	80°F 26.7°C	85°F 29.4°C											
			cfm	1230	2.37	0.92	1	1	1	39.2	2.71	0.94	1	1	1	37.8	3.09	0.97	1	1	1	36.2	3.52	0.99	1	1	1	34.3	3.99	1	1	1	1		
		59°F (15°C)	1400	42.3	2.38	0.97	1	1	1	40.9	2.72	0.99	1	1	1	39.2	3.1	1	1	1	1	37.7	3.53	1	1	1	1	35.8	4	1	1	1	1		
			1580	43.8	2.39	1	1	1	1	42.3	2.73	1	1	1	1	40.5	3.11	1	1	1	1	38.9	3.54	1	1	1	1	37.1	4.01	1	1	1	1		
		63°F (17.2°C)	1230	42	2.38	0.75	0.89	1	1	40.4	2.72	0.76	0.91	1	1	38.6	3.1	0.78	0.93	1	1	36.6	3.52	0.8	0.96	1	1	34.6	3.99	0.82	0.99	1	1	1	
			1400	43.2	2.39	0.78	0.93	1	1	41.5	2.72	0.79	0.96	1	1	39.4	3.1	0.82	0.98	1	1	37.7	3.53	0.84	1	1	35.9	4	0.86	1	1	1	1	1	
		67°F (19.4°C)	1580	44.2	2.39	0.81	0.98	1	1	42.4	2.73	0.82	1	1	40.5	3.11	0.85	1	1	1	39	3.54	0.88	1	1	37.1	4.01	0.91	1	1	1	1	1	1	
			1230	44.3	2.39	0.59	0.72	0.86	0.94	42.6	2.73	0.6	0.74	0.88	40.5	3.11	0.61	0.76	0.9	0.95	39.8	3.54	0.62	0.77	0.93	36.7	4.01	0.63	0.8	0.96	1	1	1	1	
		71°F (21.7°C)	1400	45.5	2.4	0.61	0.76	0.9	0.94	43.8	2.74	0.62	0.77	0.92	41.6	3.12	0.63	0.79	0.95	0.98	39.8	3.54	0.64	0.81	0.98	37.3	4.01	0.66	0.84	1	1	1	1	1	
			1580	46.6	2.41	0.63	0.79	0.94	0.94	44.8	2.75	0.64	0.81	0.97	42.8	3.13	0.65	0.82	1	1	40.4	3.55	0.67	0.85	1	38	4.02	0.69	0.89	1	1	1	1	1	
			1230	46.4	2.41	0.45	0.58	0.7	0.74	44.7	2.75	0.45	0.58	0.72	42.6	3.12	0.45	0.6	0.73	0.78	40.5	3.55	0.46	0.61	0.75	38.3	4.02	0.46	0.62	0.77	1	1	1	1	1
		71°F (21.7°C)	1400	47.8	2.42	0.46	0.6	0.73	0.73	46	2.76	0.46	0.61	0.75	43.8	3.13	0.49	0.62	0.77	0.81	41.6	3.56	0.47	0.63	0.79	39.3	4.03	0.48	0.65	0.82	1	1	1	1	1
			1580	49	2.42	0.47	0.62	0.77	0.78	46.8	2.76	0.47	0.64	0.78	44.7	3.14	0.48	0.65	0.81	0.85	42.5	3.56	0.48	0.66	0.83	40.1	4.03	0.49	0.68	0.86	1	1	1	1	1

BA713S48P - BC760[C,U]CT

Outdoor	Indoor	Entering Wet Bulb Temperature	Outdoor Air Temperature Entering Outdoor Coil																															
			85° F (29.4° C)				95° F (35° C)				105° F (40.6° C)				115° F (46.1° C)				125° F (51.7° C)															
			Total Cooling Capacity	Comp. Motor Input	Sensible To Total Ratio (S/T)		Total Cooling Capacity	Comp. Motor Input	Sensible To Total Ratio (S/T)		Total Cooling Capacity	Comp. Motor Input	Sensible To Total Ratio (S/T)		Total Cooling Capacity	Comp. Motor Input	Sensible To Total Ratio (S/T)		Total Cooling Capacity	Comp. Motor Input	Sensible To Total Ratio (S/T)													
kBtuh	kW	75°F 23.9°C	80°F 26.7°C	85°F 29.4°C	kBtuh	kW	75°F 23.9°C	80°F 26.7°C	85°F 29.4°C	kBtuh	kW	75°F 23.9°C	80°F 26.7°C	85°F 29.4°C	kBtuh	kW	75°F 23.9°C	80°F 26.7°C	85°F 29.4°C	kBtuh	kW	75°F 23.9°C	80°F 26.7°C	85°F 29.4°C										
			cfm	1410	47.6	2.77	0.94	1	1	45.7	3.15	0.96	1	1	43.8	3.58	0.99	1	1	1	41.7	4.08	1	1	1	39.2	4.64	1	1	1	1	1	1	
		59°F (15°C)	1610	49.8	2.79	0.99	1	1	1	47.7	3.17	1	1	1	45.6	3.61	1	1	1	1	43.4	4.09	1	1	1	40.8	4.66	1	1	1	1	1	1	1
			1810	51.4	2.81	1	1	1	1	49.4	3.2	1	1	1	47.3	3.63	1	1	1	1	45	4.12	1	1	1	42.4	4.67	1	1	1	1	1	1	1
		63°F (17.2°C)	1410	48.9	2.78	0.77	0.91	1	1	46.5	3.16	0.78	0.94	1	44.3	3.59	0.8	0.96	1	1	41.8	4.08	0.83	0.99	1	39.2	4.64	0.86	1	1	1	1	1	1
			1610	50.4	2.79	0.81	0.96	1	1	47.9	3.17	0.82	0.99	1	45.7	3.61	0.84	1	1	1	43.4	4.09	0.87	1	1	40.9	4.66	0.91	1	1	1	1	1	1
		71°F (21.7°C)	1810	51.4	2.81	0.84	1	1	1	49.5	3.2	0.86	1	1	47.3	3.63	0.89	1	1	1	45	4.12	0.92	1	1	42.4	4.67	0.96	1	1	1	1	1	1
			1410	51.3	2.8	0.61	0.75	0.88	0.92	49.2	3.19	0.62	0.76	0.9	46.7	3.62	0.63	0.78	0.93	0.96	44.1	4.1	0.64	0.81	0.96	41.2	4.66	0.67	0.84	0.99	1	1	1	1
		67°F (19.4°C)	1610	52.7	2.82	0.63	0.79	0.93	0.93	50.5	3.21	0.63	0.8	0.95	47.9	3.64	0.65	0.82	0.99	0.99	45.3	4.12	0.67	0.85	1	42.2	4.67	0.69	0.89	1	1	1	1	1
			1810	54	2.83	0.64	0.82	0.98	0.98	51.5	3.22	0.67	0.84	1	49.1	3.65	0.68	0.87	1	1	46.3	4.13	0.7	0.9	1	43.1	4.68	0.73	0.94	1	1	1	1	1
			1410	54	2.83	0.47	0.6	0.72	0.72	51.8	3.22	0.47	0.6	0.74	49.3	3.66	0.47	0.62	0.76	0.76	46.7	4.14	0.48	0.64	0.78	43.3	4.68	0.49	0.65	0.81	1	1	1	1
		71°F (21.7°C)	1610	55.6	2.85	0.47	0.62	0.76	0.76	53.2	3.24	0.48	0.63	0.78	50.6	3.67	0.48	0.64	0.8	0.8	47.5	4.15	0.49	0.66	0.83	44.4	4.7	0.5	0.69	0.86	1	1	1	1
			1810	56.7	2.86	0.48	0.64	0.79	0.79	54.3	3.25	0.49	0.66	0.82	51.6	3.69	0.49	0.67	0.85	0.85	48.5	4.17	0.51	0.7	0.88	45.2	4.71	0.52	0.73	0.92	1	1	1	1

REVISIONS

Sections	Description of Change
Specifications	Added Refrigerant Line Set for 30 FT
Cooling Performance Extended Ratings	Added Extended Ratings data for the Cooling Performance



NOTE - Due to our ongoing commitment to quality, Specifications, Ratings and Dimensions subject to change without notice and without incurring liability. Improper installation, adjustment, alteration, service or maintenance can cause property damage or personal injury. Installation and service must be performed by a qualified installer and servicing agency.