

BH714

Single-Stage | R-454B | 1-Phase | 60Hz

RESIDENTIAL PRODUCT SPECIFICATIONS

1.5 to 5 Tons
SEER2 up to 17.0
HSPF2 up to 8.2



MODEL NUMBER IDENTIFICATION

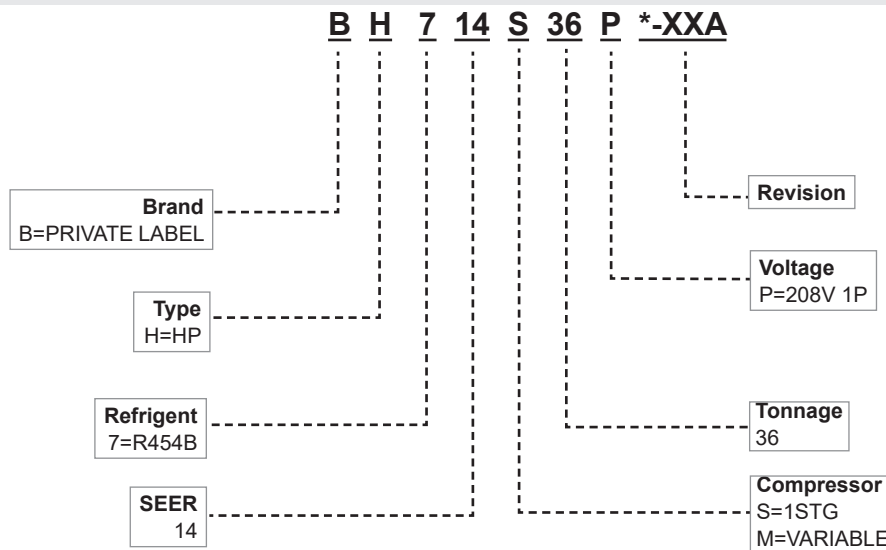

FEATURE HIGHLIGHTS

- Outdoor Coil Fan
- Condenser Coil
- CExpansion Valve - Outdoor Unit
- High Capacity Liquid Line Drier
- Four-Way Reversing Valve
- Scroll Compressor
- Defrost Control
- Heavy Gauge Steel Cabinet
- Refrigerant Line Access

CONTENTS

Model Number Identification	1
Approvals And Warranty	3
Features.	3
Controls - Order Separately.	5
Electrical Data	7
Optional Accessories - Order Separately	7
Specifications	7
Dimensions	8
Sound Data	9
Field Wiring	9
Installation Clearances	9
TXV Substitution	10
TXV Usage	10

APPROVALS AND WARRANTY

APPROVALS

- AHRI Standard 210-240-2023 certified
- AHRI Certified system match-ups and expanded ratings, visit www.alliedratings.com
- ENERGY STAR® certified
- Sound rated to AHRI Standard 270-2008 test conditions
- Rated According to U.S. Department of Energy (DOE) test procedures
- Unit and components ETL, NEC and CEC bonded for grounding to meet safety standards for servicing
- ETL certified (U.S. and Canada)
- ISO 9001 Registered Manufacturing Quality System

WARRANTY

10-years limited warranty on all parts, extended warranty available.

Coverage (Standard 5-year limited parts warranty plus an additional 5-year limited extended parts warranty).

Warranty must be registered online within 60 days of installation to qualify for 10-year coverage.

Unregistered equipment defaults to 5-year coverage.

See full warranty at www.alliedair.com for terms, conditions and exclusions.

FEATURES

APPLICATIONS

- 1.5 through 5 tons
- Single phase power supply
- Sound levels low as 74 dBA
- Vertical air discharge
- Applicable to indoor air handlers or gas furnaces with indoor add-on coils
- Shipped completely factory assembled, piped and wired

NOTE - When heat pumps are used with gas furnaces, a dual-fuel compatible thermostat or zone control system with dual-fuel capabilities must be used (order separately).

NOTE - Installer must set outdoor unit, connect refrigerant lines and make electrical connections to complete job.

REFRIGERATION SYSTEM

R-454B Refrigerant

- Low GWP (Global Warming Potential)
- Zero ODP (Ozone Depletion Potential)
- Low Toxicity/Lower Flammability - A2L
- Unit is factory pre-charged

NOTE - Total system refrigerant charge is dependent on outdoor unit size, indoor unit size and refrigerant line length.

NOTE - Refer to the unit-mounted charging sticker to determine correct amount of charge required.

Outdoor Coil Fan

- Direct drive PSC fan
- Vertical air discharge
- Louvered steel top fan guard
- Totally enclosed fan motor
- Ball bearings
- Inherently protected

Condenser Coil

- Enhanced aluminum alloy tube/enhanced fin coil
- Superior corrosion resistance
- Ripple-edged aluminum fins
- Aluminum tube construction
- Lanced fins for maximum fin surface exposure
- Fin collars grip tubing for maximum contact area
- Flared shoulder tubing connections
- Factory tested under high pressure
- Entire coil is accessible for cleaning

Expansion Valve - Outdoor Unit

- Designed and sized for heat pump systems
- Sensing bulb senses suction temperature during heating cycle

High Pressure Switch

- Protects the system from high pressure conditions
- Automatic reset

FEATURES

REFRIGERATION SYSTEM (continued)

Low Pressure Switch

- Shuts off unit if suction pressure falls below setting
- Loss of charge and freeze-up protection
- Automatic reset

High Capacity Liquid Line Drier

- Factory installed in the liquid line
- Drier traps moisture or dirt that could contaminate the system
- 100% molecular-sieve, bead type, bi-flow drier

Four-Way Reversing Valve

- Rapid changeover of refrigerant flow direction from cooling to heating and vice versa
- Operates on pressure differential between outdoor unit and indoor coil

Optional Accessories

Check/Expansion Valve Kits

- Field installed on indoor units (if required)
- See TXV Usage table
- Chatleff-style fitting

Loss of Charge Switch Kit

- Protects compressor from damage from low refrigerant charge conditions
- SPST, normally-closed
- Automatic reset

Freezestat

- Senses suction line temperature
- Cycles compressor off when suction line temperature falls below freezestat setpoint
- Opens at 29°F and closes at 58°F
- Installs on or near the discharge line of the evaporator or on the suction line

INDOOR REFRIGERANT DETECTION SYSTEM (RDS)

- Complies with UL 60335-2-40 approved standard
- Required for all systems using R-454B refrigerant
- Factory or field installed on all indoor units
- Consists of a RDS refrigerant detection sensor and a mitigation control in the indoor unit
- Ensures safe operation for systems equipped with R-454B refrigerant
- Indoor sensor will detect any R-454B refrigerant
- If R-454B refrigerant is detected, the refrigerant detection system will stop compressor operation and operate the blower to reduce concentrations in the conditioned space
- Once safe levels are reached the HVAC system will resume normal operation
- Refer to indoor unit Product Specifications documents for additional details

COMPRESSOR

Single-Stage Scroll Compressor

- High efficiency with uniform suction flow
- Constant discharge flow, high volumetric efficiency and quiet operation
- Low gas pulses during compression reduces operational sound levels
- Compressor motor is internally protected from excessive current and temperature
- Muffler in discharge line reduces operating sound levels
- Compressor is installed in the unit on resilient rubber mounts for vibration free operation

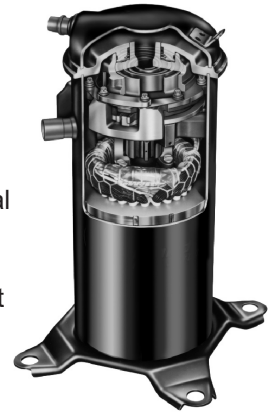

Scroll Compressor Operation

- Two involute spiral scrolls matched together generate a series of crescent-shaped gas pockets between them
- During compression, one scroll remains stationary while the other scroll orbits around it
- Gas is drawn into the outer pocket, the pocket is sealed as the scroll rotates
- As the spiral movement continues, gas pockets are pushed to the center of the scrolls. Volume between the pockets is simultaneously reduced
- When the pocket reaches the center, gas is now at high pressure and is forced out of a port located in the center of the fixed scrolls
- During compression, several pockets are compressed simultaneously resulting in a smooth continuous compression cycle
- Continuous flank contact, maintained by centrifugal force, minimizes gas leakage and maximizes efficiency
- Compressor is tolerant to the effects of slugging and contaminants. If this occurs, scrolls separate, allowing liquid or contaminants to be worked toward the center and discharged

Compressor Crankcase Heater (Factory installed on -036-042-048-060 models)

- Prevents migration of liquid refrigerant into compressor and ensures proper compressor lubrication

Optional Accessories

Compressor Crankcase Heater (Optional for -018-024-030 models)

- Prevents migration of liquid refrigerant into compressor and ensures proper compressor lubrication

Compressor Sound Cover

- Reinforced vinyl compressor cover
- 1-1/2 inch thick batt of fiberglass insulation
- Hook and loop fastening tape on all open edges

FEATURES

CONTROLS

Defrost Control

- Time/temperature defrost control
- Defrost cycle every 30, 60 or 90 minutes of compressor "on" time at outdoor coil temperatures below 42°F
- Factory setting - 90 minutes
- Anti-short cycle, timed-off control - 5 minutes
- Compressor delay - 30 seconds (field selectable) cycles the compressor in and out of defrost mode
- High and low pressure switch monitoring (five-trip lockout)
- Two diagnostic LEDs furnished for troubleshooting
- Conveniently located in control box

Optional Accessories

Remote Outdoor Temperature Sensor

- Outdoor sensor allows thermostat to display outdoor temperature

NOTE - Sensor is required for high and low balance points option.

Compressor Low Ambient Cut-Off

- Non-adjustable switch (low ambient cut-out)
- Prevents compressor operation in cooling mode when outdoor temperature is below 35°F

Compressor Hard Start Kit

- Single-phase units are equipped with a PSC compressor motor
- This type of motor normally does not need a potential relay and start capacitor
- For conditions such as low voltage, kit may be required to increase the compressor starting torque

Indoor Blower Off Delay Relay Kit

- Delays the indoor blower-off time during the cooling cycle

Low Ambient Kit

- Heat pump can operate in the cooling mode down to 45°F outdoor air temperature without additional controls
- Allows unit to operate properly down to 30°F in the cooling mode

NOTE - Crankcase heater and freezestat should be installed on compressors equipped with a low ambient kit.

NOTE - A compressor lock-out thermostat should be added to terminate compressor operation below recommended operation conditions.

Mild Weather Kit

- Units can operate in the heating mode at outdoor air temperatures up to 75°F
- Field installed kit allows heating operation above 75°F

Monitor Kit - Service Light

- Ambient compensating thermistor
- Service light thermostat
- For thermostats requiring indicator light inputs

Outdoor Thermostat Kit

- Outdoor thermostat locks out some of the electric heating elements on indoor units where two-stage control is applicable
- Outdoor thermostat maintains the heating load on low power input as long as possible before allowing the full power load to come on the line
- Thermostat Kit and Mounting Box must be ordered separately

CABINET

- Heavy gauge steel cabinet
- Pre-painted cabinet finish
- Louvered heavy gauge steel panels
- Control box conveniently located with all controls factory wired
- Corner patch plate allows compressor access
- Drainage holes provided in base section

Zinc-Coated Steel Unit Base

- Resists rust and corrosion

Refrigerant Line Connections, Electrical Inlets, Service Valves

- Sweat connection vapor and liquid lines
- Located on corner of unit cabinet
- Fully serviceable brass service valves
- Vapor valve can be fully shut off, while liquid valve may be front seated to manage refrigerant charge while servicing system
- Refrigerant line connections and field wiring inlets are located in one central area of cabinet for easy access
- See dimension drawing

Braze-Free/Press Fitting Flexibility

- Units can accommodate braze-free or press fittings for installation versatility

Optional Accessories

Unit Stand-Off Kit

- Black high density polyethylene feet
- Raises unit off mounting surface
- Four feet furnished per order number

SPECIFICATIONS

Size		018	024	030	036
Nominal Tonnage		1.5	2	2.5	3
Sound Rating Number	dBA	74	74	74	75
Connections	Liquid line (OD) - in.	3/8	3/8	3/8	3/8
(sweat)	Vapor line (OD) - in.	3/4	3/4	3/4	7/8
Refrigerant	¹ R-454B charge furnished	4 lbs. 7 oz.	5 lbs. 3 oz.	6 lbs. 7 oz.	7 lbs. 2 oz.
Indoor Unit Expansion Valve (TXV)		26Z70	26Z70	26Z70	26Z70
Outdoor Coil	Net face area - ft. ²	24.5	24.5	24.5	21.0
	Outer coil				
	Inner coil	---	---	---	20.3
	Tube diameter - in.	5/16	5/16	5/16	5/16
	Rows	1	1	1	2
	Fins - in.	22	22	22	22
Outdoor Fan	HP	1/6	1/6	1/6	1/6
	Diameter - in.	22	22	22	22
	Blades	3	3	3	3
	Cfm	2670	2670	2890	2870
	Rpm	867	867	847	839
	Watts	160	160	200	205
Shipping Data - lbs.		180	180	180	199

ELECTRICAL DATA

	Line voltage data (Volts-Phase-Hz)	208/230-1-60	208/230-1-60	208/230-1-60	208/230-1-60
	² Maximum overcurrent protection (MOCP) amps	15	20	25	35
	³ Minimum circuit ampacity (MCA)	9.7	13.6	16.6	22.2
Compressor	Rated Load Amps	7.2	10.3	12.5	16.7
	Locked Rotor Amps	47	60.2	67	93.5
Fan Motor	Full Load Amps	0.7	0.7	1.0	1.4

OPTIONAL ACCESSORIES - ORDER SEPARATELY

Compressor Crankcase Heater	93M04	•	•	•	Factory
Compressor Hard Start Kit	Copeland 10J42 LG 88M91	•	•	•	•
Compressor Sound Cover	18J42	•	•	•	•
Compressor Low Ambient Cut-Off	45F08	•	•	•	•
Freezestat	3/8 in. 93G35	•	•	•	•
Indoor Blower Off Delay Relay	58M81	•	•	•	•
Loss of Charge Kit	84M23	•	•	•	•
⁴Low Ambient Kit	54M89	•	•	•	•
Mild Weather Kit	11B97	•	•	•	•
Monitor Kit - Service Light	76F53	•	•	•	•
Outdoor Thermostat Kit	10Z23	•	•	•	•
Thermostat Mounting Box	31461	•	•	•	•
Unit Stand-Off Kit	94J45	•	•	•	•

NOTE - Extremes of operating range are plus 10% and minus 5% of line voltage.

¹ Refrigerant charge sufficient for 15 ft. length of refrigerant lines. For longer line set requirements see the Installation Instructions for information about line set length and additional refrigerant charge required.

² HACR type breaker or fuse.

³ Refer to National or Canadian Electrical Code manual to determine wire, fuse and disconnect size requirements.

⁴ Crankcase Heater and Freezestat are recommended with Low Ambient Kit.

SPECIFICATIONS

Size		042	048	060	
Nominal Tonnage		3.5	4	5	
Sound Rating Number	dBA	78	79	79	
Connections (sweat)	Liquid line (OD) - in.	3/8	3/8	3/8	
	Vapor line (OD) - in.	7/8	7/8	1-1/8	
² Refrigerant	¹ R-454B charge furnished	8 lbs. 5 oz.	8 lbs. 6 oz.	9 lbs. 6 oz.	
Indoor Unit Expansion Valve (TXV)		26Z71	26Z71	26Z72	
Outdoor Coil	Net face area - ft. ²	Outer coil	24.93	24.93	29.09
		Inner coil	24.13	24.13	28.16
	Tube diameter - in.	5/16	5/16	5/16	
	Rows	2	2	2	
	Fins - in.	22	22	22	
Outdoor Fan	HP	1/3	1/3	1/3	
	Diameter - in.	22	22	22	
	Blades	4	4	4	
	Cfm	4347	4347	4500	
	Rpm	843	843	830	
	Watts	299	299	307	
Shipping Data - lbs.		230.6	250.3	268	

ELECTRICAL DATA

	Line voltage data (Volts-Phase-Hz)	208/230-1-60	208/230-1-60	208/230-1-60
	² Maximum overcurrent protection (MOCP) amps	35	50	50
	³ Minimum circuit ampacity (MCA)	22.3	30.6	32.2
Compressor	Rated Load Amps	15.8	22.4	23.7
	Locked Rotor Amps	96	126	157
Fan Motor	Full Load Amps	2.6	2.6	2.6

OPTIONAL ACCESSORIES - ORDER SEPARATELY

Compressor Hard Start Kit	Copeland	10J42		•	•
	LG	88M91	•		
Compressor Low Ambient Cut-Off		45F08	•	•	•
Compressor Sound Cover		18J42	•	•	•
Freezestat	3/8 in.	93G35	•	•	•
Indoor Blower Off Delay Relay		58M81	•	•	•
Loss of Charge Kit		84M23	•	•	•
⁴ Low Ambient Kit		54M89	•	•	•
Mild Weather Kit		11B97	•	•	•
Monitor Kit - Service Light		76F53	•	•	•
Outdoor Thermostat Kit		10Z23	•	•	•
Thermostat Mounting Box		31461	•	•	•
Unit Stand-Off Kit		94J45	•	•	•

NOTE - Extremes of operating range are plus 10% and minus 5% of line voltage.

¹ Refrigerant charge sufficient for 15 ft. length of refrigerant lines. For longer line set requirements see the Installation Instructions for information about line set length and additional refrigerant charge required.

² HACR type breaker or fuse.

³ Refer to National or Canadian Electrical Code manual to determine wire, fuse and disconnect size requirements.

⁴ Crankcase Heater and Freezestat are recommended with Low Ambient Kit.

DIMENSIONS

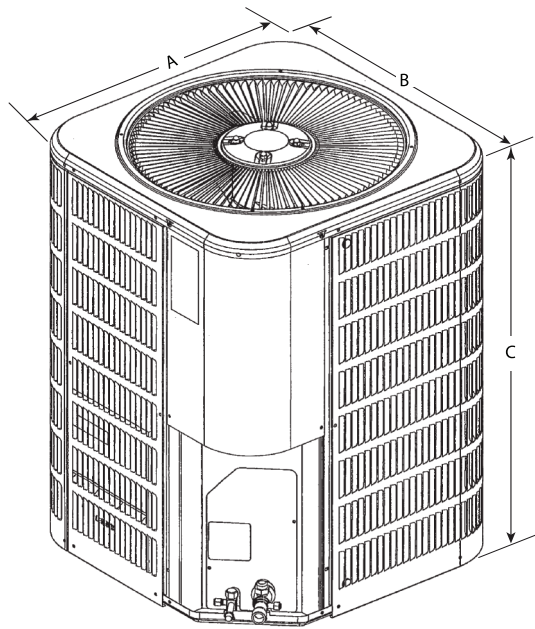
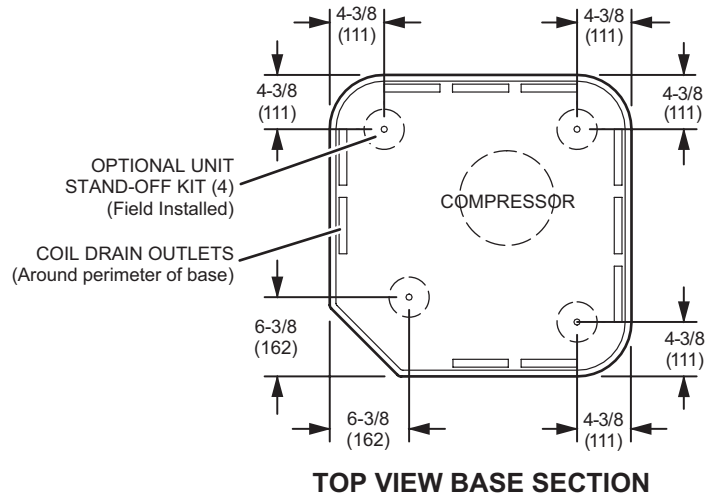
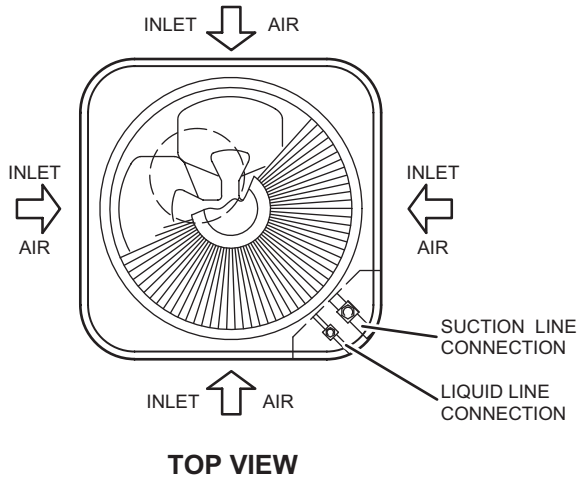

Size	A, B Width and Depth		C Height	
	in.	mm	in.	mm
018	28-1/4	718	43-1/4	1099
024	28-1/4	718	43-1/4	1099
030	28-1/4	718	33-1/4	845
036	32-1/4	819	33-1/4	845
042	32-1/4	819	37-1/4	946
048	32-1/4	819	37-1/4	946
060	32-1/4	819	43-1/4	1099

EXPANDED SOUND DATA

Size	Octave Band Sound Power Levels dBA, re 10 ⁻¹² Watts Center Frequency - HZ							¹ Sound Rating Number (dBA)	² Estimated Sound Pressure Level at Distance From Unit (dBA at distance in ft.)				
	125	250	500	1000	2000	4000	8000		3	5	10	15	50
018	56.5	62	68.0	71.5	66.0	57.0	50	74	67	62	56	53	42
024	56.0	62	66.5	71.0	66	60	55.0	74	67	62	56	53	42
030	56.0	64	69.5	70.0	65	59	52.5	74	67	62	56	53	42
036	59	68	71.5	68.5	66	61	54	75	68	63	57	54	43
042	62	71.0	74.5	72.5	70	63	55.5	78	71	66	60	57	46
048	61	70.5	75.5	73.0	70	64	56.0	79	72	67	61	58	47
060	61.5	70.0	73.0	71	71	68	63	79	73	68	62	59	48

NOTE - the octave sound power data does not include tonal correction.

¹ Tested according to AHRI Standard 270-2008 test conditions.

² Estimated sound pressure level at distance based on AHRI Standard 275-2010 method for equipment located on the ground, roof, or on side of building wall with no adjacent reflective surface within 9.8 feet. Sound pressure levels will increase based on changes to assumptions. For other applications, refer to AHRI Standard 275.

FIELD WIRING

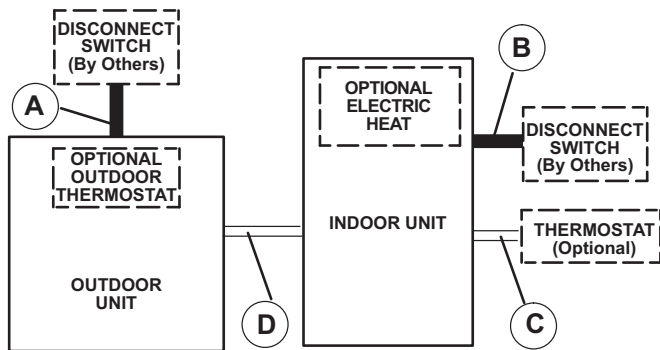

A - Two Wire Power (see Electrical Data)

B - Two or Three Wire Power (size to heater capacity)

C - Twelve Wire Low Voltage 18 ga. minimum
Fourteen Wire Low Voltage with Optional Outdoor Thermostat

D - Eight Wire Low Voltage 18 ga. minimum
Ten Wire Low Voltage with Optional Outdoor Thermostat

NOTE - Field Wiring Not Furnished

All wiring must conform to NEC or CEC and local electrical codes.

INSTALLATION CLEARANCES

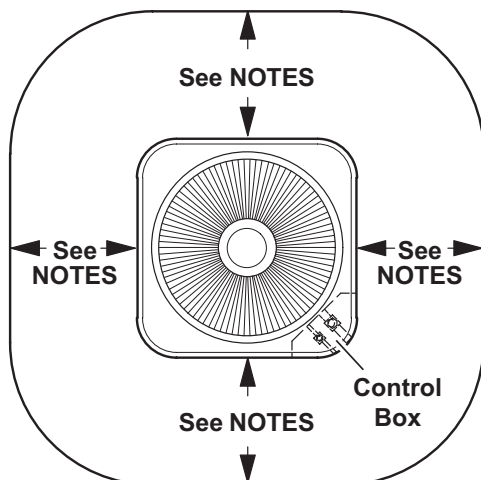

NOTES:

- Service Clearance – 30 in. (762 mm) on one of the sides adjacent to the Control Box.
- One of other three sides must be 36 in. (914 mm).
- One of the two remaining sides may be 12 in. (305 mm).
- The remaining side may be 6 in. (152 mm).
- 48 in. (1219 mm) clearance required on top of unit
- 24 in. (610 mm) required between two units

TXV USAGE

All coils and air handlers are shipped with a factory installed TXV. In most cases, no substitution is needed. If a different size TXV is required, it will be listed in the "TXV SUBSTITUTION" table by size. The correct TXV must be ordered separately and field installed.

Size	Order Number
018	26Z70
024	26Z70
030	26Z70
036	26Z70
042	26Z71
048	26Z71
060	26Z72

AHRI STANDARD 210-240-2023

Cooling or heating capacities are net values, including the effects of blower motor heat, and do not include supplementary heat. Power input is the total power input to the compressor(s) and fan(s), plus any controls and other items required as part of the system for normal operation.

Units which do not have an indoor air-circulating blower furnished as part of the model, i.e., split system with indoor coil only, is established by subtracting from the total cooling capacity 1250 Btu/h per 1,000 cfm, and by adding the same amount to the heating capacity.

Total power input for both heating and cooling is increased by 365 W per 1,000 cfm of indoor air circulated.

TXV SUBSTITUTION - R-454B

A general guide for replacing the factory installed R-454B TXV if the indoor unit (coil/air handler) is larger or smaller than the outdoor unit.

Outdoor Unit		Indoor Unit		Indoor TXV Furnished	Indoor TXV Replacement
Size	Tons	Size	Tons		
018	1.5	42	3.5	26Z71	26Z70
018	1.5	48	4	26Z71	26Z70
018	1.5	49	4	26Z71	26Z70
018	1.5	50/60	4/5	26Z71	26Z70
018	1.5	51/61	4/5	26Z71	26Z70
018	1.5	60	5	26Z72	26Z70
024	2	42	3.5	26Z71	26Z70
024	2	48	4	26Z71	26Z70
024	2	49	4	26Z71	26Z70
024	2	50/60	4/5	26Z71	26Z70
024	2	51/61	4/5	26Z71	26Z70
024	2	60	5	26Z72	26Z70
030	2.5	42	3.5	26Z71	26Z70
030	2.5	48	4	26Z71	26Z70
030	2.5	49	4	26Z71	26Z70
030	2.5	50/60	4/5	26Z71	26Z70
030	2.5	51/61	4/5	26Z71	26Z70
030	2.5	60	5	26Z72	26Z70
036	3	42	3.5	26Z71	26Z70
036	3	48	4	26Z71	26Z70
036	3	49	4	26Z71	26Z70
036	3	50/60	4/5	26Z71	26Z70
036	3	51/61	4/5	26Z71	26Z70
036	3	60	5	26Z72	26Z70
042	3.5	24	2	26Z70	26Z71
042	3.5	30	2.5	26Z70	26Z71
042	3.5	30/36	2.5/3	26Z70	26Z71
042	3.5	36	3	26Z70	26Z71
042	3.5	60	5	26Z72	26Z71
048	4	30/36	2.5/3	26Z70	26Z71
048	4	36	3	26Z70	26Z71
048	4	60	5	26Z72	26Z71
060	5	50/60	4/5	26Z71	26Z72
060	5	51/61	4/5	26Z71	26Z72

TXV Ranges:

26Z70 - 1.5 to 3 ton systems - Use on 3 ton (036) and lower systems.

26Z71 - 3.5-4 ton systems - Use on 4 ton (048) and down to 3.5 ton (042) systems.

26Z72 - 5 ton systems - Use on 5 ton (060) systems only.



Visit us at www.alliedair.com

Contact us at 1-800-448-5872

NOTE - Due to our ongoing commitment to quality, Specifications, Ratings and Dimensions subject to change without notice and without incurring liability. Improper installation, adjustment, alteration, service or maintenance can cause property damage or personal injury. Installation and service must be performed by a qualified installer and servicing agency.