

SUBMITTAL DATA SHEET

High Wall Heat Pump System BDS1A24SC0-BDS1A24WM0

Location:	Approval:
Engineer:	Date:
Submitted to:	Construction:
Submitted by:	Unit #:
Reference:	Drawing #:



INDOOR SPECIFICATION

Indoor Air Flow (Turbo/H/M/L/Si) (CFM)	729.9 / 547.4 / 400.2 / 329.6 / /	
Indoor Noise Level (Turbo/H/M/L/Si) (dBA)	51.5/45.5/40.5/26.5/21.5	
Dimension (W×D×H)	inch	42.60 x 9.21 x 13.27
	mm	1082×234×337
Package (W×D×H)	inch	45.47 x 16.34 x 12.40
	mm	1155×415×315
Net/Gross Weight	lbs	35.49/49.60
	kg	16.1/22.5

OUTDOOR SPECIFICATION

Compressor Type	ROTARY	
Compressor Model	KTM240D46UKT2	
Refrigerant	R454B	
Refrigerant Oil Charge(mL)	620	
Refrigerant Oil	9.3	
Outdoor Air Flow (Max) (CFM)	1765.8	
Outdoor Noise Level (dBA)	61	
Dimension (W×D×H)	inch	35.04 x 13.46 x 26.50
	mm	890×342×673
Package (W×D×H)	inch	39.17 x 15.67 x 29.13
	mm	995×398×740
Net/Gross Weight	lbs	95.90/117.73
	kg	43.5/53.4

EFFICIENCY

Cooling		Heating	
SEER2	18.9	HSPF2-4	8.7
EER2	9.7	COP	3.20

PERFORMANCE of Cooling

Cooling (Btu/hr)	
Rated Capacity	24000
Min/Max Capacity	6000~26500
Moisture Removal(L/h)	3.11
Standard Operating Range(°F/°C)	-13~122(-15~50)
Conditions:	Indoor: 80°F DB/67°F WB Outdoor: 95°F DB/75°F WB

PERFORMANCE of Heating

Heating (Btu/hr)	
1. @ 47°F Rated	25000
1. @ 47°F Min/Max Capacity	6200~28300
2. @ 17°F Rated	16300
3. @ 5°F Rated: Capacity / COP	17000/2.08
3. @ 5°F Max: Capacity	16100
Standard Operating Range(°F/°C)	-13~75(-25~24)
1. Conditions:	Indoor: 70°F DB/60°F WB Outdoor: 47°F DB/43°F WB
2. Conditions:	Indoor: 70°F DB/60°F WB Outdoor: 17°F DB/15°F WB
3. Conditions:	Indoor: 70°F DB/60°F WB Outdoor: 5°F DB/5°F WB

ELECTRICAL

Power Supply	208/230V,60Hz,1Ph	
System MCA	19	
Connection Wiring	14#x4	
System MOCP	20	
Compressor RLA	13.8	
Outdoor Fan Motor RLA	0.8	
Outdoor Fan Motor W	80	
Indoor Fan Motor RLA	0.6	
Indoor Fan Motor W	58	
System Power Input @ Cooling (W)	2474(540 ~ 2800)	
System Power Input @ Heating (W)	2290(410 ~2600)	
MCA: Min. circuit amps (A)	MOCP: Max. over current protection (A)	
RLA: Rated load amps (A)	W: Fan motor rated output (W)	

PIPING

Throttle type(Indoor)	N/A
Throttle type(Outdoor)	Throttle valve
Liquid Size	9.52mm(3/8in)
Gas Size	15.9mm(5/8in)
Max. Piping Length(ft/m)	164(50)
Max. Height Difference(ft/m)	82(25)
Max. Pre-charged Length(ft/m)	24.6(7.5)
Refrigerant Pre-charged Amount(oz/g)	50.44(1.43)
Additional Charge of Refrigerant((oz/ft)/(g/m))	0.32(30)
Connection Method	Flared

Indoor Unit Dimension

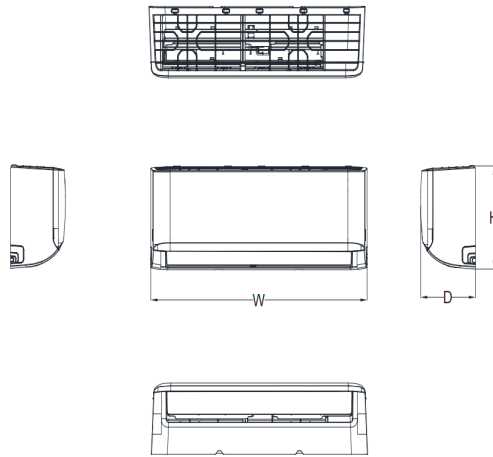

Capacity	Body Code	W(inch/mm)	D(mm/inch)	H(mm/inch)
6K~9K	A	28-3/4in /729mm	7-7/8in /200mm	11-1/2in /292mm
9K~12K	B	31-5/8in /802mm	7-7/8in /200mm	11-5/8in /295mm
18K	C	38-1/4in /971mm	9in/228mm	12-5/8in /321mm
18K~24K	D	42-5/8in /1082mm	9-1/4in/234mm	13-1/4in /337mm
30K~36K	F	49-5/8in /1259mm	11-1/8in/283mm	14-1/4in /362mm

Installation Instruction

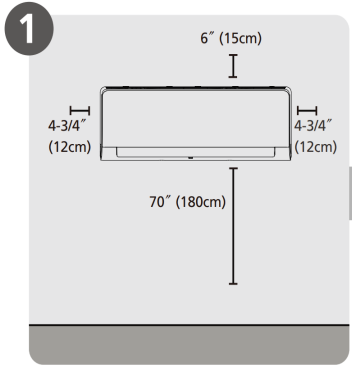

Select Installation Location

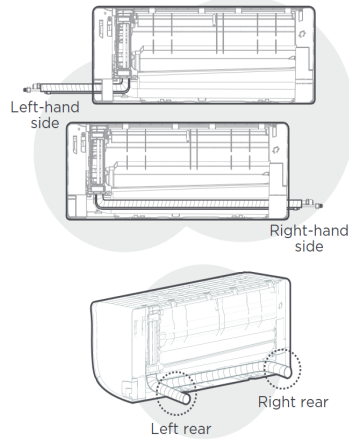

NOTE:
Based on the position of the wall hole relative to the mounting plate, choose the side from which the piping will exit the unit. You have four options for the exit direction of the piping.

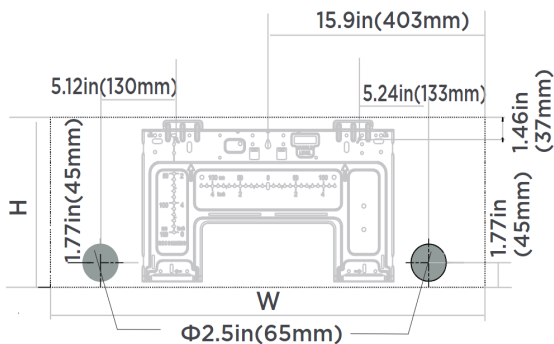

NOTE:
When the gas side connective pipe is Φ (5/8in)16mm or more, the wall hole should be (3-1/2in)90mm.

Indoor unit dimensions(WxH):
31.7in(806mm)x11.65in(296mm)

Outdoor Unit Dimension

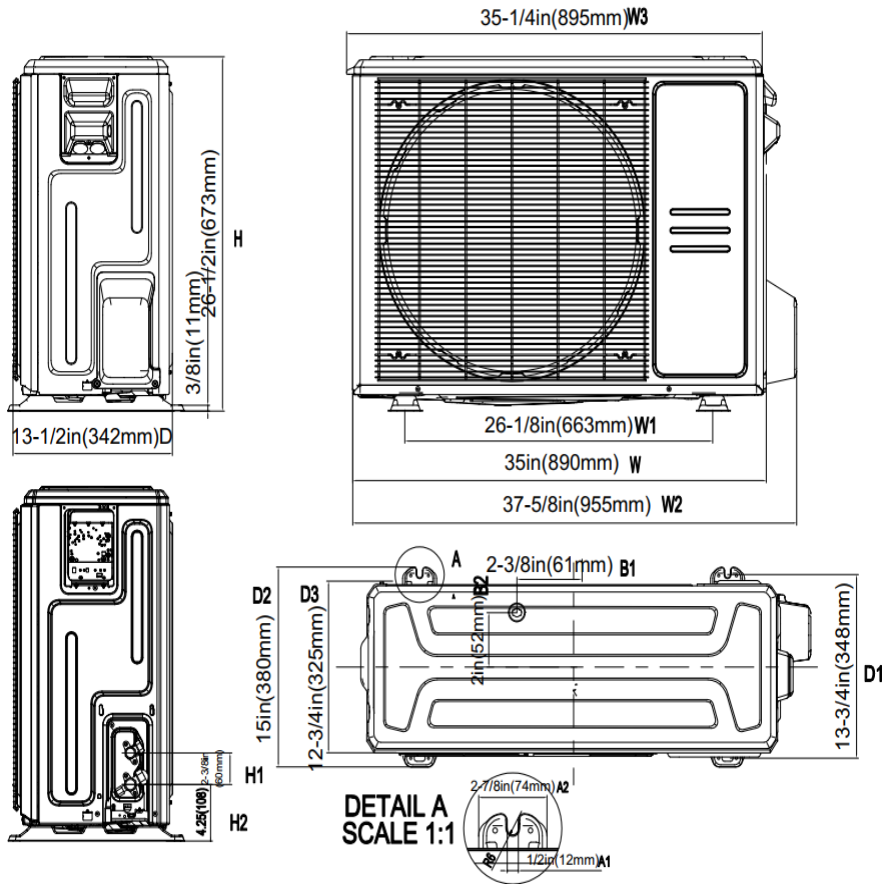

Installation Instruction

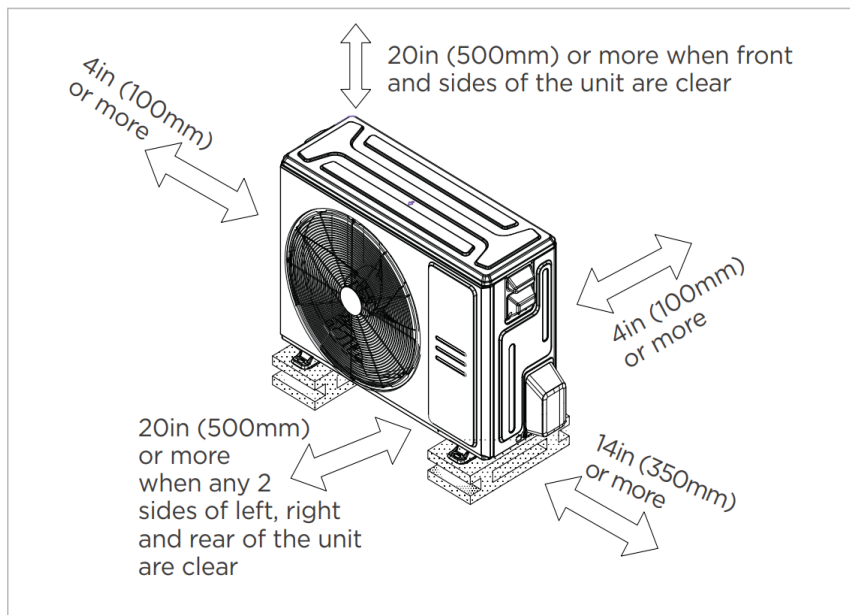

Meets all spatial requirements shown in Installation Clearance Requirements above.

FEATURES

- Indoor unit TU1 copper coil
- Humidity control
- 1~100% fan speed setting
- WiFi capability: through WiFi dongle or wired controller with built-in WiFi
- OTA(by using WiFi dongle)
- Multiple control options available:
 - Two way communication wired controller:120N(X6)
 - Two way communication wired controller with built-in WiFi:120N(X6W)
 - Infrared wired controller: 120L
 - Wireless remote controller
 - Third-Party 24V Thermostat*

*24V interface is required.