

SUBMITTAL DATA SHEET

High Wall Heat Pump System BDAFA18WM0-BDS2A18SC0

Location:	Approval:
Engineer:	Date:
Submitted to:	Construction:
Submitted by:	Unit #:
Reference:	Drawing #:



INDOOR SPECIFICATION

Indoor Air Flow (Turbo/H/M/L/Si) (CFM)	671.0 / 470.9 / 382.6 / 323.7 / /		
Indoor Noise Level (Turbo/H/M/L/Si) (dBA)	54.5/44.5/40.5/30.5/19.0		
Dimension (W×D×H)	inch	42.52 x 8.90 x 13.19	
	mm	1080×226×335	
Package (W×D×H)	inch	46.73 x 17.68 x 14.29	
	mm	1187×449×363	
Net/Gross Weight	lbs	35.49/49.60	
	kg	16.1/22.5	

OUTDOOR SPECIFICATION

Compressor Type	ROTARY		
Compressor Model	KSN140D58UFZ		
Refrigerant	R454B		
Refrigerant Oil Charge(mL)	440		
Refrigerant Oil	7.2		
Outdoor Air Flow (Max) (CFM)	3000		
Outdoor Noise Level (dBA)	58.5		
Dimension (W×D×H)	inch	35.04 x 13.46 x 26.50	
	mm	890×342×673	
Package (W×D×H)	inch	40.55 x 18.11 x 29.53	
	mm	1030×460×750	
Net/Gross Weight	lbs	93.48/114.20	
	kg	42.4/51.8	

EFFICIENCY

Cooling		Heating	
SEER2	22.5	HSPF2-4	11.5
EER2	13.7	COP	4.02

PERFORMANCE of Cooling

Cooling (Btu/hr)	
Rated Capacity	18000
Min/Max Capacity	7700~20600
Moisture Removal(L/h)	1.49
Standard Operating Range(°F/°C)	-13~122(-25~50)
Conditions:	Indoor: 80°F DB/67°F WB Outdoor: 95°F DB/75°F WB

PERFORMANCE of Heating

Heating (Btu/hr)	
1. @ 47°F Rated	18000
1. @ 47°F Min/Max Capacity	8100~22600
2. @ 17°F Rated	13400
3. @ 5°F Rated: Capacity / COP	12800/2.44
3. @ 5°F Max: Capacity	12800
Standard Operating Range(°F/°C)	-13~75(-25~24)
1. Conditions:	Indoor: 70°F DB/60°F WB Outdoor: 47°F DB/43°F WB
2. Conditions:	Indoor: 70°F DB/60°F WB Outdoor: 17°F DB/15°F WB
3. Conditions:	Indoor: 70°F DB/60°F WB Outdoor: 5°F DB/5°F WB

ELECTRICAL

Power Supply	208/230V,60Hz,1Ph
System MCA	18
Connection Wiring	14#x4
System MOCP	20
Compressor RLA	10.0
Outdoor Fan Motor RLA	0.9
Outdoor Fan Motor W	80
Indoor Fan Motor RLA	0.6
Indoor Fan Motor W	58
System Power Input @ Cooling (W)	1300(550 ~ 1690)
System Power Input @ Heating (W)	1280(405 ~ 1670)
MCA: Min. circuit amps (A)	MOCP: Max. over current protection (A)
RLA: Rated load amps (A)	W: Fan motor rated output (W)

PIPING

Throttle type(Indoor)	N/A
Throttle type(Outdoor)	EXV+Throttle valve
Liquid Size	6.35mm(1/4in)
Gas Size	12.7mm(1/2in)
Max. Piping Length(ft/m)	98.40(30)
Max. Height Difference(ft/m)	65.60(20)
Max. Pre-charged Length(ft/m)	24.6(7.5)
Refrigerant Pre-charged Amount(oz/g)	44.80(1.27)
Additional Charge of Refrigerant((oz/ft)/(g/m))	0.16(15)
Connection Method	Flared

Indoor Unit Dimension

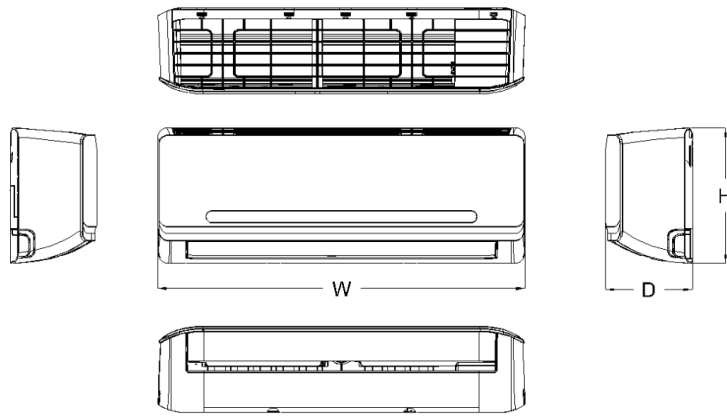

Capacity	Body Code	W(inch/mm)	D(inch/mm)	H(inch/mm)
9k Entry Tier Series	A	28-1/2in /722mm	7-3/8in /187mm	11-3/8in /290mm
9k~12k	B	31-1/2in /802mm	7-1/2in /189mm	11-3/4in /297mm
18k Entry Tier Series	D	38in /965mm	8-1/2in /215mm	12-1/2in /319mm
18k~24k	E	42-1/2in /1080mm	8-7/8in /226mm	13-1/4in /335mm
30k~36k	F	49-1/2in /1259mm	11-1/8in /282mm	14-1/4in /362mm

Installation Instruction

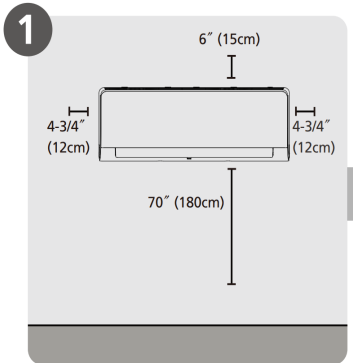

Select Installation Location

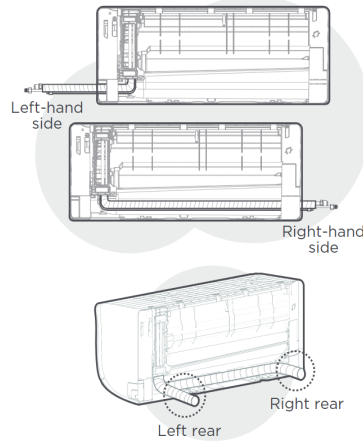

NOTE:
Based on the position of the wall hole relative to the mounting plate, choose the side from which the piping will exit the unit. You have four options for the exit direction of the piping.

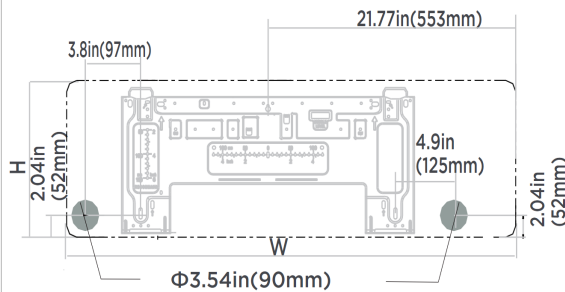

Indoor unit dimensions(WxH):
42.52in(1080mm)x13.19(335mm)

NOTE:
When the gas side connective pipe is Φ (5/8in)16mm or more, the wall hole should be (3-1/2in)90mm.

Outdoor Unit Dimension

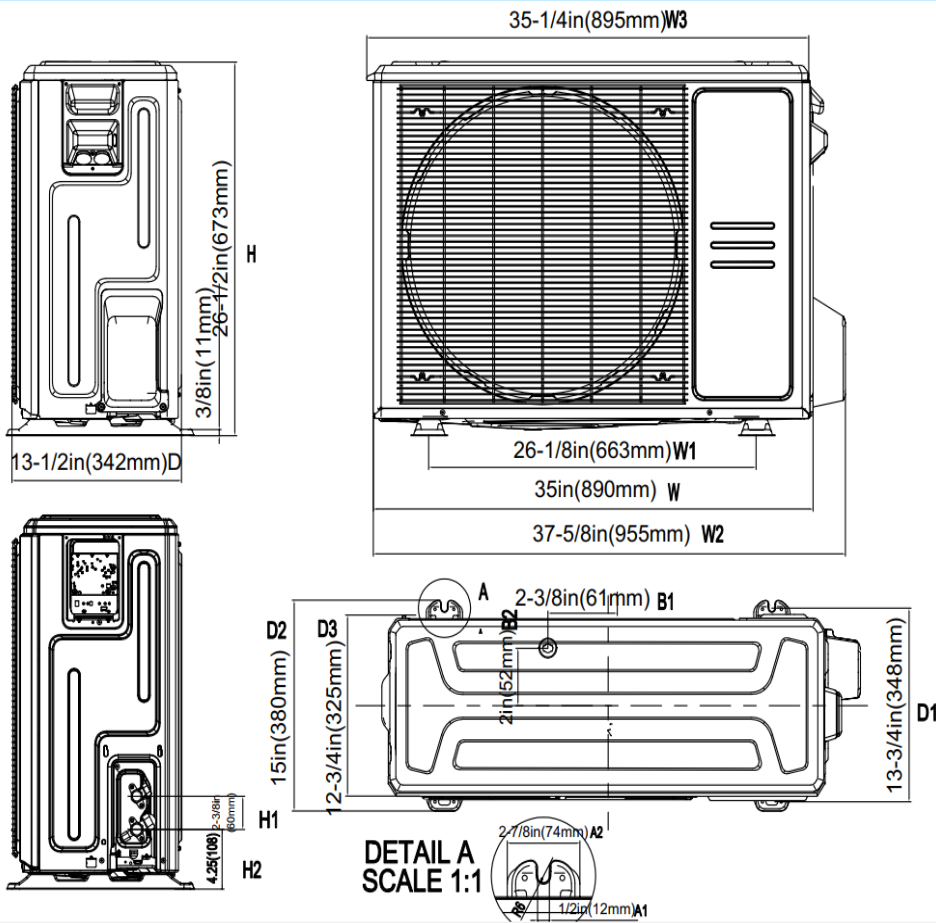

Installation Instruction

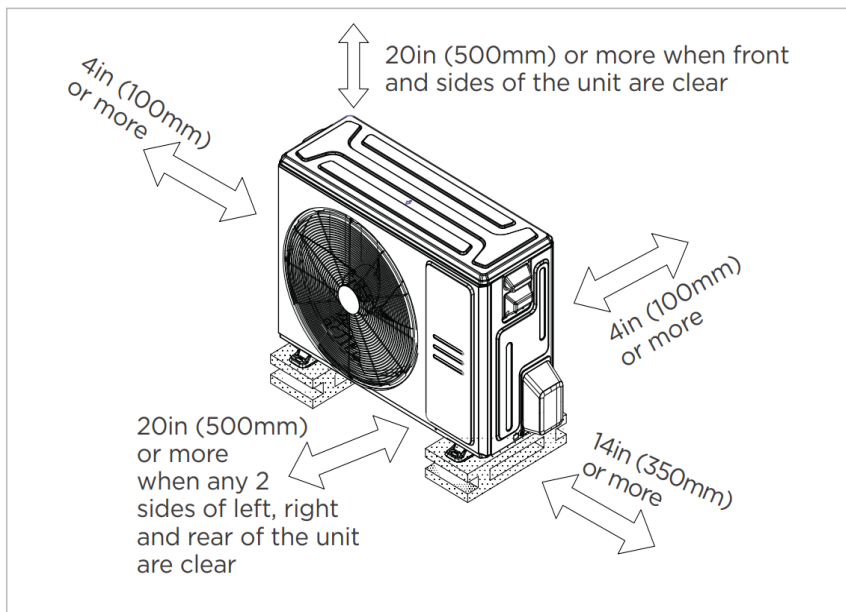

Meets all spatial requirements shown in Installation Clearance Requirements above.

FEATURES

- Indoor unit TU1 copper coil
- Humidity control
- 1~100% fan speed setting
- WiFi capability: through WiFi dongle or wired controller with built-in WiFi
- OTA(by using WiFi dongle)
- Multiple control options available:
 - Two way communication wired controller:120N(X6)
 - Two way communication wired controller with built-in WiFi:120N(X6W)
 - Infrared wired controller: 120L
 - Wireless remote controller
 - Third-Party 24V Thermostat*

*24V interface is required.