

SUBMITTAL DATA SHEET

High Wall Heat Pump System BDAFA24WM0-BDS2A24SC0

Location:	Approval:
Engineer:	Date:
Submitted to:	Construction:
Submitted by:	Unit #:
Reference:	Drawing #:



INDOOR SPECIFICATION

Indoor Air Flow (Turbo/H/M/L/Si) (CFM)	759.3 / 588.6 / 470.9 / 323.7 / /	
Indoor Noise Level (Turbo/H/M/L/Si) (dBA)	54.0/48.0/43.0/33.5/20.0	
Dimension (W×D×H)	inch	42.52 x 8.90 x 13.19
	mm	1080×226×335
Package (W×D×H)	inch	46.73 x 17.68 x 14.29
	mm	1187×449×363
Net/Gross Weight	lbs	35.93/49.82
	kg	16.3/22.6

OUTDOOR SPECIFICATION

Compressor Type	ROTARY	
Compressor Model	KTM240D46UKT2	
Refrigerant	R454B	
Refrigerant Oil Charge(mL)	620	
Refrigerant Oil	9.3	
Outdoor Air Flow (Max) (CFM)	3800	
Outdoor Noise Level (dBA)	58.5	
Dimension (W×D×H)	inch	37.24 x 16.14 x 31.89
	mm	946×410×810
Package (W×D×H)	inch	42.91 x 19.88 x 37.01
	mm	1090×505×940
Net/Gross Weight	lbs	122.80/155.64
	kg	55.7/70.6

EFFICIENCY

Cooling		Heating	
SEER2	22.7	HSPF2-4	9.5
EER2	12.7	COP	3.07

PERFORMANCE of Cooling

Cooling (Btu/hr)	
Rated Capacity	23000
Min/Max Capacity	6200~26200
Moisture Removal(L/h)	3.09
Standard Operating Range(°F/°C)	-13~122(-25~50)
Conditions:	Indoor: 80°F DB/67°F WB Outdoor: 95°F DB/75°F WB

PERFORMANCE of Heating

Heating (Btu/hr)	
1. @ 47°F Rated	23000
1. @ 47°F Min/Max Capacity	10300~28200
2. @ 17°F Rated	17900
3. @ 5°F Rated: Capacity / COP	15900/2.00
3. @ 5°F Max: Capacity	15900
Standard Operating Range(°F/°C)	-13~75(-25~24)
1. Conditions:	Indoor: 70°F DB/60°F WB Outdoor: 47°F DB/43°F WB
2. Conditions:	Indoor: 70°F DB/60°F WB Outdoor: 17°F DB/15°F WB
3. Conditions:	Indoor: 70°F DB/60°F WB Outdoor: 5°F DB/5°F WB

ELECTRICAL

Power Supply	208/230V,60Hz,1Ph	
System MCA	24	
Connection Wiring	14#x4	
System MOCP	25	
Compressor RLA	15.4	
Outdoor Fan Motor RLA	1.0	
Outdoor Fan Motor W	120	
Indoor Fan Motor RLA	0.8	
Indoor Fan Motor W	58	
System Power Input @ Cooling (W)	2000(650 ~ 2500)	
System Power Input @ Heating (W)	2400(640 ~2940)	
MCA: Min. circuit amps (A)	MOCP: Max. over current protection (A)	
RLA: Rated load amps (A)	W: Fan motor rated output (W)	

PIPING

Throttle type(Indoor)	N/A	
Throttle type(Outdoor)	EXV+Throttle valve	
Liquid Size	9.52mm(3/8in)	
Gas Size	15.9mm(5/8in)	
Max. Piping Length(ft/m)	164(50)	
Max. Height Difference(ft/m)	82(25)	
Max. Pre-charged Length(ft/m)	24.6(7.5)	
Refrigerant Pre-charged Amount(oz/g)	67.37(1.91)	
Additional Charge of Refrigerant((oz/ft)/(g/m))	0.32(30)	
Connection Method	Flared	

Indoor Unit Dimension

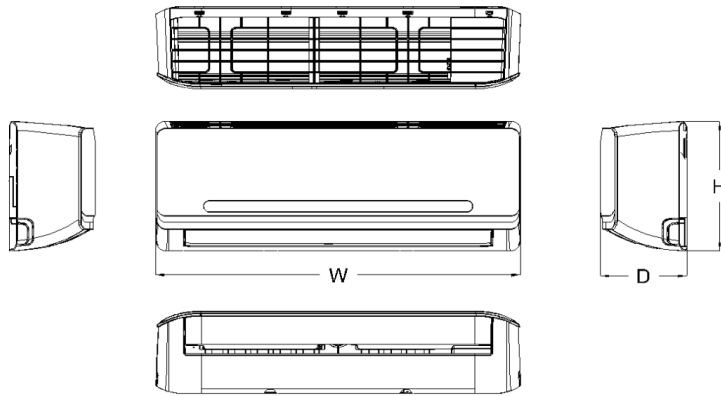

Capacity	Body Code	W(inch/mm)	D(inch/mm)	H(inch/mm)
9k Entry Tier Series	A	28-1/2in /722mm	7-3/8in /187mm	11-3/8in /290mm
9k~12k	B	31-1/2in /802mm	7-1/2in /189mm	11-3/4in /297mm
18k Entry Tier Series	D	38in /965mm	8-1/2in /215mm	12-1/2in /319mm
18k~24k	E	42-1/2in /1080mm	8-7/8in /226mm	13-1/4in /335mm
30k~36k	F	49-1/2in /1259mm	11-1/8in /282mm	14-1/4in /362mm

Installation Instruction

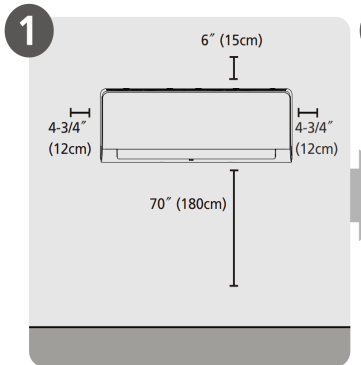

Select Installation Location

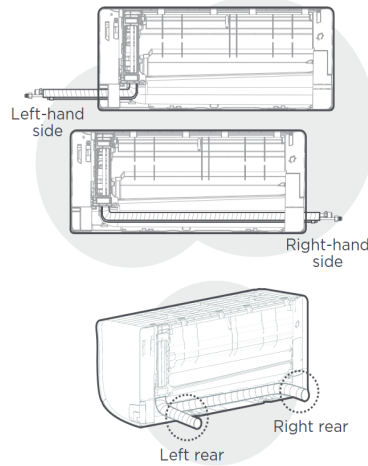

NOTE:
Based on the position of the wall hole relative to the mounting plate, choose the side from which the piping will exit the unit. You have four options for the exit direction of the piping.

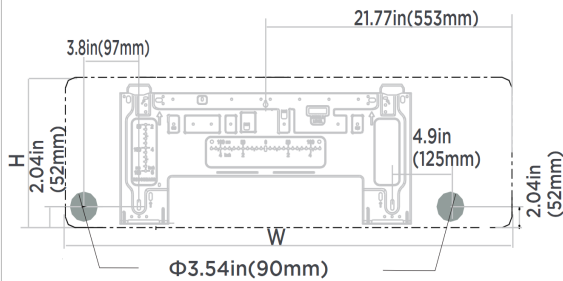

Indoor unit dimensions(WxH):
42.52in(1080mm)x13.19(335mm)

NOTE:
When the gas side connective pipe is Φ (5/8in)16mm or more, the wall hole should be (3-1/2in)90mm.

Outdoor Unit Dimension

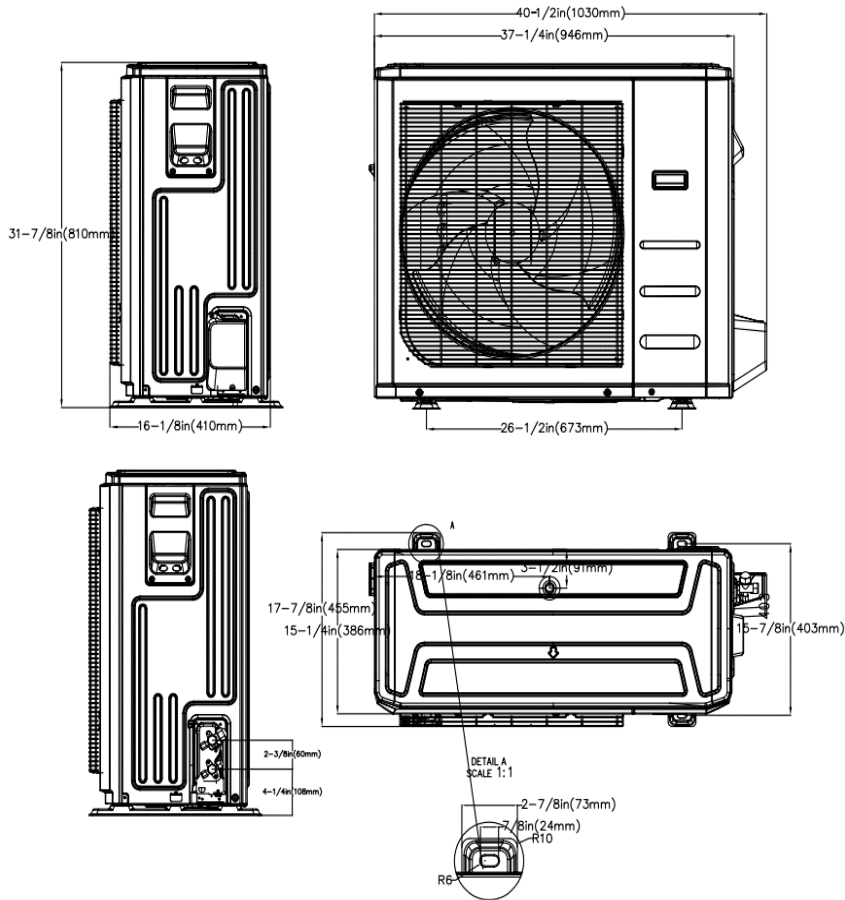

Installation Instruction

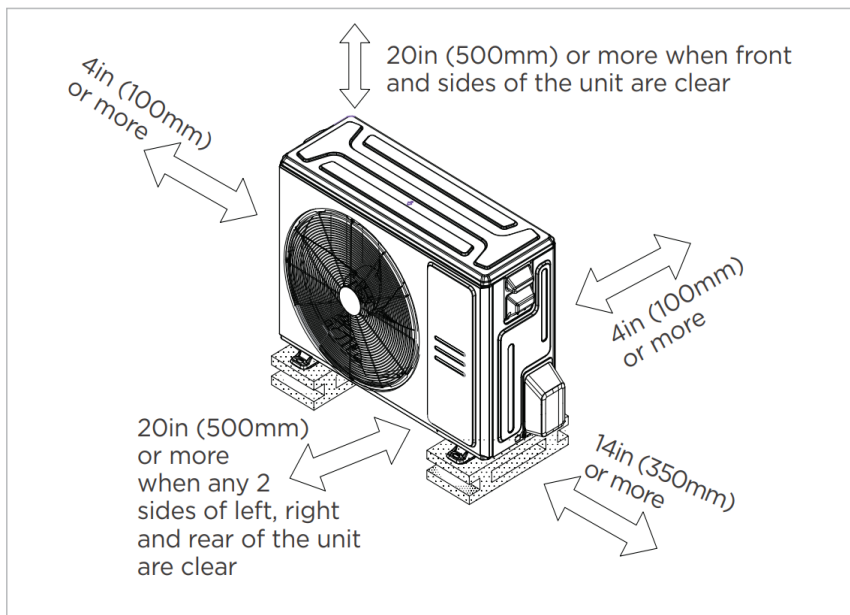

Meets all spatial requirements shown in Installation Clearance Requirements above.

FEATURES

- Indoor unit TU1 copper coil
- Humidity control
- 1~100% fan speed setting
- WiFi capability: through WiFi dongle or wired controller with built-in WiFi
- OTA(by using WiFi dongle)
- Multiple control options available:
 - Two way communication wired controller:120N(X6)
 - Two way communication wired controller with built-in WiFi:120N(X6W)
 - Infrared wired controller: 120L
 - Wireless remote controller
 - Third-Party 24V Thermostat*

*24V interface is required.