

SUBMITTAL DATA SHEET

High Wall Heat Pump System BDAFA36WM0-BDS2A36SC0

Location:	Approval:
Engineer:	Date:
Submitted to:	Construction:
Submitted by:	Unit #:
Reference:	Drawing #:



INDOOR SPECIFICATION

Indoor Air Flow (Turbo/H/M/L/Si) (CFM)	847.6 / 588.6 / 518.0 / 400.2 / /	
Indoor Noise Level (Turbo/H/M/L/Si) (dBA)	55.5/49.5/43.5/38.0/27.5	
Dimension (W×D×H)	inch	49.57 x 11.10 x 14.25
	mm	1259×282×362
Package (W×D×H)	inch	53.94 x 18.74 x 16.57
	mm	1370×476×421
Net/Gross Weight	lbs	48.72/67.90
	kg	22.1/30.8

OUTDOOR SPECIFICATION

Compressor Type	ROTARY	
Compressor Model	KTF250D22UMT	
Refrigerant	R454B	
Refrigerant Oil Charge(mL)	670	
Refrigerant Oil	10.0	
Outdoor Air Flow (Max) (CFM)	3800	
Outdoor Noise Level (dBA)	60.5	
Dimension (W×D×H)	inch	37.24 x 16.14 x 31.89
	mm	946×410×810
Package (W×D×H)	inch	42.91 x 19.88 x 37.01
	mm	1090×505×940
Net/Gross Weight	lbs	152.12/183.42
	kg	69/83.2

EFFICIENCY

Cooling		Heating	
SEER2	18.0	HSPF2-4	8.5
EER2	8.5	COP	2.75

PERFORMANCE of Cooling

Cooling (Btu/hr)	
Rated Capacity	36000
Min/Max Capacity	6300~36000
Moisture Removal(L/h)	5.44
Standard Operating Range(°F/°C)	-13~122(-25~50)
Conditions:	Indoor: 80°F DB/67°F WB Outdoor: 95°F DB/75°F WB

PERFORMANCE of Heating

Heating (Btu/hr)	
1. @ 47°F Rated	36000
1. @ 47°F Min/Max Capacity	12100~36800
2. @ 17°F Rated	23400
3. @ 5°F Rated: Capacity / COP	22000/1.97
3. @ 5°F Max: Capacity	22000
Standard Operating Range(°F/°C)	-13~75(-25~24)
1. Conditions:	Indoor: 70°F DB/60°F WB Outdoor: 47°F DB/43°F WB
2. Conditions:	Indoor: 70°F DB/60°F WB Outdoor: 17°F DB/15°F WB
3. Conditions:	Indoor: 70°F DB/60°F WB Outdoor: 5°F DB/5°F WB

ELECTRICAL

Power Supply	208/230V,60Hz,1Ph	
System MCA	33	
Connection Wiring	14#x4	
System MOCP	35	
Compressor RLA	21.5	
Outdoor Fan Motor RLA	1.3	
Outdoor Fan Motor W	120	
Indoor Fan Motor RLA	0.7	
Indoor Fan Motor W	58	
System Power Input @ Cooling (W)	4235(770 ~ 4200)	
System Power Input @ Heating (W)	3837(735 ~4090)	
MCA: Min. circuit amps (A)	MOCP: Max. over current protection (A)	
RLA: Rated load amps (A)	W: Fan motor rated output (W)	

PIPING

Throttle type(Indoor)	N/A	
Throttle type(Outdoor)	EXV+Throttle valve	
Liquid Size	9.52mm(3/8in)	
Gas Size	15.9mm(5/8in)	
Max. Piping Length(ft/m)	213.20(65)	
Max. Height Difference(ft/m)	98.40(30)	
Max. Pre-charged Length(ft/m)	24.6(7.5)	
Refrigerant Pre-charged Amount(oz/g)	109.70(3.11)	
Additional Charge of Refrigerant(oz/ft)/(g/m)	0.32(30)	
Connection Method	Flared	

Indoor Unit Dimension

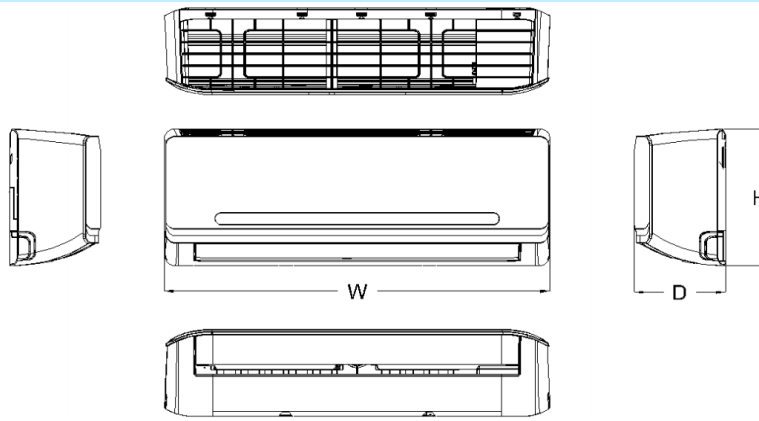

Capacity	Body Code	W(inch/mm)	D(inch/mm)	H(inch/mm)
9k Entry Tier Series	A	28-1/2in /722mm	7-3/8in /187mm	11-3/8in /290mm
9k~12k	B	31-1/2in /802mm	7-1/2in /189mm	11-3/4in /297mm
18k Entry Tier Series	D	38in /965mm	8-1/2in /215mm	12-1/2in /319mm
18k~24k	E	42-1/2in /1080mm	8-7/8in /226mm	13-1/4in /335mm
30k~36k	F	49-1/2in /1259mm	11-1/8in /282mm	14-1/4in /362mm

Installation Instruction

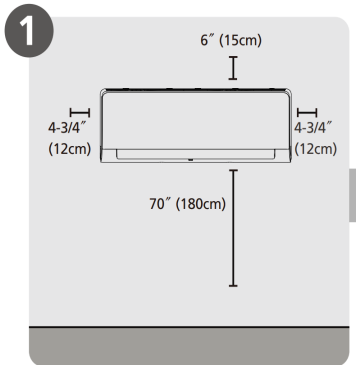

Select Installation Location

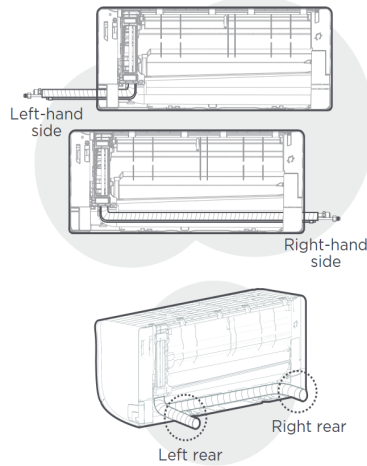

NOTE:
Based on the position of the wall hole relative to the mounting plate, choose the side from which the piping will exit the unit. You have four options for the exit direction of the piping.

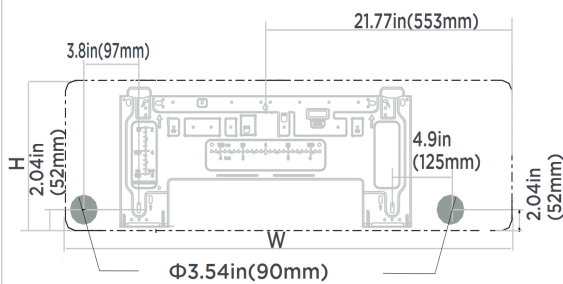

NOTE:
When the gas side connective pipe is Φ (5/8in)16mm or more, the wall hole should be (3-1/2in)90mm.

Indoor unit dimensions(WxH):
42.52in(1080mm)x13.19(335mm)

Outdoor Unit Dimension

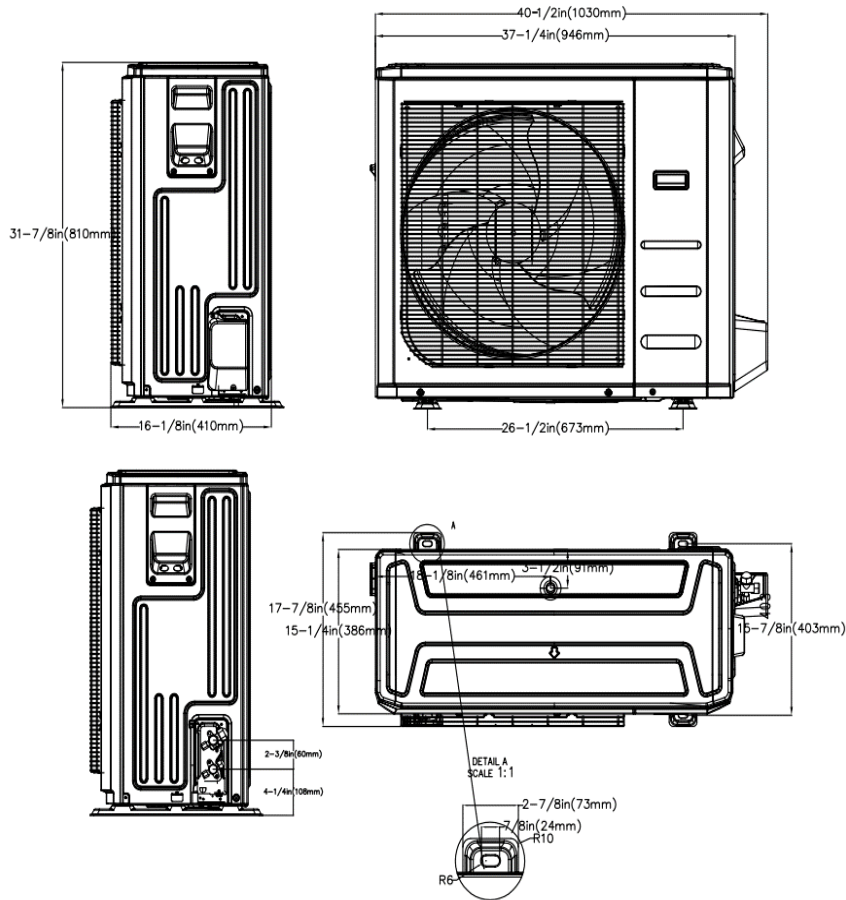

Installation Instruction

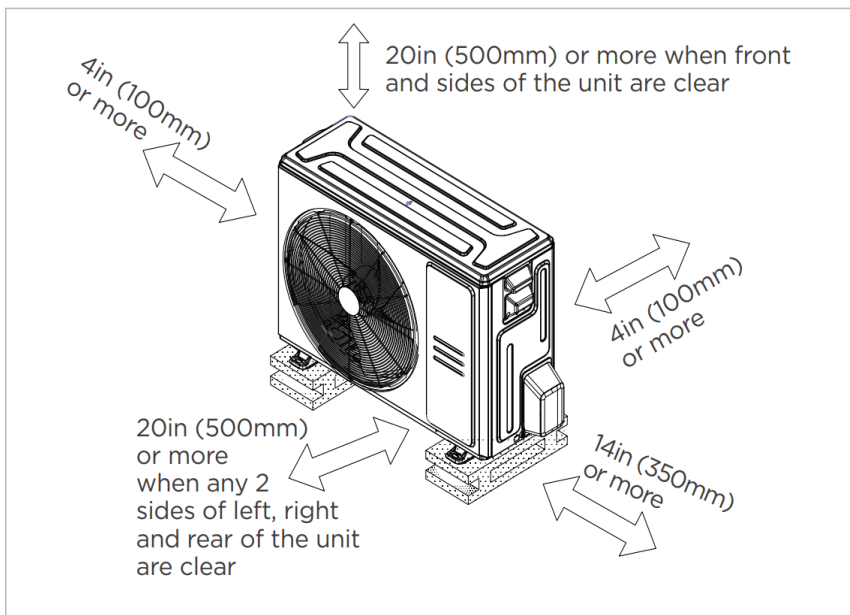

Meets all spatial requirements shown in Installation Clearance Requirements above.

FEATURES

- Indoor unit TU1 copper coil
- Humidity control
- 1~100% fan speed setting
- WiFi capability: through WiFi dongle or wired controller with built-in WiFi
- OTA(by using WiFi dongle)
- Multiple control options available:
 - Two way communication wired controller:120N(X6)
 - Two way communication wired controller with built-in WiFi:120N(X6W)
 - Infrared wired controller: 120L
 - Wireless remote controller
 - Third-Party 24V Thermostat*

*24V interface is required.