

BHP17L

PRODUCT SPECIFICATIONS

HIGH EFFICIENCY
SPLIT SYSTEM HEAT PUMP
UP TO 18.2 SEER & 10.6 HSPF
UP TO 16.8 SEER2 & 8.5 HSPF2

FORM NO. 4HP17L-100 (09/2022)



COMPRESSOR

- High-efficiency scroll compressor
- R410A refrigerant
- Grommet mounted compressor for quiet operation
- Internally protected against high temperature motor overload conditions
- Heavy-duty compressor sound blanket for quiet operation (optional accessory)

CABINET

- Full metal louvered panel removable for ease of coil cleaning and service
- Corner-mounted controls for easy service
- Baked polyester paint finished over galvanized steel for maximum durability
- External gauge ports for easy service
- Removable service panel for internal access

DESIGN

- Designed to perform in temperatures up to 125°F
- Designed to perform in temperatures down to 0°F

COILS

- Omniguard® total corrosion protection technology designed coil
- Enhanced tube-and-fin coil design
- Lanced fins for maximum heat transfer
- Factory tested for leakproof construction
- Raised coil prevents debris from impeding airflow

COMPONENTS

- Factory installed high and low pressure switches
- Thread-on pressure switches for simple, quick service
- Factory installed filter dryer
- Fan orifice for smoother airflow and sound level reduction
- Charged for 15 feet of line set
- Discharge muffler for quiet operation
- Quiet Shift™ capable to reduce noise during defrost

WARRANTY

- 5 year limited warranty on all parts and compressor
- Available 10 year warranty on all parts and compressor with registration*

**Warranty provides for a total of 10 years of limited warranty coverage (Standard 5-year limited parts warranty plus an additional 5-year limited extended parts warranty). Warranty must be registered online within 60 days of installation to qualify for 10-year coverage. Unregistered equipment defaults to 5-year coverage. See full warranty at www.blueridgewarranty.com for terms, conditions and exclusions.*

NOTE:

For the latest AHRI system matches, please visit www.AHRIdirectory.org



MODEL NUMBER GUIDE

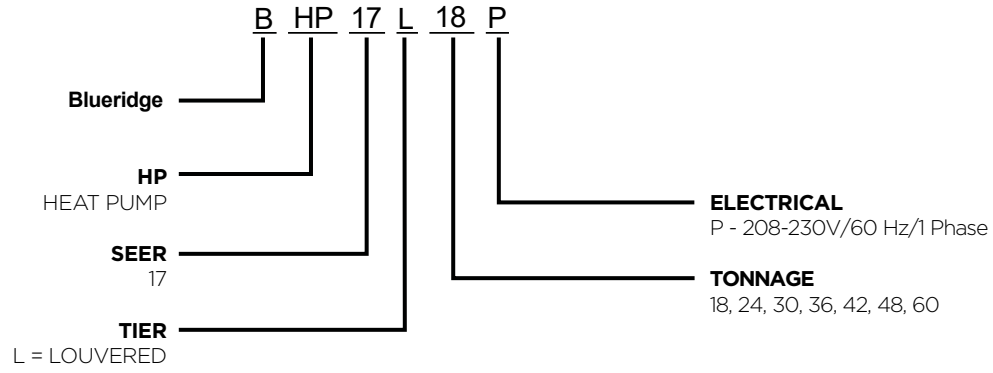

PHYSICAL AND ELECTRICAL DATA

Model	Voltage/Hz/ Phase	Voltage Range	Min. Circuit Amp.	Max. Over Current Device (amps)	Compressor		Outdoor Fan Motor		
					Rated Load (amps)	Locked Rotor (amps)	Full Load (amps)	Rated HP	Nom. RPM
BHP17L18P	208-230/60/1	197-253	13.6	20	10.3	45.7	0.7	1/8	825
BHP17L24P	208-230/60/1	197-253	15.1	25	11.5	59.5	0.7	1/8	825
BHP17L30P	208-230/60/1	197-253	15.6	25	11.7	71.3	1.0	1/6	825
BHP17L36P	208-230/60/1	197-253	17.8	30	13.1	83.1	1.4	1/5	825
BHP17L42P	208-230/60/1	197-253	25.9	40	18.6	110.0	2.6	1/3	825
BHP17L48P	208-230/60/1	197-253	33.9	50	25.0	120.0	2.6	1/3	825
BHP17L60P	208-230/60/1	197-253	32.5	50	23.9	124.5	2.6	1/3	825

UNIT DIMENSIONS (IN.)

Model	Dimensions (inch)			Shipping Weight (lbs.)
	A - Width	B - Depth	C - Height	
BHP17L18P	28.25	28.25	43	185
BHP17L24P	28.25	28.25	43	185
BHP17L30P	28.25	28.25	33	185
BHP17L36P	32.25	32.25	33	220
BHP17L42P	32.25	32.25	38	250
BHP17L48P	32.25	32.25	38	250
BHP17L60P	32.25	32.25	43	260

Note:
Dimensions listed are unit sizes w/o packaging
Weights listed are unit weights with packaging

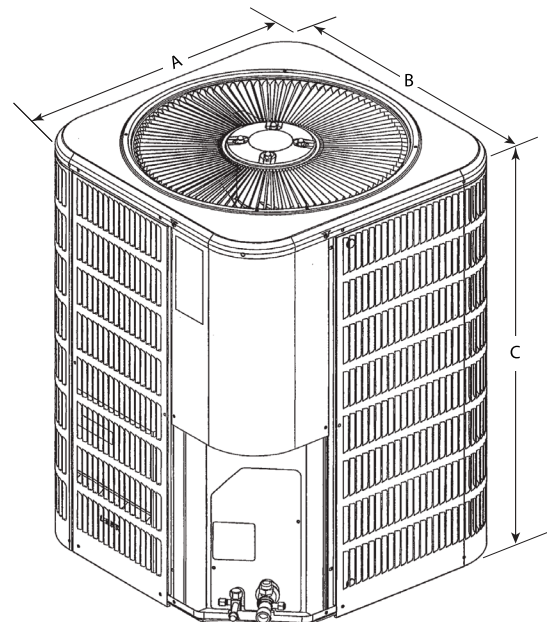

UNIT SOUND RATINGS

Model	Sound Power ¹	Estimated Sound Pressure (dBA) ²		
		Approximate Distance ³		
		3.3 Feet (1 Meter)	6.6 Feet (2 Meters)	9.8 Feet (3 Meters)
BHP17L18P	74	66	60	56
BHP17L24P	74	66	60	56
BHP17L30P	74	66	60	56
BHP17L36P	75	67	61	57
BHP17L42P	78	70	64	60
BHP17L48P	79	71	65	61
BHP17L60P	79	71	65	61

¹ Rated in accordance with AHRI standard 270 (2015)

² Rated in accordance with AHRI standard 275 (2010)

³ Based only on distance factor; other factors may change this value such as:

- Unit location (reflective surfaces adjacent to the unit)
- Barrier shielding sources
- Sound path/elevation
- Outside noise sources

REFRIGERATION DATA

Model	Refrig. Charge (Oz.)*	TXV	Refrigerant Line Size		Outdoor Unit Connection		Indoor Unit Connection	
			Suction	Liquid	Suction	Liquid	Suction	Liquid
BHP17L18P	98	H4TXV01	3/4	3/8	3/4	3/8	3/4	3/8
BHP17L24P	96	H4TXV01	3/4	3/8	3/4	3/8	3/4	3/8
BHP17L30P	117	H4TXV01	3/4	3/8	3/4	3/8	3/4	3/8
BHP17L36P	137	H4TXV02	7/8	3/8	7/8	3/8	7/8	3/8
BHP17L42P	162	H4TXV02	7/8	3/8	7/8	3/8	7/8	3/8
BHP17L48P	146	H4TXV02	7/8	3/8	7/8	3/8	7/8	3/8
BHP17L60P	164	H4TXV03	1-1/8	3/8	1-1/8	3/8	1-1/8	3/8

* Factory charged for 15 feet of line set; adjust per installation instructions.

** Reducer fitting supplied with OD unit

COOLING PERFORMANCE WITH AIR HANDLERS AND FURNACES

Outdoor Model	Indoor Model Evap. Coil or Air Handler ³	Cooling						Heating					
		SEER	SEER2	EER	EER2	AHRI Rated Capacity ¹	Sensible Capacity	HSPF	HSPF2	47°		17°	
										Btuh	COP	Btuh	COP
BHP17L18P	BCE5C18MA4X	15.5	15.2	13.0	13.0	18,000	14,400	9.2	8.0	17,900	3.80	11,200	2.54
BHP17L24P	BCE5C24MA4X	15.5	14.7	13.0	12.4	23,200	17,800	9.6	8.0	22,200	3.72	14,000	2.54
BHP17L30P	BCE5C30MA4X	15.0	14.4	12.2	12.0	28,400	22,400	9.2	8.0	27,800	3.56	18,000	2.52
BHP17L36P	BCE5C36MA4X	15.5	14.7	12.5	12.4	35,600	27,000	9.6	8.0	34,000	3.62	22,400	2.56
BHP17L42P	BCE5C42MA4X	15.0	14.4	12.2	12.0	40,500	30,800	9.2	7.8	39,000	3.40	25,000	2.46
BHP17L48P	BCE5C48MA4X	15.4	14.7	12.5	12.4	47,000	35,400	9.8	8.2	46,500	3.64	30,400	2.64
BHP17L60P	BCE5C60MA4X	15.1	14.3	12.5	11.7	56,500	41,500	9.6	8.0	54,000	3.50	35,000	2.56

Note:

¹ Certified in accordance with Unitary Air Conditioner Certification Program, which is based on AHRI Standard 210/240

² Required to achieve AHRI rating. If NA (not applicable) is in the piston column then TXV is required.

³ Blower time delay relay is standard on all **Blueridge** furnace and AH products.

NOTE:

For the latest AHRI system matches, please visit
www.alliedratings.com or www.AHRIdirectory.org

ACCESSORIES

System Accessory	Where Used	Kit Number	Purpose
Liquid Line Solenoid	All models	60M52	Prevents liquid migration to the compressor especially for high liquid riser applications
Low Ambient (cooling operation)	All models	54M89	Enables cooling demand down to 30 °F. Will require freeze stat, CC heater and TXV
Mild Ambient (heating operation)	All models	11B97	Enables heating demand above 60 °F ambient
Cold Weather	All models	1.921145	To allow unit to operate at very low ambient conditions (older models). Board integrated feature on new models
Fossil Fuel Kit (Heat Pump Only)	All models	1.841185 (AFOSL500)	Required for furnace with heat pump installations
Hard Start	24 & 36	10J42	Scroll compressors usually do not require hard start; maybe needed for utility brown-out or low voltage areas
	48 & 60	81J69	
Crankcase Heater	18, 24, 30	93M04	Prevents liquid migration to compressor in cold weather
	36, 42, 48, 60	Factory Installed	
Sound Cover	18, 24, 30, 36	14W00	Lowers compressor sound level
	42, 48, 60	14W01	
Loss of Charge Kit	Factory Installed		Protects the compressor if refrigerant charge is too low
Additional System Accessories (indoor section)			
TXV Kit	18, 24, 30	H4TXV01	TXVs provide superior refrigerant flow control, comfort and efficiency compared to pistons
	36, 42, 48	H4TXV02	
	60	H4TXV03	
Outdoor Thermostat - Electric Heat	All models	10Z23 (56A87)	Prevents electric heat operation above specific ambient conditions
Outdoor Thermostat - Mounting Box	All models	31461	Mounting box for outdoor thermostat
Freezestat	All models	93G35	Protects the compressor at low suction pressure conditions
Overflow switch	All models	11U75	Turn the system off, if condensate water overflows due to clogged drain pipes
Single Point Power Supply	All models	21H39	Provide single power source in one junction box
Auxiliary Blower Relay	All models	85W66	Maybe required to select multiple indoor blower speeds