

AIR-HANDLER

AIR CONDITIONER

EN

Installation Manual

Safety precautions & Installation



BMAHM1820I
BMAHM2420I
BMAHM3618I

IMPORTANT NOTE:

Read this manual carefully before installing or operating your new air conditioning unit. Make sure to save this manual for future reference.



North America Products

INSTALLATION MANUAL

SAFETY PRECAUTIONS	02
ACCESSORIES	06
INDOOR UNIT INSTALLATION	07
REFRIGERANT PIPING CONNECTION	17
INSTALLATION OF ELECTRIC AUXILIARY HEAT MODULE (ONLY FOR HEAT FUNCTION MODELS)	21
CONFIRMATION OF INDOOR UNIT	23
OUTDOOR UNIT INSTALLATION	27
WIRING PRECAUTIONS	31
SPECIFICATION	42
AIR EVACUATION	43
NOTE ON ADDING REFRIGERANT	44
TEST RUN	45

Read this manual

Inside you'll find many helpful hints on how to use and maintain your air conditioner properly. Just a little preventive care on your part can save you a great deal of time and money over the life of your air conditioner. These instructions may not cover every possible condition of use, so common sense and attention to safety is required when installing, operating and maintaining this product.

SAFETY PRECAUTIONS

Intended Use

The following safety guidelines are intended to prevent unforeseen risks or damage from unsafe or incorrect operation of the appliance. Please check the packaging and appliance on arrival to make sure everything is intact to ensure safe operation. If you find any damage, please contact the retailer or dealer. Please note modifications or alterations to the appliance are not allowed for your safety. Unintended use may cause hazards and loss of warranty claims.

Explanation of Symbols



WARNING

The signal word indicates a hazard with a medium level of risk which, if not avoided, may result in death or serious injury.



CAUTION

The signal word indicates a hazard with a low degree of risk which, if not avoided, may result in minor or moderate injury.



NOTICE

The signal word indicates important information (e.g. damage to property), but not danger.

Read these operating instructions carefully and attentively before using/commissioning the unit and keep them in the immediate vicinity of the installation site or unit for later use!

WARNING

This appliance is not intended for use by persons (including children) with reduced physical, sensory or mental capabilities, or lack of experience and knowledge, unless they have been given supervision or instruction concerning use of the appliance by a person responsible for their safety. Children should be supervised to ensure that they do not play with the appliance.

WARNINGS FOR PRODUCT USE

- If an abnormal situation arises (like a burning smell), immediately turn off the unit and disconnect the power. Call your dealer for instructions to avoid electric shock, fire or injury.
- **Do not** insert fingers, rods or other objects into the air inlet or outlet. This may cause injury, since the fan may be rotating at high speeds.
- **Do not** use flammable sprays such as hair spray, lacquer or paint near the unit. This may cause fire or combustion.
- **Do not** store gasoline or flammable substances near air conditioner. Emitted gas may collect around the unit and cause explosion.
- **Do not** install your air conditioner in a wet room such as a bathroom or laundry room. Too much exposure to water can cause electrical components to short circuit.
- **Do not** expose your body directly to cool air for a prolonged period of time.
- **Do not** allow children to play with the air conditioner. Children must be supervised around the unit at all times.
- If the air conditioner is used together with burners or other heating devices, thoroughly ventilate the room to avoid oxygen deficiency and carbon monoxide build up.
- In certain environments, such as kitchens, server rooms, etc., the use of specially designed air-conditioning units is highly recommended.
- Improper installation, adjustment, alteration, service or maintenance can cause property damage, personal injury or loss of life. Installation and service must be performed by a licensed professional HVAC installer or equivalent, service agency, or the gas supplier.

CAUTION

- Turn off the air conditioner and disconnect the power if you are not going to use it for a long time.
- Make sure that water condensation can drain unhindered from the unit.
- **Do not** operate the air conditioner with wet hands. This may cause electric shock.
- **Do not** use device for any other purpose than its intended use.
- **Do not** climb onto or place objects on top of the outdoor unit.
- **Do not** allow the air conditioner to operate for long periods of time with doors or windows open, or if the humidity is very high.
- As with any mechanical equipment, contact with sharp sheet metal edges can result in personal injury. Take care while handling this equipment and wear gloves and protective clothing.

ELECTRICAL WARNINGS

- The product must be properly grounded at the time of installation, or electrical shock may occur.
- For all electrical work, follow all local and national wiring standards, regulations, and the Installation Manual. Connect cables tightly, and clamp them securely to prevent external forces from damaging the terminal. Improper electrical connections can overheat and cause fire, and may also cause shock. All electrical connections must be made according to the Electrical Connection Diagram located on the panels of the indoor and outdoor units.
- All wiring must be properly arranged to ensure that the control board cover can close properly. If the control board cover is not closed properly, it can lead to corrosion and cause the connection points on the terminal to heat up, catch fire, or cause electrical shock.

- If connecting power to fixed wiring, an all-pole disconnection device which has at least 3mm clearances in all poles, and have a leakage current that may exceed 10mA, the residual current device(RCD) having a rated residual operating current not exceeding 30mA, and disconnection must be incorporated in the fixed wiring in accordance with the wiring rules.

WARNINGS FOR PRODUCT INSTALLATION

- Installation must be performed by an authorized dealer or specialist. Defective installation can cause water leakage, electrical shock, or fire.
- Installation must be performed according to the installation instructions. Improper installation can cause water leakage, electrical shock, or fire.
(In North America, installation must be performed in accordance with the requirement of NEC and CEC by authorized personnel only.)
- Contact an authorized service provider for repair or maintenance of this unit. This appliance shall be installed in accordance with national wiring regulations.
- Only use the included accessories, parts, and specified parts for installation. Using non-standard parts can cause water leakage, electrical shock, fire, and can cause the unit to fail.
- Install the unit in a firm location that can support the unit's weight. If the chosen location cannot support the unit's weight, or the installation is not done properly, the unit may fall and cause serious injury and damage.
- Install drainage piping according to the instructions in this manual. Improper drainage may cause water damage to your home and property.
- For units that have an auxiliary electric heater, do not install the unit within 1 meter (3 feet) of any combustible materials.
- **Do not** install the unit in a location that may be exposed to combustible gas leaks. If combustible gas accumulates around the unit, it may cause fire.
- Do not turn on the power until all work has been completed.
- When moving or relocating the air conditioner, consult experienced service technicians for disconnection and reinstallation of the unit.
How to install the appliance to its support, please read the information for details in "indoor unit installation" and "outdoor unit installation" sections .
- Excessive Weight Hazard - Use two or more people when moving and installing the unit. Failure to do so can result in back or other type of injury.

WARNINGS FOR CLEANING AND MAINTENANCE

- Turn off the device and disconnect the power before cleaning. Failure to do so can cause electrical shock.
- **Do not** clean the air conditioner with excessive amounts of water.
- **Do not** clean the air conditioner with combustible cleaning agents. Combustible cleaning agents can cause fire or deformation.

NOTE ABOUT FUSE SPECIFICATIONS

- The air conditioner's circuit board (PCB) may be designed with a fuse to provide overcurrent protection. This fuse must be replaced with an identical component.
- The specifications of the fuse, if equipped, are printed on the circuit board, examples of which are T5A/250VAC and T10A/250VAC.

NOTE ABOUT FLUORINATED GASES (NOT APPLICABLE TO THE UNIT USING R290 REFRIGERANT)

- This air-conditioning unit contains fluorinated greenhouse gases. For specific information on the type of gas and the amount, please refer to the relevant label on the unit itself or the "Owner's Manual - Product Fiche" in the packaging of the outdoor unit. (European Union products only).
- Installation, service, maintenance and repair of this unit must be performed by a certified technician.
- Product uninstallation and recycling must be performed by a certified technician.
- When the unit is checked for leaks, proper record-keeping of all checks is strongly recommended.

The allowed static pressure range of the air conditioner on site is 0-0.80 in-H₂O (0-200 Pa). The data below represents the static pressures at full required air flow used for AHRI testing.

MODEL	18-24K	30-36K	48-60K
PRESSURE (Before Jan,1,2023)	0.10 in-H ₂ O(25Pa)	0.15 in-H ₂ O(37Pa)	0.20 in-H ₂ O(50Pa)
PRESSURE (After Jan,1,2023)	0.5 in-H ₂ O(125Pa)	0.5 in-H ₂ O(125Pa)	0.5 in-H ₂ O(125Pa)







NOTE

The maximum functional total external static pressure can not exceed 0.80 in WC or 200 Pa. The airflow reduces significantly beyond 0.80 in WC or 200Pa. System design should allow for the increased resistance of filters as they become dirty.



ACCESSORIES

The air conditioning system comes with the following accessories. Use all of the installation parts and accessories to install the air conditioner. Improper installation may result in water leakage, electrical shock and fire, or equipment failure.

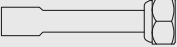
Accessories (Packed with the indoor unit)

Name	Picture	Quantity
Manual		3
Remote controller (optional)		1
Battery (optional)		2
Wired remote controller		1
Cable ties		2
Foam		4
Flare nut (optional)		2
Braze to flare adapter (optional)		2

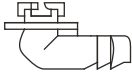
Accessories-optional (Packed with the outdoor unit)

Name	Picture	Quantity
Drain fitting		1
Gasket		1

NOTICE

The wired system control functions as an IR receiver for the handheld remote, if the remote is not used it must be retained with the indoor unit to adjust parameters, and for troubleshooting.

INDOOR UNIT INSTALLATION

⚠ CAUTION

Install the indoor and outdoor units, cables and wires at least 1m (3-1/5') from televisions or radios to prevent static or image distortion. Depending on the appliances, a 1m (3-1/5') distance may not be sufficient.

The Indoor unit must be electrically grounded per national and local electrical code.

Select the installation location of indoor units

⚠ WARNING DO NOT LOCATIONS:



DO NOT install the indoor unit in a moist environment. Excessive moisture can corrode the equipment, electrical components, and cause electrical shorts.



Areas with strong electromagnetic waves.



Coastal areas with high salt content in the air.



Areas with oil drilling or fracking.



Areas that store flammable materials or gas.



Areas where there may be detergent or other corrosive gases in the air, such as bathrooms, or laundry rooms.

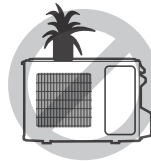

Areas where the air inlet and outlet may be obstructed.



Danger of explosion. Keep flammable materials and vapors, such as gasoline, away from air handler.

⚠ WARNING MUST BE INSTALLED IN A LOCATION THAT MEETS THE FOLLOWING REQUIREMENTS:

A stable position

- ☑ Securely install the indoor unit on a structure that can support its weight. If the structure is too weak, the unit may fall and cause personal injury, unit and property damage, or death.

At least 18in(46cm)

- ☑ Place air handler so that heating elements are at least 18 inches (46 cm) above the floor for a garage installation. Failure to follow these instructions can result in death, explosion, or fire.

spaciousness

- ☑ Enough room for installation and maintenance.
- ☑ Enough room for the connecting pipe and drainpipe.

Must support the weight of the indoor unit.

- ☑ The structure that the equipment is suspended from must support the weight of the indoor unit.

⚠ WARNING

There must be an airtight seal between the bottom of the air handler and the return air plenum. Use fiberglass sealing strips, foil duct tape, caulking, or equivalent sealing method between the plenum and the air handler cabinet to ensure a tight seal. Return air must not be drawn from a room where this air handler or any gas-fueled appliance (i.e., water heater), or carbon monoxide-producing device (i.e., wood fireplace) is installed.

Preparation and precautions for indoor unit installation

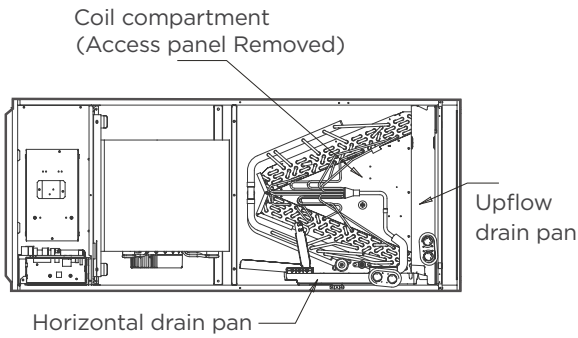

⚠ WARNING

- Please apply sealant around the places where the wires, refrigerant pipes and condensate pipes enter the cabinet.
- Use duct tape or flexible sealant to seal closed anyspace around the holes where the drain lines exit the cabinet. Warm air must not be allowed to enter through any gaps or holes in the cabinet.



💡 NOTICE

- Remove all accessories and packing in the air outlet before installation.

Recommended Distances Between the Indoor Unit

The distance between the mounted indoor unit should meet the specifications illustrated in the following diagram.

Horizontal installations

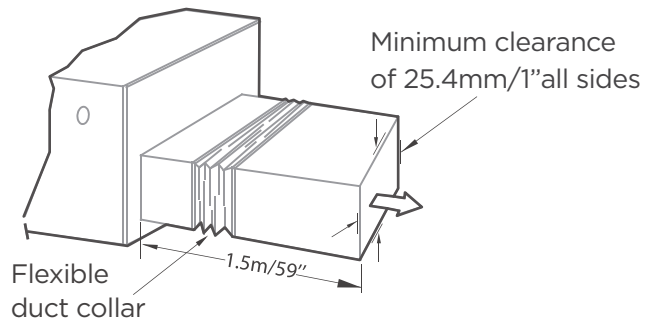

The outlet side pipe length 1.5m/59".

Vertical installations



Fixing instructions: When installed vertically (upward or downward), the lower end of the air outlet needs to be connected to the L-shaped metal air duct and fastened by screws.

Indoor unit parts installation size

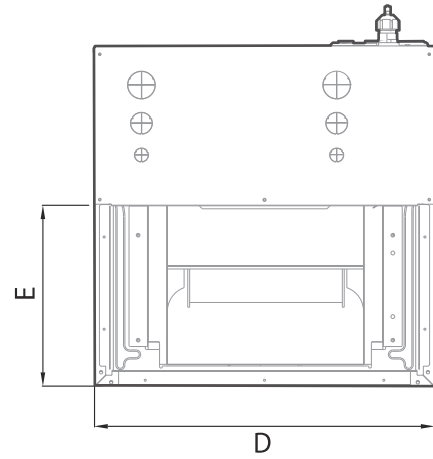
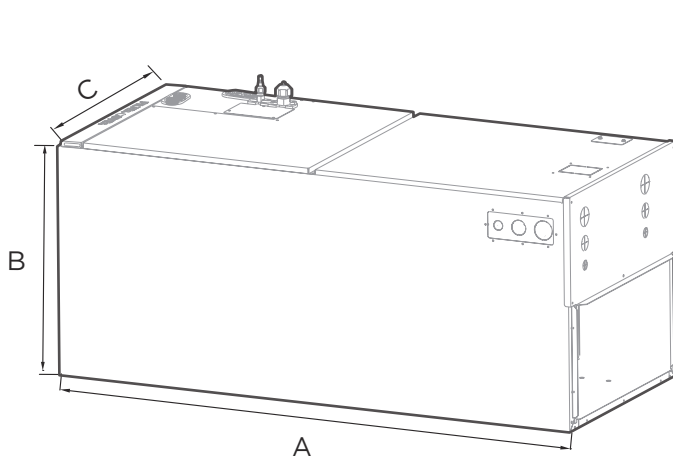

(unit: mm/inch)

Model A

Dimensions	Model(Btu/h)	Model(Btu/h)		
		12K-24K	30K-48K	60K
Length of A	mm	1143	1245	1346
	inch	45	49	53
Length of B	mm	533	533	533
	inch	21	21	21
Length of C	mm	445	534	622
	inch	17-1/2	21-1/50	24-1/2
Length of D	mm	400	490	580
	inch	15-3/4	19-5/16	22-27/32
Length of E	mm	260	260	260
	inch	10-1/4	10-1/4	10-1/4

Model B

Dimensions	Model(Btu/h)	Model(Btu/h)
		60K
Length of A	mm	1245
	inch	49
Length of B	mm	533
	inch	21
Length of C	mm	534
	inch	21-1/50
Length of D	mm	490
	inch	19-5/16
Length of E	mm	260
	inch	10-1/4

Recommended size of filter

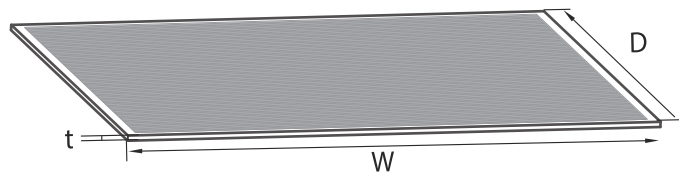

(unit: mm/inch)

NOTE:

The user needs to use a standard filter that meets the requirements of UL900.

Model(Btu/h)		18K-24K	30K-48K	60K
		Length of W	406.4	495.3
Length of D	mm	508	508	508
	inch	20	20	20
Length of t	mm	25.4	25.4	25.4
	inch	1	1	1

Installation Position Requirements

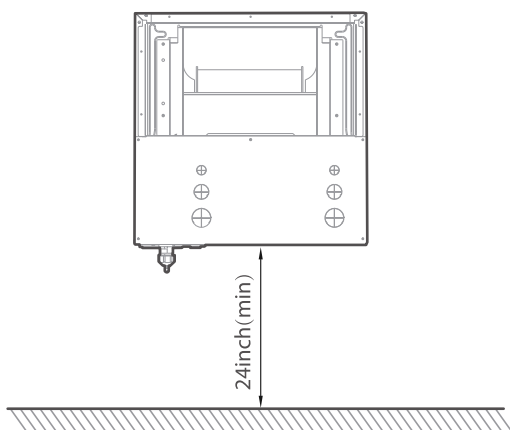

Vertical installations

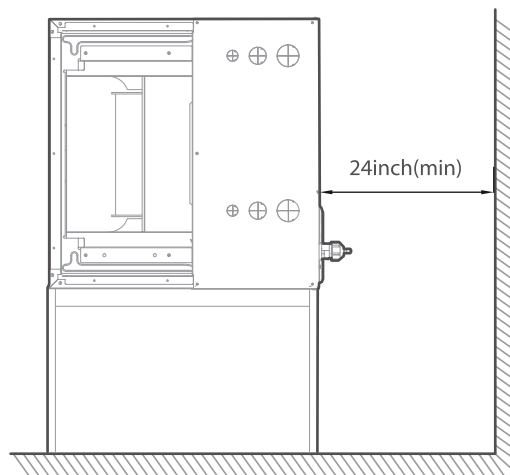

Horizontal installations

● NOTICE FOR DUCT CONNECTIONS:



It should be assembled accordance to the instructions.



It should be insulated and use a Vapor Barrier.



It should be Flexible suspension mounted and not fastened



It should be fabricated and installed in accordance with local and/or national codes.

More Requirements

- Air supply and return may be handled in one of several ways best suited to the installation (See table for dimensions for duct inlet and outlet connections). The vast majority of problems encountered with combination cooling systems can be linked to improperly designed or installed duct systems. It is therefore highly important to the success of an installation that the duct system be properly designed and installed. Use flexible duct collars to minimize the transmission of vibration/noise into the conditioned space. Where return air duct is short, or where sound could potentially to be a problem, sound absorbing liner should be used inside the duct.
- Duct must be insulated where it runs through an unconditioned space during the cooling season. The use of a vapor barrier is recommended to prevent absorption of moisture from the surrounding air into the insulation.
- The supply air duct connection should be properly sized by use of a transition to match unit opening.
- All ducts should be suspended using flexible hangers and never fastened directly to the structure. This unit is not designed for nonducted (freeblow) applications.
- Duct work should be fabricated and installed in accordance with local and/or national codes.

⚠ CAUTION

A field-fabricated secondary drain pan, with a drain pipe to the outside of the building, is required in all installations over a finished living space or in any area that may be damaged by overflow from the main drain pan. In some localities, local codes may require a secondary drain pan for any horizontal installation.

Selection of installation direction

Different installation directions

The units can be installed in a vertical (down and up) and Horizontal (right and left) configuration.

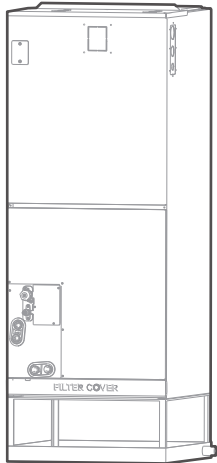

Vertical up

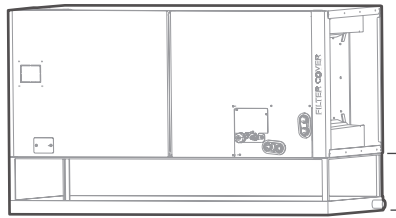

Horizontal

At least
5in(12.7cm)

💡 NOTICE

- For horizontal installation, a secondary drain pan (not supplied) must be installed.

Airflow direction of different installation directions

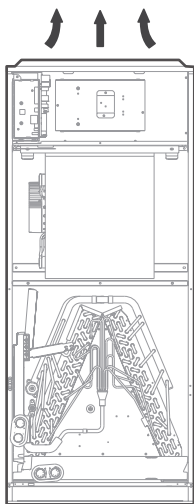

↑↑↑
Upflow

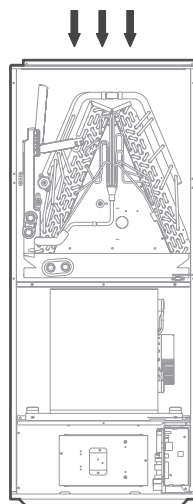

↓↓↓
Downflow

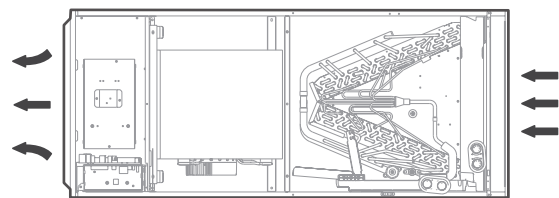

Horizontal left

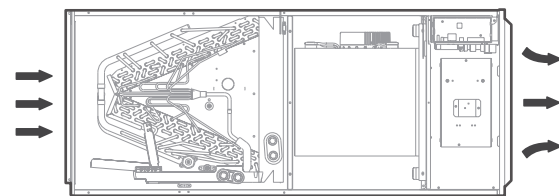

Horizontal right

💡 NOTICE

- Vertical up and horizontal left installation does not need to change the direction of evaporator.

Connecting the wire and pipes(pipes and drainage pipes)

Please follow these steps to perform **Vertical down** installation and **Horizontal right** installation:

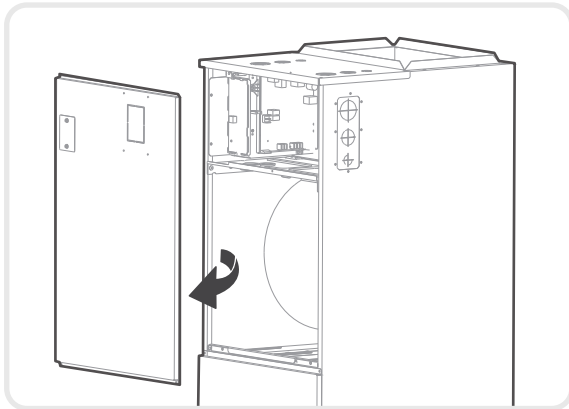

Step 1

Open the upper cover.

Step 2

Open the cover of the electronic control box.

Step 3

Connect the wire according to the wiring diagram.

Step 4

Connect the pipes and install the drainage pipes.

Down flow and horizontal right instructions

● NOTICE

The unit may be installed in one of the upflow, downflow, horizontal left or horizontal right orientations.

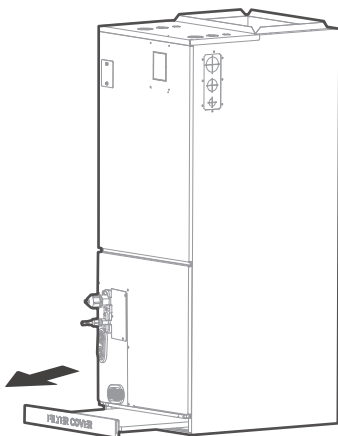

Step 1

Remove the filter door, then take the filter off.

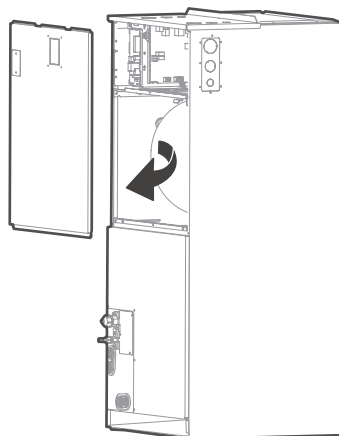

Step 2

Remove the upper cover assembly.

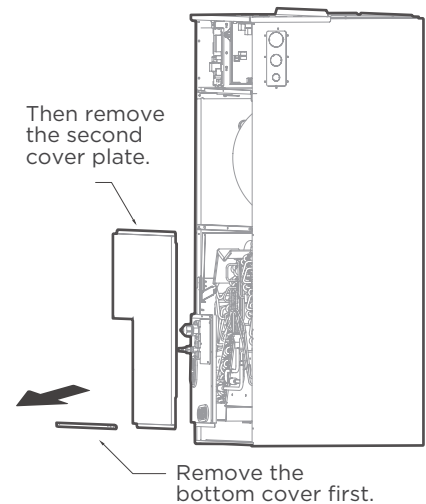

Step 3

Remove evaporator cover plate.

Step 4

Indication of the position of each temperature sensor of the evaporator, confirm your model.

18-24K model

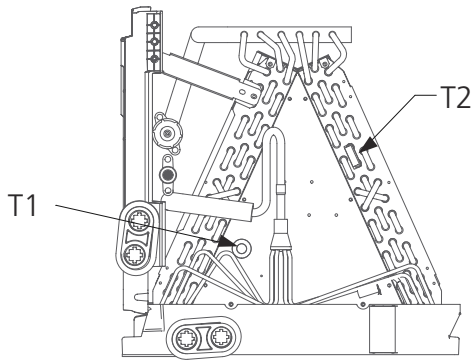

30-48K model

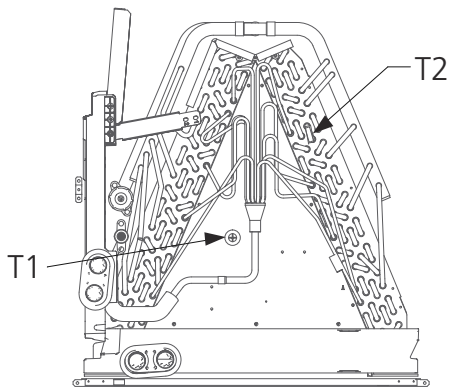

60K model

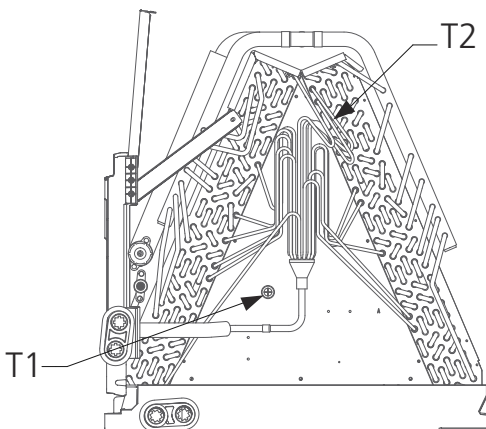

Step 5

Unplug temperature sensors T1,T2 from the control board.
T1: Room temperature sensor
T2: Evaporator central sensor plug

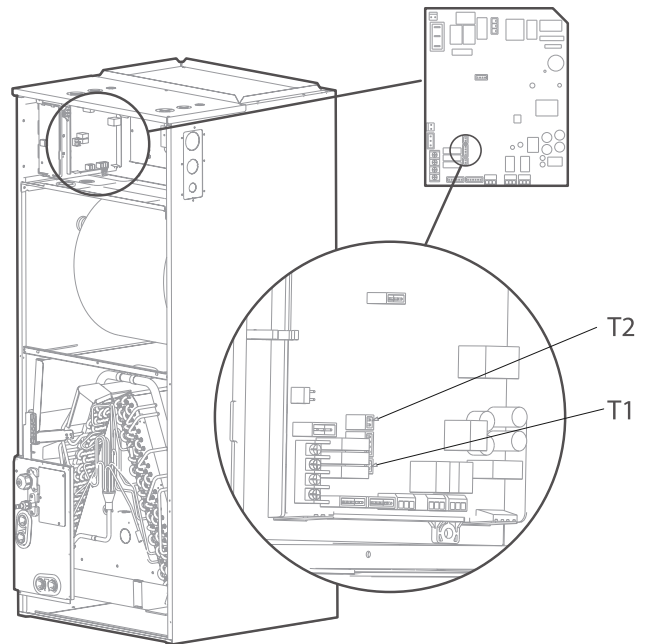

NOTICE

- T1 is only available for some models.

Step 6

Remove T1,T2 sensor wire ties.

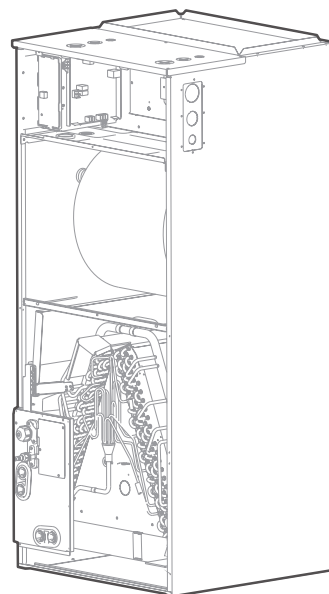

Step 6

Take out the evaporator and drain pan and rotate 180° (when your equipment need to be vertical downed configuration).

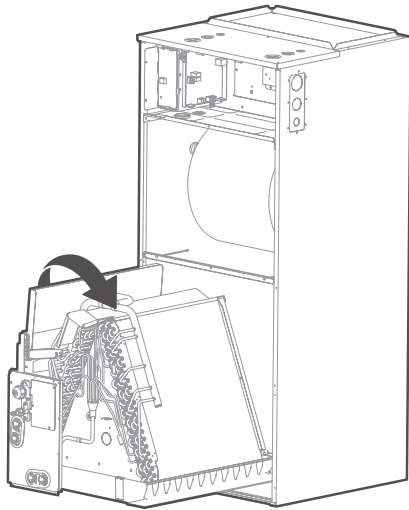

Step 7

Adjust the mounting parts position according to the direction of equipment.

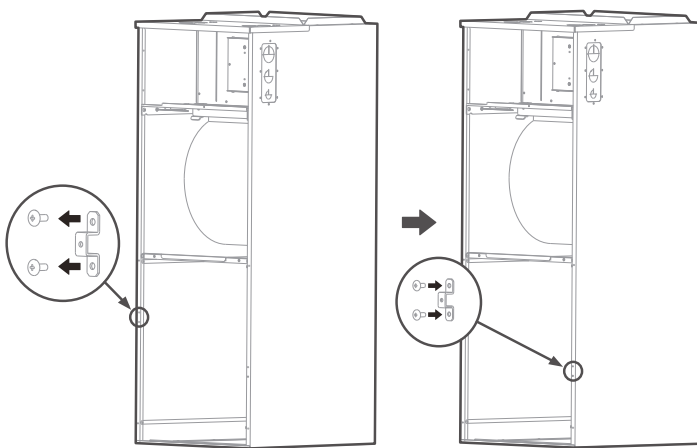

Step 8

Reinstall the evaporator and drain pan.

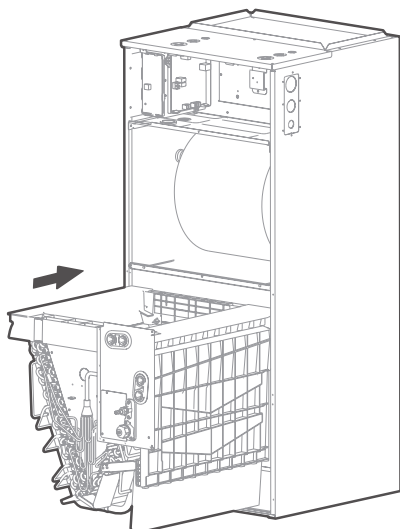

Step 9

Reinstall T1, T2 sensor plug and tie up the sensor wires.

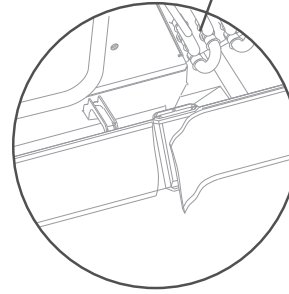
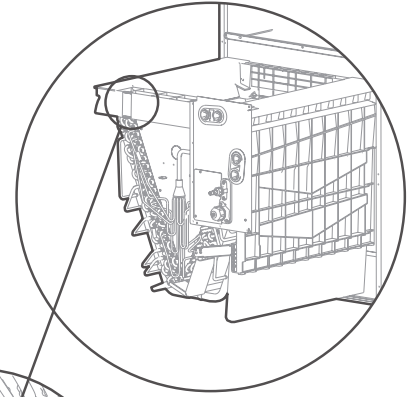

Cut the foam gasket.

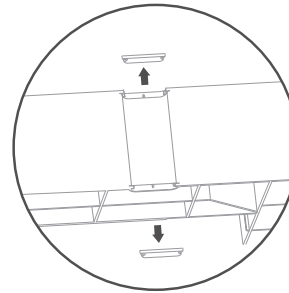

Remove knockouts as shown in the figure.

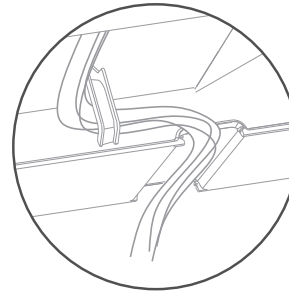

Hook the wire into the buckle and go down from the wire slot.

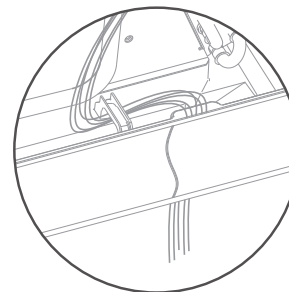

Replace foam gasket over wires.

NOTICE

The wire body needs to pass through the wire groove from the drain pan and be stuck on the hook of the drain pan.

Step 10

The evaporator is assembled in place.

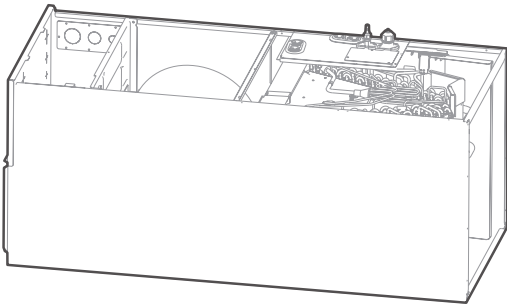

Step 11

Use cable ties to fix the room temperature sensor as shown in the figure.

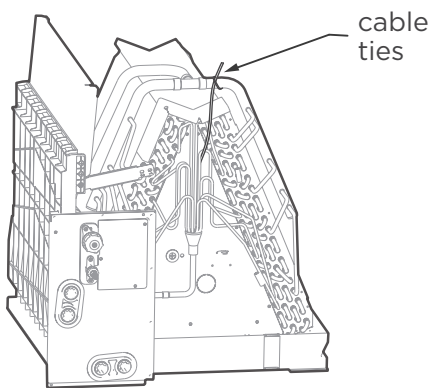

Step 12

Reinstall evaporator cover plate.

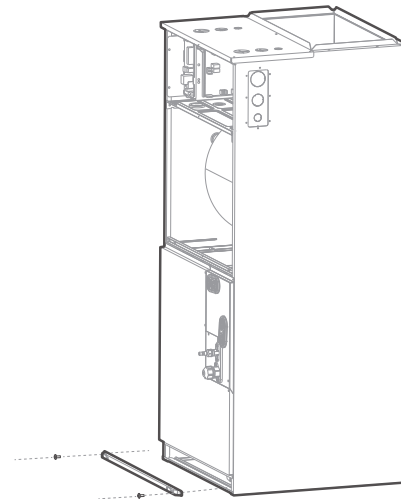

Step 13

Connect the wire according to the wiring diagram.

Step 14

Reassemble the upper cover and Reinstall the filter, filter cover plate.

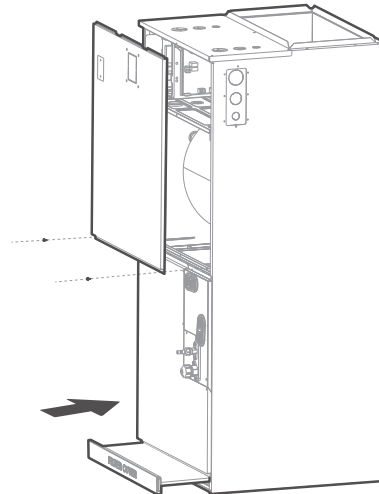

Step 15

Connect the pipes and install the drainage pipes.

⚠ CAUTION FOR ALL PIPES INSTALLATION

- Insulate all piping to prevent condensation, which could lead to water damage.
- The drainpipe is used to drain water away from the unit. If the drainpipe is bent or installed incorrectly, water may leak and cause a water-level switch malfunction.
- In HEAT mode, the outdoor unit will discharge water. Ensure that the drain hose is placed in an appropriate area to avoid water damage and icy conditions on walkways.
- **DO NOT** pull the drainpipe forcefully. This could disconnect it.

🔦 NOTICE

If installed above a finished living space, a secondary drain pan (as required by many building codes), must be installed under the entire unit and its condensate drain line must be routed to a location such that the user will see the condensate discharge.

● NOTICE ON PURCHASING PIPES

Installation requires pvc pipe or other suitable material per local and national codes, which can be obtained at your local hardware store or dealer.

⚠ WARNING

- After removal of drain pan plug(s), check drain hole(s) to verify that drain opening is fully open and free of any debris. Also check to make sure that no debris has fallen into the drain pan during installation that may plug up the drain opening. Seal around the exiting drain pipe, liquid and suction lines to prevent infiltration of humid air.
- On units of this type, where the blower “draws” rather than “blows” air through the coil, traps must be installed in the condensate drain lines (primary and auxiliary, if used). Traps prevent the blower from drawing air through the drain lines into the air supply.

Vertical Installations

These units operate with a negative pressure at the drain connections and a drain trap is required. The trap needs to be installed as close to the unit as possible. Make sure the top of the trap is below the connection to the drain pan to allow complete drainage of the pan.

Vertical discharge

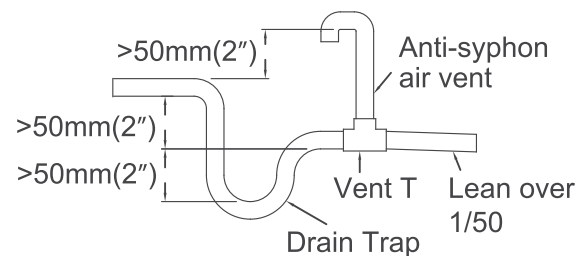
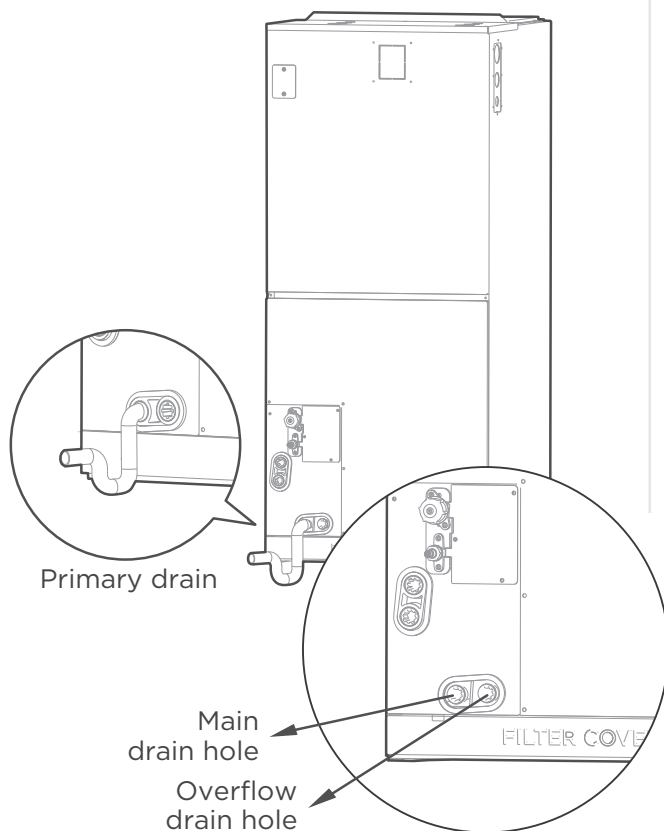

● NOTICE

Horizontal runs must also have an anti-siphon air vent(standpipe) install ahead of the horizontal run to eliminate air trapping.

NOTE ON DRAINPIPE INSTALLATION

- The Figure shows how to trap or plug all drains during vertical discharge.
- The Figure shows how to trap or plug all drains during right-hand discharge.
- The seal plug are supplied as accessories and should be screwed tightly only by hand.
- Incorrect installation could cause water to flow back into the unit and flood

⚠ CAUTION

The drainpipe outlet should be at least 5cm(1.9in) above the ground. If it touches the ground, the unit may become blocked and malfunction.

REFRIGERANT PIPING CONNECTION

⚠ WARNING

All field piping must be completed by a licensed technician and must comply with the local and national regulations.

- When the air conditioner is installed in a small room, measures must be taken to prevent the refrigerant concentration in the room from exceeding the safety limit in the event of refrigerant leakage. If the refrigerant leaks and its concentration exceeds its proper limit, hazards due to lack of oxygen may result.
- When installing the refrigeration system, ensure that air, dust, moisture or foreign substances do not enter the refrigerant circuit. Contamination in the system may cause poor operating capacity, high pressure in the refrigeration cycle, explosion or injury.
- Ventilate the area immediately if there is refrigerant leakage during the installation. Leaked refrigerant gas is both toxic and may be flammable. Ensure there is no refrigerant leakage after completing the installation work

Notes on pipe length and elevation

The maximum length and drop height based on models.(Unit:m/ft.)

Capacity (Btu/h)	MaxLength of piping		Maximum drop height	
	ft.	m	ft.	m
18k	98.4	30	65.6	20
24k/30k	164	50	82	25
36k/48k/60k	213	65	98.4	30

Ensure that the length of the refrigerant pipe, the number of bends, and the drop height between the indoor and outdoor units meets the requirements shown in the table next to it:

Name	Shape		Quantity(PC)
Connecting pipe assembly	Liquid side	Φ6.35(1/4in)	Parts you must purchase separately. Consult the dealer about the proper pipe size of the unit you purchased.
		Φ9.52(3/8in)	
	Gas side	Φ12.7(1/2in)	
		Φ16(5/8in)	
		Φ19(3/4in)	
		Φ22(7/8in)	

⚠ CAUTION

Oil traps

If oil flows back into the outdoor unit's compressor, this might cause liquid compression or deterioration of oil return. Oil traps in the rising gas piping can prevent this.

An oil trap should be installed every 6m(20ft) of vertical suction line riser (<36000Btu/h unit). An oil trap should be installed every 10m(32.8ft) of vertical suction line riser (≥36000Btu/h unit).

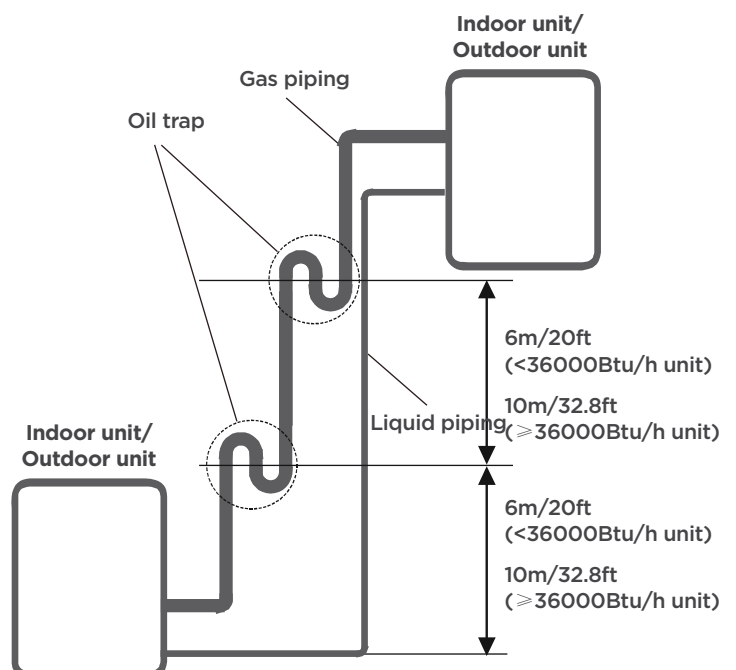

Connection Instructions—Refrigerant Piping

Step 1: Cut pipes

When preparing refrigerant pipes, take extra care to cut and flare them properly. This will ensure efficient operation and minimize the need for future maintenance.

- Measure the distance between the indoor and outdoor units.
- Using a pipe cutter, cut the pipe a little longer than the measured distance.
- Make sure that the pipe is cut at a perfect 90° angle.

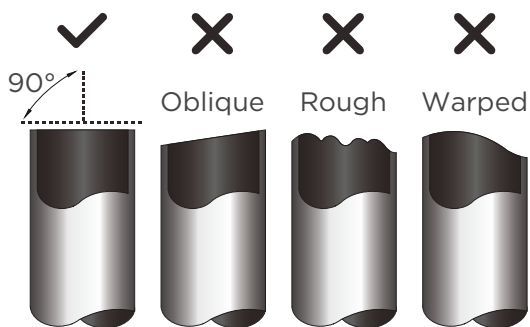

DO NOT DEFORM PIPE WHILE CUTTING

Be extra careful not to damage, kink, or deform the pipe while cutting. This will drastically reduce the heating performance

Step 2: Remove burrs

Burrs can affect the air-tight seal of refrigerant piping connection. They must be completely removed.

- Hold the pipe at a downward angle to prevent burrs from falling into the pipe.
- Using a reamer or deburring tool, remove all burrs from the cut section of the pipe.

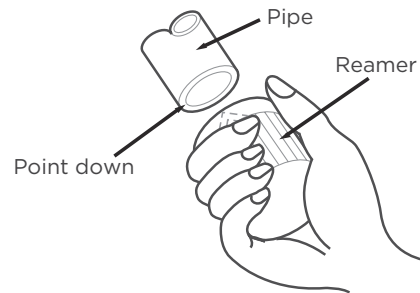

Step 3: Flare pipe ends

Proper flaring is essential to achieve an airtight seal.

- After removing burrs from cut pipe, seal the ends with PVC tape to prevent foreign materials from entering the pipe.
- Sheath the pipe with insulating material.
- Place flare nuts on both ends of pipe. Make sure they are facing in the right direction, because you can't put them on or change their direction after flaring.

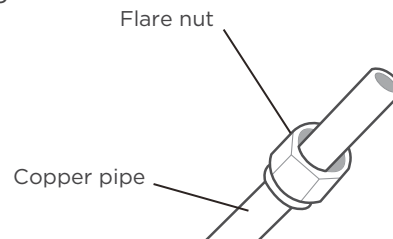

- Remove PVC tape from ends of pipe when ready to perform flaring work.

- Clamp flare form on the end of the pipe. The end of the pipe must extend beyond the flare form.

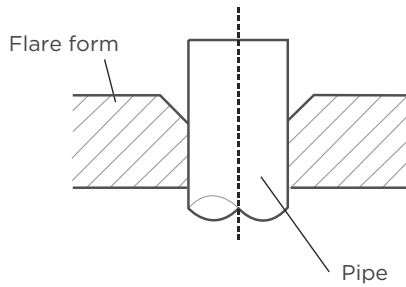

- Place flaring tool onto the form.
- Turn the handle of the flaring tool clockwise until the pipe is fully flared.

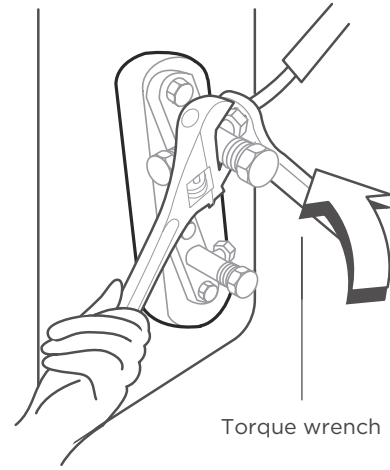

PIPING EXTENSION BEYOND FLARE FORM

Pipe gauge	Tightening torque	Flare dimension(A) (Unit:mm/Inch)		Flare shape
		Min.	Max.	
Ø 6.35 (Ø 1/4")	18-20 N.m (180-200kgf.cm)	8.4/0.33	8.7/0.34	
Ø 9.52 (Ø 3/8")	32-39 N.m (320-390kgf.cm)	13.2/0.52	13.5/0.53	
Ø 12.7 (Ø 1/2")	49-59 N.m (490-590kgf.cm)	16.2/0.64	16.5/0.65	
Ø 16 (Ø 5/8")	57-71 N.m (570-710kgf.cm)	19.2/0.76	19.7/0.78	
Ø 19 (Ø 3/4")	67-101 N.m (670-1010kgf.cm)	23.2/0.91	23.7/0.93	
Ø 22 (Ø 7/8")	85-110 N.m (850-1100kgf.cm)	26.4/1.04	26.9/1.06	

- Remove the flaring tool and flare form, then inspect the end of the pipe for cracks and even flaring.

Step 4: Connect pipes

Connect the copper pipes to the indoor unit first, then connect it to the outdoor unit. You should first connect the low-pressure pipe, then the high-pressure pipe.

- When connecting the flare nuts, apply a thin coat of refrigeration oil to the flared ends of the pipes.
- Align the center of the two pipes that you will connect.
- Tighten the flare nut snugly by hand.
- Using a wrench, grip the nut on the unit tubing.
- While firmly gripping the nut, use a torque wrench to tighten the flare nut according to the torque values in above table.

NOTICE

Use both a spanner and a torque wrench when connecting or disconnecting pipes to/from the unit.

CAUTION

Ensure to wrap insulation around the piping. Direct contact with the bare piping may result in burns or frostbite.

- Make sure the pipe is properly connected. Over tightening may damage the bell mouth and under tightening may lead to leakage.

NOTICE

MINIMUM BEND RADIUS

Carefully bend the tubing in the middle according to the diagram below.

- DO NOT** bend the tubing more than 90° or more than 3 times.

Use appropriate tool

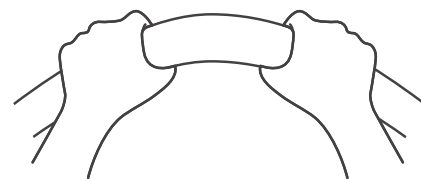

min-radius 10cm(3.9")

- After connecting the copper pipes to the indoor unit, wrap the power cable, signal cable and the piping together with binding tape.

NOTICE

DO NOT intertwine or cross the signal cable with any other wiring.

- Thread this pipeline through the wall and connect it to the outdoor unit.
- Insulate all the piping, including the valves of the outdoor unit.
- Open the stop valves of the outdoor unit to start the flow of the refrigerant between the indoor and outdoor unit.

⚠ CAUTION

Check to make sure there is no refrigerant leak after completing the installation work. If there is a refrigerant leak, ventilate the area immediately and evacuate the system (refer to the Air Evacuation section of this manual).

Air-Handler Air Conditioners Refrigerant Piping Connection

Correct Refrigerant piping Connecting installation methods

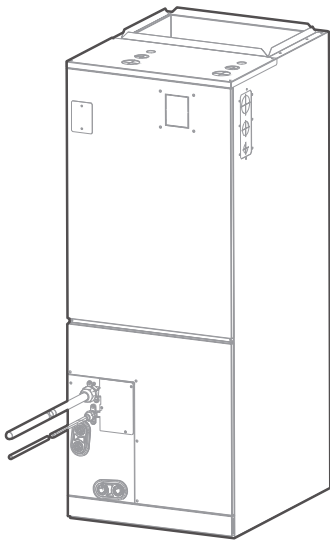

Plan 1

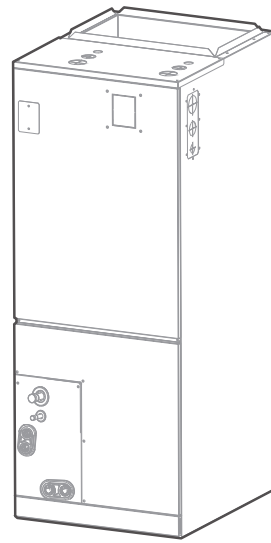

Plan 2

Heating performance

After the unit is installed, wrap the piping and brass fitting with foam tape.

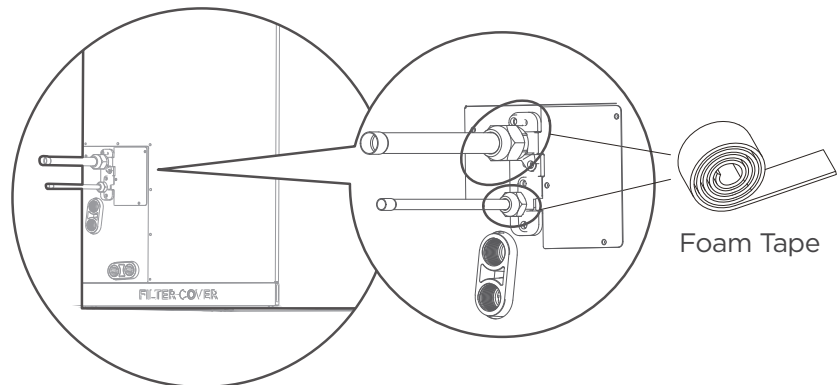

Foam Tape

INSTALLATION OF ELECTRIC AUXILIARY HEAT MODULE (ONLY FOR HEAT FUNCTION MODELS)

NOTICE

Installation must be performed by a licensed contractor. Please make necessary precaution when performing the installation operation.

Accessories

Name	Quantity	Name	Quantity
Manual	2	Silicone breaker cover	1
Foam gasket	1	Electric auxiliary heating wiring diagram	1
Screws	7	Circuit breaker label	1

Model size selection

For installations requiring supplemental heating, the optional Electric Auxiliary Heat Module is available in sizes from 3kW to 25kW to accommodate appropriate sizing given the specific heat load and electrical requirements of each installation. Please refer to the table below for selection of available sizes of each model, being sure to avoid improper matching.

MODEL (Btu/h)	3kW	5kW	8kW	10kW	15kW	20kW	25kW
18K	Y	Y	Y	Y	-	-	-
24K	-	Y	Y	Y	Y	-	-
30K	-	Y	Y	Y	Y	-	-
36K	-	Y	Y	Y	Y	Y	-
48K	-	-	Y	Y	Y	Y	-
60K	-	-	-	Y	Y	Y	Y

NOTICE

Only use matched modules certified for use with model. Please refer to the Electric Auxiliary Heat Model specification for additional details to ensure proper selection and installation.

Preparations for Installation

Before installation, please confirm the electric auxiliary heat module and supplied accessories are complete and free of any damage. Do not attempt to install if damage is present.

Electric Auxiliary Heat Module installation and Wiring Operation

Step 1

Open the upper cover.

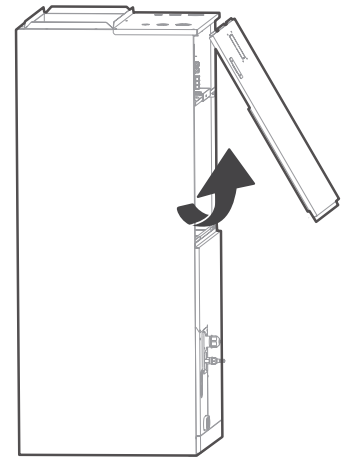

Step 2

Use tools to remove the knock-out holes of upper cover.

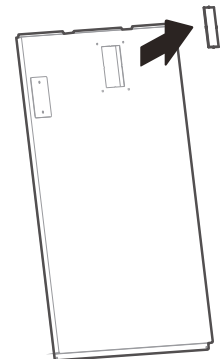

Step 3

Remove the terminal block and power wires, loosen the screws, and remove the electric auxiliary heating cover.

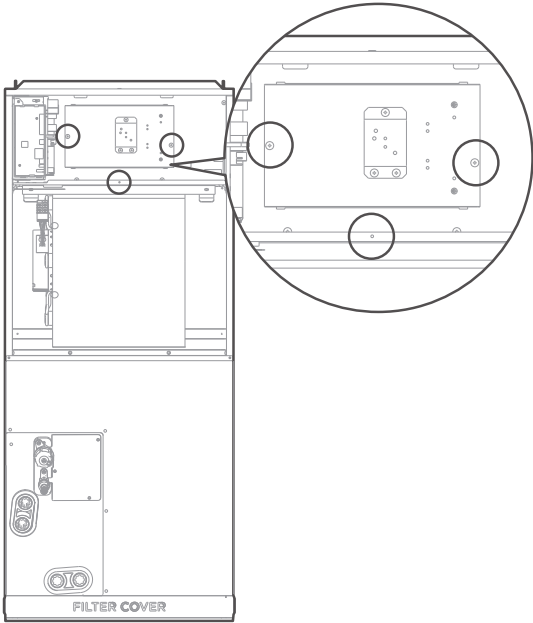

Step 4

Install the electric auxiliary heating assembly the front, and note that the support assembly must lock into the support holes in the back of the cabinet.

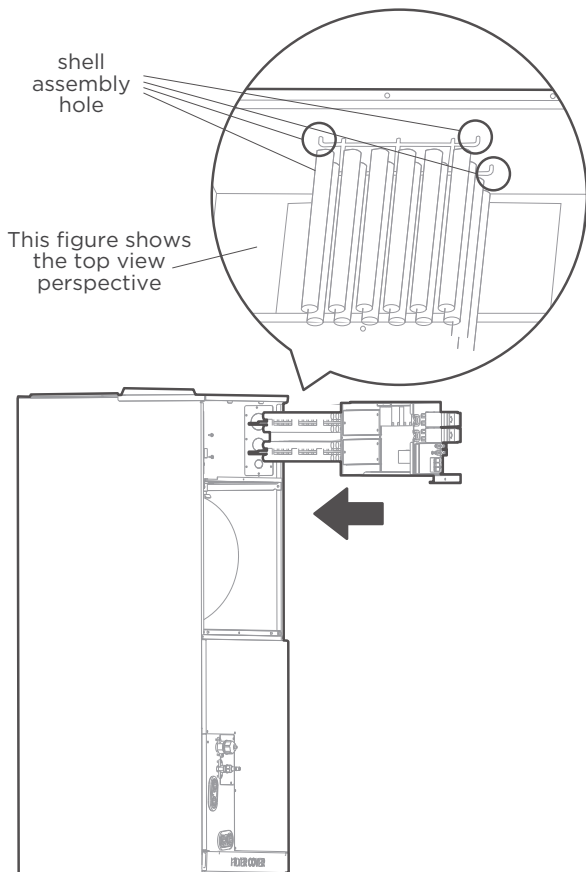

Step 5

Tighten the mounting screws.

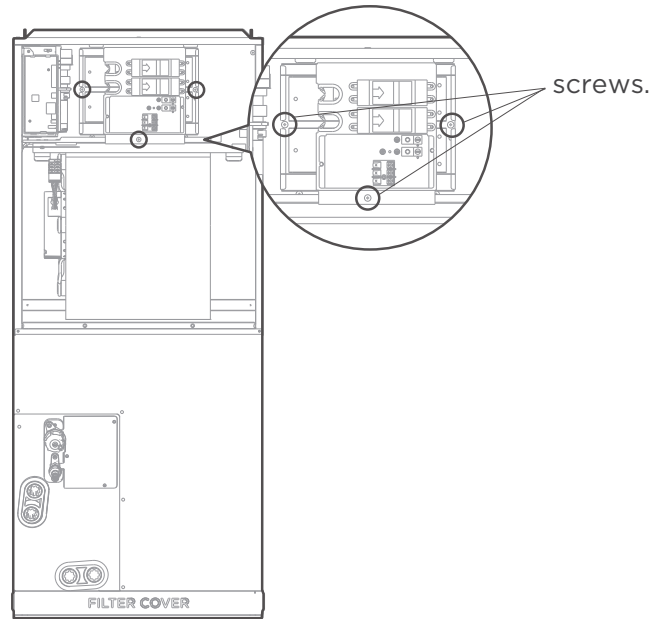

Step 6

Wire according to the wiring nameplate. Apply the wiring diagram to the inside cover wiring is completed for future reference and maintenance.

Step 7

Install the upper cover, and the silicone breaker cover.

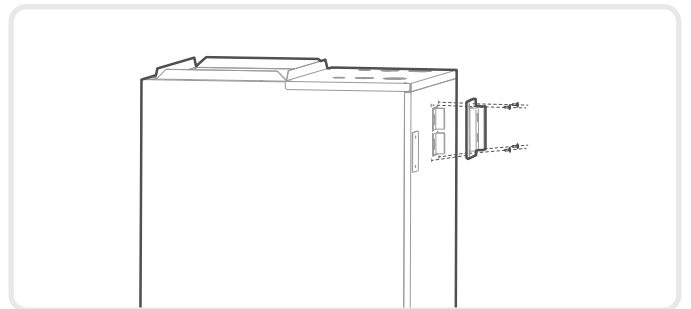

Step 8

After installing the electric auxiliary heat module, apply the circuit breaker label near the silicone breaker cover that was just applied.

CONFIRMATION OF INDOOR UNIT

NOTICE

Electric auxiliary heating wiring diagram packed with the accessories.
 If branch circuit wire length exceeds 100 ft, consult NEC 210-19a to determine maximum wire length.
 Use 2% voltage drop.

After the electric heating wiring is connected, please confirm before power on:

- Check all wiring and ensure secure connection of all wiring.
- Ensure that wire size is properly selected per NEC or local codes.

Specifications	Number of circuit breakers	Number of relays	Number of power cord groups	Number of power cord grounding screws
3kW	1	1	2	2
5kW	1	1	2	2
8kW	1	2	2	2
10kW	1	2	2	2
15kW	2	3	3	3
20kW	2	4	3	3
25kW	3	5	4	4

Units without electrical heat

UNIT SIZE	VOITS-PHASE	Rated current(A)	MIN CKT AMPS	BRANCH CIRCUIT	
				MIN WIRE SIZE AWG*	FUSE/CKT BKR AMPS
18K	208/230-1	2.0	2.5	14#	15.0
24K	208/230-1	3.0	4.0	14#	15.0
30K	208/230-1	3.5	4.5	14#	15.0
36K	208/230-1	4.0	5.0	14#	15.0
48K	208/230-1	6.0	7.5	14#	15.0
60K	208/230-1	7.0	9.0	14#	15.0

Use copper wire only to connect unit. If other than uncoated (non-plated) 75°C copper wire (solid wire for 10 AWG and smaller, stranded wire for larger than 10 AWG) is used consult applicable tables of the National Electric Code (ANSI/NFPA 70).

NOTICE

The specification may be different between different models ,please refer to indoor unit ' s nameplate.

Auxiliary Heater Electrical Date

Heater Part No.	Heater KW	Internal Circuit Protection	CIRCUIT 1 208/230V				CIRCUIT 2				CIRCUIT 2			
			Heater Amps	MCA (1)	MOC (2)	Heater Amps	MCA (1)	MOC (2)	Heater Amps	MCA (1)	MOC (2)	Heater Amps	MCA (1)	MOC (2)
EAH-03B(UL)	3	Ckt Bkr	10.8/12.0	14.0/16.0	15.0/20.0	/	/	/	/	/	/	/	/	/
EAH-05B(UL)	5	Ckt Bkr	18.0/20.0	23.0/27.0	25.0/30.0	/	/	/	/	/	/	/	/	/
EAH-08B(UL)	8	Ckt Bkr	28.8/32.0	37.0/42.0	40.0/45.0	/	/	/	/	/	/	/	/	/
EAH-10B(UL)	10	Ckt Bkr	36.0/40.0	46.0/53.0	50.0/60.0	/	/	/	/	/	/	/	/	/
EAH-15B(UL)	15	Ckt Bkr	18.0/20.0	23.0/27.0	25.0/30.0	36.0/40.0	46.0/53.0	50.0/60.0	36.0/40.0	46.0/53.0	50.0/60.0	/	/	/
EAH-20B(UL)	20	Ckt Bkr	36.0/40	46.0/53.0	50.0/60.0	36.0/40.0	46.0/53.0	50.0/60.0	36.0/40.0	46.0/53.0	50.0/60.0	/	/	/
EAH-25B(UL)	25	Ckt Bkr	18.0/20.0	23.0/27.0	25.0/30.0	36.0/40.0	46.0/53.0	50.0/60.0	36.0/40.0	46.0/53.0	50.0/60.0	36.0/40.0	46.0/53.0	50.0/60.0

Electric auxiliary heating wiring diagram

3KW/5KW HEAT KIT

: THERMAL CUT-OUT (Cut-off temperature 98°C, holding temperature 83°C, limiting temperature 410°C.)
 : THERMAL LINK, SELF-RESETTING (Break-off temperature 60 ± 3°C, reset temperature 43 ± 6°C.)

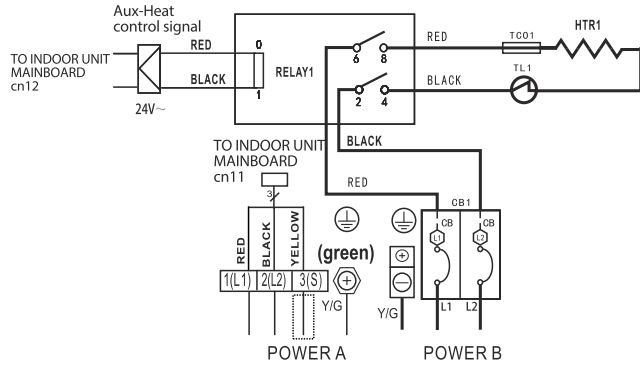

NOTE1: This symbol indicates the element is optional. The wiring type of the actual unit shall prevail.

NOTE2: Please attach the nameplate to the cover of the electric control box. All the round holes located on the plate represent numbers. Please refer to the Installation Manual for details.

NOTE3: TO BE WIRED IN ACCORDANCE WITH NEC AND LOCAL CODES.

NOTE4: POWER A, B, C, D ARE DIFFERENT POWERS.

The wiring mode of power supply A shall be based on the type of original wiring terminal of AHU; for type A, S position must be connected to the outdoor S; for type B, S position shall not be connected.

Round hole number	Relay number	Round hole number	Circuit breaker number
○	RELAY 1	○	CB1
○		○	
○		○	
○		○	



8KW/10KW HEAT KIT

: THERMAL CUT-OUT (Cut-off temperature 98°C, holding temperature 83°C, limiting temperature 410°C.)
 : THERMAL LINK, SELF-RESETTING (Break-off temperature 60 ± 3°C, reset temperature 43 ± 6°C.)

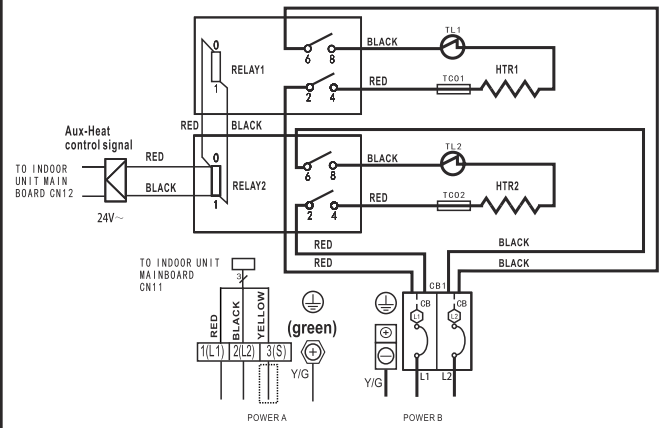

NOTE1: This symbol indicates the element is optional. The wiring type of the actual unit shall prevail.

NOTE2: Please attach the nameplate to the cover of the electric control box. All the round holes located on the plate represent numbers. Please refer to the Installation Manual for details.

NOTE3: TO BE WIRED IN ACCORDANCE WITH NEC AND LOCAL CODES.

NOTE4: POWER A, B, C, D ARE DIFFERENT POWERS.

The wiring mode of power supply A shall be based on the type of original wiring terminal of AHU; for type A, S position must be connected to the outdoor S; for type B, S position shall not be connected.

Round hole number	Relay number	Round hole number	Circuit breaker number
○	RELAY 1	○	CB1
○	RELAY 2	○	
○		○	
○		○	



15KW HEAT KIT

: THERMAL CUT-OUT (Cut-off temperature 98°C, holding temperature 83°C, limiting temperature 410°C.)
 : THERMAL LINK, SELF-RESETTING (Break-off temperature 60 ± 3°C, reset temperature 43 ± 6°C.)

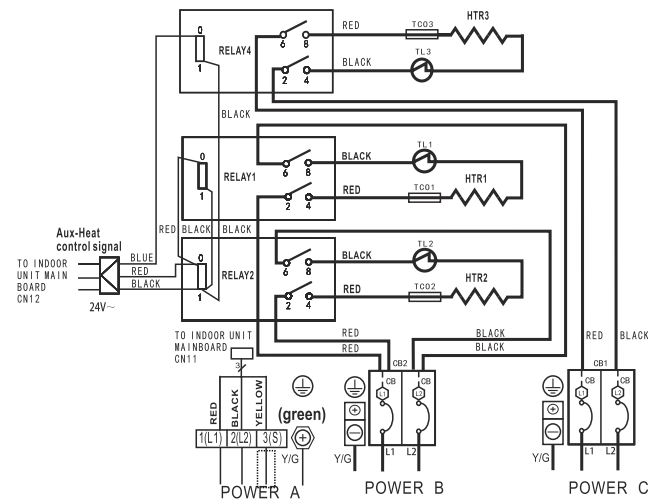

NOTE1: This symbol indicates the element is optional. The wiring type of the actual unit shall prevail.

NOTE2: Please attach the nameplate to the cover of the electric control box. All the round holes located on the plate represent numbers. Please refer to the Installation Manual for details.

NOTE3: TO BE WIRED IN ACCORDANCE WITH NEC AND LOCAL CODES.

NOTE4: POWER A, B, C, D ARE DIFFERENT POWERS.

The wiring mode of power supply A shall be based on the type of original wiring terminal of AHU; for type A, S position must be connected to the outdoor S; for type B, S position shall not be connected.

Round hole number	Relay number	Round hole number	Circuit breaker number
○	RELAY 1	○	CB1
○	RELAY 2	○	CB2
○	RELAY 4	○	
○		○	



20KW HEAT KIT

: THERMAL CUT-OUT (Cut-off temperature 98°C, holding temperature 83°C, limiting temperature 410°C.)
 : THERMAL LINK, SELF-RESETTING (Break-off temperature 60 ± 3°C, reset temperature 43 ± 6°C.)

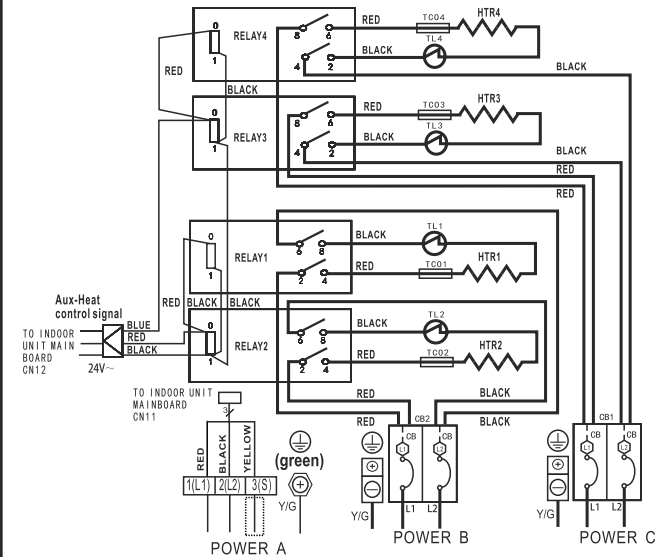

NOTE1: This symbol indicates the element is optional. The wiring type of the actual unit shall prevail.

NOTE2: Please attach the nameplate to the cover of the electric control box. All the round holes located on the plate represent numbers. Please refer to the Installation Manual for details.

NOTE3: TO BE WIRED IN ACCORDANCE WITH NEC AND LOCAL CODES.

NOTE4: POWER A, B, C, D ARE DIFFERENT POWERS.



The wiring mode of power supply A shall be based on the type of original wiring terminal of AHU; for type A, S position must be connected to the outdoor S; for type B, S position shall not be connected.

Round hole number	Relay number	Round hole number	Circuit breaker number
○	RELAY 1	○	CB1
○	RELAY 2	○	CB2
○	RELAY 3	○	
○	RELAY 4	○	



Electric auxiliary heating wiring diagram

25KW HEAT KIT

-  : THERMAL CUT-OUT(Cut-off temperature 98°C, holding temperature 83°C, limiting temperature 410°C.)
-  : THERMAL LINK, SELF-RESETTING(Break-off temperature 60 ± 3°C, reset temperature 43 ± 6°C.)

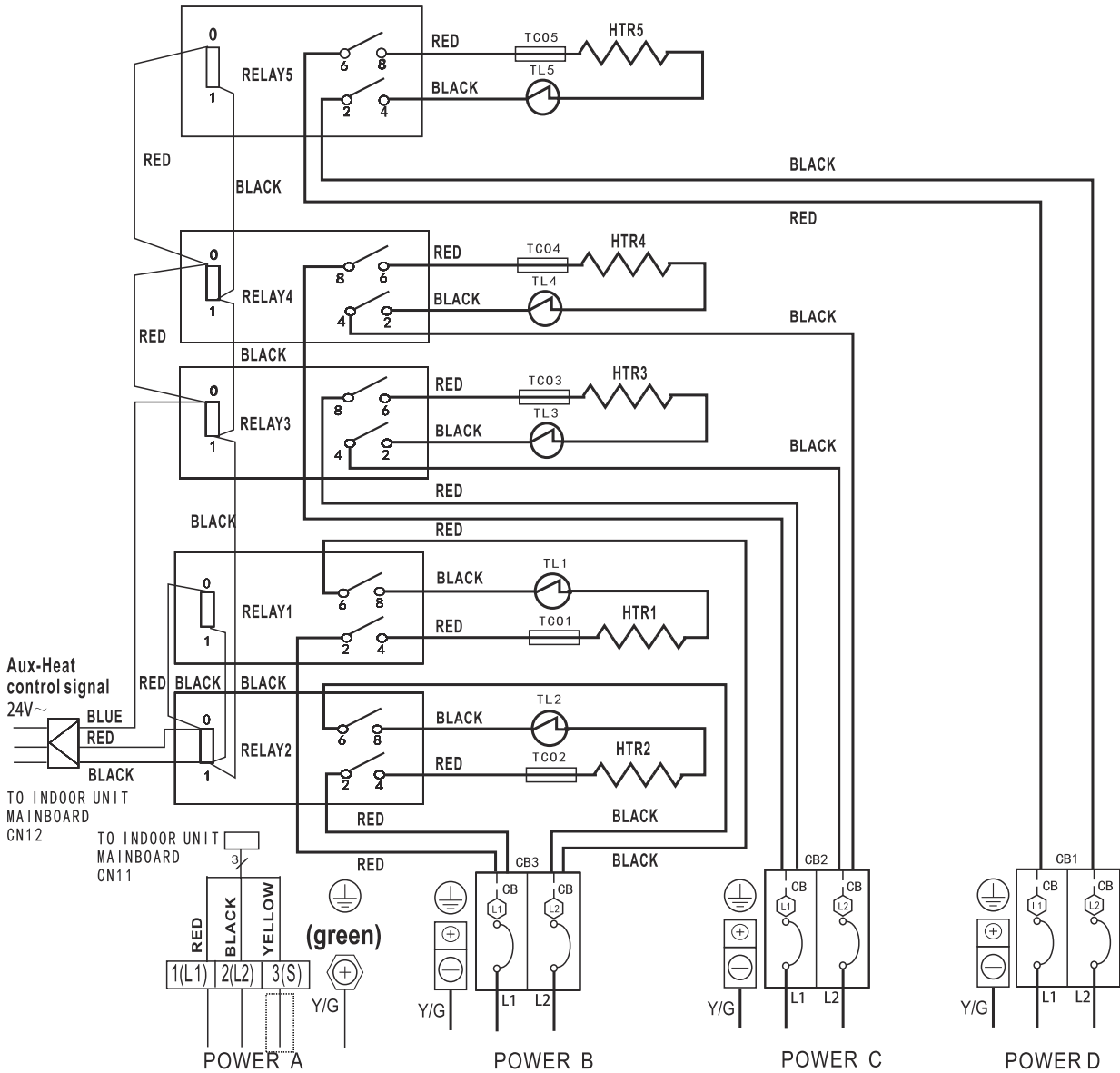

NOTE1:  This symbol indicates the element is optional. The wiring type of the actual unit shall prevail.

NOTE2: Please attach the nameplate to the cover of the electric control box. All the round holes located on the plate represent numbers. Please refer to the Installation Manual for details.

NOTE3: TO BE WIRED IN ACCORDANCE WITH NEC AND LOCAL CODES.
NOTE4: POWER A,B,C,D ARE DIFFERENT POWERS.

Round hole number	Relay number	Round hole number	Circuit breaker number
⊙	RELAY 1	⊙	CB1
⊙⊙	RELAY 2	⊙⊙	CB2
⊙⊙⊙	RELAY 3	⊙⊙⊙	CB3
⊙⊙⊙⊙	RELAY 4		
⊙⊙⊙⊙⊙	RELAY 5		

The wiring mode of power supply A shall be based on the type of original wiring terminal of AHU; for type A, S position must be connected to the outdoor S; for type B, S position shall not be connected.



OUTDOOR UNIT INSTALLATION

NOTICE

Install the unit by following local switches and regulations, there may be differ slightly between different regions.

Select the installation location of outdoor units

Before installing the outdoor unit, you must choose an appropriate location. The following are standards that will help you choose an appropriate location for the unit.

Proper installation locations meet the following standards:

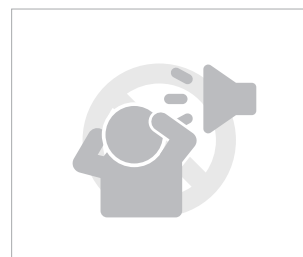
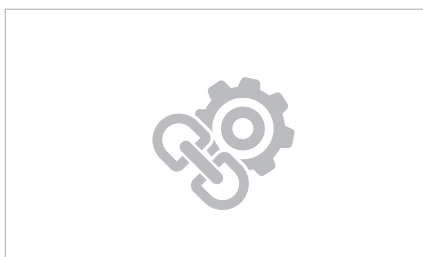
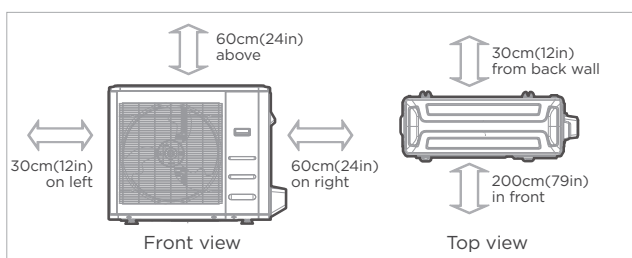

✓ Meets all spatial requirements shown in Installation Space Requirements above.

✓ Firm and solid—the location can support the unit and will not vibrate.

✓ Noise from the unit will not disturb other people.

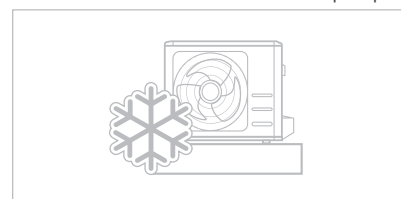
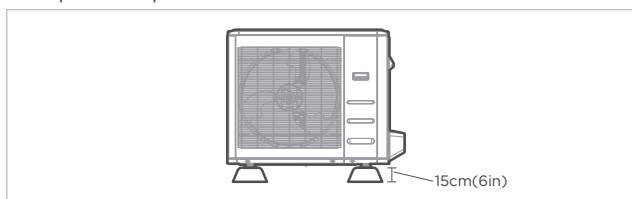

✓ The outdoor unit must be installed on risers of at least 15cm (6in) in height or per local code to get unit above local mean snow fall.

✓ Good air circulation and ventilation.

✓ Where snowfall is anticipated, take appropriate measures to prevent ice buildup and coil damage.

DO NOT install unit in the following locations:

⊘ Near an obstacle that will block air inlets and outlets.

⊘ Near animals or plants that will be harmed by hot air discharge.

⊘ Near a public street, crowded areas, or where noise from the unit will disturb others.

⊘ In a location that is exposed to large amounts of dust.

⊘ Near any source of combustible gas

CAUTION:

SPECIAL CONSIDERATIONS FOR EXTREME WEATHER

If the unit is exposed to heavy wind:

Install unit so that air outlet fan is at a 90° angle to the direction of the wind. If needed, build a barrier in front of the unit to protect it from extremely heavy winds. See Figures below.

If the unit is frequently exposed to heavy rain or snow:

Build a shelter above the unit to protect it from the rain or snow. Be careful not to obstruct air flow around the unit.

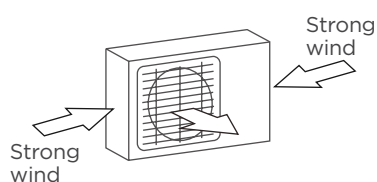

90° angle to the direction of the wind

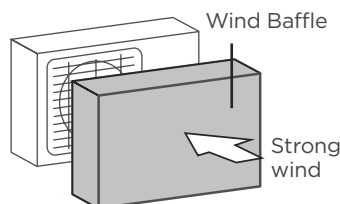

Build a wind Baffle to protect the unit

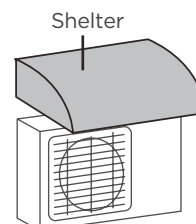

Build a shelter to protect the unit

Install drain fitting(Heat pump unit only)

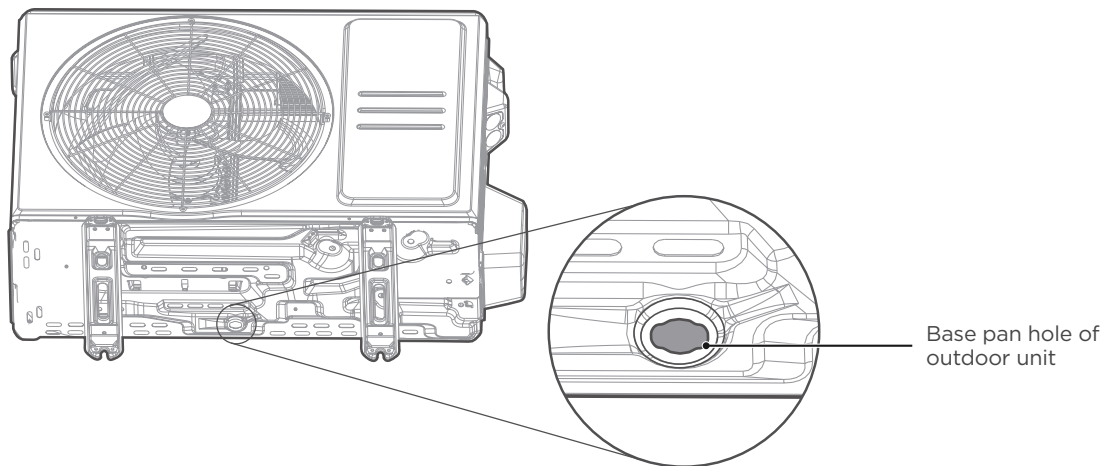

Step 1:

Find out the base pan hole of outdoor unit.

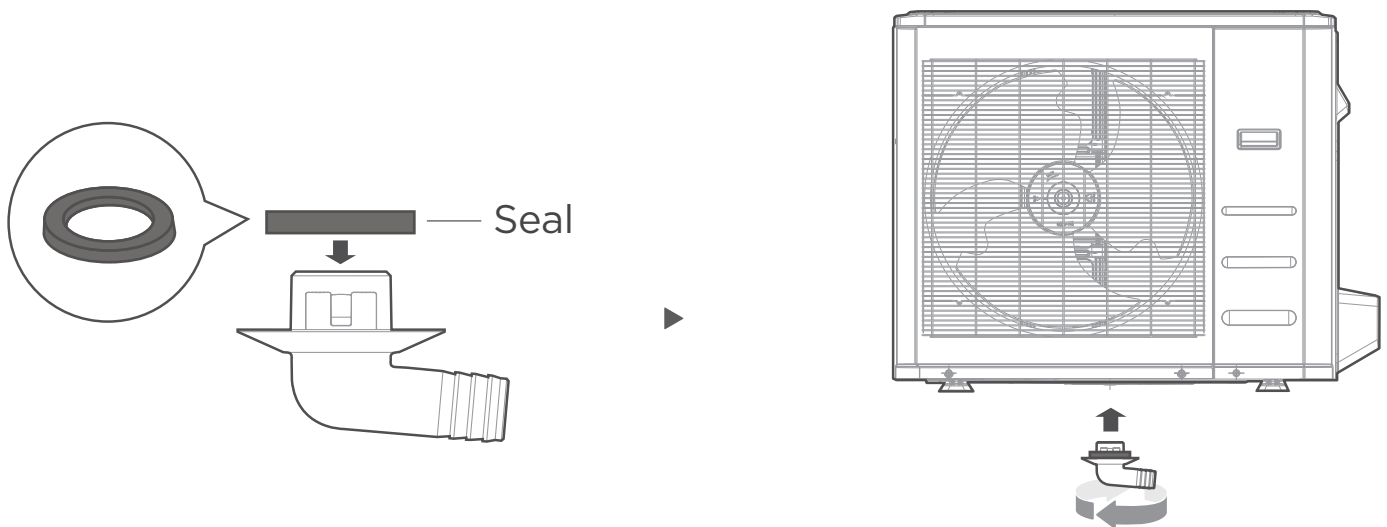

Step 2:

- Fit the rubber seal on the end of the drain fitting that will connect to the outdoor unit.
- Insert the drain fitting into the hole in the base pan of the unit. The drain fitting will click in place.
- Connect a drain hose extension (not included) to the drain fitting to redirect water from the unit during heating mode.

💡 IN COLD CLIMATES

In cold climates, make sure that the drain hose is as vertical as possible to ensure swift water drainage. If water drains too slowly, it can freeze in the hose and flood the unit.

Anchor outdoor unit

The outdoor unit can be anchored to the ground or to a wall-mounted bracket with bolt(M10). Prepare the installation base of the unit according to the dimensions below.

Outdoor Unit Types and Specifications

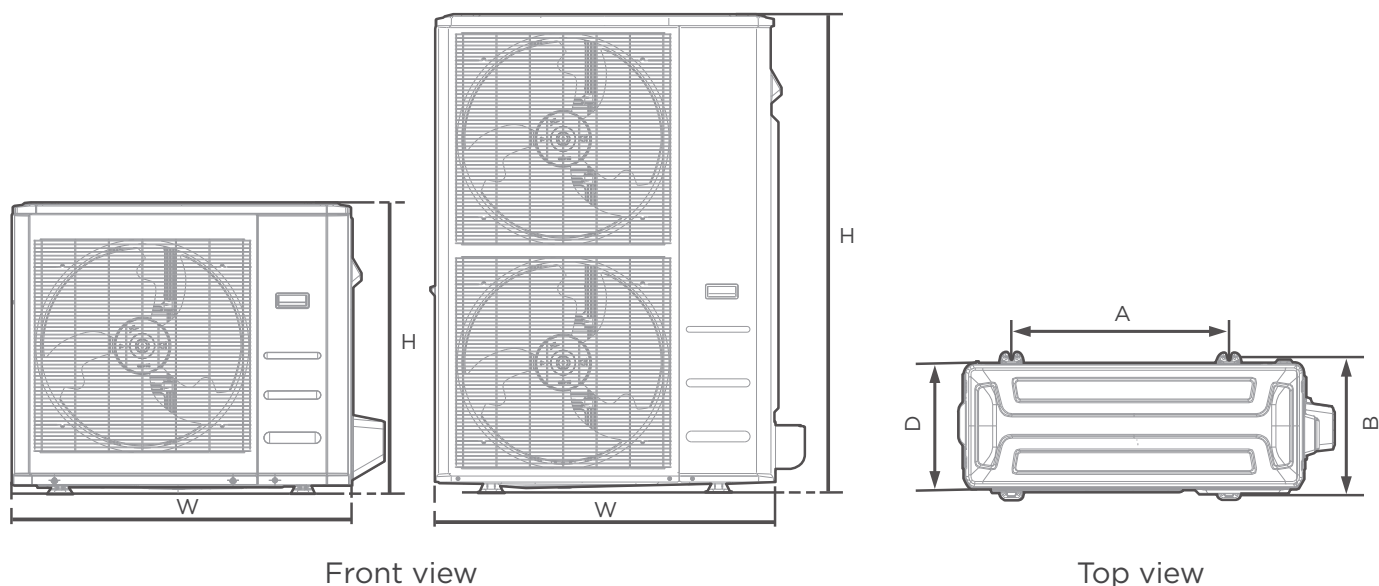

Outdoor Unit Dimensions						Mounting Dimensions			
W		H		D		A		B	
mm	inch	mm	inch	mm	inch	mm	inch	mm	inch
805	31-11/16	554	21-13/16	330	13	511	20-1/8	317	12-1/2
890	35	673	26-1/2	342	13-15/32	663	26-1/8	354	13-15/16
946	37-1/4	810	31-29/32	410	16-5/32	673	26-1/2	403	15-7/8
952	37-1/2	1333	52-1/2	415	16-11/32	634	24-35/36	404	15-29/32

(unit: mm/inch)

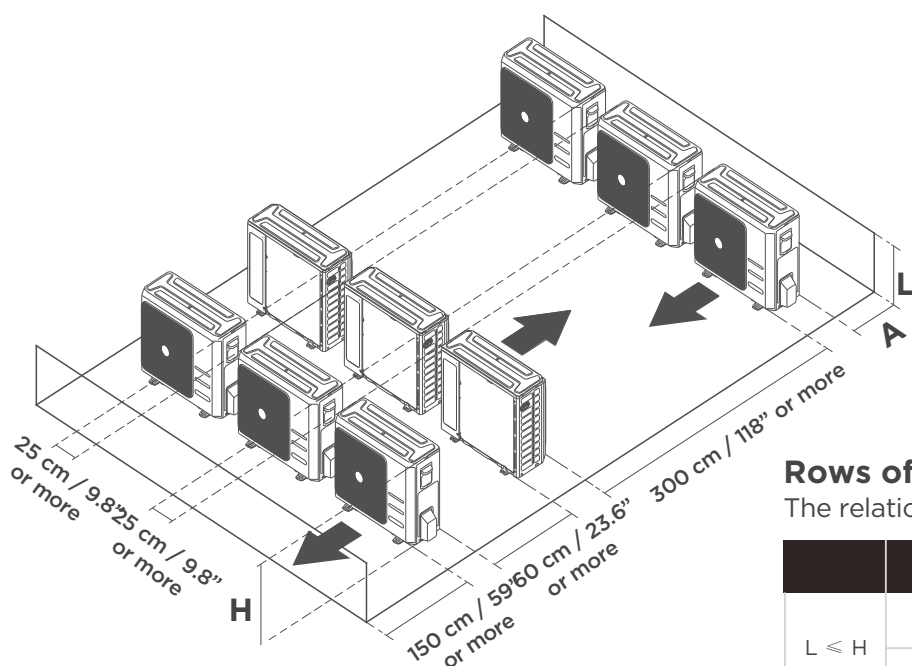

Rows of series installation

The relations between H, A and L are as follows.

	L	A
L < H	$L \leq 1/2H$	25 cm / 9-13/16in or more
	$1/2H < L \leq H$	30 cm / 11-13/16in or more
L > H	Can not be installed	

If you will install the unit on the ground or on a concrete mounting platform, DO THE FOLLOWING:

- Mark the positions for four expansion bolts based on dimensions chart.
- Pre-drill holes for expansion bolts.
- Place a nut on the end of each expansion bolt.
- Hammer expansion bolts into the pre-drilled holes.
- Remove the nuts from expansion bolts, and place outdoor unit on bolts.
- Put washer on each expansion bolt, then replace the nuts.
- Using a wrench, tighten each nut until snug.

 WARNING

WHEN DRILLING INTO CONCRETE, EYE PROTECTION IS RECOMMENDED AT ALL TIMES.

If you will install the unit on a wall-mounted bracket, DO THE FOLLOWING:

- Mark the position of bracket holes based on dimensions chart.
- Pre-drill the holes for the expansion bolts.
- Place a washer and nut on the end of each expansion bolt.
- Thread expansion bolts through holes in mounting brackets, put mounting brackets in position, and hammer expansion bolts into the wall.
- Check that the mounting brackets are level.
- Carefully lift unit and place its mounting feet on brackets.
- Bolt the unit firmly to the brackets.
- If allowed, install the unit with rubber isolator pads to reduce vibrations and noise.

 CAUTION

Make sure that the wall is made of solid brick, concrete, or of similarly strong material. The wall must be able to support at least four times the weight of the unit.

WIRING PRECAUTIONS

⚠ WARNING

BEFORE PERFORMING ANY ELECTRICAL WORK, READ THESE WARNINGS.

- All wiring must comply with local and national electrical codes, regulations and must be installed by a licensed electrician.
- All electrical connections must be made according to the Electrical Connection Diagram located on the panels of the indoor and outdoor units.
- If there is a serious safety issue with the power supply, stop work immediately. Explain your reasoning to the client, and refuse to install the unit until the safety issue is properly resolved.
- Power voltage should be within 90-110% of rated voltage. Insufficient power supply can cause malfunction, electrical shock, or fire.
- Installation of an external surge suppressor at the outdoor disconnect is recommended.
- If connecting power to fixed wiring, a switch or circuit breaker that disconnects all poles and has a contact separation of at least 1/8in (3mm) must be incorporated in the fixed wiring. The qualified technician must use an approved circuit breaker or switch.
- Only connect the unit to an individual branch circuit. Do not connect another appliance to that circuit.
- Make sure to properly ground the air conditioner.
- Every wire must be firmly connected. Loose wiring can cause the terminal to overheat, resulting in product malfunction and possible fire.
- Do not let wires touch or rest against refrigerant tubing, the compressor, or any moving parts within the unit.
- To avoid getting an electric shock, never touch the electrical components soon after the power supply has been turned off. After turning off the power, always wait 10 minutes or more before you touch the electrical components.
- Make sure that you do not cross your electrical wiring with your signal wiring.
- This may cause distortion, interference or possibly damage to circuit boards.
- No other equipment should be connected to the same power circuit.
- Connect the outdoor wires before connecting the indoor wires.

⚠ WARNING

BEFORE PERFORMING ANY ELECTRICAL OR WIRING WORK, TURN OFF THE MAIN POWER TO THE SYSTEM.

OUTDOOR UNIT WIRING

⚠ WARNING

Before performing any electrical or wiring work, turn off the main power to the system.

Step 1: Prepare the cable for connection.

1. You must first choose the right cable size.
2. Using wire strippers, strip the rubber jacket from both ends of the signal cable to reveal approximately 15cm (5.9") of wire.
3. Strip the insulation from the ends.
4. Stranded wire requires u-lugs or ring terminals to be crimped onto the ends of the wire.

💡 NOTICE

- When connecting the wires, strictly follow the wiring diagram found inside the electrical box cover.
- Choose the cable type according to the local electrical switches and regulations.
- Please choose the right cable size according to the Minimum Circuit Ampacity indicated on the nameplate of the unit.

Step 2: Remove the electric cover.

Remove the electric cover of the outdoor unit. If there is no cover on the outdoor unit, take off the bolts from the maintenance board and remove the protection board.

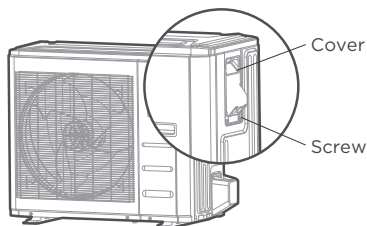

Step 3: Connect the u-lugs to the terminals

Match the wire colors/labels with the labels on the terminal block. Firmly screw the u-lug of each wire to its corresponding terminal.

4. Clamp down the cable with the cable clamp.
5. Insulate unused wires with electrical tape. Keep them away from any electrical or metal parts.
6. Reinstall the cover of the electric control box.

In North America

1. Remove the wire cover from the unit by loosening the 3 screws.
2. Remove caps on the conduit panel.
3. Mount the conduit tubes(not included) on the caonduit panel.
4. Properly connect both the power supply and low voltage lines to the corresponding terminals on the terminal block.
5. Ground the unit in accordance with local switches.
6. Be sure to size each wire allowing several inches longer than the required length for wiring.

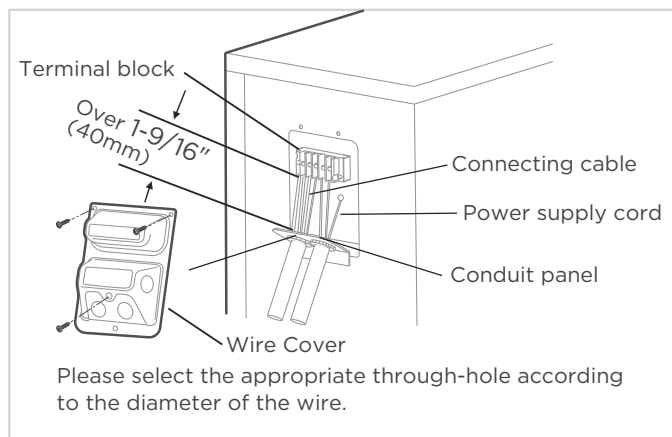

⚠ WARNING

ISOLATE THE POWER SUPPLY LEADS AND COMMUNICATION LEADS BY THE STRAIN RELIF AND KEEP POWER SUPPLY LEADS AWAY FROM COMMUNICATION LEADS.

INDOOR UNIT WIRING

⚠ CAUTION

- While connecting the wires, please strictly follow the wiring diagram.
- The refrigerant circuit can become very hot. Keep the interconnection cable away from the copper tube.

Step 1: Prepare the cable for connection.

1. Using wire strippers, strip the insulating jacket from both ends of the signal cable to reveal about 15cm (5.9") of the wire.
2. Strip the insulation from the ends of the wires.

Step 2: Open the front panel of the indoor unit.

Using a screwdriver, remove the cover of the electric control box on your indoor unit.

Step 3: Connect the wires to the terminals.

1. Thread the power cable and the signal cable through the wire outlet
2. Match the wire colors/labels with the labels on the terminal block. Firmly screw the wires of each wire to its corresponding terminal. Refer to the Serial Number and Wiring Diagram located on the cover of the electric control box.

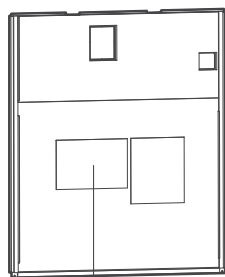

Wiring diagram

Type A

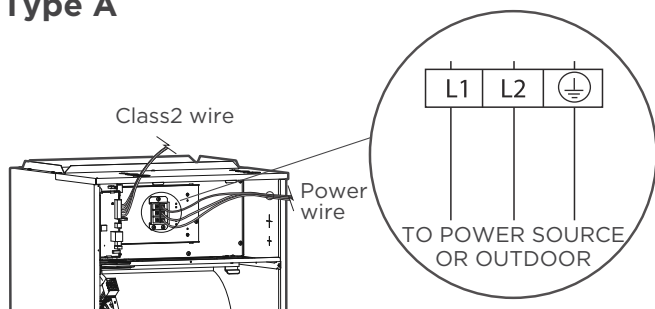

Type B

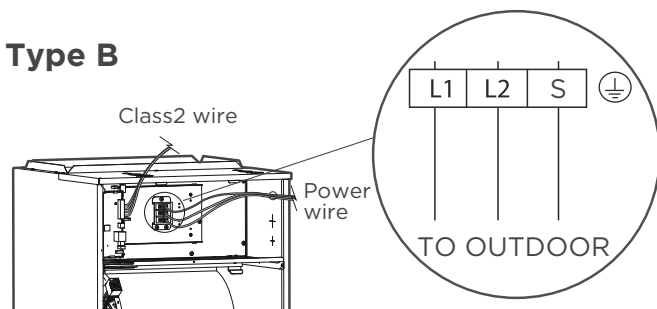

⚠ WARNING

ISOLATE THE POWER SUPPLY LEADS AND COMMUNICATION LEADS BY THE STRAIN RELIF AND KEEP POWER SUPPLY LEADS AWAY FROM COMMUNICATION LEADS.

3. Clamp down the cable with the cable clamp. The cable must not be loose or pull on the u-lugs.
4. Reattach the electric box cover.
5. Clamp down the cable with the cable clamp. The cable must not be loose or pull on the u-lugs.
6. Reattach the electric box cover

⚠ CAUTION

- While connecting the wires, please strictly follow the wiring diagram.
- The refrigerant circuit can become very hot. Keep the interconnection cable away from the copper tube.

SPECIFIC WIRING METHODS

⚠ WARNING

Please refer to the wiring nameplate for the wiring method. Do not connect the power cord to the communication line, as this may damage the system.

Connection method A:

Refer to the wiring method of internal and external machine communication and wired controller as follows:

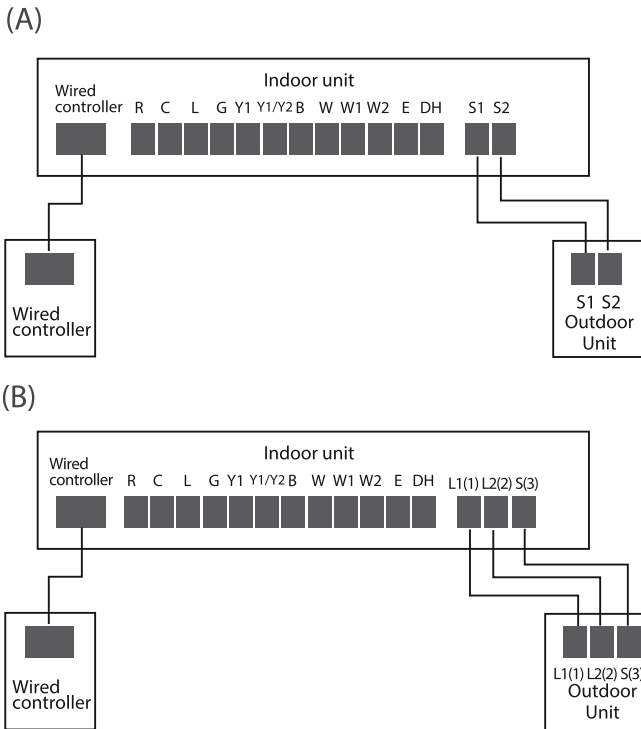

Connection method B:

To use a 24V thermostat, you need to refer to the following wiring:

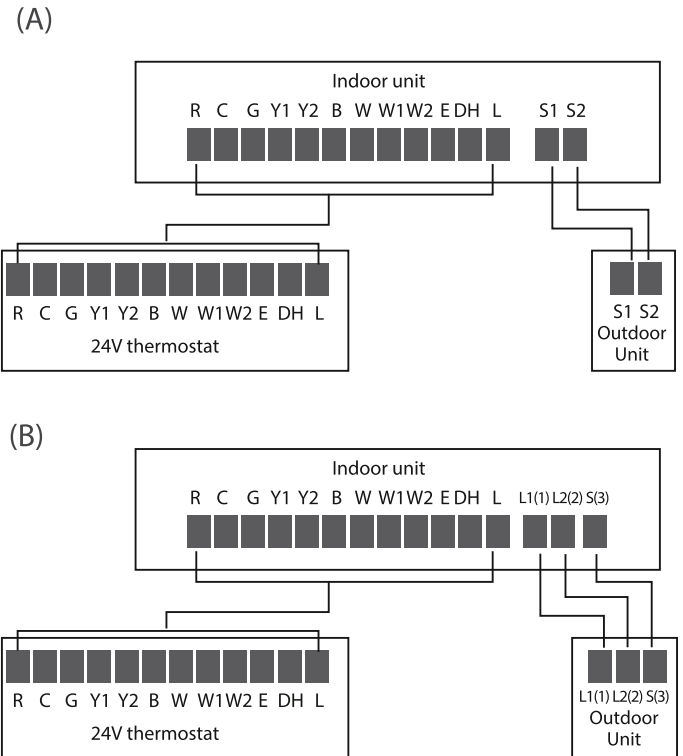

💡 NOTICE

The wiring method of the thermostat and the internal machine refers to the wiring of the non-communication scheme.

Connection method C:

Cooling and Fixed-speed Type Only System
Wiring Diagram:

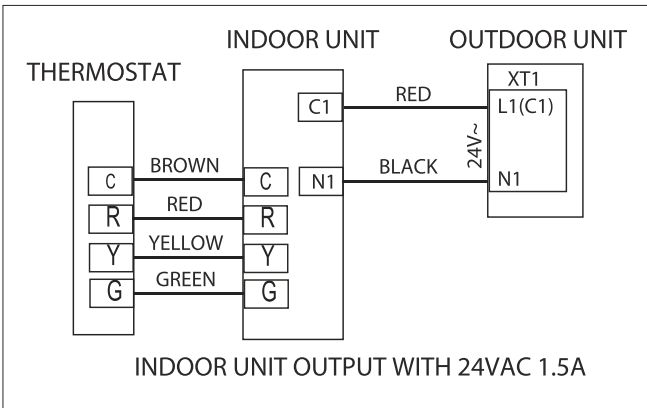

NOTICE

Suggestion: It is suggested that you use was a thermostat from Honeywell, series of non-programmable thermostats, including the TH5220D.

Optional function wiring:

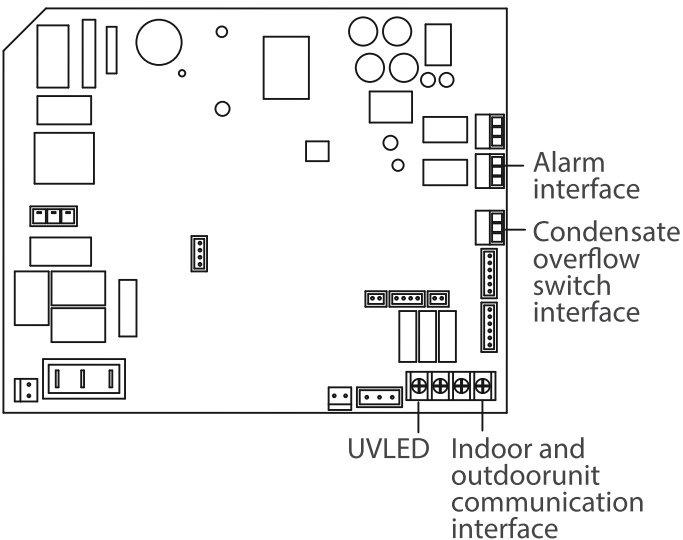

Condensate overflow switch:

The unit will accommodate a remote condensate overflow switch. To enable, remove jumper J1, and connect the installer provided condensate overflow device to CN5 per below. When an overflow condition is present, the device should open connection signaling the unit to turn off the system.

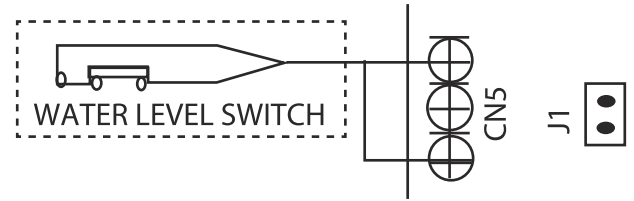

The fault warning:

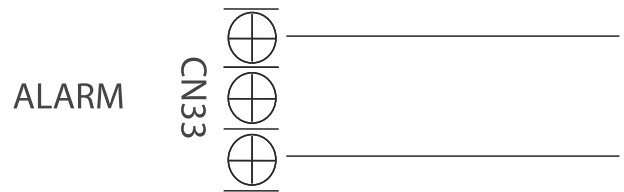

Alarm output:

An alarm output (CN33) can be utilized if actions are required when a fault is present. This is a passive outlet port, so you will need to input a voltage signal. The relay is normally-open for normal operation, and closed when a fault condition is active.

Humidifier control:

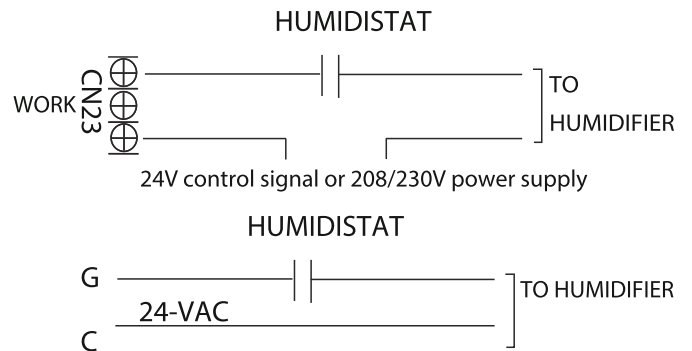

To connect a humidifier, utilize the passive signal "WORK" output (CN23) port as well as the G and C wires on the controller, and wire the humidistat and humidifier per above wiring diagram. When the fan is running, the CN23 relay will be closed, which will allow power to the humidifier when the humidistat is below humidity setpoint. If the thermostat or zone controller has an HUM interface, connect the humidifier directly to the HUM and C ports.

Dehumidification control wiring

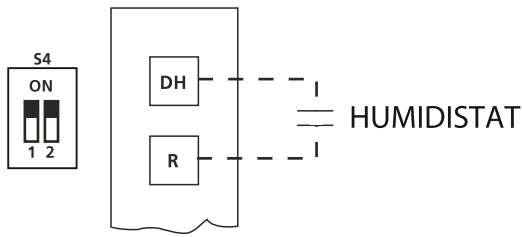

Dehumidification control requires external Humidistat at DH and R. Set S4-2 as OFF. When the humidity rises and exceeds the set value of the Humidistat, the 24V signal of DH changes to 0V, the cooling system starts the dehumidification operation, and the air volume drops to 80% of the nominal cooling air volume.

UV, fresh air or ion generator wiring



24V control signal or 208/230V power supply

The WORK port is linked with the fan. When the fan is running, the relay is closed; if an active 24V signal is required, it can be directly connected to the G and C ports.

Control logic

Indoor unit connector

Connector	Purpose
R	24V Power Connection
C	Common
G	Fan Control
Y1	Low Cooling
Y/Y2	High Cooling
B	Heating Reversing Valve
W	Heating control
W1	Stage 1 Electric Heating
W2	Stage 2 Electric Heating
E/AUX	Emergency Heating
DH/DS/BK	Dehumidification/Zoning control
L	System Fault Signal

LED display

The control displays unit status as well as any active fault codes on the LED display. If the unit is functioning normally, the LED will display current temperature setpoint. When a fault code is active, the display will flash quickly the active fault code. Please refer to the fault code table located in the troubleshooting section of the manual for detailed fault code information.

KEY1 Instructions (For Wired Controller only)

- Press KEY1 to enter the forced automatic mode, press KEY1 again to enter the forced cooling mode (LED display FC), and press KEY1 again to shut down.
- Keep pressing KEY1 under forced cooling mode (LED display FC) 5s to enter forced defrost mode.

DIP switch definitions

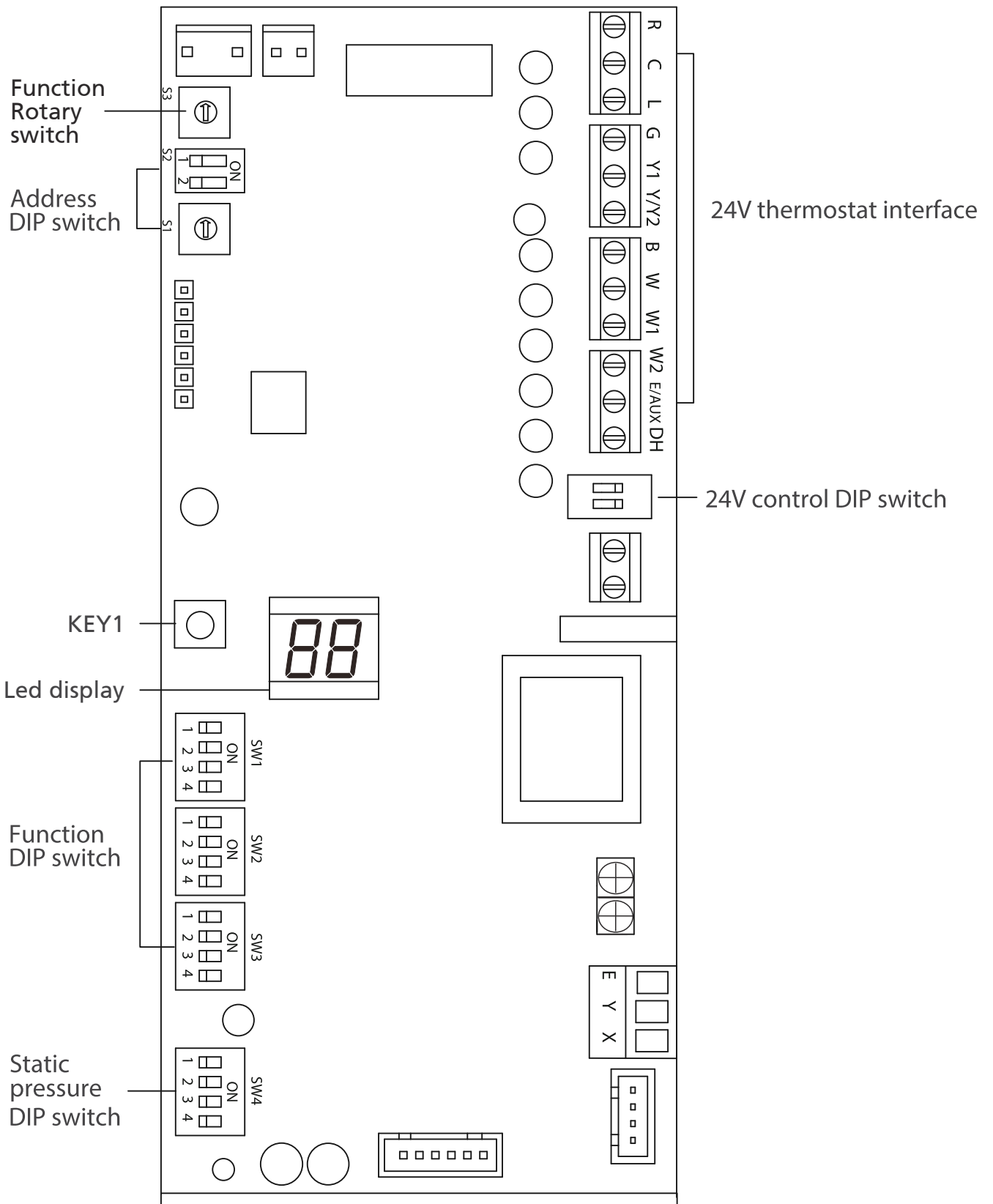

Function DIP switch settings:

The 24V thermostat mode needs to refer to the following settings:

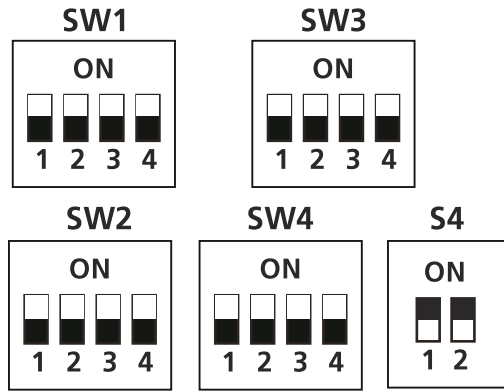

SW4-1	000 is the default 000/001/010/011/100/101/110/111, internal machines with different abilities, electric heating and PSC classification for use.
SW4-2	
SW4-3	

Indoor unit dial code

Function combination table of SW1-1 and SW1-4:

SW1	Control type	Stand alone or full system
	Free match	Free match
	Wired controller	Full system
	24V Thermostat	Full system
	24V Thermostat	Stand alone

No.	Dial Code	Control Scenario	Function	ON	OFF	Note
1	SW1-2	1,2,3	Anti-cold blow protection option	NO	[Default] YES	
2	SW1-3	1,2,3	Single cooling / heating and and cooling options	Cooling	[Default] Cooling & Heating	
3	SW2-1	1	Compressor Running (demand working with heat pump+ Electric heat)	Compressor slower speed	[Default] Faster Compressor	Only affects compressor and W1
4	SW2-1	2	Temperature differential to activate first stage auxiliary heat(the GAP of T1 and Ts),Wire controller demand with heat pump+Electric heat working together	2°F (1°C)	[Default] 4°F (2°C)	
5	SW2-2	2	Electric heat on delay	YES	[Default]NO	
6	SW2-3	2	Electric auxiliary heating delay to start time	30 minutes	[Default] 15 minutes	Based on SW2-2 is ON
7	SW2-4	1	Compressor	The operation of heat pump is limited by the outdoor temperature, and the operation of auxiliary heat is not limited.The system makes judgments according to the following rules: 1) The compressor can be operated when the outdoor temperature is \geq S3 DIP switch temperature +2 °C. 2) The compressor cannot be operated when the outdoor temperature is lower than the S3 DIP switch temperature.	[Default]The operation of heat pump is limited by the outdoor temperature, and the operation of auxiliary heat is not limited. The system makes judgments based on the following rules: 1) The compressor cannot be operated when the outdoor temperature is lower than the S3 DIP switch. 2) The compressor can be operated when the outdoor temperature is \geq S3 DIP switch temperature +2 °C.	SW2-4 and S3 need to working together
8	SW2-4	2	Compressor/Auxiliary heat outdoor ambient lockout	The operation of heat pump is limited by the outdoor temperature, and the operation of auxiliary heat is not limited.The system makes judgments according to the following rules: 1) The compressor can be operated when the outdoor temperature is \geq S3 DIP switch temperature +2 °C. 2) The compressor cannot be operated when the outdoor temperature is lower than the S3 DIP switch temperature.	[Default]Only one heat pump or auxiliary heat can be operated .The system makes judgments according to the following rules: 1) When the outdoor temperature is lower than the S3 DIP switch temperature,the compressor is not allowed to operated, but auxiliary heat is allowed to operated ; 2) When the outdoor temperature is \geq S3 DIP switch temperature +2(°C), the compressor can be operated, but auxiliary heat cannot be operated.	
9	Rotary Switch S3	1,2	Set outdoor temperature Limitation (for auxiliary heating or compressor)	Table A		
10	SW3-1	1	Maximum continuous runtime allowed before system automatically stages up capacity to satisfy set point. This adds 1 to 5°F to the user set point in the calculated control point to increase capacity and satisfy user set point	30 minutes	[Default] 90 minutes	
11	SW3-2	1	Cooling and heating Y/Y2 temperature differential adjustment.	Compressor slower speed	[Default] Faster Compressor	Only affects compressor
12	SW3-3	1	Compressor Running (demand working with heat pump+ Electric heat)	Compressor slower speed	[Default] Faster Compressor	Only affects compressor and W2
13	SW3-3	2	Temperature differential to activate second stage auxiliary heating(the GAP of T1 and Ts)Wire controller demand with heat pump+Electric heat working together	4°F (2°C)	[Default] 6°F (3°C)	
14	SW3-4	1,3	Fan speed of cooling mode when 24V Thermostat is applied for.	Turbo	High	

15	SW4	1,2,3	Electric heat nominal CFM adjustment	Available settings are 000/001/010/011. Each digit corresponds an individual switch position. For example [SW4-1 OFF, SW4-2 ON, SW4-3 OFF] = 010 See table 11 for the corresponding CFM adjustment	
16	S4-1	1,3	Default ON	[Default] For single stage supplemental heat, W1 and W2 are connected	For dual stage supplemental heat, W1 and W2 are controlled independently.
17	S4-2	1,3	DH function selection	[Default] Dehumidification control not available	Dehumidification feature is enabled through thermostat

Table A

Control Scenario	24V Tstat, S1+S2	1
	Wired Controller S1+S2	2
	Full 24V	3

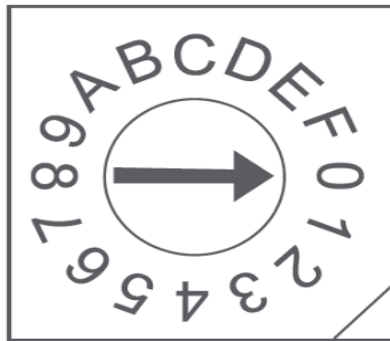

S3	S3 (°F)	S3 (°C)
0	OFF	OFF
1	-22	-30
2	-18	-28
3	-15	-26
4	-11	-24
5	-8	-22
6	-4	-20
7	3	-16
8	10	-12
9	18	-8
A	25	-4
B	32	0
C	36	2
D	39	4
E	43	6
F	46	8

Address DIP switch:

Address dialing S1+S2: When the user uses the centralized controller, the address dialing is required.

Network address: The address silkscreen is NET address, which is composed of a 16-bit address rotary code S2 plus a two-digit DIP switch S1 [Set during engineering installation, no network function does not need to be set]

When S2 is 00 (the dialing code is not connected), the network address value is the value of S2;

When S2 is 10 (corresponding to the switch of the hardware connected to the 10K resistor), the network address value is S2 plus 32;

Determined by dial code S2 1-10K 2-5.1K

When S2 is 01 (corresponding to the dial code of the 5.1K resistor connected to the hardware is turned on), the network address value is the value of S2 plus 16;

When S2 is 11 (all dialing codes are on), the network address value is the value of S2 plus 48.

Determined by dial code S2 1-10K 2-5.1K

Dial code selection	Website address
	S2 + 48
	S2 + 32
	S2 + 16
	S2

Air volume table

Capacity	External Static Pressure Range	Fan speed	Electric heater kit	24V thermostat		Wired controller		Airflow volume (CFM)
				DIP Switch	24V terminal engaged	DIP Switch	Mode	
18K (1.5 Ton)	0 - 0.80 in. w.g.	Cooling Turbo	—	SW3-4=ON	Y2/Y	—	Cool	618
		Cooling High	—	SW3-4=OFF	Y2/Y	—	Cool	576
		Cooling Medium	—	—	Y1	—	Cool	529
		Cooling Low	—	—	—	—	Cool	488
		Heat Pump Turbo	—	—	—	—	Heat	565
		Heat Pump High	—	—	B+Y2/Y, W	—	Heat	541
		Heat Pump Medium	—	—	Y1	—	Heat	435
		Heat Pump Low	—	—	—	—	Heat	400
		Electric heater kit 0(Default)	10KW	SW4-1=OFF SW4-2=OFF SW4-3=OFF	W1, W2, AUX	SW4-1=OFF SW4-2=OFF SW4-3=OFF	Heat + AUX, AUX	653
		Electric heater kit 1	10KW, 8KW	SW4-1=OFF SW4-2=OFF SW4-3=ON	W1, W2, AUX	SW4-1=OFF SW4-2=OFF SW4-3=ON	Heat + AUX, AUX	624
		Electric heater kit 2	8KW	SW4-1=OFF SW4-2=ON SW4-3=OFF	W1, W2, AUX	SW4-1=OFF SW4-2=ON SW4-3=OFF	Heat + AUX, AUX	594
		Electric heater kit 3	5KW, 3KW	SW4-1=OFF SW4-2=ON SW4-3=ON	W1, W2, AUX	SW4-1=OFF SW4-2=ON SW4-3=ON	Heat + AUX, AUX	565
24K (2 Ton)	0 - 0.80 in. w.g.	Cooling Turbo	—	SW3-4=ON	Y2/Y	—	Cool	824
		Cooling High	—	SW3-4=OFF	Y2/Y	—	Cool	759
		Cooling Medium	—	—	Y1	—	Cool	694
		Cooling Low	—	—	—	—	Cool	629
		Heat Pump Turbo	—	—	—	—	Heat	788
		Heat Pump High	—	—	B+Y2/Y, W	—	Heat	753
		Heat Pump Medium	—	—	Y1	—	Heat	641
		Heat Pump Low	—	—	—	—	Heat	524
		Electric heater kit 0(Default)	15KW	SW4-1=OFF SW4-2=OFF SW4-3=OFF	W1, W2, AUX	SW4-1=OFF SW4-2=OFF SW4-3=OFF	Heat + AUX, AUX	871
		Electric heater kit 1	15KW, 10KW	SW4-1=OFF SW4-2=OFF SW4-3=ON	W1, W2, AUX	SW4-1=OFF SW4-2=OFF SW4-3=ON	Heat + AUX, AUX	841
		Electric heater kit 2	10KW, 8KW	SW4-1=OFF SW4-2=ON SW4-3=OFF	W1, W2, AUX	SW4-1=OFF SW4-2=ON SW4-3=OFF	Heat + AUX, AUX	818
		Electric heater kit 3	5KW	SW4-1=OFF SW4-2=ON SW4-3=ON	W1, W2, AUX	SW4-1=OFF SW4-2=ON SW4-3=ON	Heat + AUX, AUX	788
30K (2.5 Ton)	0 - 0.80 in. w.g.	Cooling Turbo	—	SW3-4=ON	Y2/Y	—	Cool	988
		Cooling High	—	SW3-4=OFF	Y2/Y	—	Cool	894
		Cooling Medium	—	—	Y1	—	Cool	806
		Cooling Low	—	—	—	—	Cool	712
		Heat Pump Turbo	—	—	—	—	Heat	918
		Heat Pump High	—	—	B+Y2/Y, W	—	Heat	876
		Heat Pump Medium	—	—	Y1	—	Heat	665
		Heat Pump Low	—	—	—	—	Heat	453
		Electric heater kit 0(Default)	15KW	SW4-1=OFF SW4-2=OFF SW4-3=OFF	W1, W2, AUX	SW4-1=OFF SW4-2=OFF SW4-3=OFF	Heat + AUX, AUX	1088
		Electric heater kit 1	15KW, 10KW	SW4-1=OFF SW4-2=OFF SW4-3=ON	W1, W2, AUX	SW4-1=OFF SW4-2=OFF SW4-3=ON	Heat + AUX, AUX	1029
		Electric heater kit 2	10KW, 8KW	SW4-1=OFF SW4-2=ON SW4-3=OFF	W1, W2, AUX	SW4-1=OFF SW4-2=ON SW4-3=OFF	Heat + AUX, AUX	976
		Electric heater kit 3	5KW	SW4-1=OFF SW4-2=ON SW4-3=ON	W1, W2, AUX	SW4-1=OFF SW4-2=ON SW4-3=ON	Heat + AUX, AUX	918

Air volume table

Capacity	External Static Pressure Range	Fan Speed	Electric heater kit	24V thermostat		Wired controller		Airflow volume (CFM)
				DIP Switch	24V terminal engaged	DIP Switch	Mode	
36K (3 Ton)	0 - 0.80 in. w.g.	Cooling Turbo	—	SW3-4=ON	Y2/Y	—	Cool	1188
		Cooling High	—	SW3-4=OFF	Y2/Y	—	Cool	1082
		Cooling Medium	—	—	Y1	—	Cool	971
		Cooling Low	—	—	—	—	Cool	865
		Heat Pump Turbo	—	—	—	—	Heat	1112
		Heat Pump High	—	—	B+Y2/Y, W	—	Heat	1059
		Heat Pump Medium	—	—	Y1	—	Heat	794
		Heat Pump Low	—	—	—	—	Heat	582
		Electric heater kit 0(Default)	20KW	SW4-1=OFF SW4-2=OFF SW4-3=OFF	W1, W2, AUX	SW4-1=OFF SW4-2=OFF SW4-3=OFF	Heat + AUX, AUX	1306
		Electric heater kit 1	15KW	SW4-1=OFF SW4-2=OFF SW4-3=ON	W1, W2, AUX	SW4-1=OFF SW4-2=OFF SW4-3=ON	Heat + AUX, AUX	1241
		Electric heater kit 2	10KW, 8KW	SW4-1=OFF SW4-2=ON SW4-3=OFF	W1, W2, AUX	SW4-1=OFF SW4-2=ON SW4-3=OFF	Heat + AUX, AUX	1176
		Electric heater kit 3	5KW, 8KW	SW4-1=OFF SW4-2=ON SW4-3=ON	W1, W2, AUX	SW4-1=OFF SW4-2=ON SW4-3=ON	Heat + AUX, AUX	1112
48K (4 Ton)	0 - 0.80 in. w.g.	Cooling Turbo	—	SW3-4=ON	Y2/Y	—	Cool	1471
		Cooling High	—	SW3-4=OFF	Y2/Y	—	Cool	1282
		Cooling Medium	—	—	Y1	—	Cool	1094
		Cooling Low	—	—	—	—	Cool	906
		Heat Pump Turbo	—	—	—	—	Heat	1471
		Heat Pump High	—	—	B+Y2/Y, W	—	Heat	1306
		Heat Pump Medium	—	—	Y1	—	Heat	1141
		Heat Pump Low	—	—	—	—	Heat	976
		Electric heater kit 0(Default)	20KW	SW4-1=OFF SW4-2=OFF SW4-3=OFF	W1, W2, AUX	SW4-1=OFF SW4-2=OFF SW4-3=OFF	Heat + AUX, AUX	1741
		Electric heater kit 1	15KW	SW4-1=OFF SW4-2=OFF SW4-3=ON	W1, W2, AUX	SW4-1=OFF SW4-2=OFF SW4-3=ON	Heat + AUX, AUX	1653
		Electric heater kit 2	10KW, 8KW	SW4-1=OFF SW4-2=ON SW4-3=OFF	W1, W2, AUX	SW4-1=OFF SW4-2=ON SW4-3=OFF	Heat + AUX, AUX	1559
		Electric heater kit 3	8KW	SW4-1=OFF SW4-2=ON SW4-3=ON	W1, W2, AUX	SW4-1=OFF SW4-2=ON SW4-3=ON	Heat + AUX, AUX	1471
60K (5 Ton)	0 - 0.80 in. w.g.	Cooling Turbo	—	SW3-4=ON	Y2/Y	—	Cool	1806
		Cooling High	—	SW3-4=OFF	Y2/Y	—	Cool	1582
		Cooling Medium	—	—	Y1	—	Cool	1359
		Cooling Low	—	—	—	—	Cool	1135
		Heat Pump Turbo	—	—	—	—	Heat	1659
		Heat Pump High	—	—	B+Y2/Y, W	—	Heat	1582
		Heat Pump Medium	—	—	Y1	—	Heat	1247
		Heat Pump Low	—	—	—	—	Heat	976
		Electric heater kit 0(Default)	25KW	SW4-1=OFF SW4-2=OFF SW4-3=OFF	W1, W2, AUX	SW4-1=OFF SW4-2=OFF SW4-3=OFF	Heat + AUX, AUX	2171
		Electric heater kit 1	15KW, 20KW	SW4-1=OFF SW4-2=OFF SW4-3=ON	W1, W2, AUX	SW4-1=OFF SW4-2=OFF SW4-3=ON	Heat + AUX, AUX	2029
		Electric heater kit 2	10KW, 15KW	SW4-1=OFF SW4-2=ON SW4-3=OFF	W1, W2, AUX	SW4-1=OFF SW4-2=ON SW4-3=OFF	Heat + AUX, AUX	1894
		Electric heater kit 3	10KW	SW4-1=OFF SW4-2=ON SW4-3=ON	W1, W2, AUX	SW4-1=OFF SW4-2=ON SW4-3=ON	Heat + AUX, AUX	1753

NOTICE

The constant airflow volume motor is applied .So the airflow volume is constant at all ESP within stated range.

SPECIFICATIONS

Cooling and Heating power specifications(for North America models)

MODEL(Btu/h)		18K	24K	30K	
POWER (outdoor)	PHASE	1 Phase			
	FREQUENCY AND VOLT	208/230V,60Hz			
INPUT CIRCUIT FUSE		6.3A 30A	6.3A 30A	6.3A 30A	
LINES GAUGE	OUTDOOR UNIT POWER LINE	LINE QUANTITY	2+Ground		
		LINE DIAMETER(AWG)	14	12	12
	OUTDOOR-INDOOR SIGNAL LINE	LINE QUANTITY	---		
		LINE DIAMETER(AWG)	---		
	THERMOSTAT SIGNAL LINE	LINE QUANTITY	---		
		LINE DIAMETER(AWG)	18		
	INDOOR-OUTDOOR CONNECTION LINE	LINE QUANTITY	4		
		LINE DIAMETER(AWG)	16		

MODEL(Btu/h)		36K	48K	60K	
POWER (outdoor)	PHASE	1 Phase			
	FREQUENCY AND VOLT	208/230V,60Hz			
INPUT CIRCUIT FUSE		16A 60A	16A 60A	16A 60A	
LINES GAUGE	OUTDOOR UNIT POWER LINE	LINE QUANTITY	2+Ground		
		LINE DIAMETER(AWG)	STD 12 HH 8	STD 10 HH 8	STD 10 HH NA
	OUTDOOR-INDOOR SIGNAL LINE	LINE QUANTITY	2		
		LINE DIAMETER(AWG)	20		
	THERMOSTAT SIGNAL LINE	LINE QUANTITY	---		
		LINE DIAMETER(AWG)	18		
	INDOOR-OUTDOOR CONNECTION LINE	LINE QUANTITY	3		
		LINE DIAMETER(AWG)	16		

AIR EVACUATION

NOTICE

When opening valve stems, turn the hexagonal wrench until it hits against the stopper. Do not try to force the valve to open further.

Preparations and precautions

Air and foreign matter in the refrigerant circuit can cause abnormal rises in pressure, which can damage the air conditioner, reduce its efficiency, and cause injury. Use a vacuum pump and manifold gauge to evacuate the refrigerant circuit, removing any non-condensable gas and moisture from the system. Evacuation should be performed upon initial installation and when unit is relocated.

BEFORE PERFORMING EVACUATION

- ✓ Check to make sure the connective pipes between the indoor and outdoor units are connected properly.
- ✓ Check to make sure all wiring is connected properly.

Evacuation Instructions

1. Connect the charge hose of the manifold gauge to service port on the outdoor unit's low pressure valve.
2. Connect another charge hose from the manifold gauge to the vacuum pump.
3. Open the Low Pressure side of the manifold gauge. Keep the High Pressure side closed.
4. Turn on the vacuum pump to evacuate the system.
5. Run the vacuum for at least 15 minutes, or until the Compound Meter reads $-750 \text{ Micron HG} (-10^5 \text{ Pa})$.

Outdoor unit

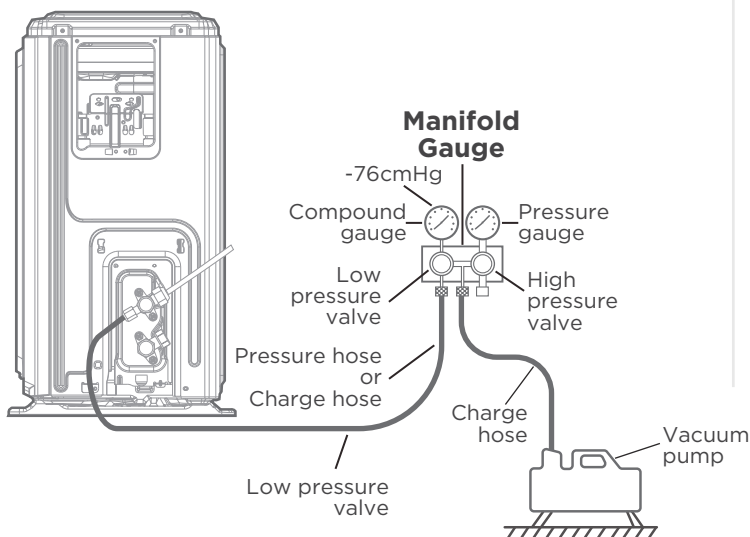

6. Close the Low Pressure side of the manifold gauge, and turn off the vacuum pump.
7. Wait for 5 minutes, then check that there has been no change in system pressure.
8. If there is a change in system pressure, refer to Gas Leak Check section for information on how to check for leaks. If there is no change in system pressure, unscrew the cap from the packed valve (high pressure valve).
9. Insert hexagonal wrench into the packed valve (high pressure valve) and open the valve by turning the wrench in a 1/4 counterclockwise turn. Listen for gas to exit the system, then close the valve after 5 seconds.
10. Watch the Pressure Gauge for one minute to make sure that there is no change in pressure. The Pressure Gauge should read slightly higher than atmospheric pressure.
11. Remove the charge hose from the service port.

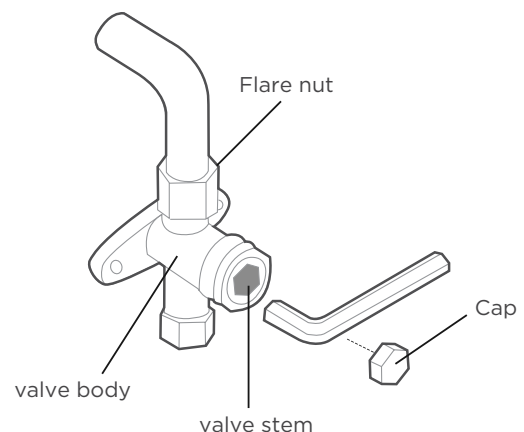

12. Using hexagonal wrench, fully open both the high pressure and low pressure valves.
13. Tighten valve caps on all three valves (service port, high pressure, low pressure) by hand. You may tighten it further using a torque wrench if needed.

NOTE ON ADDING REFRIGERANT

CAUTION

DO NOT mix refrigerant types.

Some systems require additional charging depending on pipe lengths. The standard pipe length varies according to local regulations. For example, in North America, the standard pipe length is 7.5m (25'). In other areas, the standard pipe length is 5m (16'). The refrigerant should be charged from the service port on the outdoor unit's low pressure valve. The additional refrigerant to be charged can be calculated using the following formula:

	Liquid Side Diameter		
	φ6.35(1/4")	φ9.52(3/8")	φ12.7(1/2")
R410A: (metering device in the indoor unit)	(Total pipe length - standard pipe length) x30g(0.32oz)/m(ft)	(Total pipe length - standard pipe length) x65g(0.69oz)/m(ft)	(Total pipe length - standard pipe length) x115g(1.23oz)/m(ft)
R410A: (metering device in the outdoor unit)	(Total pipe length - standard pipe length) x15g(0.16oz)/m(ft)	(Total pipe length - standard pipe length) x30g(0.32oz)/m(ft)	(Total pipe length - standard pipe length) x65g(0.69oz)/m(ft)
R32 :	(Total pipe length - standard pipe length)x 12g(0.13oz)/m(ft)	(Total pipe length - standard pipe length)x 24g(0.26oz)/m(ft)	(Total pipe length - standard pipe length)x 40g(0.42oz)/m(ft)

TEST RUN

CAUTION

Failure to perform the test run may result in unit damage, property damage, or personal injury.

Before test run

A test run must be performed after the entire system has been completely installed. Confirm the following points before performing the test:

- a) Indoor and outdoor units are properly installed.
- b) Piping and wiring are properly connected.
- c) No obstacles near the inlet and outlet of the unit that might cause poor performance or product malfunction.
- d) Refrigeration system does not leak.
- e) Drainage system is unimpeded and draining to a safe location.
- f) Insulation of piping and duct is properly installed.
- g) Grounding wires are properly connected.
- h) Length of the piping and additional refrigerant capacity have been recorded.
- i) Power voltage is the correct voltage for the air conditioner

Test run instructions

1. Open both the liquid and gas service valves.
2. Turn on the main power switch and allow the unit to warm up.
3. Set the air conditioner to COOL mode.
4. For the Indoor Unit
 - a. Double check to see if the room temperature is being registered correctly.
 - b. Ensure the manual buttons on the indoor unit works properly.
 - c. Check to see that the drainage system is unimpeded and draining smoothly.
 - d. Ensure there is no vibration or abnormal noise during operation.

5. For the Outdoor Unit
 - a. Check to see if the refrigeration system is leaking.
 - b. Make sure there is no vibration or abnormal noise during operation.
 - c. Ensure the wind, noise, and water generated by the unit do not disturb your neighbors or pose a safety hazard.
6. Drainage Test
 - a. Ensure the drainpipe flows smoothly. New buildings should perform this test before finishing the ceiling.
 - b. Turn on the main power switch and run the air conditioner in COOL mode.
 - c. Check to see that the water is discharged. It may take up to one minute before the unit begins to drain depending on the drainpipe.
 - d. Make sure that there are no leaks in any of the piping.
 - e. Stop the air conditioner. Turn off the main power switch and reinstall the test cover.

NOTICE

If the unit malfunctions or does not operate according to your expectations, please refer to the Troubleshooting section of Service Manual before calling customer service.

The design and specifications are subject to change without prior notice for product improvement. Consult with the sales agency or manufacturer for details. Any updates to the manual will be uploaded to the service website, please check for the latest version.

24V SIGNAL CHART

Mode	Priority	24V input terminal									Fan speed	Display
		G	Y1	Y/Y2	B	W	W1	W2	E/AUX	DH/DS/BK		
OFF	/	0	0	0	0	0	0	0	0	*	OFF	0
FAN	7	1	0	0	*	0	0	0	0	*	Low	1
Cooling stage 1	6	*	1	0	0	0	0	0	0	1	Mid	2
Cooling stage 2		*	*	1	0	0	0	0	0	1	High	3
Dehumidification		*	1	0	0	0	0	0	0	0	Low	4
Dehumidification		*	*	1	0	0	0	0	0	0	Low	5
Heat pump stage 1	5	*	1	0	1	0	0	0	0	1	Mid	7
Heat pump stage 2		*	*	1	1	0	0	0	0	1	High	
Heat pump stage 2		*	*	*	*	1	0	0	0	1	High	
Electric heater kit 1	3	*	0	0	*	0	1	0	0	*	Turbo	8
Electric heater kit 2		*	0	0	*	0	0	1	0	*	Turbo	
Electric heater kit 1 and kit 2		*	0	0	*	0	1	1	0	*	Turbo	
Heat pump stage 1 + Electric heater kit 1	4	*	1	0	1	0	1	0	0	1	Turbo	10
Heat pump stage 1 + Electric heater kit 2		*	1	0	1	0	0	1	0	1	Turbo	
Heat pump stage 2 + Electric heater kit 1		*	*	1	1	0	1	0	0	1	Turbo	
Heat pump stage 2 + Electric heater kit 1		*	*	*	*	1	1	0	0	1	Turbo	
Heat pump stage 2 + Electric heater kit 2		*	*	1	1	0	0	1	0	1	Turbo	
Heat pump stage 2 + Electric heater kit 2		*	*	*	*	1	0	1	0	1	Turbo	
Heat pump stage 1 + Electric heater kit 1 and kit 2		*	1	0	1	0	1	1	0	1	Turbo	
Heat pump stage 2 + Electric heater kit 1 and kit 2		*	*	1	1	0	1	1	0	1	Turbo	
Heat pump stage 2 + Electric heater kit 1 and kit 2		*	*	*	*	1	1	1	0	1	Turbo	
Heat pump stage 2 + Electric heater kit 1 and kit 2		*	*	*	*	1	1	1	0	1	Turbo	
Emergency heat	1	*	*	*	*	*	*	*	1	*	Turbo	12
Heating zone control	2	*	1	0	1	0	*	*	0	0	Low	13
Heating zone control		*	*	1	1	0	*	*	0	0	Low	
Heating zone control		*	*	*	*	1	*	*	0	0	Low	
Heating zone control		*	0	0	*	0	1	0	0	0	Low	
Heating zone control		*	0	0	*	0	0	1	0	0	Low	
Heating zone control		*	0	0	*	0	1	1	0	0	Low	

Note:

1: 24V signal

0: No 24V signal

*: 1 or 0.

The AHU will turn off if the 24V input cannot meet the table.

Matching With Multi Zone Outdoor Unit

When matching with multi zone outdoor unit, the indoor unit cannot be started due to the mode conflict in the following cases.

Mode Of AHU	Mode Of other IDU zones	Mode Conflict Unit
Fan	Heating/ Electric heat/ Emergency heat	AHU
Cooling		AHU
Dehumidification		AHU
Heating	Fan/Cooling/Dehumidification	Other IDU zones
Electric heat		Other IDU zones
Emergency heat		Other IDU zones

Note:

● When Heating reaches the temperature and shuts down with other IDU zones heating normally, the AHU fan will stop running, and the Fan-ON mode is invalid.

● The heat pump will start synchronously when Emergency heat or Electric heat is started.

● When two AHU units are connected by multi zone outdoor unit, the above rules are applicable while one of the AHU unit regarded as other IDU zones.



AlpineHomeAir.com

16123100A07153