

R454b Refrigerant

SUBMITTAL DATA SHEET

Air Handler Heat Pump System

Location:	Approval:
Engineer:	Date:
Submitted to:	Construction:
Submitted by:	Unit #:
Reference:	Drawing #:



INDOOR SPECIFICATION

Dimension (WxDxH)	inch	24-1/2 x 21 x 28
	mm	622 x 533 x 711
Package (WxDxH)	inch	27-3/4 x 26-1/8 x 30-3/8
	mm	705 x 665 x 770
Net/Gross Weight	lbs	81 / 92
	kg	36.8 / 41.9

OUTDOOR SPECIFICATION

Compressor Type	ROTARY	
Compressor Model	MTH550UKPC8FU	
Refrigerant	R454B	
Refrigerant Oil Charge(mL)	1,800	
Refrigerant Oil	HAF68D1C	
Outdoor Air Flow (Max) (CFM)	3,037	
Outdoor Noise Level (dBA)	65	
Dimension (WxDxH)	inch	38-9/16 x 16-3/8 x 38-3/8
	mm	980 x 415 x 975
Package (WxDxH)	inch	45-1/16 x 19-11/16 x 42-1/2
	mm	1145 x 500 x 1080
Net/Gross Weight	lbs	193 / 224
	kg	87.5 / 101.7

EFFICIENCY

Cooling		Heating	
SEER2	14.8	HSPF2-4	8.0
EER2	9.8	COP	2.75

PERFORMANCE of Cooling

Cooling (Btu/hr)	
Rated Capacity	45,000
Min/Max Capacity	15,500~47,000
Moisture Removal(L/h)	4
Standard Operating Range(°F/°C)	-13~122 (-25~50)
Rated Cooling Conditions:	Indoor: 80°F DB/67°F WB Outdoor: 95°F DB/75°F WB

PERFORMANCE of Heating

Heating (Btu/hr)	
1. @ 47°F Rated	47,000
2. @ 47°F Min/Max Capacity	10,600~47,000
3. @ 17°F Rated	28,000
4. @ 5°F Rated: Capacity / COP	42,000/1.85
5. @ 5°F Max: Capacity	40,000
Standard Operating Range(°F/°C)	-13~75 (-25~24)
1. Rated Heating Conditions:	Indoor: 70°F DB/60°F WB Outdoor: 47°F DB/43°F WB
2. Rated Heating Conditions:	Indoor: 70°F DB/60°F WB Outdoor: 17°F DB/15°F WB
3. Heating Conditions, Compressor Operating at Max. Frequency	Indoor: 70°F DB/60°F WB Outdoor: 5°F DB/5°F WB

ELECTRICAL

Indoor Power Supply	24V,60Hz,1Ph	
Indoor MCA 115V/(208/230V)	/	
Indoor MOP	/	
Outdoor Power Supply	208/230,60Hz,1Ph	
Outdoor MCA	36.0	
Outdoor MOP	40.0	
Communication Wiring	AWG 20-2	
Compressor RLA	27	
Outdoor Fan Motor RLA	2	
Outdoor Fan Motor W	250	
Indoor Fan Motor RLA	/	
Indoor Fan Motor W	/	
System Power Input @ Cooling (W)	4,736 (1,430~5,050)	
System Power Input @ Heating (W)	4,910 (1,400~5,010)	
MCA: Min. circuit amps (A)	MOCP: Max. over current protection (A)	
RLA: Rated load amps (A)	W: Fan motor rated output (W)	

PIPING

Throttle type(Indoor)	EXV
Throttle type(Outdoor)	EXV
Liquid Size	3/8" (9.52mm)
Gas Size	3/4" (19mm)
Max. Piping Length(ft/m)	246 (75)
Max. Height Difference(ft/m)	98.4 (30)
Max. Pre-charged Length(ft/m)	25 (7.5)
Refrigerant Pre-charged Amount (oz/ft)(g/m)	134 (3.8)
Additional Charge of Refrigerant((oz/ft)/(g/m)	0.7 (65)
Connection Method	Flared

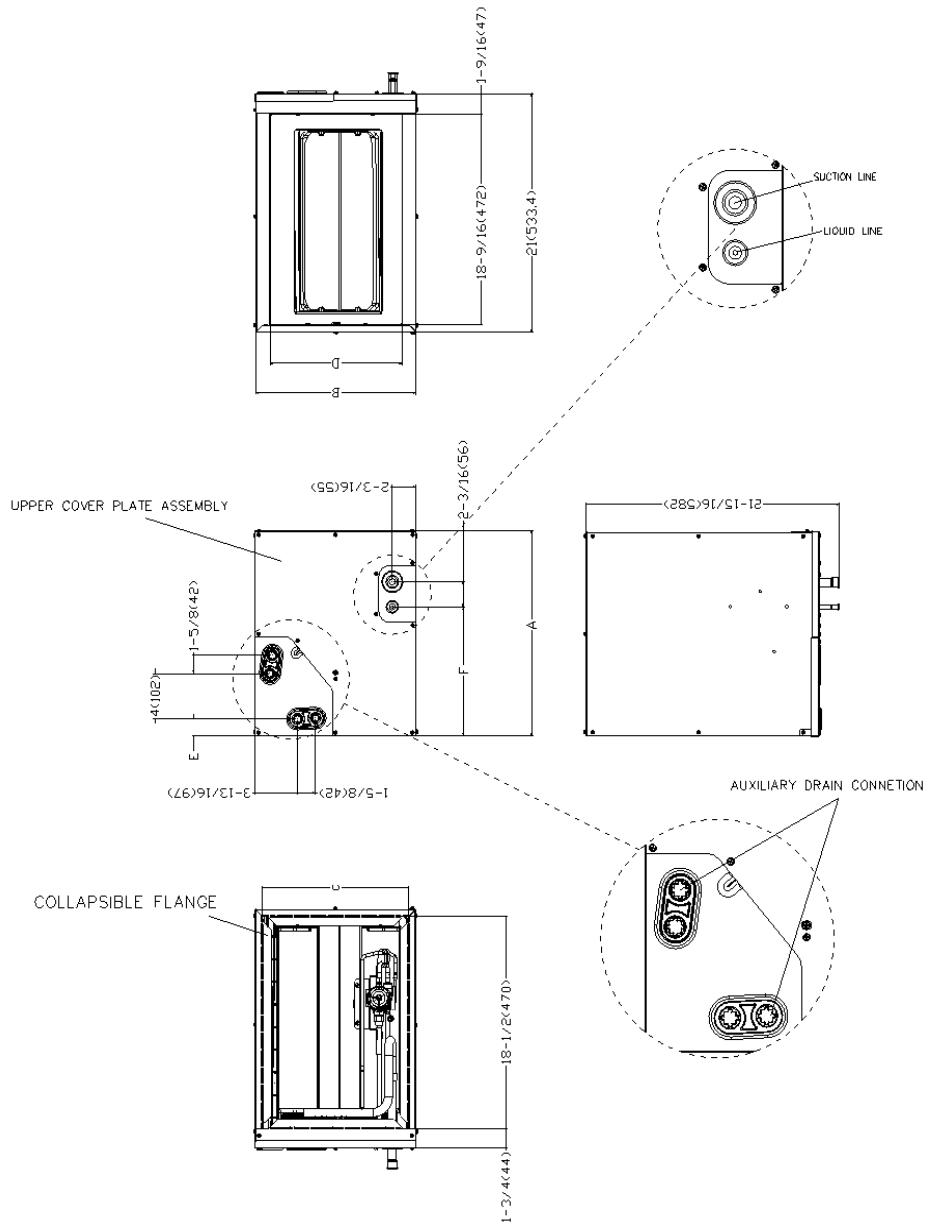

Model		60-D	
Dimensions		inch	mm
A	Model Height	28	711
B	Model Width	24-1/2	622
C	Supply Air Opening Width	23-1/4	591
D	Return Air Opening Width	23-1/8	587
E	Condensate Drains Height	2-3/16	55
F	Liquid Line Height	21-7/16	545

Outdoor Unit Dimension

Unit:inch(mm)

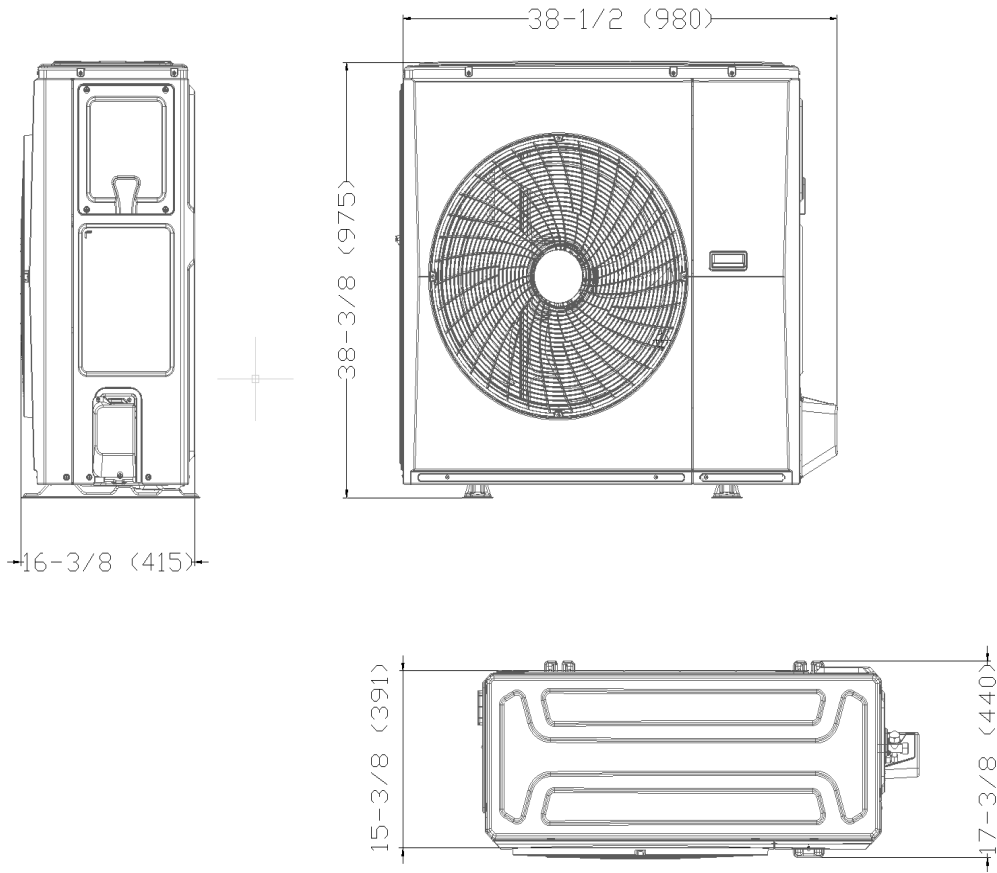

Installation Instruction For Outdoor Unit

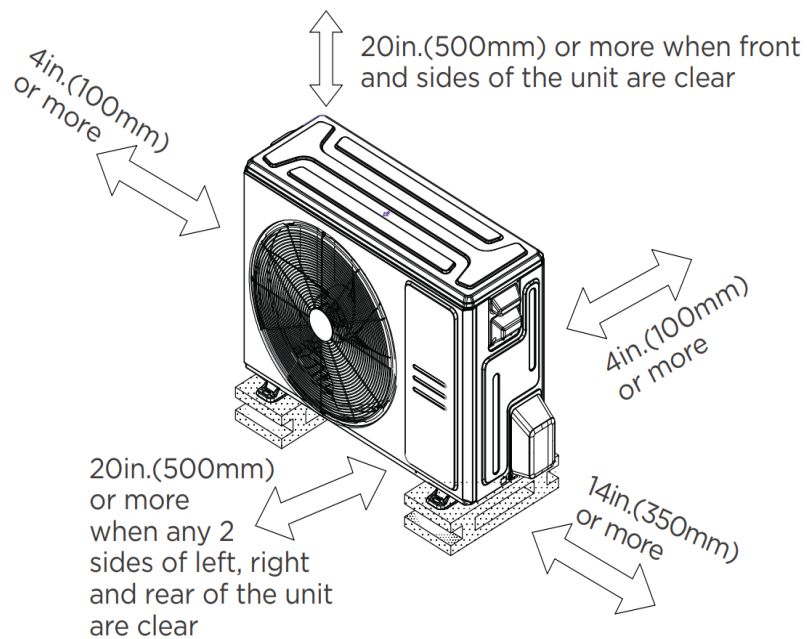

Features

- Multi-position installation: horizontal(left or right), vertical(up or down)
- Aluminum Coil
- R454B refrigerant sensor
- Easy Maintenance
- Multiple control options available:
 - Two way communication wired controller with built-in WiFi:120N(X6W)
 - Third-Party 24V Thermostat