

SUBMITTAL DATA SHEET

Slim Duct Regular System	
Location:	Approval:
Engineer:	Date:
Submitted to:	Construction:
Submitted by:	Unit #:
Reference:	Drawing #:



INDOOR SPECIFICATION	
Indoor Air Flow (Turbo/H/M/L/S) (CFM)	1236.1 / 1059.5 / 941.8 / 765.2 / N/A
Indoor Noise Level (Turbo/H/M/L/S) (dBA)	N/A/45/39.5/33/30
Indoor static pressure range(in.w.g.)	0-0.8
Dimension (W×D×H)	inch 47.24 x 29.53 x 11.81
	mm 1200.0×750.0×300.0
Package (W×D×H)	inch 56.10 x 33.86 x 14.13
	mm 1425×860×359
Net/Gross Weight	lbs 106.26/120.37
	kg 48.2/54.6

OUTDOOR SPECIFICATION	
Compressor Type	ROTARY
Compressor Model	KTF310D43UMT
Refrigerant	R454B
Refrigerant Oil Charge(mL)	1000
Refrigerant Oil	5.4
Outdoor Air Flow (Max) (CFM)	2413.3
Outdoor Noise Level (dBA)	63.0
Dimension (W×D×H)	inch 37.24 x 16.14 x 31.89
	mm 946.0×410.0×810.0
Package (W×D×H)	inch 42.91 x 19.68 x 34.84
	mm 1090×500×885
Net/Gross Weight	lbs 152.34/162.48
	kg 69.1/73.7

EFFICIENCY			
Cooling		Heating	
SEER2	18.7	HSPF2-4	10.2
EER2	10.1	COP	3.70

PERFORMANCE of Cooling	
Cooling (Btu/hr)	
Rated Capacity	36000
Min/Max Capacity	7900~42500
Moisture Removal(L/h)	3.65
Standard Operating Range(°F/°C)	-13~122(-25~50)
Conditions:	Indoor: 80°F DB/67°F WB Outdoor: 95°F DB/75°F WB

PERFORMANCE of Heating	
Heating (Btu/hr)	
1. @ 47°F Rated	40000
1. @ 47°F Min/Max Capacity	8100~43500
2. @ 17°F Rated	27400
3. @ 5°F Rated: Capacity / COP	25600/2.10
3. @ 5°F Max: Capacity	25600
Standard Operating Range(°F/°C)	-13~75(-25~24)
1. Conditions:	Indoor: 70°F DB/60°F WB Outdoor: 47°F DB/43°F WB
2. Conditions:	Indoor: 70°F DB/60°F WB Outdoor: 17°F DB/15°F WB
3. Conditions:	Indoor: 70°F DB/60°F WB Outdoor: 5°F DB/5°F WB

ELECTRICAL	
Power Supply	208/230V,60Hz,1Ph
System MCA	33.00
Connection Wiring	14#x3
System MOCP	35
Compressor RLA	21.5
Outdoor Fan Motor RLA	1.4
Outdoor Fan Motor W	120
Indoor Fan Motor RLA	3.2
Indoor Fan Motor W	400
System Power Input @ Cooling (W)	3530(660 ~ 4250)
System Power Input @ Heating (W)	3170(520 ~ 3360)
MCA: Min. circuit amps (A)	MOCP: Max. over current protection (A)
RLA: Rated load amps (A)	W: Fan motor rated output (W)

PIPING	
Throttle type(Indoor)	N/A
Throttle type(Outdoor)	EXV+Throttle valve
Liquid Size	9.52mm(3/8in)
Gas Size	19mm(3/4in)
Max. Piping Length(ft/m)	246.00(75)
Max. Height Difference(ft/m)	98.40(30)
Max. Pre-charged Length(ft/m)	24.6(7.5)
Refrigerant Pre-charged Amount	91.7(2.60)
Additional Charge of Refrigerant(oz/ft)(g/m)	0.32(30)
Connection Method	Flared

Indoor Unit Dimension

MODEL	A	B	C	D
9K	27-1/2in(700mm)	7-7/8in(200mm)	17-3/4(450mm)	20in(506mm)
12K	27-1/2in(700mm)	9-5/8in(245mm)	29-1/2(750mm)	31-1/4in(795mm)
18K~24K	39-3/8in(1000mm)	9-5/8in(245mm)	29-1/2(750mm)	31-1/4in(795mm)
36K~48K	47-1/8in(1200mm)	11-7/8in(300mm)	29-1/2(750mm)	31-1/4in(795mm)
60K	55-1/8in(1400mm)	15in(380mm)	31-1/2in(800mm)	33-1/4in(845mm)

Installation Instruction

Outdoor Unit Dimension

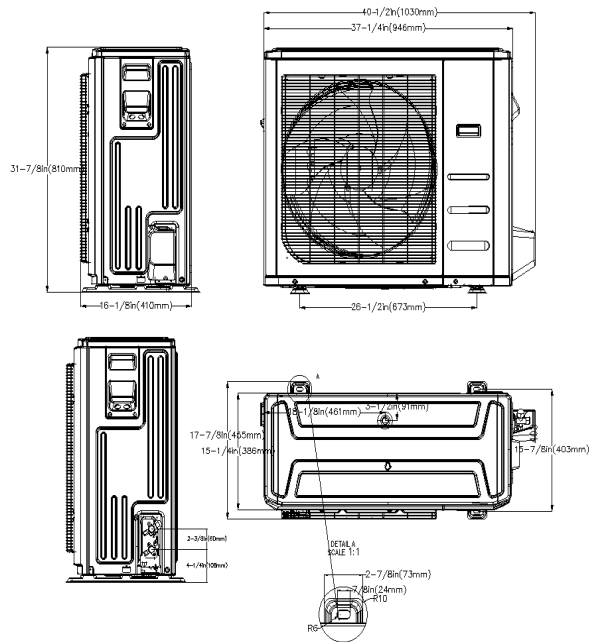

Installation Instruction

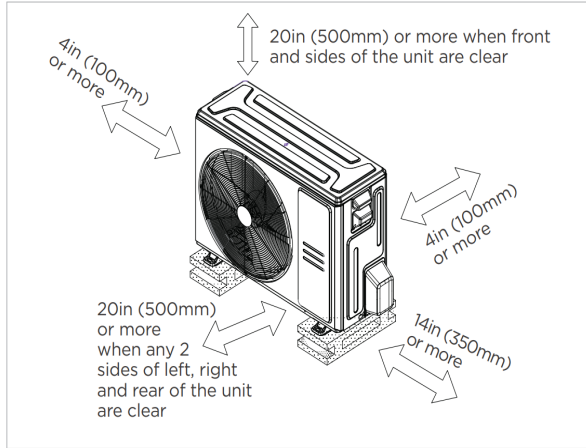

Meets all spatial requirements shown in Installation Clearance Requirements above.

Fan performance

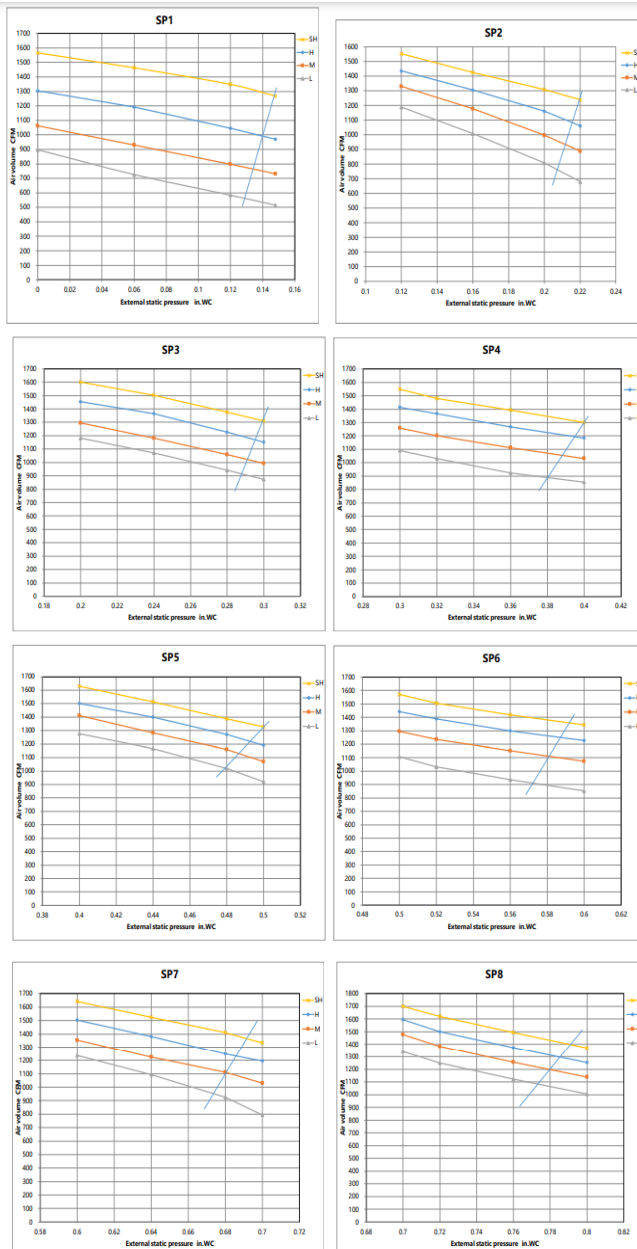

Constant air volume

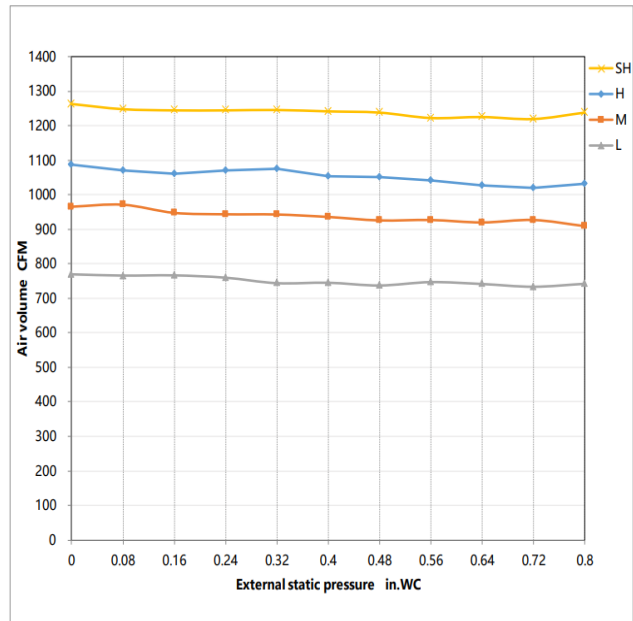

FEATURES

- Compatible with both horizontal and vertical installation
- Static pressure up to 0.8 in.w.g(for all models)
- Static pressure setting stages: 8
- Refrigerant leakage detection sensor
- Constant airflow
- Built-in pump
- i-clean
- Fan speed stages: 1~100%
- WiFi capability: through wired controller with built-in WiFi
- OTA(by using wired controller 120N(X6W))
- 2-pin connector(HA/HB) for programmable wired controller
- Multiple control options available:
 - Two way communication wired controller:120N(X6)
 - Two way communication wired controller with built-in WiFi:120N(X6W)
 - Infrared wired controller: 120L
 - Wireless remote controller
 - Third-Party 24V Thermostat*

*24V interface is required.