

SUBMITTAL DATA SHEET

Ceiling&Floor Regular System BXALA36FC0-BXL1A36SC0

Location:	Approval:
Engineer:	Date:
Submitted to:	Construction:
Submitted by:	Unit #:
Reference:	Drawing #:



INDOOR SPECIFICATION

Indoor Air Flow (Turbo/H/M/L/Si) (CFM)	1224.3 / 1088.9 / 988.8 / 765.2 / 653.3	
Indoor Noise Level (Turbo/H/M/L/Si) (dBA)	N/A/49.5/44.5/37.0/33.0	
Dimension (W×D×H)	inch	64.96 x 26.57 x 9.25
	mm	1650.0×675.0×235.0
Package (W×D×H)	inch	67.91 x 29.72 x 12.52
	mm	1725×755×318
Net/Gross Weight	lbs	88.85/104.94
	kg	40.3/47.6

OUTDOOR SPECIFICATION

Compressor Type	ROTARY	
Compressor Model	KTF310D43UMT	
Refrigerant	R454B	
Refrigerant Oil Charge(mL)	1000	
Refrigerant Oil	VG74	
Outdoor Air Flow (Max) (CFM)	2413.3	
Outdoor Noise Level (dBA)	64.0	
Dimension (W×D×H)	inch	37.24 x 16.14 x 31.89
	mm	946.0×410.0×810.0
Package (W×D×H)	inch	42.91 x 19.68 x 34.84
	mm	1090×500×885
Net/Gross Weight	lbs	152.34/162.48
	kg	69.1/73.7

EFFICIENCY

Cooling		Heating	
SEER2	20.0	HSPF2-4	10.0
EER2	10.1	COP	3.34

PERFORMANCE of Cooling

Cooling (Btu/hr)	
Rated Capacity	36000
Min/Max Capacity	7300~39500
Moisture Removal(L/h)	3.23
Standard Operating Range(°F/°C)	-13~122(-25~50)
Conditions:	Indoor: 80°F DB/67°F WB Outdoor: 95°F DB/75°F WB

PERFORMANCE of Heating

Heating (Btu/hr)	
1. @ 47°F Rated	38000
1. @ 47°F Min/Max Capacity	14100~40400
2. @ 17°F Rated	26400
3. @ 5°F Rated: Capacity / COP	26000/2.17
3. @ 5°F Max: Capacity	26000
Standard Operating Range(°F/°C)	-13~75(-25~24)
1. Conditions:	Indoor: 70°F DB/60°F WB Outdoor: 47°F DB/43°F WB
2. Conditions:	Indoor: 70°F DB/60°F WB Outdoor: 17°F DB/15°F WB
3. Conditions:	Indoor: 70°F DB/60°F WB Outdoor: 5°F DB/5°F WB

ELECTRICAL

Power Supply	208/230V,60Hz,1Ph	
System MCA	33.00	
Connection Wiring	14#x3	
System MOCP	35	
Compressor RLA	21.5	
Outdoor Fan Motor RLA	1.4	
Outdoor Fan Motor W	120	
Indoor Fan Motor RLA	1.0	
Indoor Fan Motor W	90	
System Power Input @ Cooling (W)	3529(560 ~ 4180)	
System Power Input @ Heating (W)	3334(855 ~ 3500)	
MCA: Min. circuit amps (A)	MOCP: Max. over current protection (A)	
RLA: Rated load amps (A)	W: Fan motor rated output (W)	

PIPING

Throttle type(Indoor)	N/A	
Throttle type(Outdoor)	EXV+Throttle valve	
Liquid Size	9.52mm(3/8in)	
Gas Size	19mm(3/4in)	
Max. Piping Length(ft/m)	246.00(75)	
Max. Height Difference(ft/m)	98.40(30)	
Max. Pre-charged Length(ft/m)	24.6(7.5)	
Refrigerant Pre-charged Amount(oz/kg)	91.71(2.60)	
Additional Charge of Refrigerant((oz/ft)/(g/m))	0.32(30)	
Connection Method	Flared	

Indoor Unit Dimension

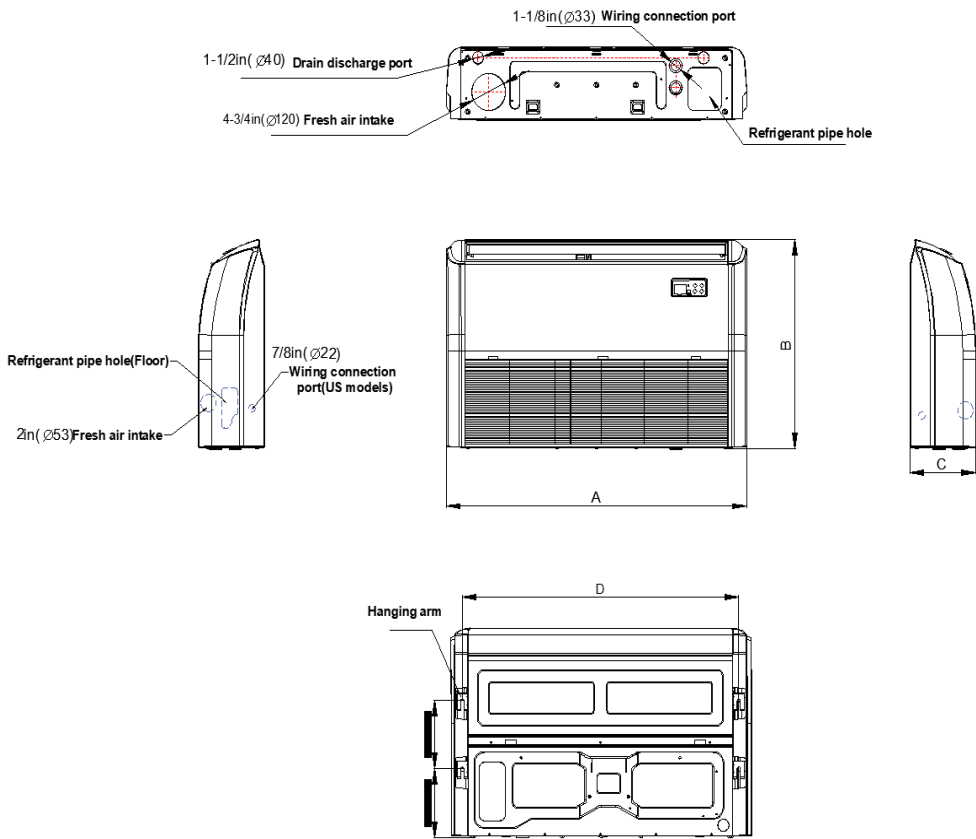

Model	A	B	C	D
18K/24K	42in(1068mm)	26-1/2in(675mm)	9-1/4in(235mm)	38-3/4in(983mm)
36K/48K/60K	65in(1650mm)	26-1/2in(675mm)	9-1/4in(235mm)	61-5/8in(1565mm)

Installation Instruction

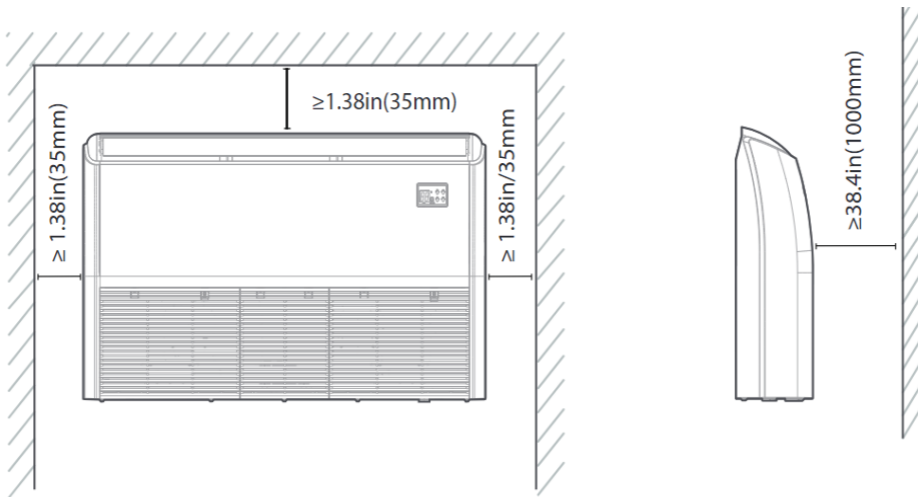

Outdoor Unit Dimension

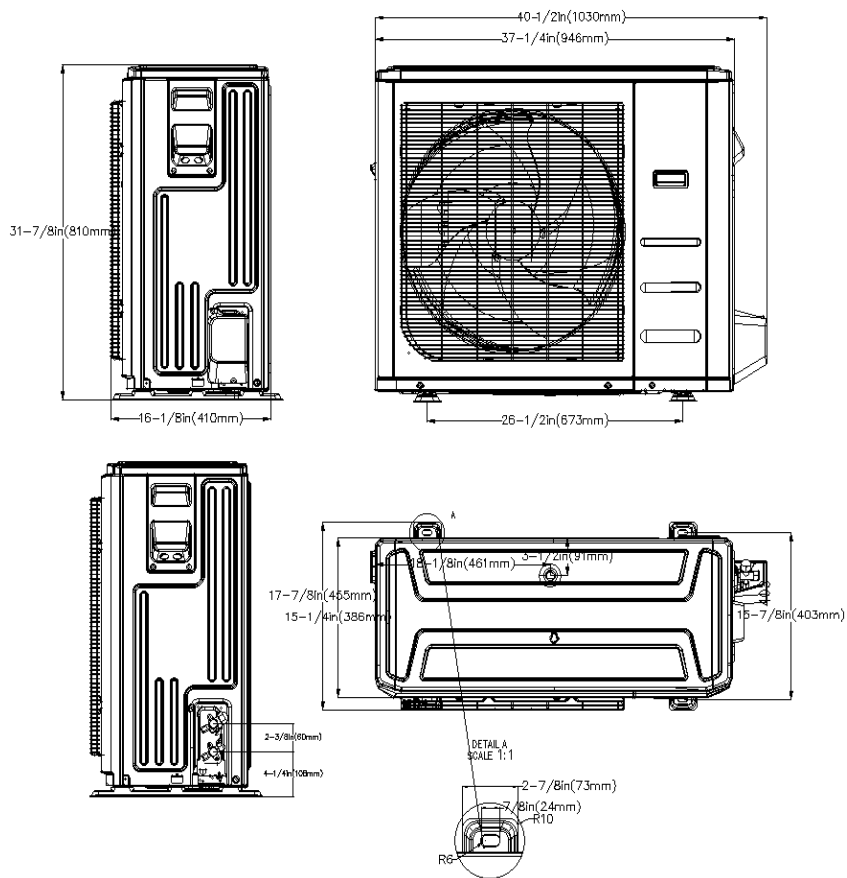

Installation Instruction

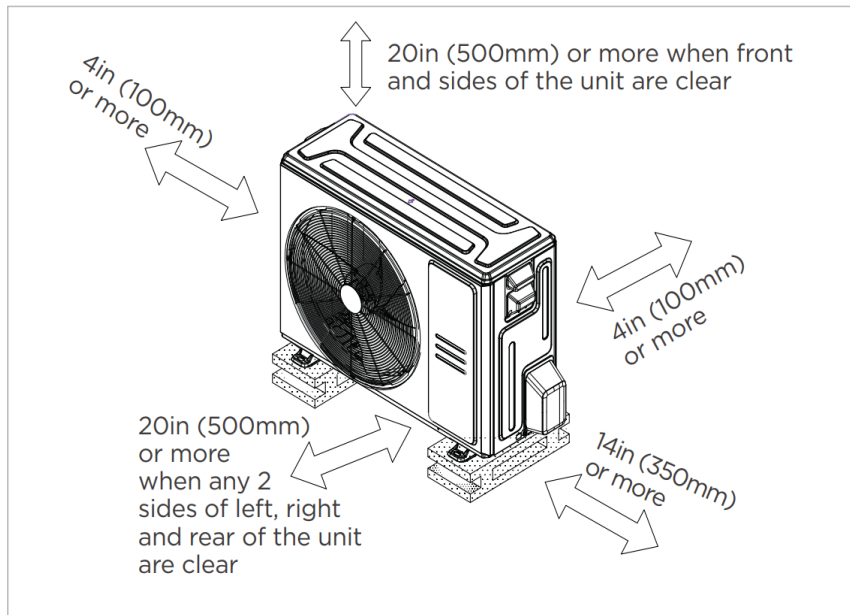

Meets all spatial requirements shown in Installation Clearance Requirements above.

FEATURES

- 2 Style Installation
- 3D Airflow
- Refrigerant leakage detection sensor
- Humidity sensor
- "88" display tube
- 1~100% fan speed setting
- WiFi capability: through WiFi dongle or wired controller with built-in WiFi
- OTA(by using WiFi dongle)
- 2-pin connector(HA/HB) for programmable wired controller
- Multiple control options available:
 - Two way communication wired controller:120N(X6)
 - Two way communication wired controller with built-in WiFi:120N(X6W)
 - Infrared wired controller: 120L
 - Wireless remote controller
 - Third-Party 24V Thermostat*

*24V interface is required.