

# SUBMITTAL DATA SHEET

Ceiling&Floor Regular System BXALA48FC0-BXL1A48SC0	
Location:	Approval:
Engineer:	Date:
Submitted to:	Construction:
Submitted by:	Unit #:
Reference:	Drawing #:



INDOOR SPECIFICATION		
Indoor Air Flow (Turbo/H/M/L/Si) (CFM)	1353.8 / 1236.1 / 1083.0 / 800.5 / 665.1	
Indoor Noise Level (Turbo/H/M/L/Si) (dBA)	N/A/53.0/49.0/39.0/34.5	
Dimension (W×D×H)	inch	64.96 x 26.57 x 9.25
	mm	1650.0×675.0×235.0
Package (W×D×H)	inch	67.91 x 29.72 x 12.52
	mm	1725×755×318
Net/Gross Weight	lbs	89.07/105.16
	kg	40.4/47.7

OUTDOOR SPECIFICATION		
Compressor Type	ROTARY	
Compressor Model	KTQ420D1UMU	
Refrigerant	R454B	
Refrigerant Oil Charge(mL)	1400	
Refrigerant Oil	VG74	
Outdoor Air Flow (Max) (CFM)	4237.9	
Outdoor Noise Level (dBA)	62.5	
Dimension (W×D×H)	inch	37.48 x 16.34 x 52.48
	mm	952.0×415.0×1333.0
Package (W×D×H)	inch	43.11 x 19.49 x 57.48
	mm	1095×495×1460
Net/Gross Weight	lbs	208.78/239.86
	kg	94.7/108.8

EFFICIENCY			
Cooling		Heating	
SEER2	19.8	HSPF2-4	10.2
EER2	9.5	COP	2.82

PERFORMANCE of Cooling	
Cooling (Btu/hr)	
Rated Capacity	48000
Min/Max Capacity	10100~50000
Moisture Removal(L/h)	5.95
Standard Operating Range(°F/°C)	-13~122(-25~50)
Conditions:	Indoor: 80°F DB/67°F WB Outdoor: 95°F DB/75°F WB

PERFORMANCE of Heating	
Heating (Btu/hr)	
1. @ 47°F Rated	50000
1. @ 47°F Min/Max Capacity	15800~59100
2. @ 17°F Rated	39500
3. @ 5°F Rated: Capacity / COP	38500/1.95
3. @ 5°F Max: Capacity	38500
Standard Operating Range(°F/°C)	-13~75(-25~24)
1. Conditions:	Indoor: 70°F DB/60°F WB Outdoor: 47°F DB/43°F WB
2. Conditions:	Indoor: 70°F DB/60°F WB Outdoor: 17°F DB/15°F WB
3. Conditions	Indoor: 70°F DB/60°F WB Outdoor: 5°F DB/5°F WB

ELECTRICAL	
Power Supply	208/230V,60Hz,1Ph
System MCA	39.00
Connection Wiring	14#x3
System MOCP	40
Compressor RLA	24.0
Outdoor Fan Motor RLA	1.2
Outdoor Fan Motor W	85
Indoor Fan Motor RLA	1.0
Indoor Fan Motor W	90
System Power Input @ Cooling (W)	5053(830 ~ 5280)
System Power Input @ Heating (W)	5196(575 ~5860)
MCA: Min. circuit amps (A)	MOCP: Max. over current protection (A)
RLA: Rated load amps (A)	W: Fan motor rated output (W)

PIPING	
Throttle type(Indoor)	N/A
Throttle type(Outdoor)	EXV+Throttle valve
Liquid Size	9.52mm(3/8in)
Gas Size	19mm(3/4in)
Max. Piping Length(ft/m)	246.00(75)
Max. Height Difference(ft/m)	98.40(30)
Max. Pre-charged Length(ft/m)	24.6(7.5)
Refrigerant Pre-charged Amount(oz/kg)	126.99(3.60)
Additional Charge of Refrigerant((oz/ft)/(g/m))	0.32(30)
Connection Method	Flared

Indoor Unit Dimension

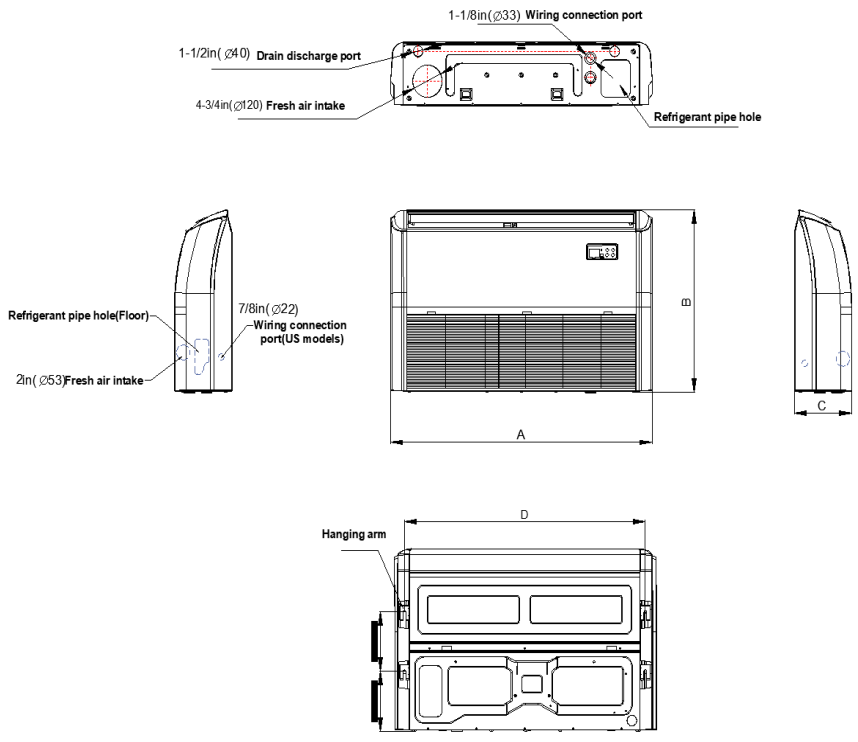

Model	A	B	C	D
18K/24K	42in(1068mm)	26-1/2in(675mm)	9-1/4in(235mm)	38-3/4in(983mm)
36K/48K/60K	65in(1650mm)	26-1/2in(675mm)	9-1/4in(235mm)	61-5/8in(1565mm)

Installation Instruction

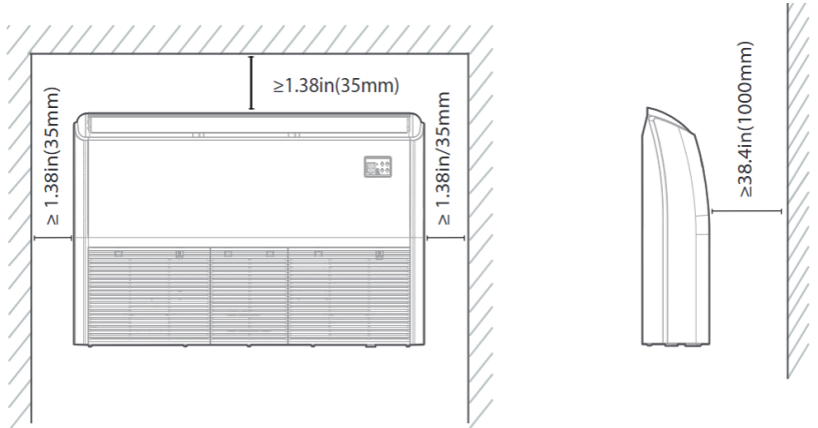

### Outdoor Unit Dimension

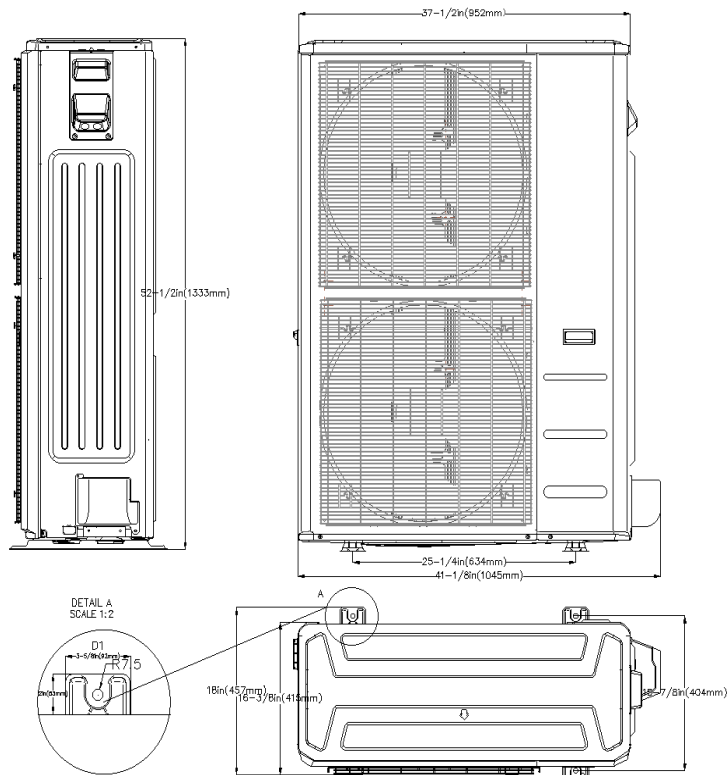

### Installation Instruction

#### REQUIRED CLEARANCE

\*1 20in. (500mm) or more when front and sides of the unit are clear

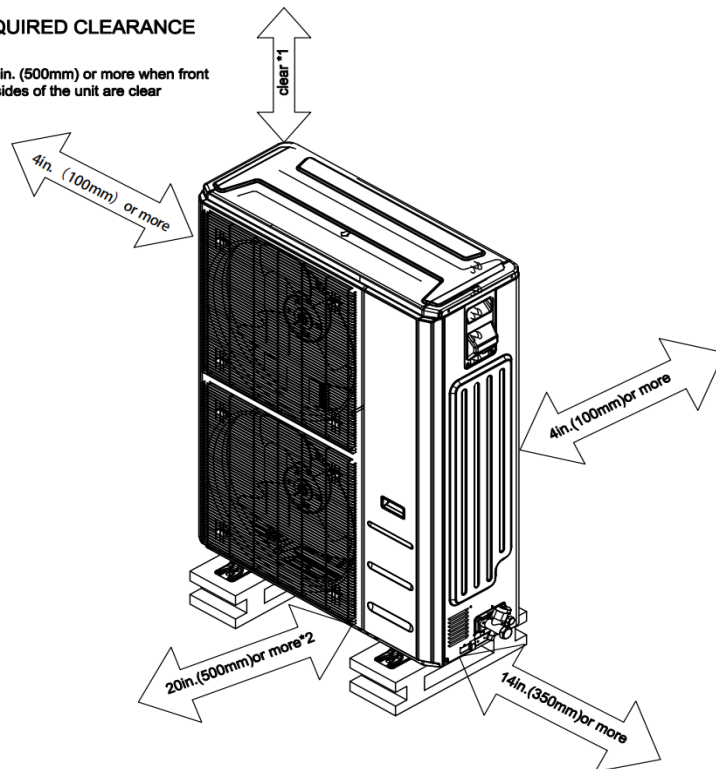

\*2 When any 2 sides of left, right and rear of the unit are clear

## FEATURES

- 2 Style Installation
- 3D Airflow
- Refrigerant leakage detection sensor
- Humidity sensor
- “88” display tube
- 1~100% fan speed setting
- WiFi capability: through WiFi dongle or wired controller with built-in WiFi
- OTA(by using WiFi dongle)
- 2-pin connector(HA/HB) for programmable wired controller
- Multiple control options available:
  - Two way communication wired controller:120N(X6)
  - Two way communication wired controller with built-in WiFi:120N(X6W)
  - Infrared wired controller: 120L
  - Wireless remote controller
  - Third-Party 24V Thermostat\*

\*24V interface is required.