

SUBMITTAL DATA SHEET

High Wall Heat Pump System

Location:	Approval:
Engineer:	Date:
Submitted to:	Construction:
Submitted by:	Unit #:
Reference:	Drawing #:



INDOOR SPECIFICATION

Indoor Air Flow (Turbo/H/M/L/Si) (CFM)		588.6 / 518.0 / 447.3 / 341.4 / /
Indoor Noise Level (Turbo/H/M/L/Si) (dBA)		48.5/46/41/31/27
Dimension (W×D×H)	inch	40.94 x 8.66 x 12.87
	mm	1040.0×220.0×327.0
Package (W×D×H)	inch	44.09 x 15.94 x 12.40
	mm	1120×405×315
Net/Gross Weight	lbs	29.10/37.92
	kg	13.2/17.2

OUTDOOR SPECIFICATION

Compressor Type		ROTARY
Compressor Model		KTM240D46UKT2
Refrigerant		R454B
Refrigerant Oil Charge(mL)		620
Refrigerant Oil		VG74
Outdoor Air Flow (Max) (CFM)		1764.7
Outdoor Noise Level (dBA)		60.5
Dimension (W×D×H)	inch	35.04 x 13.46 x 26.50
	mm	890.0×342.0×673.0
Package (W×D×H)	inch	39.17 x 15.67 x 29.13
	mm	995×398×740
Net/Gross Weight	lbs	96.34/104.06
	kg	43.7/47.2

EFFICIENCY

Cooling		Heating	
SEER2	17.0	HSPF2-4	8.5
EER2	9.0	COP	2.78

PERFORMANCE of Cooling

Cooling (Btu/hr)	
Rated Capacity	24000
Min/Max Capacity	6400~24200
Moisture Removal(L/h)	3.2
Standard Operating Range(°F/°C)	5~122(-15~50)
Conditions:	Indoor: 80°F DB/67°F WB Outdoor: 95°F DB/75°F WB

PERFORMANCE of Heating

Heating (Btu/hr)	
1. @ 47°F Rated	24000
1. @ 47°F Min/Max Capacity	5800~27000
2. @ 17°F Rated	17100
3. @ 5°F Rated: Capacity / COP	17100/2.01
3. @ 5°F Max: Capacity	17100
Standard Operating Range(°F/°C)	5~72(-15~24)
1. Conditions:	Indoor: 70°F DB/60°F WB Outdoor: 47°F DB/43°F WB
2. Conditions:	Indoor: 70°F DB/60°F WB Outdoor: 17°F DB/15°F WB
3. Conditions:	Indoor: 70°F DB/60°F WB Outdoor: 5°F DB/5°F WB

ELECTRICAL

Power Supply	208/230V,60Hz,1Ph
System MCA	19.0
Connection Wiring	14#x4
System MOCP	20
Compressor RLA	13.8
Outdoor Fan Motor RLA	0.8
Outdoor Fan Motor W	80
Indoor Fan Motor RLA	0.8
Indoor Fan Motor W	45
System Power Input @ Cooling (W)	2667(340 ~ 2830)
System Power Input @ Heating (W)	2530(440 ~3010)
MCA: Min. circuit amps (A)	MOCP: Max. over current protection (A)
RLA: Rated load amps (A)	W: Fan motor rated output (W)

PIPING

Throttle type(Indoor)	N/A
Throttle type(Outdoor)	Throttle valve
Liquid Size	9.52mm(3/8in)
Gas Size	15.9mm(5/8in)
Max. Piping Length(ft/m)	164.00(50)
Max. Height Difference(ft/m)	82.00(25)
Max. Pre-charged Length(ft/m)	24.6(7.5)
Refrigerant Pre-charged Amount(oz/g)	54.67(1.55)
Additional Charge of Refrigerant((oz/ft)/(g/m))	0.32(30)
Connection Method	Flared

Indoor Unit Dimension

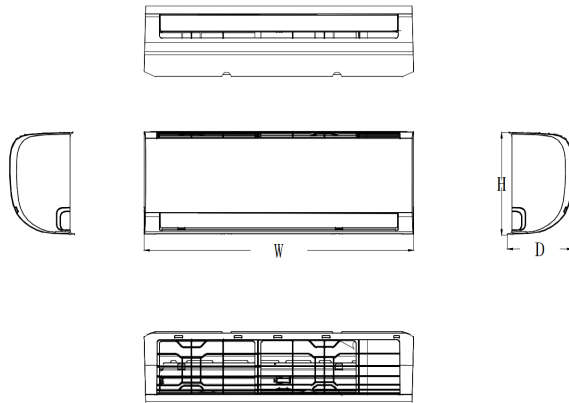

Capacity	Body Code	Unit	W	D	H
9k 115V	A	mm	715	194	285
		inch	28-1/8	7-5/8	11-1/4
9k-12k	B	mm	805	194	285
		inch	31-3/4	7-5/8	11-1/4
18k	C	mm	957	213	302
		inch	37-5/8	8-3/8	11-7/8
24k	D	mm	1040	220	327
		inch	41	8-5/8	12-7/8

Installation Instruction

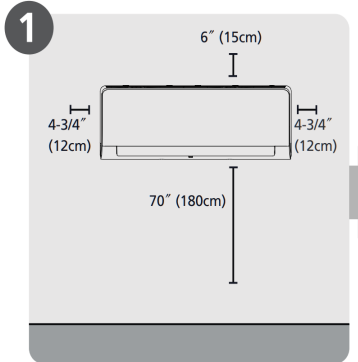

Select Installation Location

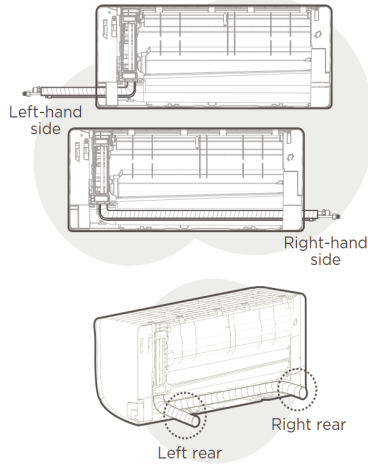

NOTE:
Based on the position of the wall hole relative to the mounting plate, choose the side from which the piping will exit the unit. You have four options for the exit direction of the piping.

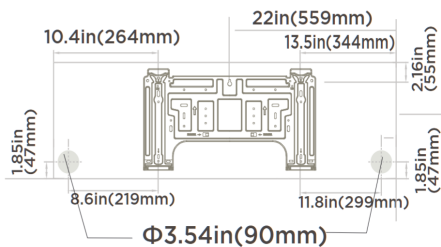

Indoor unit outline

NOTE:
When the gas side connective pipe is Φ (5/8in)16mm or more, the wall hole should be (3-1/2in)90mm.

Indoor unit dimensions:
40.85in(1037.6mm)x12.79in(324.9mm)

Outdoor Unit Dimension

35-1/4in(895mm)W3

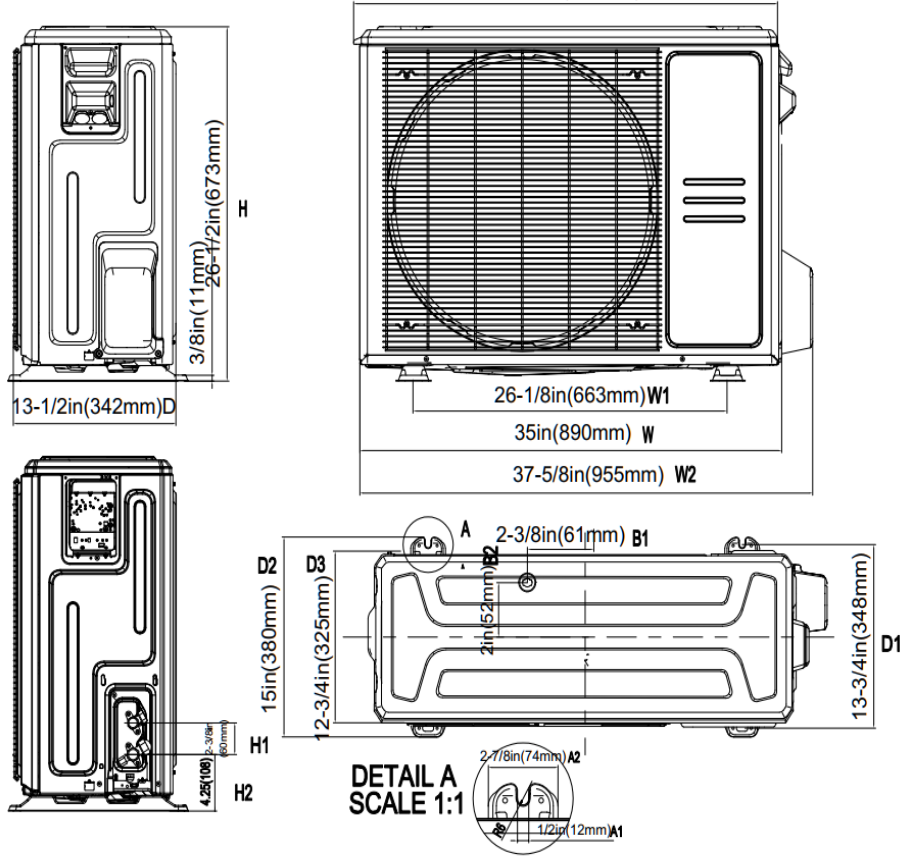

Installation Instruction

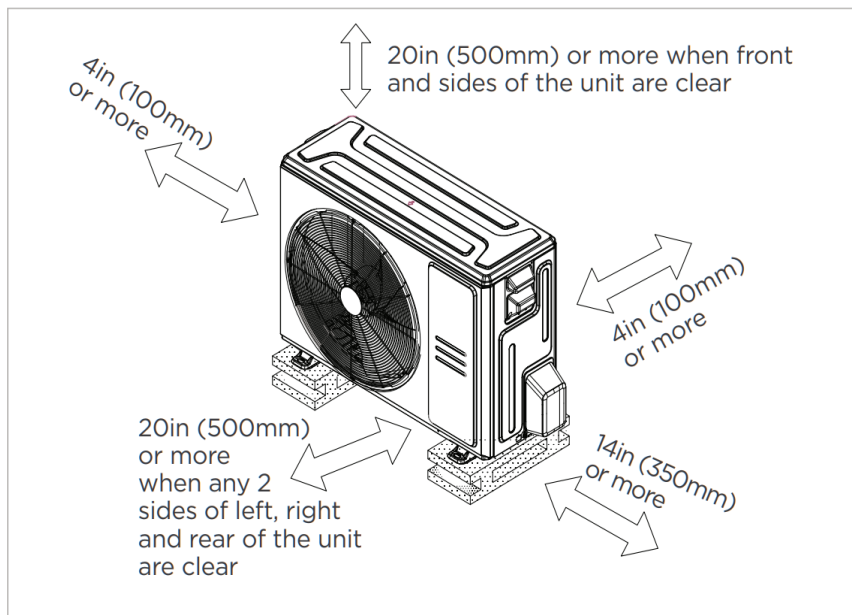

Meets all spatial requirements shown in Installation Clearance Requirements above.

FEATURES

- Indoor unit TU1 copper coil
- 1~100% fan speed setting
- WiFi capability: through WiFi dongle
- Multiple control options available:
 - Infrared wired controller: 120L
 - Wireless remote controller