

SUBMITTAL DATA SHEET

One Way Cassette Heat Pump System

Location:	Approval:
Engineer:	Date:
Submitted to:	Construction:
Submitted by:	Unit #:
Reference:	Drawing #:



INDOOR SPECIFICATION

Indoor Air Flow (Turbo/H/M/L/Si) (CFM)	400.2 / 352.0 / 300.2 / 207.2 / 207.2	
Indoor Noise Level (Turbo/H/M/L/Si) (dBA)	44/44/41/29.5/24	
Dimension (W×D×H)	inch	50.31 x 13.19 x 8.98
	mm	1278.0×335.0×228.0
Package (W×D×H)	inch	57.60 x 22.48 x 22.64
	mm	1463×571×575
Net/Gross Weight	lbs	45.19/82.89
	kg	20.5/37.6

OUTDOOR SPECIFICATION

Compressor Type	ROTARY	
Compressor Model	KSN140D58UFZ	
Refrigerant	R454B	
Refrigerant Oil Charge(mL)	440	
Refrigerant Oil	VG74	
Outdoor Air Flow (Max) (CFM)	1765.8	
Outdoor Noise Level (dBA)	57.5	
Dimension (W×D×H)	inch	35.04 x 13.46 x 26.50
	mm	890.0×342.0×673.0
Package (W×D×H)	inch	39.17 x 15.67 x 29.13
	mm	995×398×740
Net/Gross Weight	lbs	92.59/100.31
	kg	42.0/45.5

EFFICIENCY

Cooling		Heating	
SEER2	22.2	HSPF2-4	12.2
EER2	12.5	COP	3.30

PERFORMANCE of Cooling

Cooling (Btu/hr)	
Rated Capacity	18000
Min/Max Capacity	4000~18800
Moisture Removal(L/h)	2.08
Standard Operating Range(℉/℃)	-13~122(-25~50)
Conditions:	Indoor: 80℉ DB/67℉ WB Outdoor: 95℉ DB/75℉ WB

PERFORMANCE of Heating

Heating (Btu/hr)	
1. @ 47℉ Rated	18000
1. @ 47℉ Min/Max Capacity	7600~22800
2. @ 17℉ Rated	14000
3. @ 5℉ Rated: Capacity / COP	13100/2.24
3. @ 5℉ Max: Capacity	13100
Standard Operating Range(℉/℃)	-13~75(-25~24)
1. Conditions:	Indoor: 70℉ DB/60℉ WB Outdoor: 47℉ DB/43℉ WB
2. Conditions:	Indoor: 70℉ DB/60℉ WB Outdoor: 17℉ DB/15℉ WB
3. Conditions:	Indoor: 70℉ DB/60℉ WB Outdoor: 5℉ DB/5℉ WB

ELECTRICAL

Power Supply	208/230V,60Hz,1Ph
System MCA	18.00
Connection Wiring	14#x4
System MOCP	20
Compressor RLA	10.0
Outdoor Fan Motor RLA	0.9
Outdoor Fan Motor W	80
Indoor Fan Motor RLA	1.2
Indoor Fan Motor W	30
System Power Input @ Cooling (W)	1440(450 ~ 1660)
System Power Input @ Heating (W)	1600(400~1880)
MCA: Min. circuit amps (A)	MOCP: Max. over current protection (A)
RLA: Rated load amps (A)	W: Fan motor rated output (W)

PIPING

Throttle type(Indoor)	N/A
Throttle type(Outdoor)	EXV+Throttle valve
Liquid Size	6.35mm(1/4in)
Gas Size	12.7mm(1/2in)
Max. Piping Length(ft/m)	98.40(30)
Max. Height Difference(ft/m)	65.60(20)
Max. Pre-charged Length(ft/m)	24.6(7.5)
Refrigerant Pre-charged Amount(oz/kg)	47.97(1.36)
Additional Charge of Refrigerant((oz/ft)/(g/m))	0.16(15)
Connection Method	Flared

Indoor Unit Dimension

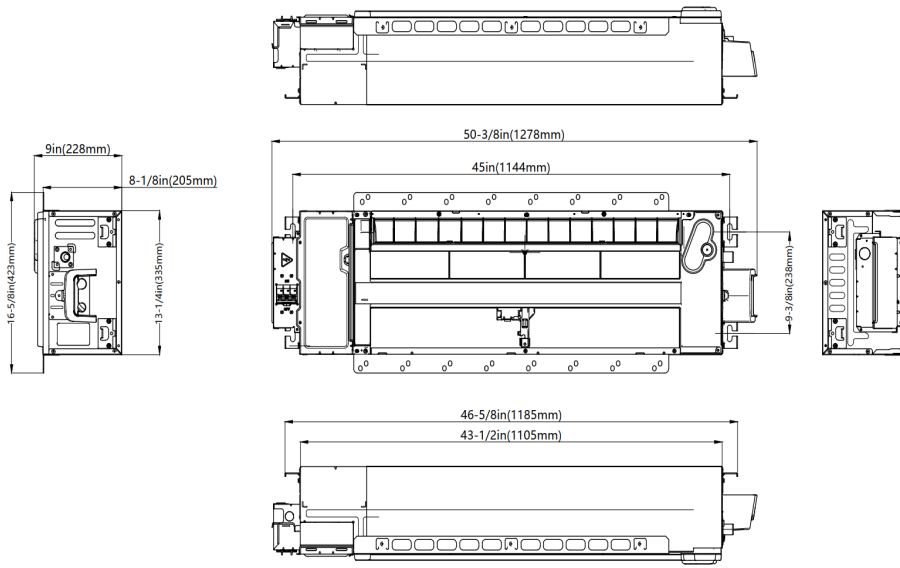

Installation Instruction

Installation place

(unit: inch/mm)

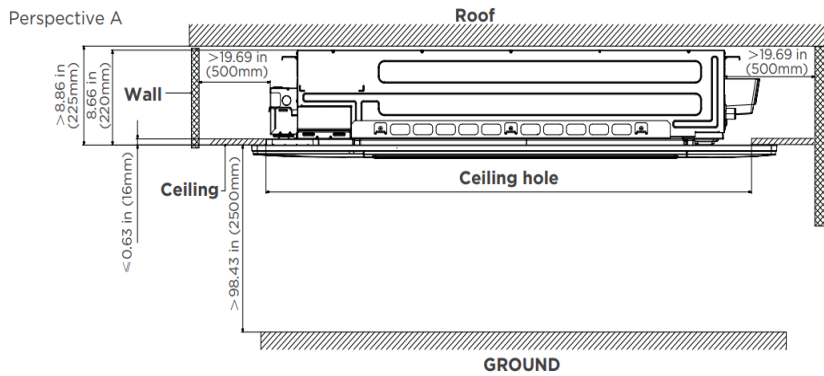

Perspective B

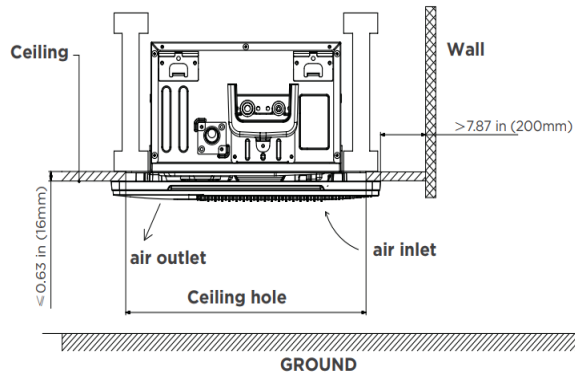

Outdoor Unit Dimension

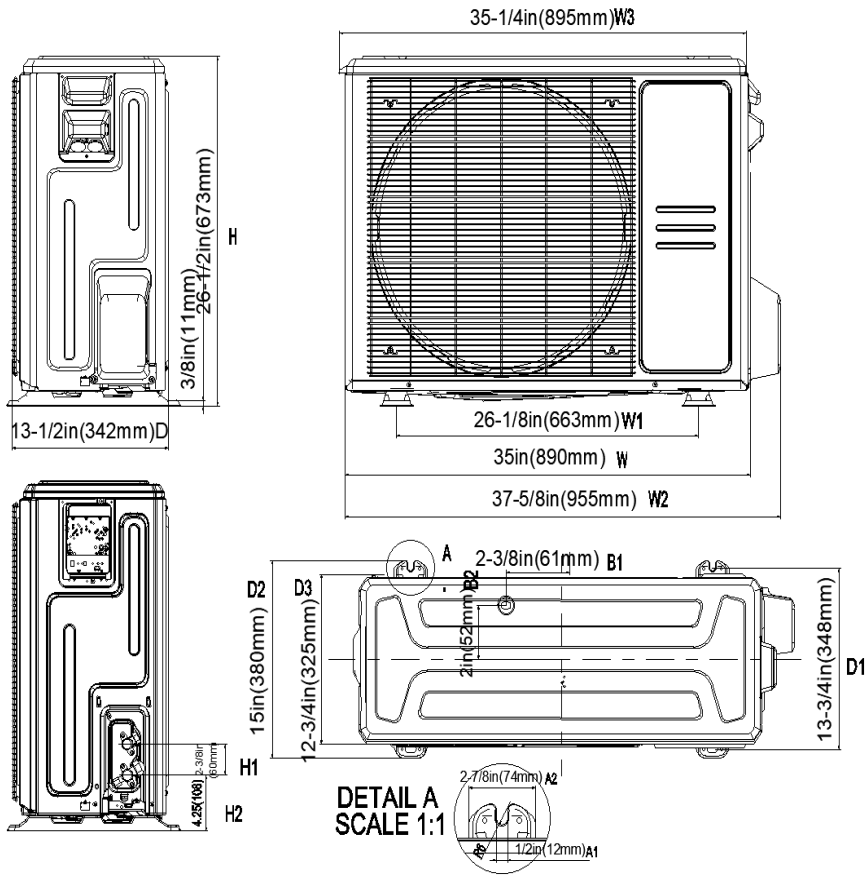

Installation Instruction

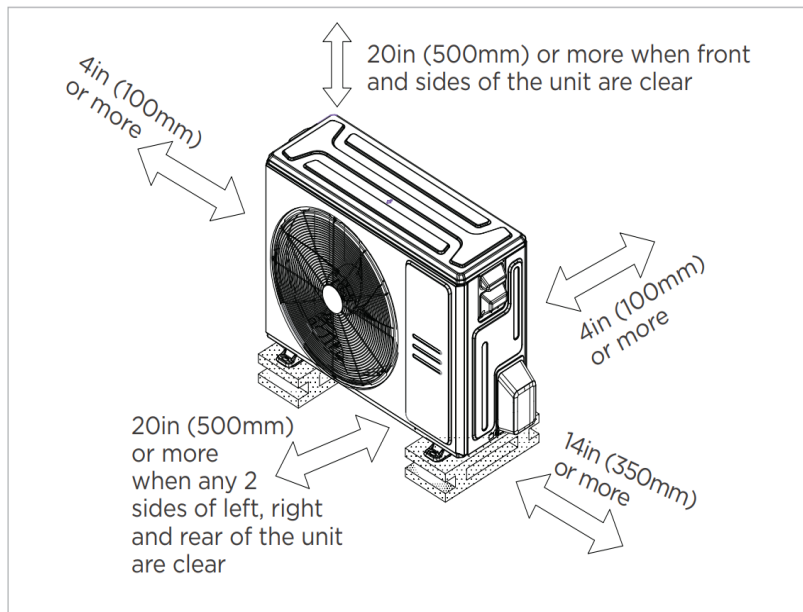

Meets all spatial requirements shown in Installation Clearance Requirements above.

FEATURES

- Designed to fit between both I-joint spacing and traditional joist spacing
- Elevation panel
- Refrigerant leakage detection sensor(Optional)
- Humidity sensor
- Built-in pump
- Built-in circuit breaker
- 1~100% fan speed setting
- WiFi capability: through WiFi dongle or wired controller with built-in WiFi
- OTA(by using WiFi dongle)
- 2-pin connector(HA/HB) for programmable wired controller
- Multiple control options available:
 - Two way communication wired controller:120N(X6)
 - Two way communication wired controller with built-in WiFi:120N(X6W)
 - Infrared wired controller: 120L
 - Wireless remote controller
 - Third-Party 24V Thermostat*

*24V interface is required.