

SERVICE MANUAL

PTAC SERIES

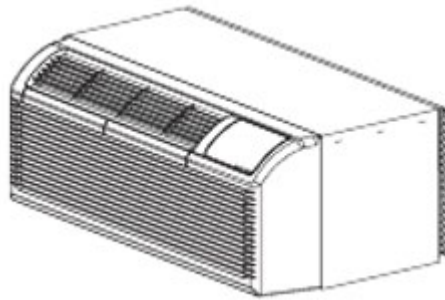

7,000-15,000 BTU/H

CONTENTS

□	1. Precaution.....	1
□	1.1 Safety Precaution.....	1
□	1.2 Warning.....	1
□	2. Functions and control panel	6
□	3. Dimension	9
□	4. Wiring Diagram	10
□	5. Refrigerant Cycle Diagram	11
□	6.Function and control panel.....	12
□	6.1 Terms and definitions.....	12
□	6.2 Electric Control working environment.....	12
□	6.3 Protection Function	12
□	6.4 Fan only mode	12
□	6.5 Cooling mode.....	12
□	6.6 Heating mode.....	13
□	6.7 Drying mode	15
□	6.8 DIP switches configurations	15
□	6.9 Dip switches configurations by panel control (Optional)	17
□	6.10 Wall Thermostat Terminal(Optional)	18
□	7. Unit components.....	21
□	8 Installation details.....	22
□	8.1 Before you get start	22
□	8.2 Before the installation	23
□	8.3 Installation overview.....	23
□	8.3 Care and clean.....	27
□	9 Operation characteristics.....	28
□	9.1 Cooling operation	28
□	9.2 Heating operation.....	28
□	10 Power connection options	29
□	11.Troubleshooting	31
□	11.1 Error Display	31
□	11.2 Troubleshooting	32

■ 1. Precaution

■ 1.1 Safety Precaution.

- **To prevent injury to the user or other people and property damage, the following instructions must be followed.**
- **Incorrect operation due to ignoring instruction will cause harm or damage.**
Before service unit, be sure to read this service manual at first.

■ 1.2 Warning

Installation

- **Do not use a defective or underrated circuit breaker. Use this appliance on a dedicated circuit.**
There is risk of fire or electric shock.
- **For electrical work, contact the dealer, seller, a qualified electrician, or an Authorized service center.**
Do not disassemble or repair the product, there is risk of fire or electric shock.
- **Always ground the product.**
There is risk of fire or electric shock.
- **Install the panel and the cover of control box securely.**
There is risk of fire of electric shock.
- **Always install a dedicated circuit and breaker.**
Improper wiring or installation may cause fore or electric shock.
- **Use the correctly rated breaker of fuse.**
There is risk of fire or electric shock.
- **Do not modify or extend the power cable.**
There is risk of fire or electric shock.
- **Do not install, remove, or reinstall the unit by yourself(customer).**
There is risk of fire, electric shock, explosion, or injury.
- **Be caution when unpacking and installing the product.**
Sharp edges could cause injury, be especially careful of the case edges and the fins on the condenser and evaporator.
- **For installation, always contact the dealer or an Authorized service center.**
There is risk of fire, electric shock, explosion, or injury.
- **Do not install the product on a defective installation stand.**

It may cause injury, accident, or damage to the product.

- **Be sure the installation area does not deteriorate with age.**

If the base collapses, the air conditioner could fall with it, causing property damage, product failure, and personal injury.

- **Do not let the air conditioner run for a long time when the humidity is very high and a door or a window is left open.**

Moisture may condense and wet or damage furniture.

- **Take care to ensure that power cable could not be pulled out or damaged during operation.**

There is risk of fire or electric shock.

- **Do not place anything on the power cable.**

There is risk of fire or electric shock.

- **Do not plug or unplug the power supply plug during operation.**

There is risk of fire or electric shock.

- **Do not touch (operation) the product with wet hands.**

There is risk of fire or electric shock.

- **Do not place a heater or other appliance near the power cable.**

There is risk of fire and electric shock.

- **Do not allow water to run into electric parts.**

It may cause fire, failure of the product, or electric shock.

- **Do not store or use flammable gas or combustible near the product.**

There is risk of fire or failure of product.

- **Do not use the product in a tightly closed space for a long time.**

Oxygen deficiency could occur.

- **When flammable gas leaks, turn off the gas and open a window for ventilation before turn the product on.**

Do not use the telephone or turn switches on or off. There is risk of explosion or fire.

- **If strange sounds, or small or smoke comes from product. Turn the breaker off or disconnect the power supply cable.**

There is risk of electric shock or fire.

- **Stop operation and close the window in storm or hurricane. If possible, remove the product from the window before the hurricane arrives.**

There is risk of property damage, failure of product, or electric shock.

- **Do not open the inlet grill of the product during operation. (Do not touch the electrostatic filter, if the unit is so equipped.)**

There is risk of physical injury, electric shock, or product failure.

- **When the product is soaked (flooded or submerged), contact an Authorized service center.**

There is risk of fire or electric shock.

- **Be caution that water could not enter the product.**

There is risk of fire, electric shock, or product damage.

- **Ventilate the product from time to time when operating it together with a stove, etc.**

There is risk of fire or electric shock.

- **Turn the main power off when cleaning or maintaining the product.**

There is risk of electric shock.

- **When the product is not be used for a long time, disconnect the power supply plug or turn off the breaker.**

There is risk of product damage or failure, or unintended operation.

- **Take care to ensure that nobody could step on or fall onto the outdoor unit.**

This could result in personal injury and product damage.

Caution

- **Always check for gas (refrigerant) leakage after installation or repair of product.**

Low refrigerant levels may cause failure of product.

- **Install the drain hose to ensure that water is drained away properly.**

A bad connection may cause water leakage.

- **Keep level even when installing the product.**

To avoid vibration of water leakage

- **Do not install the product where the noise or hot air from the outdoor unit could damage the neighborhoods.**

It may cause a problem for your neighbors.

- **Use two or more people to lift and transport the product.**

Avoid personal injury.

- **Do not install the product where it will be exposed to sea wind (salt spray) directly.**

It may cause corrosion on the product. Corrosion, particularly on the condenser and evaporator fins, could cause product malfunction or inefficient operation.

Operational

- **Do not expose the skin directly to cool air for long periods of time. (Do not sit in the draft).**
This could harm to your health.
- **Do not use the product for special purposes, such as preserving foods, works of art, etc. It is a consumer air conditioner, not a precision refrigerant system**
There is risk of damage or loss of property.
- **Do not block the inlet or outlet of air flow.**
It may cause product failure.
- **Use a soft cloth to clean. Do not use harsh detergents, solvents, etc.**
There is risk of fire, electric shock, or damage to the plastic parts of the product.
- **Do not touch the metal parts of the product when removing the air filter. They are very sharp.**
There is risk of personal injury.
- **Do not step on or put anything on the product. (outdoor units)**
There is risk of personal injury and failure of product.
- **Always insert the filter securely. Clean the filter every two weeks or more often if necessary.**
A dirty filter reduces the efficiency of the air conditioner and could cause product malfunction or damage.
- **Do not insert hands or other object through air inlet or outlet while the product is operated.**
There are sharp and moving parts that could cause personal injury.
- **Do not drink the water drained from the product.**
It is not sanitary could cause serious health issues.
- **Use a firm stool or ladder when cleaning or maintaining the product.**
Be careful and avoid personal injury.
- **Replace the all batteries in the remote control with new ones of the same type. Do not mix old and new batteries or different types of batteries.**
There is risk of fire or explosion.
- **Do not recharge or disassemble the batteries. Do not dispose of batteries in a fire.**
They may burn or explode.
- **If the liquid from the batteries gets onto your skin or clothes, wash it well with clean water. Do not use the remote if the batteries have leaked.**
The chemical in batteries could cause burns or other health hazards

Warning

- Do not use means to accelerate the defrosting process or to clean, other than those recommended by the manufacturer.
- The appliance shall be stored in a room without continuously operating ignition sources (for example: open flames, an operating gas appliance or an operating electric heater).
- Do not pierce or burn.
- Be aware that the refrigerants may not contain an odour.
- Compliance with national gas regulations shall be observed.
- Keep ventilation openings clear of obstruction.
- The appliance shall be stored so as to prevent mechanical damage from occurring.
- A warning that the appliance shall be stored in a well-ventilated area where the room size corresponds to the room area as specified for operation.
- Any person who is involved with working on or breaking into a refrigerant circuit should hold a current valid certificate from an industry-accredited assessment authority, which authorises their competence to handle refrigerants safely in accordance with an industry recognised assessment specification.
- Servicing shall only be performed as recommended by the equipment manufacturer. Maintenance and repair requiring the assistance of other skilled personnel shall be carried out under the supervision of the person competent in the use of flammable refrigerants.



Caution: Risk of fire/
flammable materials

■ 2. Functions and control panel

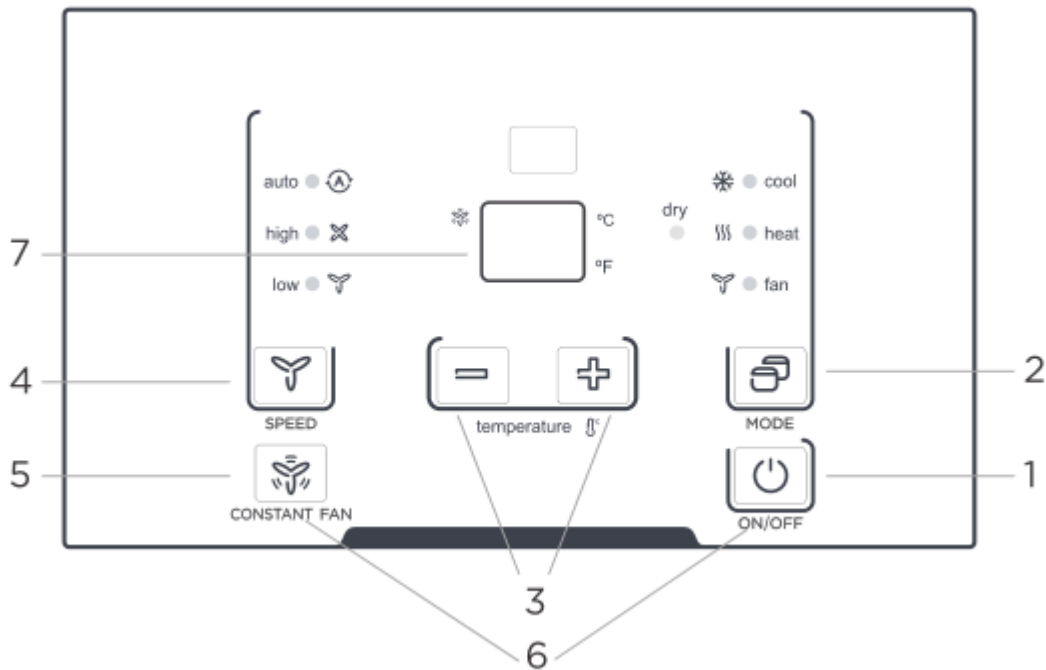

Description	
1	<p>POWER Function</p> <ul style="list-style-type: none"> · Press the POWER button to turn the unit on or of.
2	<p>Mode Function</p> <ul style="list-style-type: none"> · Push this button to cycle through the modes from COOL-DRY-HEAT-FAN-COOL. The indicator light beside the "MODE" option will illuminate, identifying the mode selected. · COOL: Cooling begins automatically when the room temperature is above the set point, and stops when the room temperature is 2°C(4°F)below the set point. But the compressor will run 5 minutes at least in COOL mode before stopping. · HEAT: For heat pump models, the unit can alternate to run between in reverse cycle heat mode and electric heater mode according to the difference between the setting temperature and the room temperature. · The fan motor cycles with the compressor stop. DRY : In this mode, the air conditioner will generally operate in the form of a dehumidifier. Since the conditioned space is a closed or sealed area, some degree of cooling will continue. NOTE: The reverse cycle and electric heater cannot be run at the same time. In following cases, it is normal that the reverse cycle does not operate. <ol style="list-style-type: none"> 1. When the outdoor temperature is lower than 4°C/40°F or the room temperature falls to 4.5°C/8°F below the set point temperature. 2. There is a 3-minute minimum compressor run time at any setting to prevent short cycling. The indoor fan motors starts before the compressor and stops after the compressor cycles of. 3. Push the S1 on the DIP SWITCHES to UP (ON) position. 4. When frost builds up to the evaporator coils, the unit will defrost automatically and the compressor will cycle of. NOTE: When you select AUTO mode, the FAN speed will be automatically adjusted at the setting temperature and room temperature. · FAN: Fan operation only without heating and cooling.

		NOTE: If the unit has DIP SWITCHES feature, the temperature range can be set is controlled by DIP SWITCHES. See DIP SWITCHES CONFIGURATIONS for details.
3	Up and Down buttons	· Push the UP (or DOWN) button to increase (or decrease) the set temperature of the unit in cooling or heating mode. The temperature can be set by increments of 1°C (1°F).The setting temperature appears in the display. NOTE: Press and hold “+”and“-” buttons together for 3 seconds will alternate the temperature display between °C &°F scale.
4	FAN (FAN SPEED) - Function	- Every time you push this button, the fan speed cycles through the settings as follows: AUTO-HIGH-LOW-AUTO. NOTE: When you select AUTO mode, the FAN speed will be automatically adjusted at the setting temperature and room temperature. On Dry mode, the fan speed is controlled at Low speed automatically.
5	CONSTANT FAN - Function	· In cooling mode, press the button to turn on or of the constant fan function. When the function is turned on, the constant fan light will illuminate, identifying the fan continuous run for cooling. When the function is turned off, the constant fan light will go out, identifying the fan cycle run with compressor stop. NOTE: Every time the unit is turned on, the function will work as the DIP SWITCHES CONFIGURATIONS.
6	PANEL LOCKING - Function	· Long press the open key and continuous air function key for 5 seconds at the same time. Quick check immediately response, no 5 seconds. Turn on or of the lock panel function. The remote control still works. Fast entry, and exit when unlocking function. NOTE: It will be display 'LL' when you locked the control panel.
7	DISPLAY	· Shows the set temperature in °C or °F. While on Fan only mode, it shows the room temperature. Control code (on some models): LC - Pads on the control panel is not available. The unit can be set by using wire controller only. FC - Pads on the control panel and wire controller are not available. The unit can be set by using FRONT DESK CONTROL only. Error codes: E0-EEPROM parameter error E3-The indoor fan speed is operating outside of the normal range E4-Main control and Display communication error AS - Room temperature sensor error; ES - Evaporator temperature sensor error; CS - Condenser temperature sensor error; OS - Outside temperature sensor error; HS - Exhaust temperature sensor error; LE - Drive-by-wire control failure; NOTE: When error occurs, unplug the unit and plug it back in. If error repeats, call for service. Other codes: LO - Room temperature is lower than 0°C/32°F; HI - Room temperature is higher than 37°C/99°F; FP - Low temp. Protection. NOTE: All the illustrations in this manual are for explanation purpose only. Your air conditioner may be slightly different. The actual shape shall prevail.

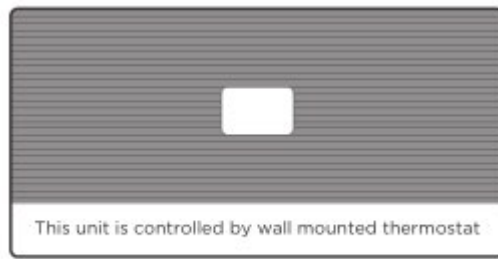

Control panel sticker

NOTE: When the unit displays LC (Pads on the control panel is not available. The unit can be set by using wire controller only). You can install the Accessory on the control panel.

NOTE: For some models, there is corresponding operation happened after 3 seconds when pressing any button.

■ 3. Dimension

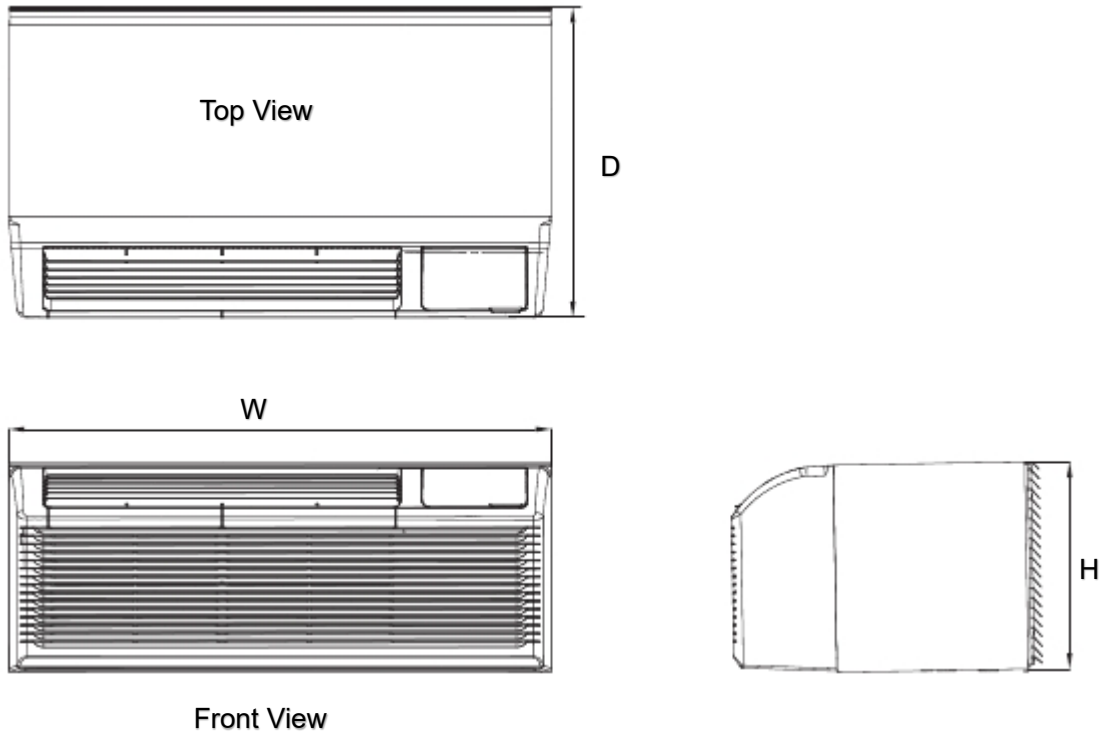

Dimension	WxHxD (mm)
	WxHxD (inch)
Dimension 1 (no sleeve, rear grille and rear net)	1067x406x532
	42.0x15.9x20.9
Dimension 2 (no rear grille and rear net, but include sleeve)	1067x408x578
	42.0x16.0x22.8
Dimension 3 (include sleeve and rear net)	1067x408x588
	42.0x16.0x23.1
Dimension 4 (include sleeve, rear net and rear grille)	1067x408x606
	42.0x16.0x23.9

■ 4. Wiring Diagram

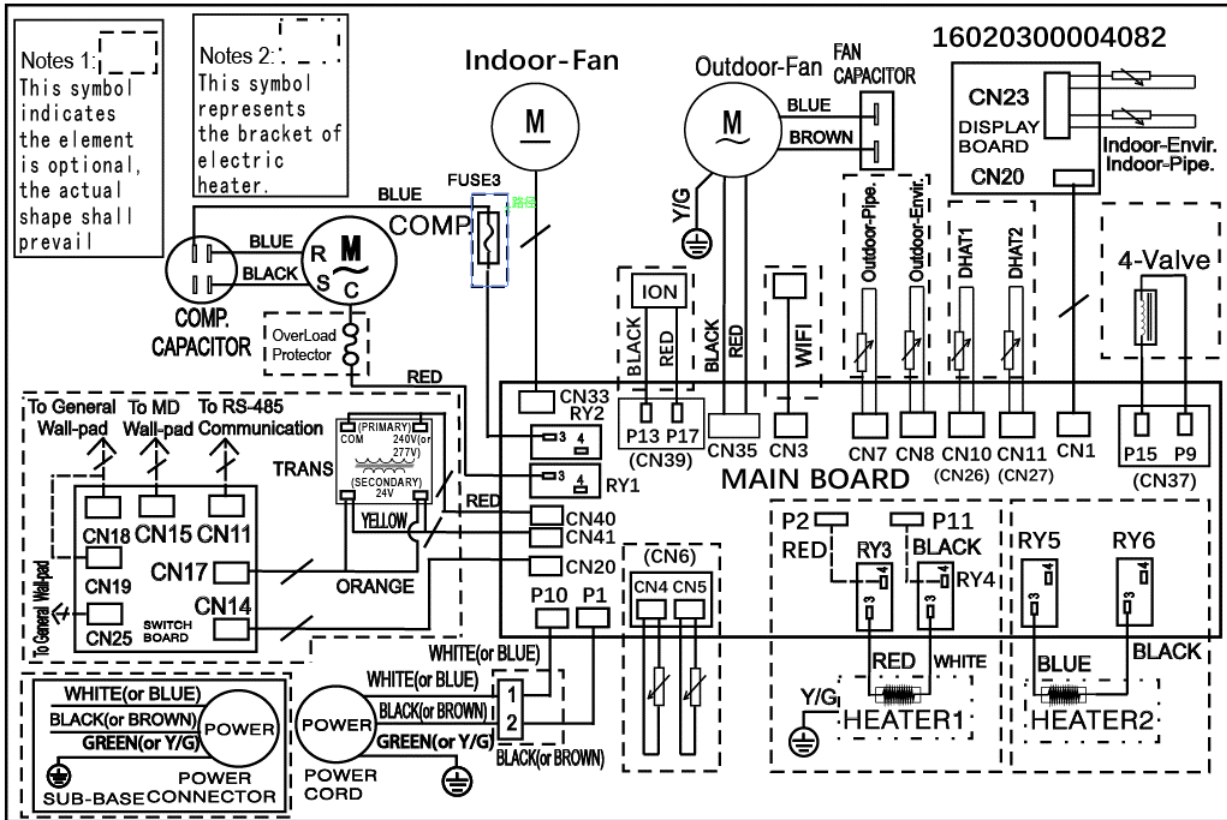

■ 5. Refrigerant Cycle Diagram

The figure below is a brief description of the important components and their function in what is called the refrigerant system.

This will help to understand the refrigeration cycle and the flow of the refrigerant in the Heat Pump Cycle.

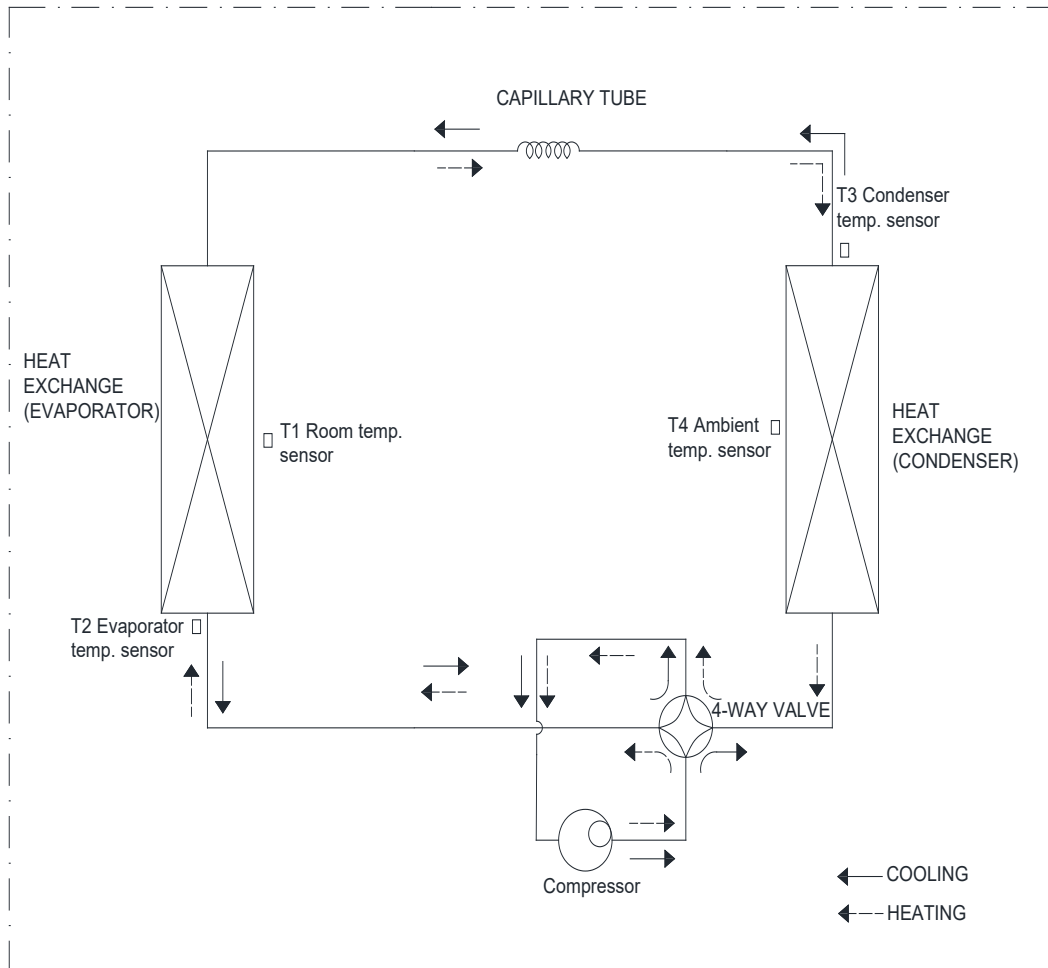

■ 6.Function and control panel

■ 6.1 Terms and definitions

TA: Temperature of indoor ambient(T1)

TE: Temperature of evaporator(T2)

TC: Temperature of condenser(T3)

TO: Temperature of outdoor ambient(T4)

TS: The set temperature.

DAHT: Temperature of discharge (T5)

DAHT: Temperature of discharge (T6)

■ 6.2 Electric Control working environment

Input voltage: 265V, 60Hz(MWBUP-07AEN8-UK9, MWBUP-09AEN8-UK3, MWBUP-12AEN8-UJ5& MWBUP-15AEN8-UI6) or 208/230V, 60Hz(other models)

■ 6.3 Protection Function

6.3.1 The compressor functions protection with a delay of three minutes.

6.3.2 Sensor protection at open or short circuit.

6.3.3 Evaporator anti-freezing protection in cooling mode and dry mode.

■ 6.4 Fan only mode

6.4.1 Temperature control is disabled, and the room ambient temperature is display on LED.

6.4.2 The Timer function is valid in this mode.

6.4.3 Compressor, outdoor fan, electric heater and 4-valve cease operation.

■ 6.5 Cooling mode

6.5.1 The speed of indoor fan can be optionally chosen as Auto/High/Low.

Auto fan:

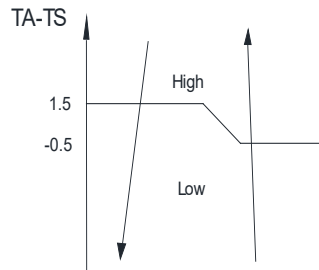

When the fan is running at low speed, if $TA \geq TS + 1.5^{\circ}\text{C}(3^{\circ}\text{F})$, the fan motor will operate at high speed

When the fan is running at high speed last for 1 minute, if $TA \leq TS - 0.5^{\circ}\text{C}(1^{\circ}\text{F})$, the fan motor will operate at low speed

6.5.2 Operation of outdoor fan motor

The operation of outdoor fan is consistent with the operation of compressor. (except the T2 low temperature protection).

6.5.3. Compressor Running Guidelines

The compressor will be activated by sensing the difference between setting temperature and the actual ambient room temperature.

The compressor operates as below:

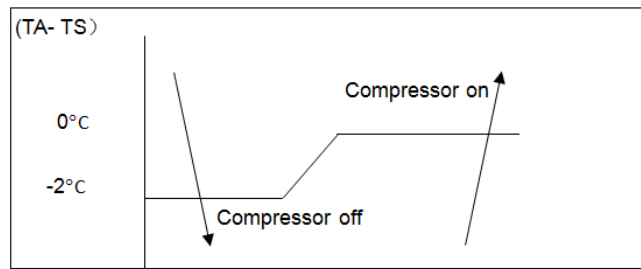

6.5.4 The Timer/ Sleep/ Energy Saver/ Follow Me functions are valid in the cooling mode.

6.5.5 Evaporator Anti-freezing Protection

When evaporator temperature drops below $2^{\circ}\text{C}(4^{\circ}\text{F})$ last for 240s, the compressor and outdoor fan cease operation.

■ 6.6 Heating mode

6.6.1 The speed of indoor fan can be optionally chosen as Auto/High/Low.

Auto fan:

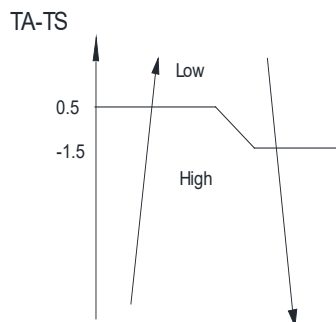

When the fan is running at low speed, if $TA \leq TS - 1.5^\circ\text{C}$ (3°F), the fan motor will operate at high speed

When the fan is running at high speed last for 1 minute, if $TA \geq TS + 0.5^\circ\text{C}$ (1°F), the fan motor will operate at low speed

6.5.2 Operation of outdoor fan motor

The operation of outdoor fan is consistent with the operation of compressor. (except the T2 high temperature protection).

6.6.3. Compressor Running Guidelines

The compressor will be activated by sensing the difference between setting temperature and the actual ambient room temperature.

The compressor operates as below:

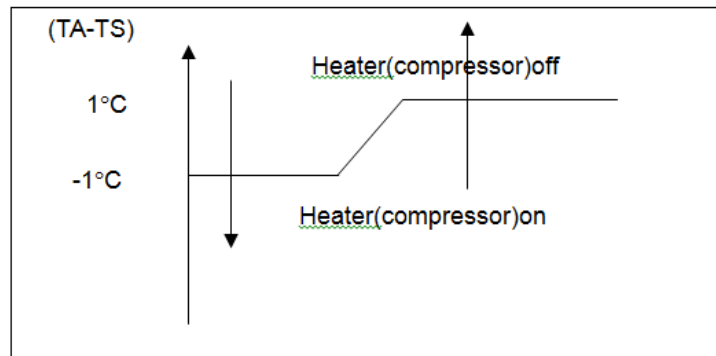

6.6.4 The high temperature protection of evaporator as below:

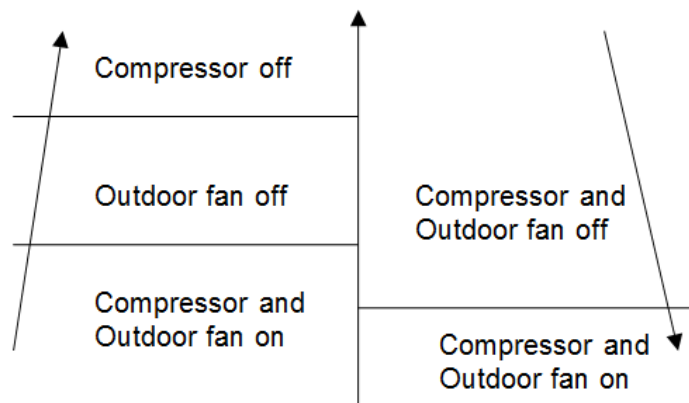

6.6.5 The Electric heater operates as below:

- When $TA < Ts - 1^\circ\text{C}$ (2°F), the fan motor operates, and fan speed is higher than 800RPM for 3 seconds, the heater is on and when fan speed is below 700RPM for 3 seconds, the heater is off. The indoor fan operates at low speed within 30 seconds. After 30 seconds, it changes to the setting speed.
- When $TA \geq Ts + 1^\circ\text{C}$ (2°F), the heater is off, and the fan motor keeps on working at setting speed. If the DAHT temperature checked is lower than the protection temperature, and the operation time of fan motor is more than 15 seconds, then the fan motor is off.
- If the DAHT temperature checked is higher than the protection temperature, the heater is off and the fan motor keeps on working. Until the DAHT temperature checked is lower than the protection temperature, the heater is on.
- If the DAHT temperature sensor is in open circuit or has short circuited, the heater is off and the fan

motor is off 30 seconds later.

e. If the ambient temperature sensor is in open circuit or has short circuited, the heater is off and the fan motor is off 30 seconds later.

6.6.6 The Heat pump operates as below:

1. The Heat pump's operation mode is in accordance with the way of compressor's working. The compressor is on (electric heater is off), the fan motor operates according to the anti-cold wind of heat pump. The four-way valve always keeps on. When $TA < Ts - 1^{\circ}\text{C} (2^{\circ}\text{F})$, the compressor is on, and when $TA \geq Ts + 1^{\circ}\text{C} (2^{\circ}\text{F})$, it will be off. Before starting the compressor, the indoor fan motor should run for 10 seconds first. TA is not judged within 5 minutes after starting the compressor, but it is judged immediately if the set temperature is changed.
2. Anti-cold air function
When the compressor is started, the fan runs at low speed for 3 minutes, then if indoor coil temperature T2 is lower than $27^{\circ}\text{C} (80^{\circ}\text{F})$, the fan runs at low speed still, if indoor unit coil temperature T2 is higher than $30^{\circ}\text{C} (86^{\circ}\text{F})$, it changes to the setting speed.
3. When the compressor is turned off, when the indoor coil temperature T2 is lower than $27^{\circ}\text{C} (80^{\circ}\text{F})$, indoor fan stops running, otherwise the indoor fan runs at low speed, but the longest time is less than 30 seconds.

■ 6.7 Drying mode

6.7.1. Indoor fan speed is fixed at low and can't be changed.

6.7.2. Compressor control is the same as in cooling mode.

6.7.3 All protections are active and the same as that in cooling mode.

■ 6.8 DIP switches configurations

Note: Unit must be powered OFF to effectively change their status.

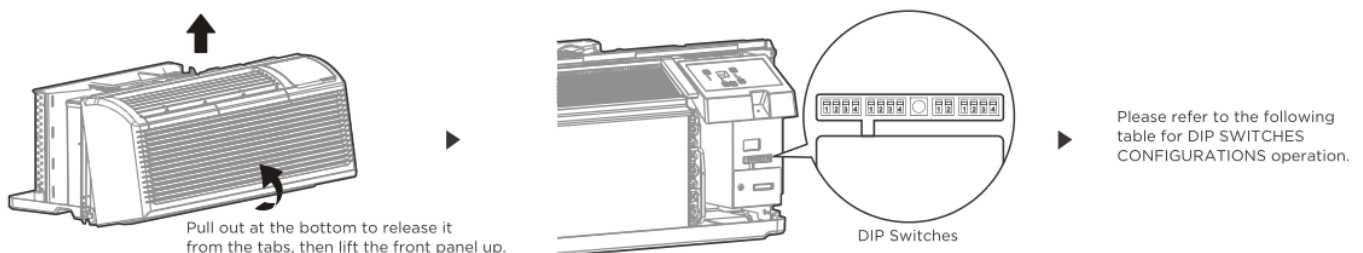

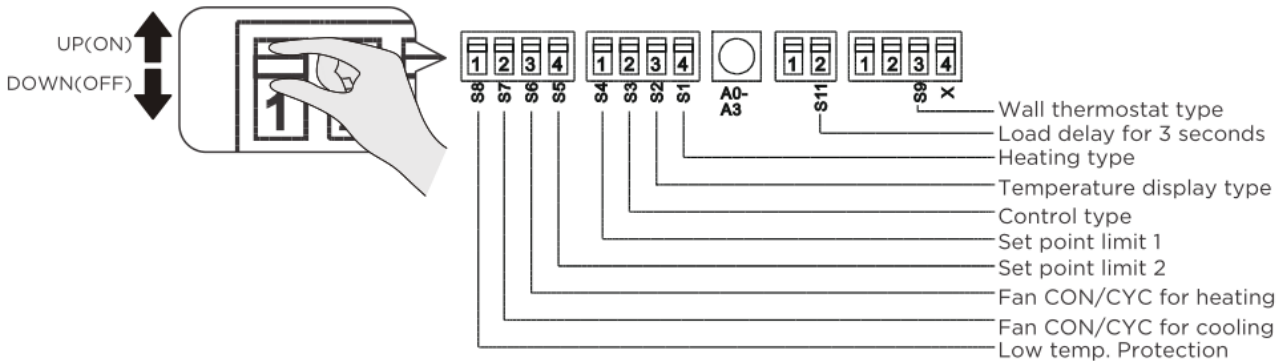

Table 1- DIP SWITCHES CONFIGURATIONS

No.	UP(ON)	DOWN(OFF)	Remarks
S1	Electric Heat Only	Electric Heat and Pump Heat	For Heat Pump unit only
S3	Wall Thermostat Enable	Control Panel Enable	
S4*S5	UP*UP:60°F~86°F(16°C~30°C); UP*DOWN:65°F~78°F(18°C~26°C); DOWN*UP:63°F~80°F(17°C~27°C); DOWN*DOWN:68°F~75°F(20°C~24°C);		Two configurations (S4*S5) combine to select set point range.
S6	Fan Continuous Run for Heating	Fan Cycle for Heating	
S7	Fan Continuous Run for Cooling	Fan Cycle for Cooling	
S8	Low temp. Protection enable	Low temp. Protection disable	Optional
S9 (S3UP)	Use other types of wall Thermostat	Use other types of wall Thermostat	you can consult with the sales agency or manufacturer for details
S9 (S3DOWN)	Use Control Panel only	Use Control Panel or other types of wall Thermostat	Use control Panel or some types of wall Thermostat, the other one must be turned off
S11	Load delay for 3 seconds	Normal	Optional

*** Electric Heat Only (for heat pump unit only)**

- This setting is typically used for Emergency Heating.

*** Wall Thermostat Enable**

- A wired wall thermostat can be connected to the unit .If it is, this dip switch must be moved to the Wall Thermostat Enable Position, before the wall thermostat will begin control.

*** Set-point Temperature Limits**

- Provides a restricted range of temperature control.

.Heat and Cool Fan CON/CYC Dip-switches

- Allows the fan to operate in continuous or cycle modes while the unit is in heating and cooling mode.

*** Continuous (CON)**

- Allows fan to run continuously, circulating air even when the temperature setting has been satisfied. This switch helps to maintain the room temperature closer to the thermostat setting.

*** Cycle (CYC)**

- This setting allows the fan to cycle on and off with the compressor or electric heater. The fan stops a short time after the temperature setting is satisfied.

■ 6.9 Dip switches configurations by panel control (Optional)

Note: Unit must be powered OFF to effectively change their status.

- Press the up and down buttons together for 3 seconds to activate the dip switches configurations by panel control (see Fig).

- See Table 2 for Dip Switches configurations and functions by panel control.

NOTE: Press the up and down buttons together for 3 seconds again or no operation within 30 seconds to exit the dip switches configurations by panel control and the unit will save the last settings.

- Display function settings with 2 digitals in LED display window, high (left) for dip switches, low (right) for functions (see Fig).

- Press up button to set the dip switches, press down button to set the functions.

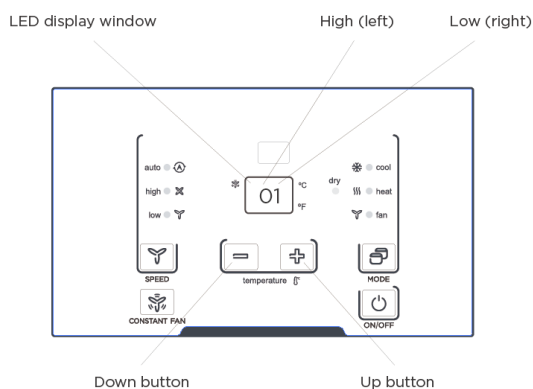

Table 2 DIP SWITCHES CONFIGURATIONS by PANEL CONTROL

No.	High(left)	Low(right)		Remarks
/	0	1-by panel control	0-by dip switches	
S1	1	1-electric heat only	0-electric heat and pump heat	For Heat Pump unit only
S3	3	3-use control panel or some types of wall thermostat; 2-use other types of wall thermostat; 1-use other types of wall thermostat; 0-control panel enable.		You can consult with the sales agency or manufacturer for details
S4*S5	4	4:62°F~86°F(17°C~30°C); 3:60°F~86°F(16°C~30°C); 2:65°F~78°F(18°C~26°C); 1:63°F~80°F(17°C~27°C); 0:68°F~75°F(20°C~24°C);		
S6	6	1-fan continuous run for heating	0-fan cycle for heating	Not available for "use PTAC other wall thermostat".
S7	7	1-fan continuous run for cooling	0-fan cycle for cooling	
S8	8	1-low temp. protection enable	0-low temp. protection disable	Optional
SW7	A	1-front desk control disable	0-front desk control enable	Optional
S11	B	1-Load delay for 3 seconds	0-normal	Optional

Note:

1. The LED display window will show “00” when you first enter the setting mode, only when you set “01” you can start the next settings.
2. To activate front desk control function, you need to pull the dip switch SW7 to DOWN(OFF), and then set the Panel control to A0.
3. After all set, press up (+) and down (-) buttons together for 3 seconds to exit the operation interface and cut off the power. When re-power on, the settings are activated.

■ 6.10 Wall Thermostat Terminal(Optional)

IMPORTANT: Only trained, qualified personnel should access electrical panel on unit and install electrical accessories. Please contact your local electrical contractor, dealer, or distributor for assistance.

1. Thermostat Wire Routing

Thermostat wire is field supplied. Recommended wire gauge is 18 to 20 gauge solid thermostat wire. **NOTE:** It is recommended that extra wires are run to unit in case any are damaged during installation. Thermostat wire should always be routed around or under, **NEVER** through, the wall sleeve. The wire should then be routed behind the front panel to the easily accessible terminal connector.

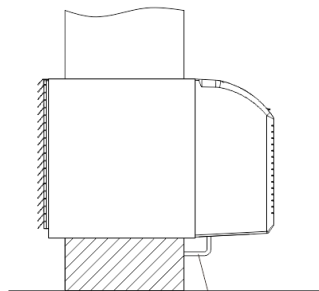

THERMOSTAT WIRE ROUTING
(UNDER SLEEVE, BEHIND FRONT PANEL)

Fig. A - Proper Wire Routing Beneath Unit

NOTE: Refer to thermostat installation instructions for details on installing wall thermostat.

2. Installation instruction of some types of wall Thermostat (you can consult with the sales agency or manufacturer for details)

- Pull the dip switch to the DOWN(OFF) position as shown below.

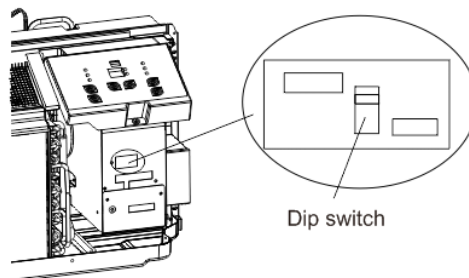

- Insert the wire connector of the wall thermostat into the relevant terminal according to different shapes as shown below.

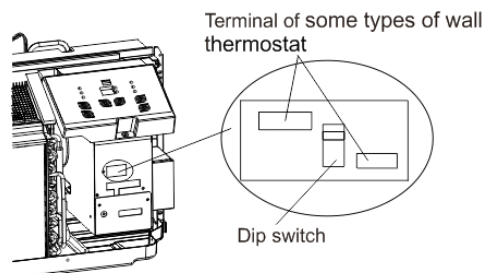

3. Installation instruction of PTAC other Wall Thermostat

- Remove the two screws as shown below and take the cover panel down.

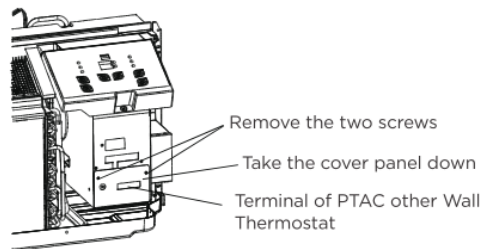

Terminal of PTAC Wall Thermostat (MODE A)

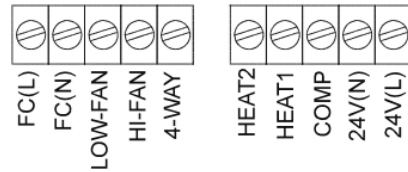

Terminal of PTAC Wall Thermostat (MODE B)



TERMINAL	DESIGNATION	MODE B Wire color
FC(L)	Front desk control terminal L	Brown
FC(N)	Front desk control terminal N	Pink
LOW-FAN	Low fan speed	Purple
HI-FAN	High fan speed	Green
4-WAY	4-way valve; Reverse cycle (Energized in Heat) For heat pump models	Blue
HEAT2	Electrical heater 2	White
HEAT1	Electrical heater 1	White
COMP	Compressor	Yellow
24V(N)	24VAC terminal N(Neutral),Common	Black
24V(L)	4VAC terminal L	Red

Caution: UNIT DAMAGE HAZARD

- Failure to follow this caution may result in equipment damage or improper operation.
- Improper wiring may damage unit electronics. Common busing is not permitted. Damage or erratic operation may result.

Note:

- Use terminal 4-way for heat pump connection only.
- Suggest set the compressor protection time more than 3 minutes in wall thermostat. If set less than 3 minutes, the compressor will restart delay 3 minutes still.
- Wall thermostat must be heating changeover 4-way valve.
- For thermostats that have only one fan speed output (on or auto),the fan speed is determined by how the terminal connector is wired. If Low fan is desired, wire the G output from the thermostat to (LOW-FAN) on the units terminal block.
- If High fan is desired, wire the G output from the thermostat to (HI-FAN) on the

units terminal block.

- The range of set temperature of Wall thermostat must be in consonance with the range of DIP switch setting.
- Wall thermostat must be set the type properly in consonance with the unit type : heat pump or no heat pump.
- If the Wall thermostat has only one electrical heater output, connect the two terminals of HEAT 1 and HEAT 2, the unit can operate two electrical heaters(only for the unit has two electrical heaters). Otherwise operate one electrical heater.
- Please do not remove the control panel.

4. FRONT DESK CONTROL

The controller can handle a switch signal from FC(L) and FC(N) input, called front desk control. Input must be 24VAC. If system doesn't receive a 24VAC signal, it will turn unit off; otherwise, the unit runs in normal control.

- The DIP switch can control the FRONT DESK CONTROL feature. The DIP switch is on the DOWN position, the unit will be turn off; otherwise, the unit runs in normal control.

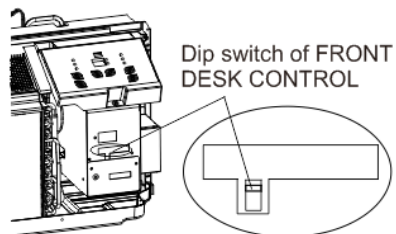

■ 7. Unit components

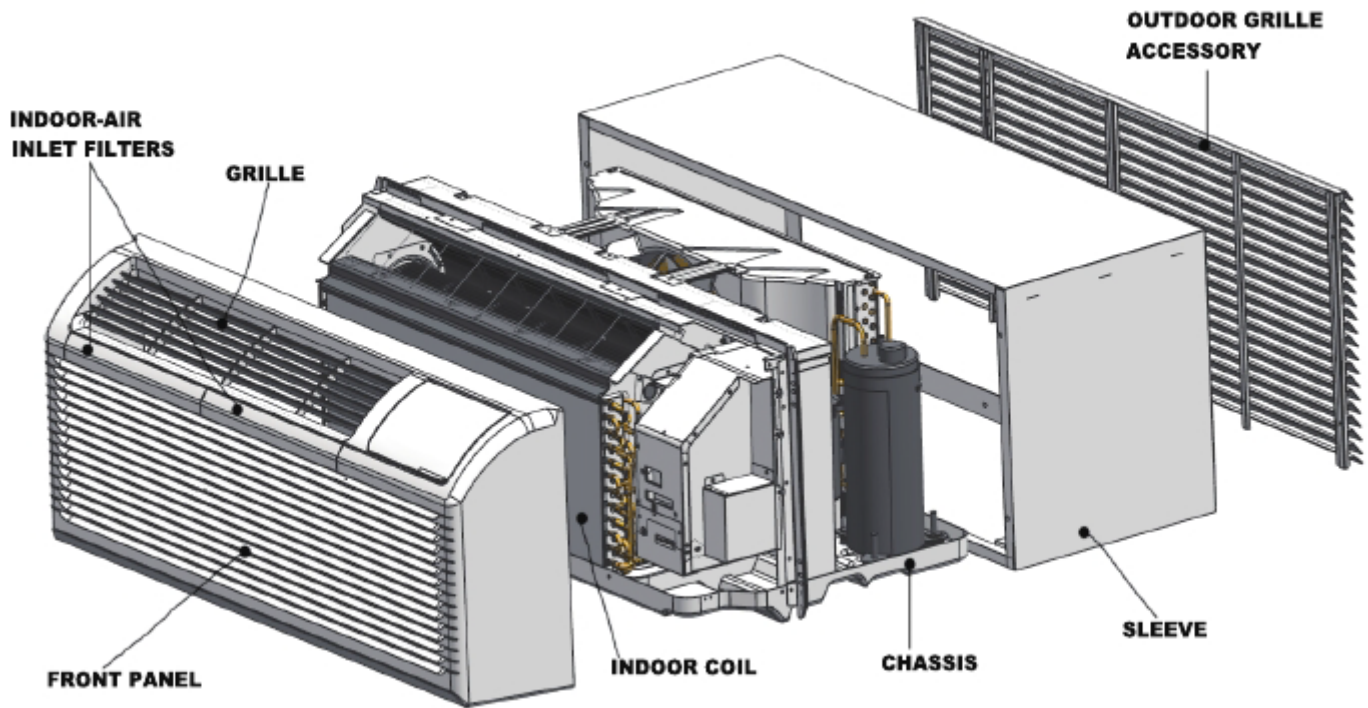

Decomposition figure

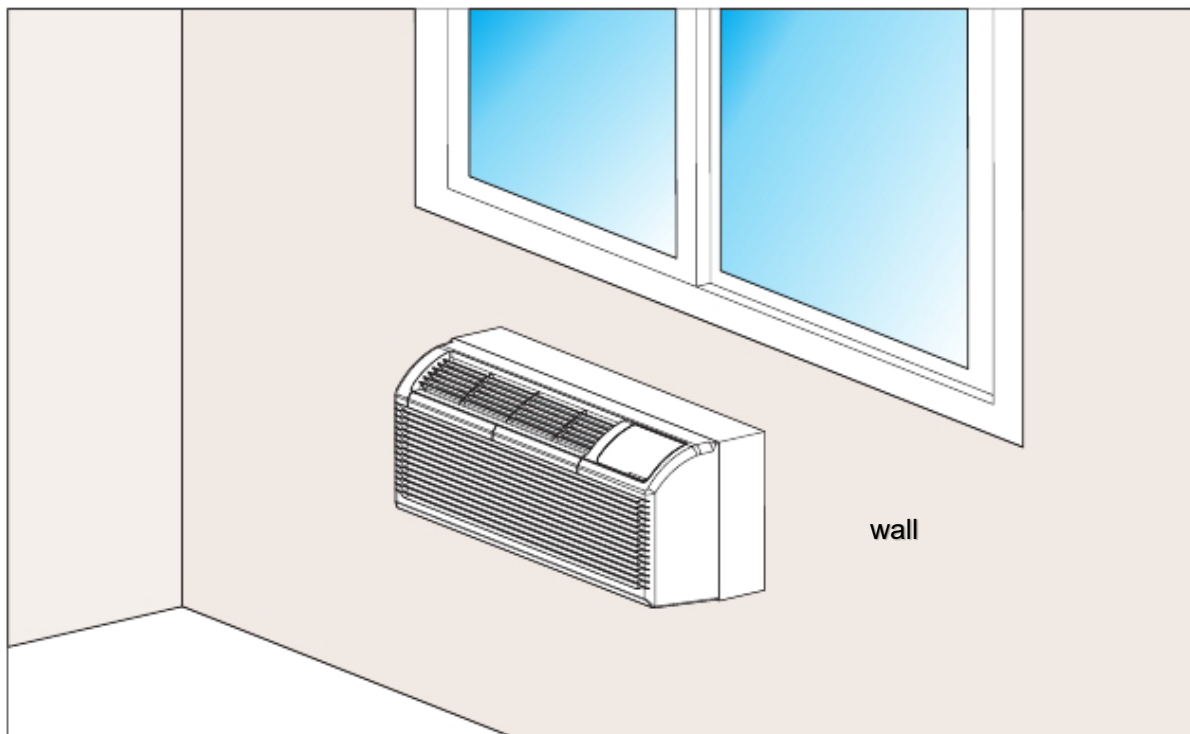

Installation figure

■ 8 Installation details

■ 8.1 Before you get start

What is in the Package

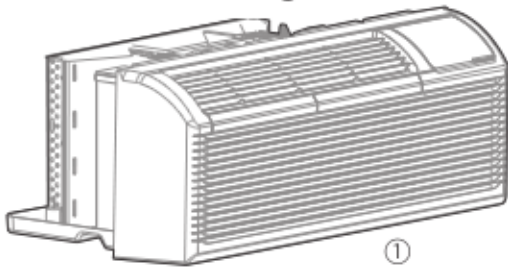

- ① Unit
- ② Control panel sticker
- ③ Owner's manual

Subbase kit (for 265V model only, optional)



- ① Subbase
- ② Cover panel I
- ③ Cover panel II
- ④ Screws x8

Subbase kit Model: MWP-S3500/20A (used for cord connected units with 3.5kw Electric Heater)

What you need to purchase

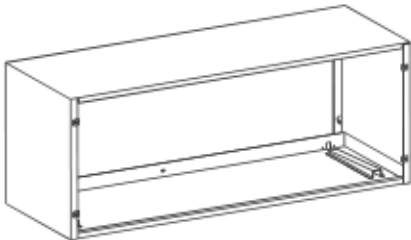

Wall sleeve

*Not Included

Prepare the following tools



Gloves



Screwdriver



Pencil



Drill



Ruler or tape measure



Level

*Not Included

8.2 Before the installation



The installation must be carried out in strict accordance with the instructions in this manual.



Installing your AC should take about 60 minutes.



We recommend doing this with a helper.



We're here if you need us, please contact your local distributor for assistance.

INSTALLATION SIZE AND POSITION REQUIREMENTS

CAUTION

Be careful! There are sharp edges that can cause serious cuts.

Installation size confirmation :

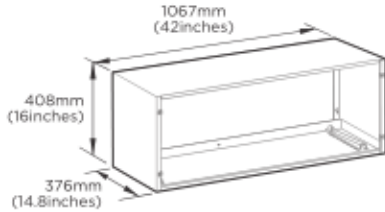

Wall sleeve size requirements (wall hole size should refer to the wall sleeve size)

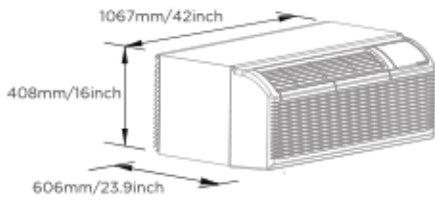

Product size

Confirmation of installation position :

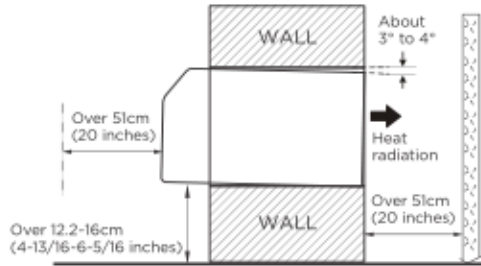

NOTE

To make the appliance work better, please do not place a barrier in the air outlet.

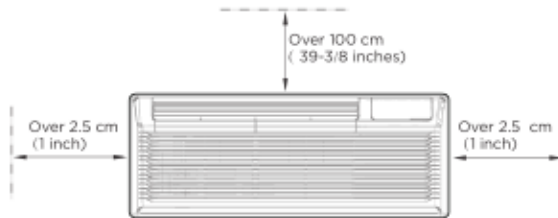

8.3 Installation overview

Installing Unit into the wall

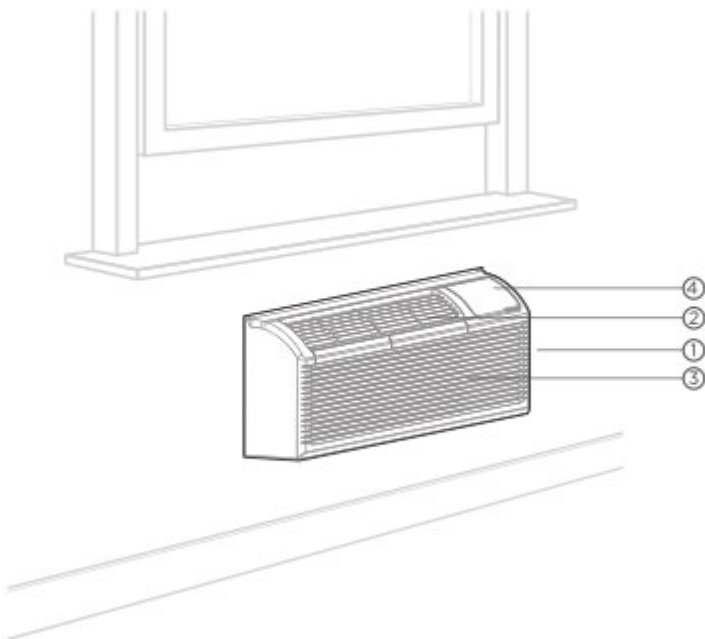

- ① Unit
- ② Outlet
- ③ Air Intake
- ④ Control panel cover

NOTE

Illustrations in this manual are for explanatory purposes. The actual shape of your unit may be slightly different. The actual shape shall prevail.

Type1: Instructions for non-265V models

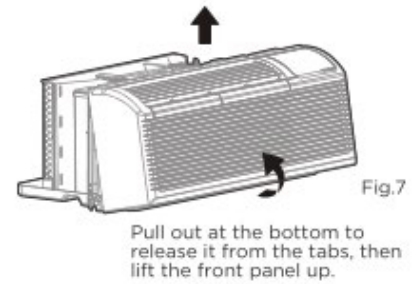
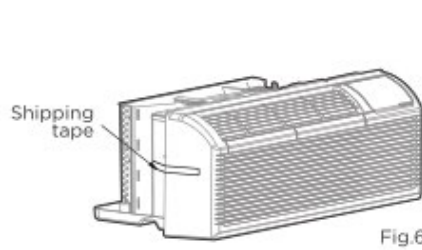
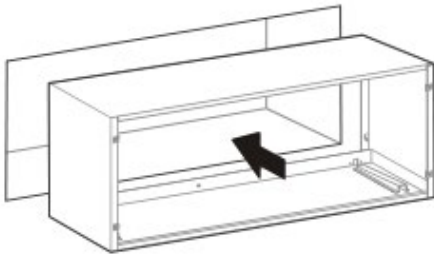

1

Attach Wall sleeve.

Refer to the installation instruction of sleeve assembly for details. To avoid vibration and noise, make sure the wall sleeve is installed securely and firmly.

2

Prepare for unit installation.

Carefully remove shipping tapes from the front panel. (See Fig.6)
Remove the front panel. (See Fig.7)

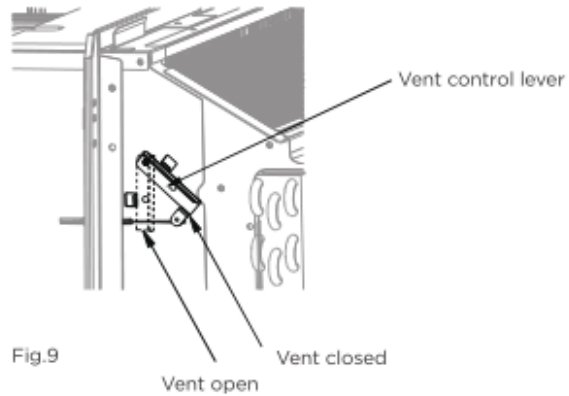
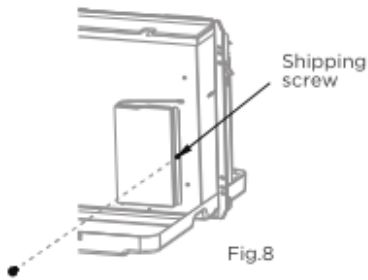

3

Install and fix the main part of the unit.

Remove the shipping screw from the vent door. (See Fig.8)

Rotate the vent control lever to either open or close the vent door. (See Fig.9)



NOTE:

When vent control lever set at CLOSE, only the air inside the room is circulated and filtered. When set at OPEN, some outdoor air will be drawn into room. This will reduce heating or cooling efficiency.



CAUTION:

- Do not put obstacles around air-inlet or inside of air-outlet of the unit, such as window curtain etc.
- Always insert the filter securely, clean filter once every two weeks as required.

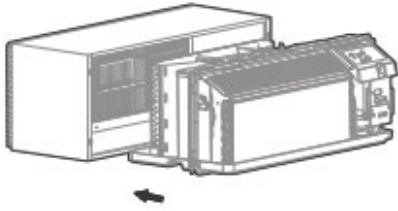

Fig.10

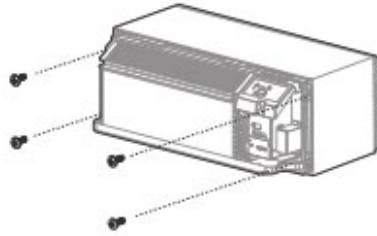

Fig.11

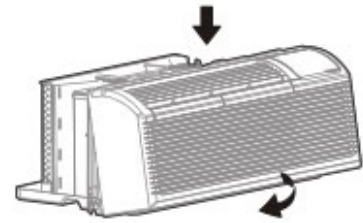

Fig.12

4

Install the unit into the wall sleeve

Lift unit level and slide unit into wall sleeve until firmly against front of wall sleeve and secure with 4 screws and washers (supplied in the SLEEVE ASSEMBLY) through the unit flange holes.

Type 2: Instructions for 265V model (Optional)

Complete Subbase kit installation

CAUTION

- When the model you purchase is 265V model, install it with Subbase kit and connect power wiring on site.
- The product plug must be inserted into the power jack of the Subbase kit for use.
- All wiring operations and power requirements must be operated and used in accordance with local regulations and policies.

WARNING:

- To avoid the risk of property damage, personal injury or death due to electrical shock, disconnect the electrical power before working on this product.
- The instructions provided with the selected subbase kit must be carefully followed. It is the responsibility of the installer to ensure the connection of components is done in accordance with these instructions and national wiring regulations.
- Before performing any electrical or wiring work, turn off the main power to the system.

What you need.



5

Reinstall front panel.

Place tabs over top rail . Push Inward at bottom until panel snaps into place. (See Fig.12)

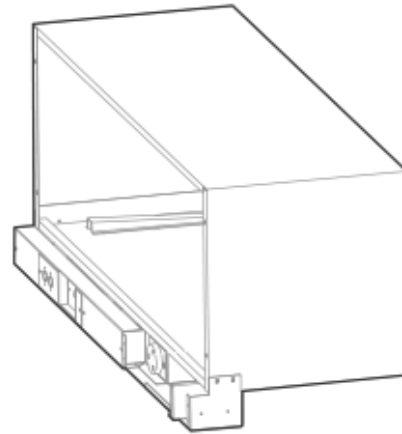

Electronic Work (for 265V model only)

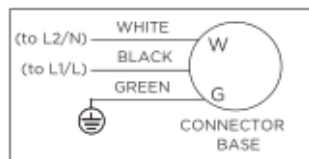

NOTE:

- The cographs are for explanation purpose only. Your machine may be slightly different. The actual shape shall prevail.
- An all-pole disconnection mean should be installed to connet the subbase and main power supply.

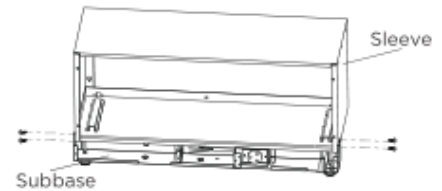
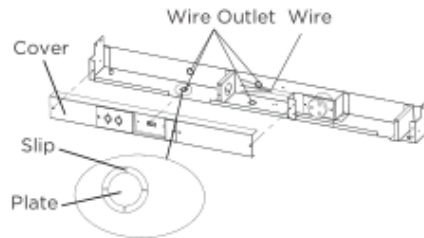
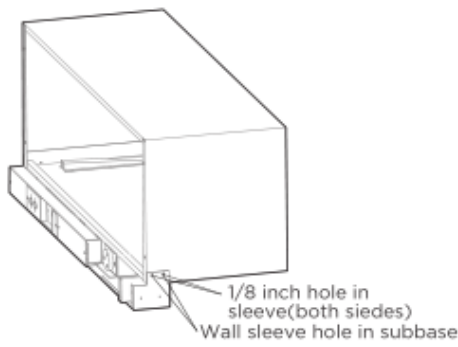

1

Drill four 1/8-inch holes.

Drill four 1/8-inch holes in the sleeve to line up with the wall sleeve holes in subbase as shown below.

2

Prepare for unit subbase's wiring.

Remove the COVER by loosening 3 screws, select one from the four wire outlets according to your need and remove the plate by clipping four slips as shown below. Then burnish the wire outlet and spray anticorrosive paint to it to avoid cutting and rusting the wires. Insert conduit into the wire outlet and connect the wires of the conduit with the SUBBASE in accordance with all electrical codes.
NOTE: Make sure the appliance is properly grounded.

3

Install the subbase to the sleeve.

Install the SUBBASE to the SLEEVE with four screws as shown above and tighten them.

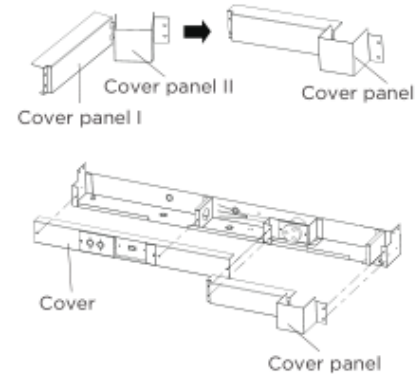
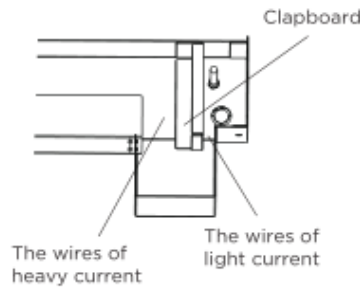
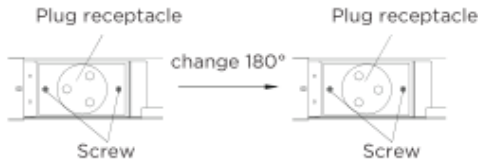
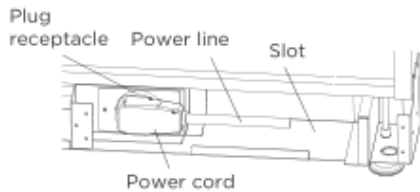

4

Install the unit to the sleeve.

Install the unit into the SLEEVE (refer to the installation instructions of the unit) and plug the power cord of the unit into the plug receptacle of the SUBBASE as shown below. The power line can be wound and placed in the slot of the SUBBASE.

NOTE: The direction of the plug receptacle can be changed 180° by loosening two screws and restall it as shown below so that it is suitable for different power cord.

5

Assemble the Subbase.

Resert the COVER PANEL II into the COVER PANEL I and rotate a certain angle as shown. And install the COVER and COVER PANEL to the SUBBASE with 7 screws securely as shown.

NOTE: The wires of heavy current shall be placed in the left of the clapboard, and the wires of light current shall be placed in the right of it as shown below. The appliance shall be installed in accordance with national wiring regulations.

■ 8.3 Care and clean

⚠ CAUTION

- **UNIT DAMAGE HAZARD** Failure to follow this caution may result in equipment damage or improper operation. Airflow restriction may cause damage to the unit.

FRONT PANEL AND CASE

- Turn unit off and disconnect power supply. To clean, use water and a mild detergent. use bleach and abrasivers. Some commercial cleaners may damage the plastic parts.

OUTDOOR COIL

- Coil on outdoor side of unit should be checked regularly. Unit will need to be removed to inspect dirt build-up that will occur on the inside of the coil. If clogged with dirt and soot ,coil should be professionally cleaned. Clean inside and outside of outdoor coils regularly.

NOTE: Never use a high-pressure spray on coil.

⚠ CAUTION

Failure to follow this caution may result in equipment damage or improper operation.

- Do not operate unit without filters in place. If a filter becomes torn or damaged, it should be replaced immediately.
- Operating without filters in place or with damaged filter will allow dirt and dust to reach indoor coil and reduce cooling, heating, airflow and efficiency of unit. Airflow restriction may cause damage to unit.

- The most important thing you can do to maintain unit efficiency is to clean the filters once every two weeks as required. Clogged filters reduce cooling, heating and airflow.

- Keeping filters clean will:

Decrease cost of operation.

Save energy.

Prevent clogged indoor coil.

Reduce risk of premature component failure.

-Removing Air Filter

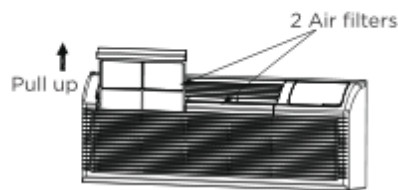

Fig. 13

- To Clean Air Filters:

Vacuum off heavy soil. Run water through filter. Dry thoroughly before replacing.

-Replacing Air Filter



Fig. 14

- VENT DOOR FILTER:

IMPORTANT:TURN UNIT OFF BEFORE CLEANING.

- If the vent door is open, access requires the removal of the unit from the wall sleeve. Clean the vent filter twice a year or as required.
- Make sure to remove the shipping screw from the vent door. (See. Fig.8)
- Rotate the vent control lever to open the vent door. (See. Fig.15)
- Remove four screws from the vent door filter. (See. Fig.15)
- First pull out the vent door steel wire from the hole of the vent door, then take off the vent door and filter. (See. Fig.15)
- Clean the filter. Dry thoroughly before replacing.
- Replac the vent door and filter, reinstall the four screws.
- Reinsert the vent door steel wire into the hole of the vent door.

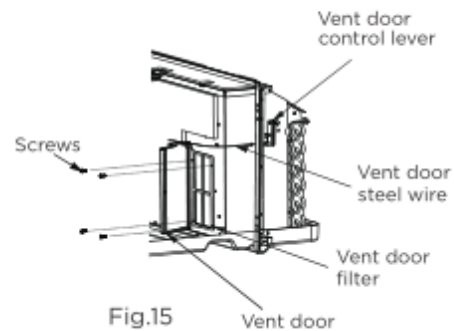
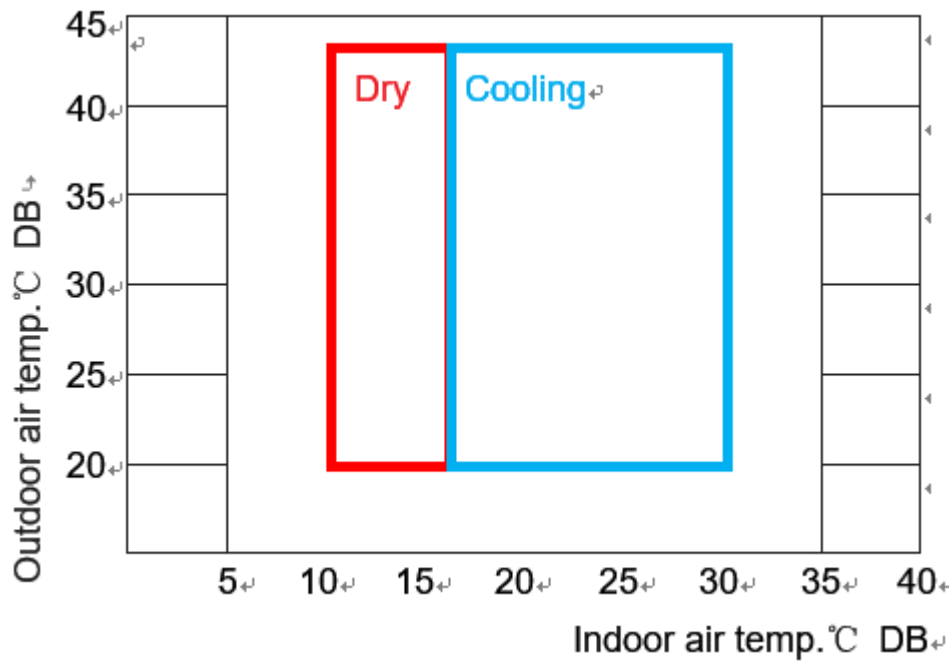

Fig.15

■ 9 Operation characteristics

■ 9.1 Cooling operation



■ 9.2 Heating operation

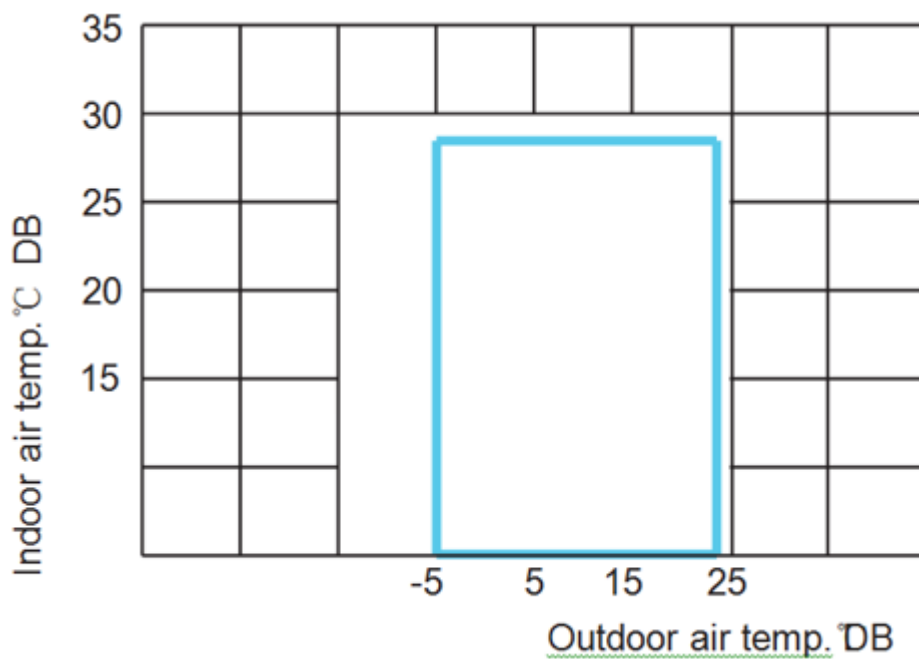

■ 10 Power connection options

Appropriate power cord accessory kit is determined by the voltage, and amperage of the branch circuit. The unit does not come with a power cord (or hard wire kit). An accessory power cord must be ordered to connect the unit to the outlet. If the unit is to be hard wired, an accessory hard wire kit must be ordered.

IMPORTANT:

For 265V units, if a power cord is selected, it must plug into the 265V subbase accessory.

Cord-connected Units

The 240V field supplied outlet must match the plug for the standard 208/230V units and be within reach of the service cord. The standard cord-connected 265V units require an accessory electrical subbase for operation.

Power Cord Protection

The power cord for 230/208v units provide power cord fire protection. Unit power automatically disconnects when unsafe conditions are detected. Power to the unit can be restored by pressing the reset button on plug head. Upon completion of unit installation for 230/208V models, an operational check should be performed using the TEST/RESET buttons on the plug head.

NOTE:

The 265V models do not incorporate this feature as they require use of the electrical subbase accessory. Our sub base accessory is being developed

Power Card						
Power Supply	230V,15A	230V,20A	230V,30A	265V,15A	265V,20A	265V,30A

POWER CONNECTION CHART

UNIT MODEL	CODE OF POWER SUPPLY KIT	
	15A	20A
	208 / 230 V	208 / 230 V
MWBUP-07EEN8-MM1	6-15P(15A / 240V)	
MWBUP-07AEN8-MM1		
MWBUP-09EEN8-MK3		6-20P(20A / 240V)
MWBUP-09EEN8-ML8		
MWBUP-09AEN8-MK3		
MWBUP-09AEN8-ML8		
MWBUP-12AEN8-MJ5		
MWBUP-12EEN8-MJ7		
MWBUP-12EEN8-MK6		

MWBUP-12AEN8-MK6		
MWBUP-15EEN8-MJ6		
MWBUP-15AEN8-MJ6		
	265 V	265 V
MWBUP-07AEN8-UK9		7-20P(20A / 277V)
MWBUP-09AEN8-UK3		
MWBUP-12AEN8-UJ5		
MWBUP-15AEN8-UI6		

■ 11.Troubleshooting

■ 11.1 Information Inquiry

To enter engineer mode, in power-on or standby mode, and in non-locked state, press the key combination “+, - & mode” for 5s:

Code	Query Content	Displaying code	Meaning
0	Error code	Na	
1	T1	T1	T1 temp.
2	T2	T2	T2 temp.
3	T3	T3	T3 temp.
4	T4	T4	T4 temp.
5	Reserve		
6	Reserve		
7	Reserve		
8	Reserve		
9	Reserve		
10	Indoor capacity test	Sn	
11	Reserve		
12	Outdoor fan speed	Pr	Outdoor fan speed
13	Reserve		
14	Indoor fan speed	lr	Indoor fan speed
15	Reserve		
16	Reserve		
17	After-sales bar code writing	SH	
18	WIFI signal strength	IF	
19	Reserve		
20	Reserve		
21	Temperature of discharge (T5)	T5	
22	Temperature of discharge (T6)	T6	
23	Filter time	FL	

Exit conditions:

1. Engineering mode is displayed for 10 minutes in 17 channels and exits after 1 minute in other channels.
2. Switch on/off, change mode, fan speed or set temperature, exit the engineering mode.

■ 11.2 Error Display

Codes	Contents
AS	Open or short circuit of T1 temperature sensor
ES	Open or short circuit of T2 temperature sensor
CS	Open or short circuit of T3 temperature sensor
oS	Open or short circuit of T4 temperature sensor
HS	Open or short circuit of T5 or T6 temperature sensor
Lo	Temperature is lower than display range(0°C/32°F)
HI	Temperature is higher than display range(37°C/99°F)
FP	Low temp. Protection
E4	Communication malfunction between main control board and display board.
LE	Drive-by-wire control failure
E0	EEPROM parameter error
E3	The indoor fan speed is operating outside of the normal range

■ 11.2 Troubleshooting

11.2.1 Open circuit or short circuit of temperature sensor diagnosis and solution(AS/ES/CS/oS/HS)

Error Code	AS/ES/CS/oS/HS
Malfunction decision conditions	If the sampling voltage is lower than 0.06V or higher than 4.94V, the LED will display the failure.
Supposed causes	<ul style="list-style-type: none"> ● Wiring mistake ● Faulty sensor

Troubleshooting:

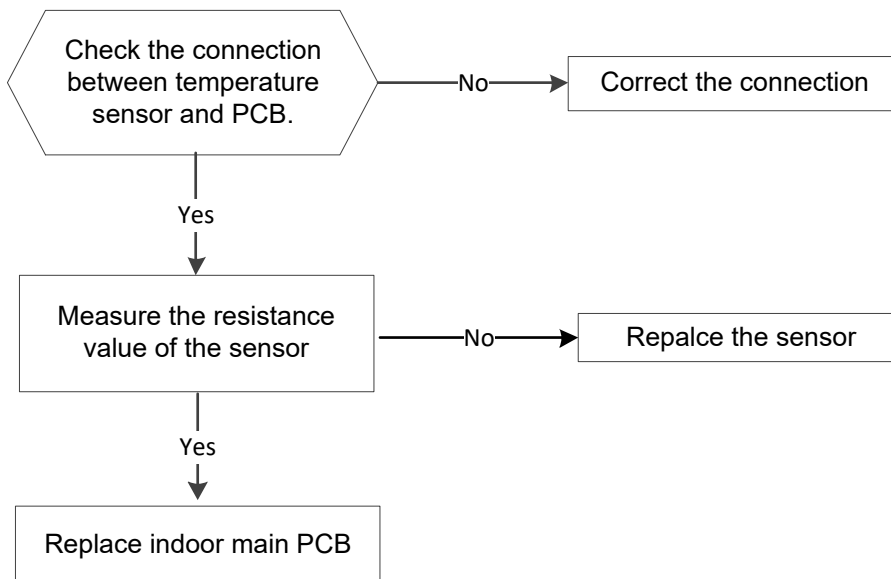

11.2.2 Communication malfunction between main control board and display board. (E4)

Error Code	E4
Malfunction decision conditions	Main control board does not receive feedback from display board during 120 seconds.
Supposed causes	<ul style="list-style-type: none"> ● Wiring mistake ● Faulty display board

Troubleshooting:

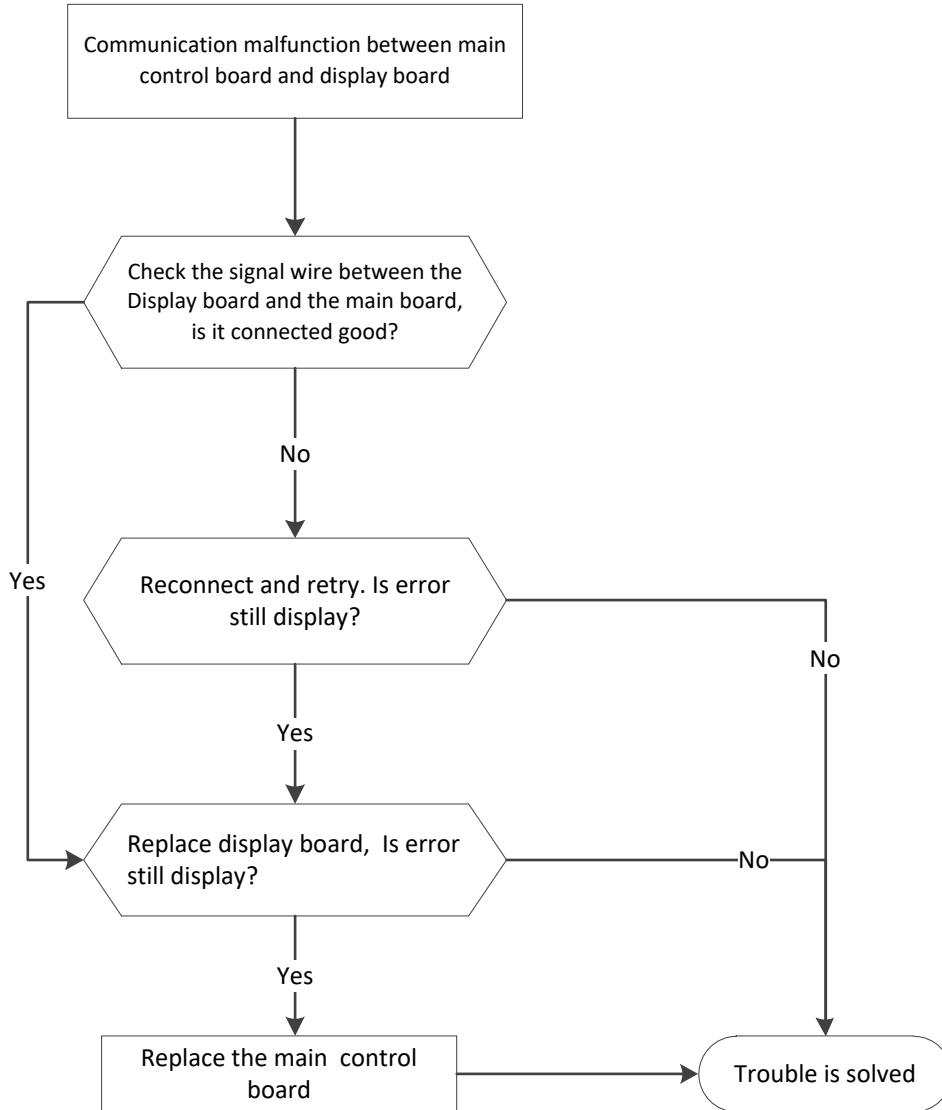

11.2.3 Drive-by-wire controller failure. (LE)

Error Code	LE
Malfunction decision conditions	1, Electric heating signal or compressor signal is on, but fan signal is off 2, Electric heating signal and compressor signal are on, but 4-way valve signal is off
Supposed causes	<ul style="list-style-type: none"> ● Wiring mistake ● Faulty wire controller

Troubleshooting:

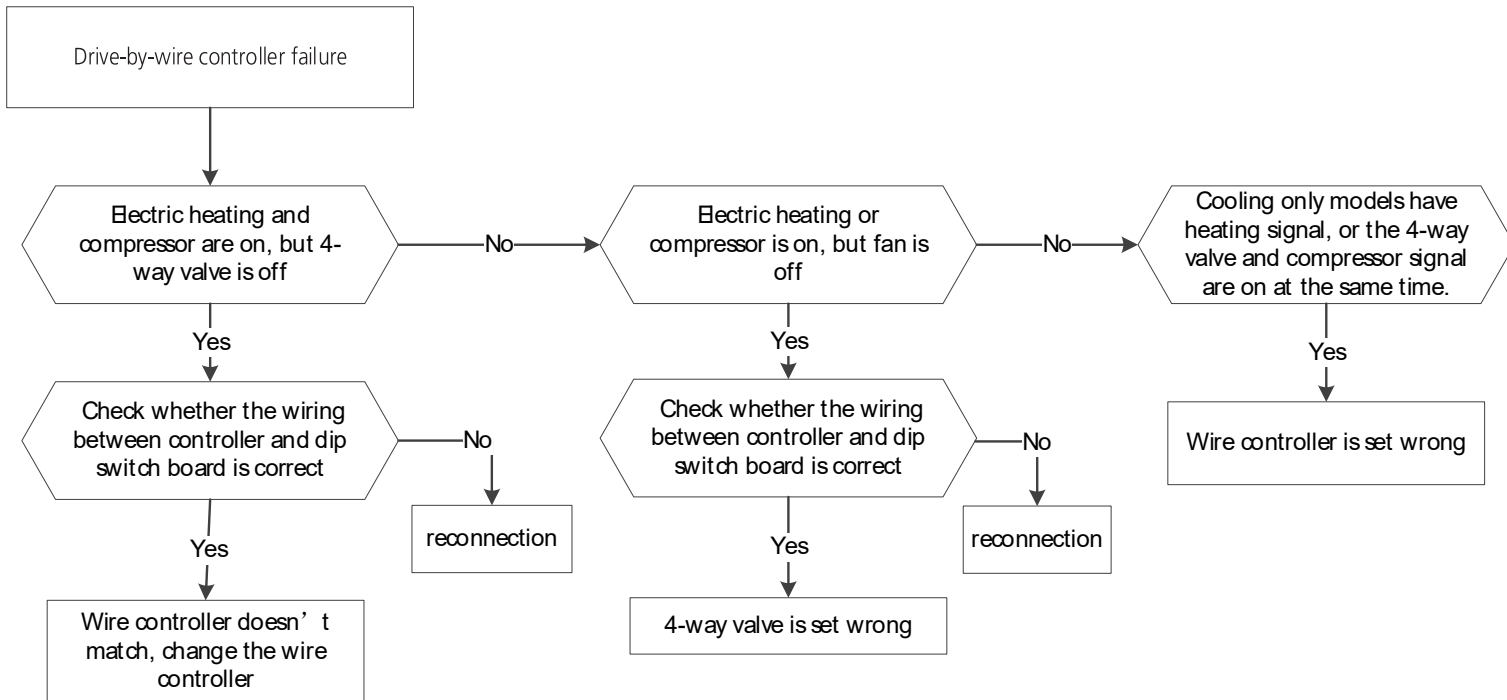

DIP SWITCH TERMINAL	DESIGNATION	24V CONTROLLER
FC(L)	Front desk control terminal L	
FC(N)	Front desk control terminal N	
LOW-FAN	Low fan speed	GL
HI-FAN	High fan speed	GH
4-WAY	4-way valve(for heat pump model)	B
HEAT2	Electrical heater 2	W
HEAT1	Electrical heater 1	(W)
COMP	Compressor	Y
24V(N)	24VAC terminal N COM	C
24V(L)	24VAC terminal L	R

11.2.4 EEPROM parameter error. (E0)

Error Code	E0
Malfunction decision conditions	PCB main chip does not receive feedback from EEPROM chip.
Supposed causes	<ul style="list-style-type: none">● Installation mistake● Faulty PCB

Troubleshooting:

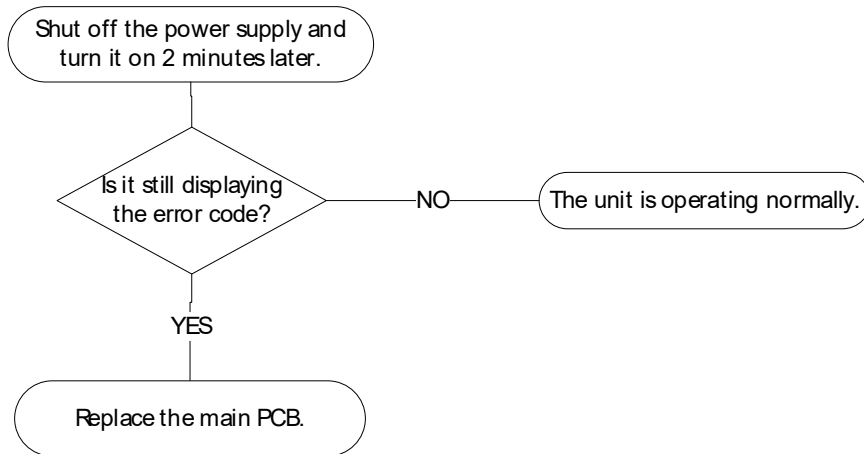

11.2.5 The indoor fan speed is operating outside of the normal range

Error code	E3
Malfunction conditions	When indoor fan speed is too low (80RPM) or too high (2100RPM) for a period of time, the unit ceases operation and the LED displays a failure code.
Potential Causes	<ul style="list-style-type: none"> ● Wiring mistake ● Faulty fan assembly ● Faulty fan motor ● Faulty PCB

Troubleshooting:

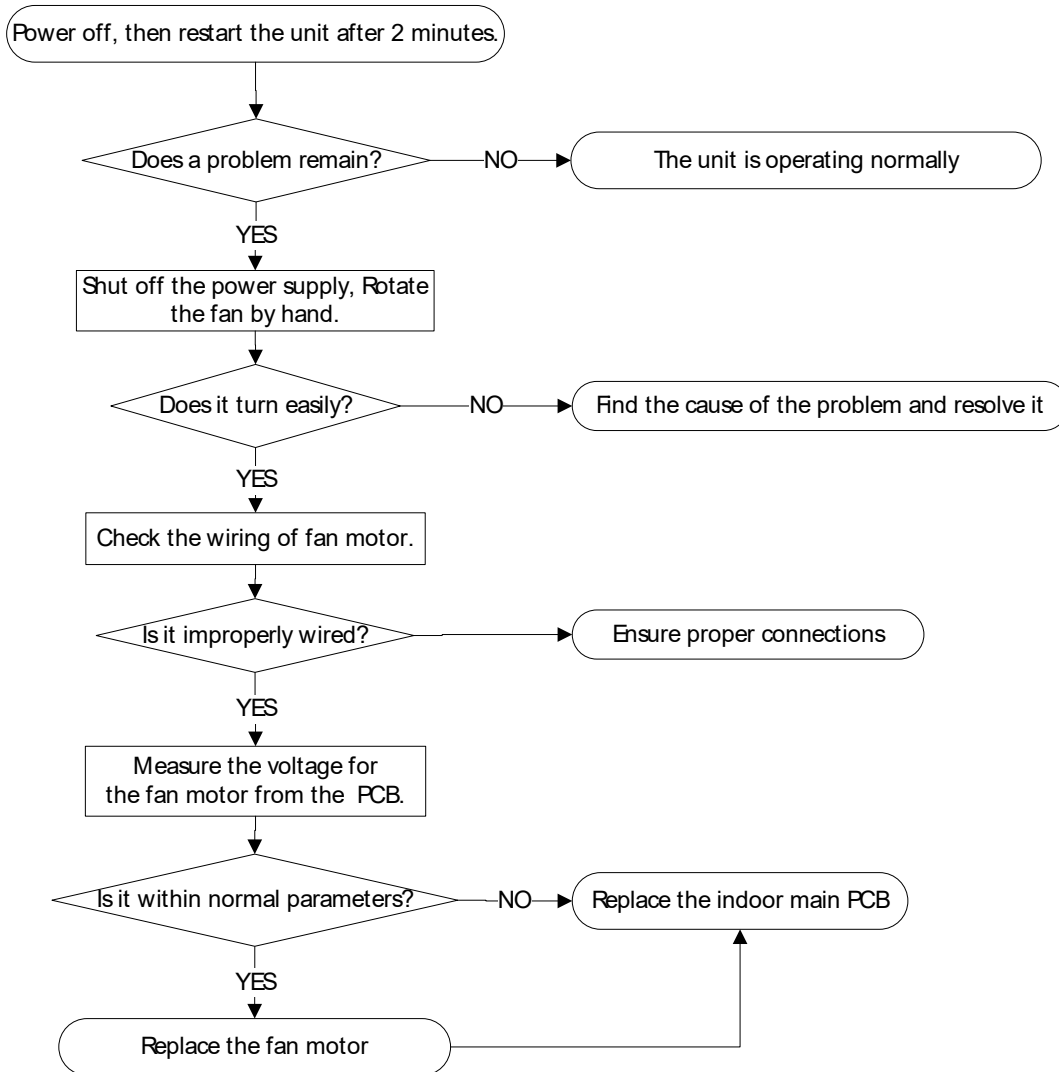

POSSIBLE CAUSES	SOLUTIONS
UNIT DOES NOT START	<p>Unit may have become unplugged. Check that plug is plugged securely in wall receptacle.</p> <p>Note: Plug has a test/reset button on it. Make sure that the plug has not tripped.</p> <p>Fuse may have blown. Replace the fuse. See Note 1.</p> <p>Unit may be off. Reset circuit breaker. See Note 1.</p> <p>Unit may be in a protection mode. Turn unit on (bottom right button on keypad).</p>
UNIT NOT COOLING/HEATING ROOM	<p>Unit air discharge section is blocked. Make sure that curtains, blinds or furniture are not restricting or blocking unit airflow.</p> <p>Temperature setting is not high or low enough. NOTE:Setpoint limits may not allow the unit to heat or cool the room to the temperature desired. Check section on dipswitch settings. Reset to a lower or higher temperature setting.</p> <p>Unit air filters are dirty. Remove and clean filters.</p> <p>Room is excessively hot or cold when unit is started. Allow sufficient amount of time for unit to heat or cool the room.</p> <p>Start heating or cooling early before outdoor temperature, cooking heat or gatherings of people make room uncomfortable.</p> <p>Vent door left open. Close vent door.</p> <p>Unit may be in a protection mode. Check dipswitch and wall thermostat settings for desired comfort.</p> <p>Compressor is in time delay. Wait approximately 3 minutes for compressor to start.</p>
DISPLAY HAS STRANGE NUMBERS/ CHARACTERS ON IT	<p>The unit may be in a protection mode.</p> <p>The unit may be set for °C(instead of °F).</p>
UNIT MAKING NOISES	<p>Clicking, gurgling and whooshing noises are normal during operation of unit.</p>
WATER DRIPPING OUTSIDE	<p>If a drain kit has not been installed, condensation runoff during very hot and humid weather is normal. See Note 2.If a drain kit has been installed and is connected to a drain system, check gaskets and fittings around drain for leaks and plugs.</p>
WATER DRIPPING INSIDE	<p>Wall sleeve must be installed level for proper drainage of condensation .Check that installation is level and make any necessary adjustments.</p>
ICE OR FROST FORMS ON INDOOR COIL	<p>Low outdoor temperature. When outdoor temperature is approximately 55°F or below, frost may form on the indoor coil when unit is in Cooling mode. Switch unit to FAN operation until ice or frost melts.</p>
COMPRESSOR PROTECTION	<p>Power may have cycled, so compressor is in a restart protection.</p> <p>Random Compressor restart - Whenever the unit is plugged in, or power has been restarted, a random compressor restart will occur.</p> <p>After a power outage, the compressor will restart after approximately 3 minutes.</p>
ELECTRIC HEATING FAILURE	<p>Clean the evaporator once every three months by professional people.</p>

NOTES:

- 1.If circuit breaker is tripped or fuse is blown more than once, contact a qualified electrician.
- 2.If unit is installed where condensation drainage could drip in an undesirable location, an accessory drain kit should be installed and connected to drain system.

Characteristic of temperature sensor

Temp.°C/°F	Resistance KΩ	Temp.°C/°F	Resistance KΩ	Temp.°C/°F	Resistance KΩ
-10/14	62.2756	17/62	14.6181	44/111	4.3874
-9 /15.8	58.7079	18/64	13.918	45/113	4.2126
-8 /17.6	56.3694	19/66	13.2631	46/115	4.0459
-7 /19.4	52.2438	20/68	12.6431	47/117	3.8867
-6 /21.2	49.3161	21/70	12.0561	48/118	3.7348
-5 /23	46.5725	22/72	11.5	49/120	3.5896
-4 /24.8	44	23/73	10.9731	50/122	3.451
-3 / 26.6	41.5878	24/75	10.4736	51/124	3.3185
-2 / 28.4	39.8239	25/77	10	52/126	3.1918
-1 /30.2	37.1988	26/79	9.5507	53/127	3.0707
0 /32	35.2024	27/81	9.1245	54/129	2.959
1 /33.8	33.3269	28/82	8.7198	55/131	2.8442
2 /35.6	31.5635	29/84	8.3357	56/133	2.7382
3 /37.4	29.9058	30/86	7.9708	57/135	2.6368
4 /39.2	28.3459	31/88	7.6241	58/136	2.5397
5 /41	26.8778	32/90	7.2946	59/138	2.4468
6 /42.8	25.4954	33/91	6.9814	60/140	2.3577
7 /44.6	24.1932	34/93	6.6835	61/142	2.2725
8 /46.4	22.5662	35/95	6.4002	62/144	2.1907
9 /48.2	21.8094	36/97	6.1306	63/145	2.1124
10 /50	20.7184	37/99	5.8736	64/147	2.0373
11 /51.8	19.6891	38/100	5.6296	65/149	1.9653
12 /53.6	18.7177	39/102	5.3969	66/151	1.8963
13 /55.4	17.8005	40/104	5.1752	67/153	1.830
14 /57.2	16.9341	41/106	4.9639	68/154	1.7665
15 /59	16.1156	42/108	4.7625	69/156	1.7055
16 /60.8	15.3418	43/109	4.5705	70/158	1.6469