



Installation/Owner's Manual



S2 SERIES

BMX922*	9000 BTU 21.5 SEER2 115V Minisplit Heat Pump
BMX1220	12000 BTU 20.8 SEER2 115V Minisplit Heat Pump
BMX922*	9000 BTU 21.7 SEER2 208/230V Minisplit Heat Pump
BMX1221	12000 BTU 21.4 SEER2 208/230V Minisplit Heat Pump
BMX1820	18000 BTU 19.5 SEER2 208/230V Minisplit Heat Pump
BMX2419	24000 BTU 18.5 SEER2 208/230V Minisplit Heat Pump
BMX3020*	30000 BTU 21 SEER2 208/230V Minisplit Heat Pump
BMX3618	36000 BTU 18 SEER2 208/230V Minisplit Heat Pump



* energy star certified



Table of Contents

Specifications Table	1
Packing and Unpacking the Unit	2
Safety Precautions	3
Quick Install Guide	6
Accessories	14
Unit Parts	15
System Installation	16
1. Select installation location	16
2. Removing bracket from unit	17
3. Attach mounting plate to wall	17
4. Drill wall hole for connective piping	19
5. IDU Connect signal and power cables	20
6. Prepare refrigerant piping	22
7. Connect drain hose	23
8. Wrap piping and cables	23
9. Mount indoor unit	25
10. ODU select installation location	26
11. Install drain Joint	27
12. Anchor outdoor unit	27
13. ODU Connect signal and power cables	29
Refrigerant Piping Connection.	32
1. Note on pipe length	32
2. Connection instructions –refrigerant piping	32
3. Cut pipe	32
4. Remove burrs	33
5. Flare pipe ends	33
6. Connect pipes	33
Pressure Test	36
Air Evacuation	37
1. Evacuation instructions	38
2. Note on adding refrigerant	39
Electrical and Gas Leak Checks	40
Test Run	41
Owner's Manual Unit Specifications and Features	42
1. Indoor unit display	42
2. Operating temperature	43
3. Other features	44
4. Setting angle of air flow	45
5. Manual operation (without remote)	45
Care and Maintenance	46
Troubleshooting	48
Remote User Manual	51
1. Remote controller specifications	53
2. Handling the remote controller	54
3. Buttons and functions	55
4. Remote screen indicators	56
5. How to use basic functions	57
6. How to use advanced functions	60

S2 Series Quick Specs



BMX922C	BMY922C
BMX1220C	BMY1221C
BMY1820C	BMY2419C
BMY3020C	BMY36D18C



BMX922WM	BMY922WM
BMX1220WM	BMY1221WM
BMY1820WM	BMY2419WM
BMY3020WM	BMY36D18WM

System	BTUs	Minimum Breaker (Amps)	Maximum Breaker (Amps)	Volts	Ambient Heating (°F)	Ambient Cooling (°F)	Dimensions (ODU) Inches	Weight (ODU) LBS	Dimensions (IDU) Inches	Weight (IDU) LBS	Line Set Size (LL/SL) Inches
BMX922	9000	20	30	115	5~75	5~122	30.12 x 21.85 x 11.93	57.76	28.70 x 11.50 x 7.87	17.64	1/4-3/8
BMX1220	12000	18.5	25	115	5~75	5~122	30.12 x 21.85 x 11.93	62.17	31.57 x 11.61 x 7.87	18.52	1/4-1/2
BMY922	9000	12	15	208-230	5~75	5~122	30.12 x 21.85 x 11.93	55.11	28.70 x 11.50 x 7.87	17.64	1/4-3/8
BMY1221	12000	15	15	208-230	5~75	5~122	30.12 x 21.85 x 11.93	59.30	31.57 x 11.61 x 7.87	18.74	1/4-1/2
BMY1820	18000	15	20	208-230	5~75	5~122	31.69 x 21.81 x 12.99	73.85	38.23 x 12.64 x 8.98	24	1/4-1/2
BMY2419	24000	19	30	208-230	5~75	5~122	35.04 x 26.5 x 13.46	97.88	42.60 x 13.27 x 9.21	29.98	3/8-5/8
BMY3020	30000	23	30	208-230	5~75	5~122	37.24 x 31.89 x 16.14	141.76	49.57 x 14.25 x 11.14	42.99	3/8-5/8
BMY3618	36000	28	35	208-230	5~75	5~122	37.24 x 31.89 x 16.14	150.13	49.57 x 14.25 x 11.14	47.84	3/8-5/8

Packing and Unpacking the Unit

Unpacking the Indoor unit:

1. Cut the sealing tape on the carton with a knife, one cut on the left, one cut in the middle and one cut on the right.
2. Use pliers to take out the sealing nails on the top of the carton.
3. Open the carton.
4. Take out the middle support plate if it's included.
5. Take out the accessory package.
6. Lift the machine out of the carton and lay it flat
7. Remove the left and right packing foam, untie the packaging bag.

Unpacking the outdoor unit:

1. Cut the band.
2. Take the unit out of the carton
3. Remove the foam from around the unit.
4. Remove the packaging bag from the unit.

Packing the indoor unit:

1. Put the indoor unit into the packing bag.
2. Attach the left and right packing foam, and the upper and lower packing foam to the unit.
3. Put the unit in the carton, then include the accessory package in the carton.
4. Close the carton and seal it with tape.

Packing the outdoor unit:

1. Put the outdoor unit into the packaging bag.
2. Put the bottom foam padding into the box.
3. Put the unit in the carton, then add the upper foam to the top of the unit.
4. Close and seal the carton with tape.

NOTE: Please keep all packing items if they may be needed in the future.

Safety Precautions

Read Safety Precautions Before Operation and Installation

Incorrect installation due to ignoring instructions can cause serious damage or injury. The seriousness of potential damage or injuries is classified as either a **WARNING** or **CAUTION**.



WARNING

This symbol indicates the possibility of personnel injury or loss of life.



CAUTION

This symbol indicates the possibility of property damage or serious consequences.



WARNING

This appliance can be used by children aged from 8 years and above and persons with reduced physical, sensory or mental capabilities or lack of experience and knowledge if they have been given supervision or instruction concerning use of the appliance in a safe way and understand the hazards involved. Children shall not play with the appliance. Cleaning and user maintenance shall not be made by children without supervision.

This appliance is not intended for use by persons (including children) with reduced physical, sensory or mental capabilities, or lack of experience and knowledge, unless they have been given supervision or instruction concerning use of the appliance by a person responsible for their safety. Children should be supervised to ensure that they do not play with the appliance.



WARNINGS FOR PRODUCT USE

- If an abnormal situation arises (like a burning smell), immediately turn off the unit and disconnect the power. Call your dealer for instructions to avoid electric shock, fire or injury.
- **Do not** insert fingers, rods or other objects into the air inlet or outlet. This may cause injury, since the fan may be rotating at high speeds.
- **Do not** use flammable sprays such as hair spray, lacquer or paint near the unit. This may cause fire or combustion.
- **Do not** operate the air conditioner in places near or around combustible gases. Emitted gas may collect around the unit and cause explosion.
- **Do not** operate your mini split in a wet room such as a bathroom or laundry room. Too much exposure to water can cause electrical components to short circuit.
- **Do not** expose your body directly to cool air for a prolonged period of time.
- **Do not** allow children to play with the air conditioner. Children must be supervised around the unit at all times.
- If the air conditioner is used together with burners or other heating devices, thoroughly ventilate the room to avoid oxygen deficiency.
- In certain functional environments, such as kitchens, server rooms, etc., the use of specially designed air-conditioning units is highly recommended.

CLEANING AND MAINTENANCE WARNINGS

- Turn off the device and disconnect the power before cleaning. Failure to do so can cause electrical shock.
- **Do not** clean the air conditioner with excessive amounts of water.
- **Do not** clean the air conditioner with combustible cleaning agents. Combustible cleaning agents can cause fire or deformation.

 **CAUTION**

- Turn off the air conditioner and disconnect the power if you are not going to use it for a long time.
- Turn off and unplug the unit during storms.
- Make sure that water condensation can drain unhindered from the unit.
- **Do not** operate the air conditioner with wet hands. This may cause electric shock.
- **Do not** use device for any other purpose than its intended use.
- **Do not** climb onto or place objects on top of the outdoor unit.
- **Do not** allow the air conditioner to operate for long periods of time with doors or windows open, or if the humidity is very high.

 **ELECTRICAL WARNINGS**

- The product must be properly grounded at the time of installation, or electrical shock may occur.
- For all electrical work, follow all local and national wiring standards, regulations, and the Install Manual.
- Connect cables tightly, and clamp them securely to prevent external forces from damaging the terminal. Improper electrical connections can overheat and cause fire, and may also cause shock.
- All electrical connections must be made according to the Electrical Connection Diagram located on the panels of the indoor and outdoor units.
- All wiring must be properly arranged to ensure that the control board cover can close properly. If the control board cover is not closed properly, it can lead to corrosion and cause the connection points on the terminal to heat up, catch fire, or cause electrical shock.
- If connecting power to fixed wiring, an all-pole disconnection device which has at least 3mm clearances in all poles, and have a leakage current that may exceed 10mA, the residual current device(RCD) having a rated residual operating current not exceeding 30mA, and disconnection must be incorporated in the fixed wiring in accordance with the wiring rules.



WARNINGS FOR PRODUCT INSTALLATION

1. Installation must be performed by an authorized dealer or specialist. Defective installation can cause water leakage, electrical shock, or fire.
2. Installation must be performed according to the installation instructions. Improper installation can cause water leakage, electrical shock, or fire. (In North America, installation must be performed in accordance with the requirement of NEC and CEC by authorized personnel only.)
3. Contact an authorized service technician for repair or maintenance of this unit. This appliance shall be installed in accordance with national wiring regulations.
4. Only use the included accessories, parts, and specified parts for installation. Using non-standard parts can cause water leakage, electrical shock, fire, and can cause the unit to fail.
5. Install the unit in a firm location that can support the unit's weight. If the chosen location cannot support the unit's weight, or the installation is not done properly, the unit may drop and cause serious injury and damage.
6. Install drainage piping according to the instructions in this manual. Improper drainage may cause water damage to your home and property.
7. **Do not** install the unit in a location that may be exposed to combustible gas leaks. If combustible gas accumulates around the unit, it may cause fire.
8. Do not turn on the power until all work has been completed.
9. When moving or relocating the air conditioner, consult experienced service technicians for disconnection and reinstallation of the unit.
10. How to install the appliance to its support, please read the information for details in "indoor unit installation" and "outdoor unit installation" sections .

TAKE NOTE OF FUSE SPECIFICATIONS

The air conditioner's circuit board (PCB) is designed with a fuse to provide overcurrent protection. The specifications of the fuse are printed on the circuit board ,such as : T3.15AL/250VAC, T5AL/250VAC, T3.15A/250VAC, T5A/250VAC, T20A/250VAC, T30A/250VAC,etc.

NOTE: For the units with R32 or R290 refrigerant , only the blast-proof ceramic fuse can be used.

Note about Fluorinated Gasses (Not applicable to the unit using R290 Refrigerant)

- **This air-conditioning unit contains fluorinated greenhouse gasses. For specific information on the type of gas and the amount, please refer to the relevant label on the unit itself or the Installation, service, maintenance and repair of this unit must be performed by a certified technician.**
- **Product uninstillation and recycling must be performed by a certified technician.**
- **For equipment that contains fluorinated greenhouse gases in quantities of 5 tonnes of CO₂ equivalent or more, but of less than 50 tonnes of CO₂ equivalent, If the system has a leak-detection system installed, it must be checked for leaks at least every 24 months.**
- **When the unit is checked for leaks, proper record-keeping of all checks is strongly recommended.**

1

Your indoor air handler has been pre-pressurized with nitrogen.

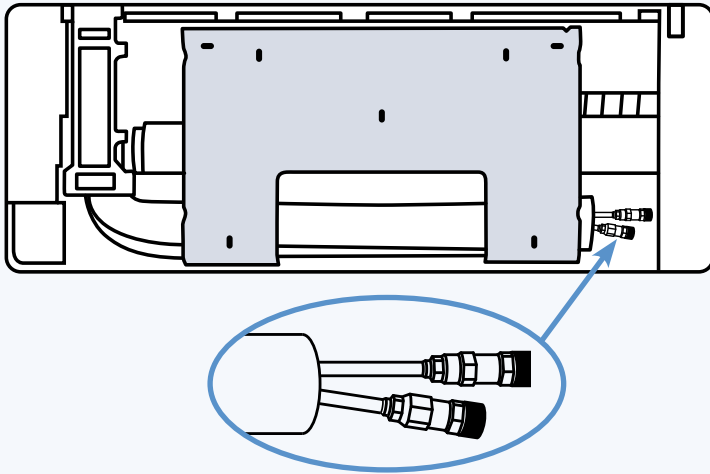

- On the back of the unit, loosen the cap on either of the 2 insulated copper tubes.
- You should hear a hissing noise, which is the release of this harmless gas.
- Allow all of the nitrogen to escape the line, re-tighten the cap, and repeat this process for the other copper tube.

If you don't hear a hissing noise when loosening the cap, please call us at 800.865.5931.

2

Choose the place for the indoor unit on an exterior (outermost) wall.

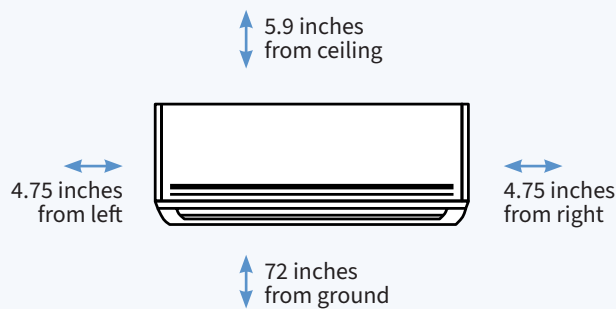

! Maintain listed clearances

If you select not to install the air handler on an exterior wall, please see full owner & install manual.

3

Choose the location to place the outdoor unit.

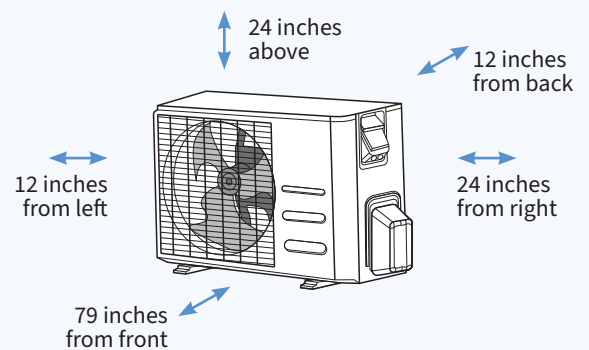

! Maintain listed clearances

0224 QIS101-01



S1 QUICK INSTALL GUIDE

INDOOR UNIT

4

Remove the mounting bracket from the back of the indoor unit and mount it to the wall using the included hardware.

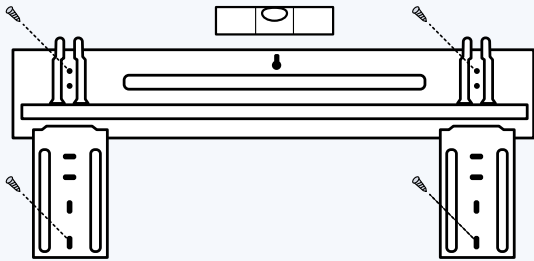

! Bracket must be horizontally level.

5

Mark the position of the large hole for the connecting line set and wires.



By default, the line set will exit the indoor unit on the right side (facing the unit).

If you wish to alter the configuration of the line set, please see full Owner & Install Manual.

6

Drill hole through the wall, maintaining a slight pitch downwards to aid outside drainage.

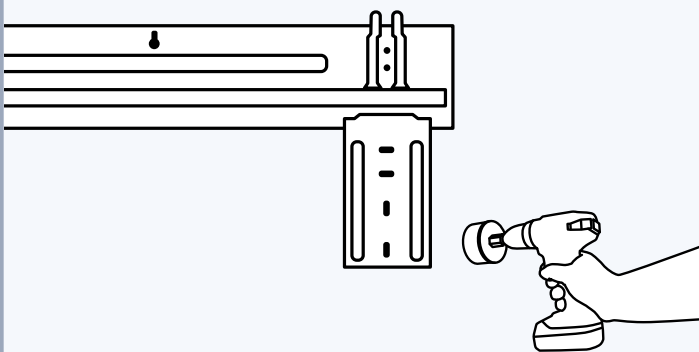

! Hole must be free of electrical wiring, plumbing, or other obstructions.

7

Insert wall sleeve through the wall with the flange facing the exterior.

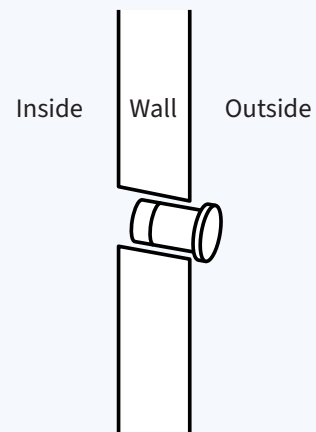

If you can't maintain a downwards pitch, you must install a condensate pump.

0224 QIS101-01



S1 QUICK INSTALL GUIDE

OMS2-01

Page 7

INDOOR UNIT

8

Remove wire cover on front of indoor unit.

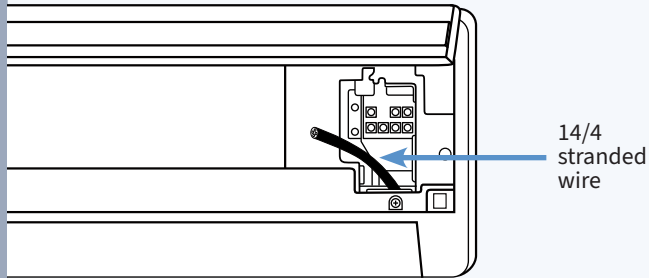

Feed 14/4 stranded wire from the back of the unit to the front.

9

Connect wires to indoor unit.

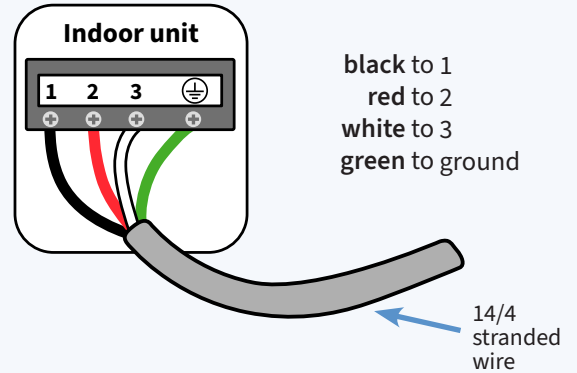

10

Attach the drain hose and prepare the connecting line set, drain, and wires.

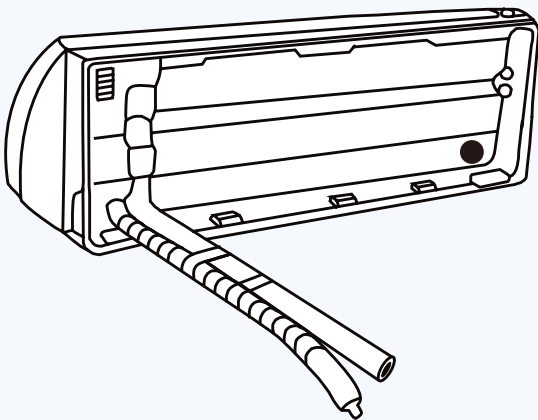

For most installations, the line set will be bent 90° to exit through the wall (as shown above).

11

Bundle the line set, drain, and connection wires together, keeping drain line on bottom.

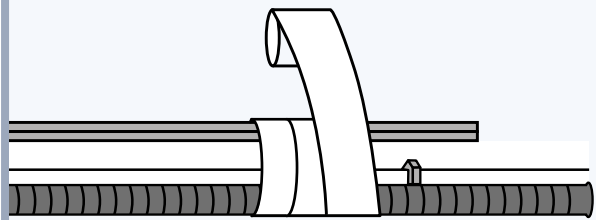

Use PVC electrical tape to secure every 3-4 feet, then install zip ties over taped sections.

! Do not overtighten tape and zip ties, as that will crimp the line set.

The minimum line set is 10 feet. If that length is longer than needed, reposition the outdoor unit or horizontally coil the refrigerant lines after connection.

0224 QIS101-01



S1 QUICK INSTALL GUIDE

OMS2-01

Page 8

INDOOR UNIT

12

Hang the indoor unit on the mounting bracket.

Feed the bundled connection lines through the hole to the outside.

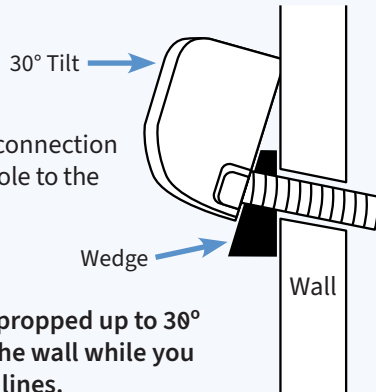

! Unit can be propped up to 30° away from the wall while you manage the lines.

13

Bend the line set on the exterior of the wall towards the outdoor unit.

Run the drain tubing to the ground, at least 12 inches from the structure.

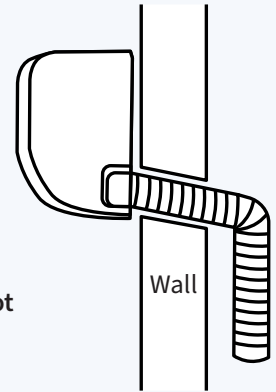

! When bending, do not kink the line set.

With lines larger than 3/8 inch OD, use of a tubing bender is recommended.

OUTDOOR UNIT

14

Mount on a pad, bracket, or stand.

! Position the outdoor unit so it is blowing away from the structure.

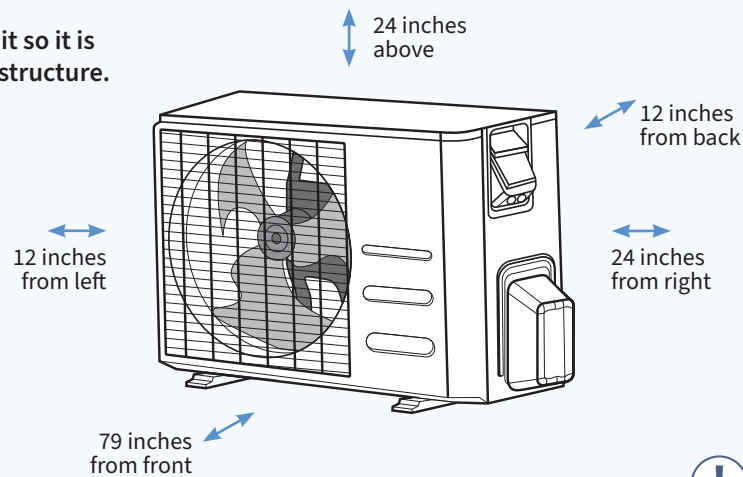

! Maintain listed clearances

0224 QIS101-01



S1 QUICK INSTALL GUIDE

OMS2-01

Page 9

- Any high voltage electrical installation should be performed by an electrician or contractor.
- Make sure the electricity is off.
- Follow all local and national electrical codes.
- Always verify line and load lug locations on the disconnect prior to wiring.
- Wiring shown is based on load, line, line, load.

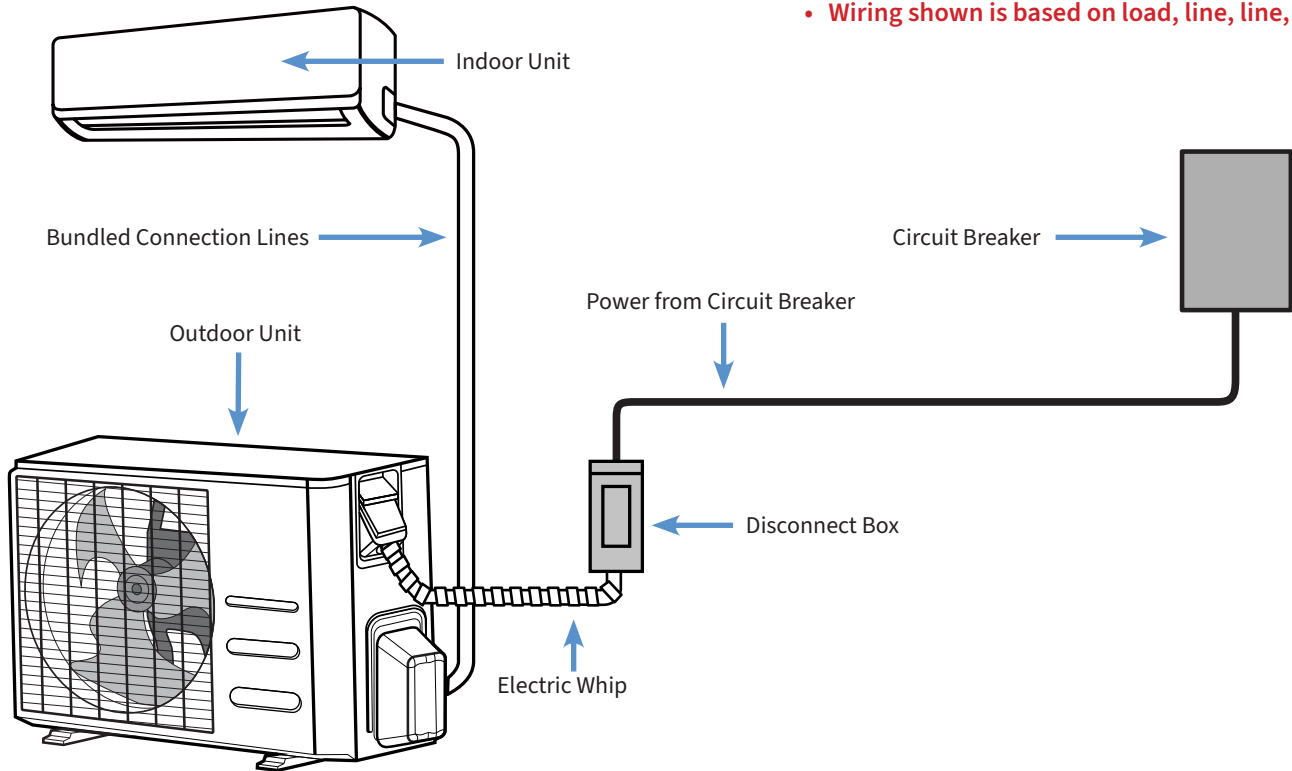

15

Using correct size breaker and wire, run the power to the disconnect box mounted beside the outside unit.

- Connect the indoor unit to the outdoor unit.
- Connect the outdoor unit to the disconnect box with the electrical whip.

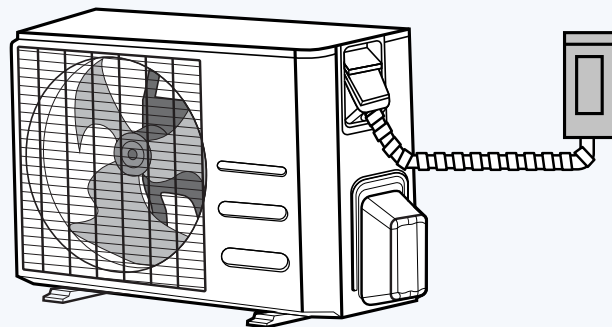

! See next page for wiring diagrams

0224 QIS101-01

FOR 208/240 VOLT SYSTEM

16

Connect indoor unit to the outdoor unit.

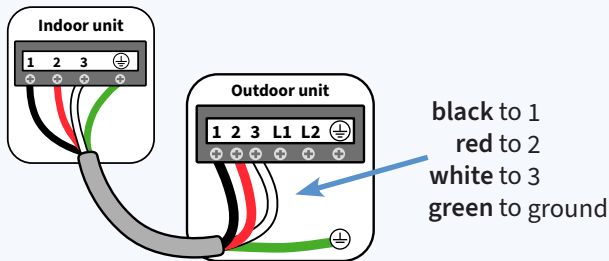

! Wiring shown is based on load, line, line, load.

17

Connect outdoor unit to disconnect box.

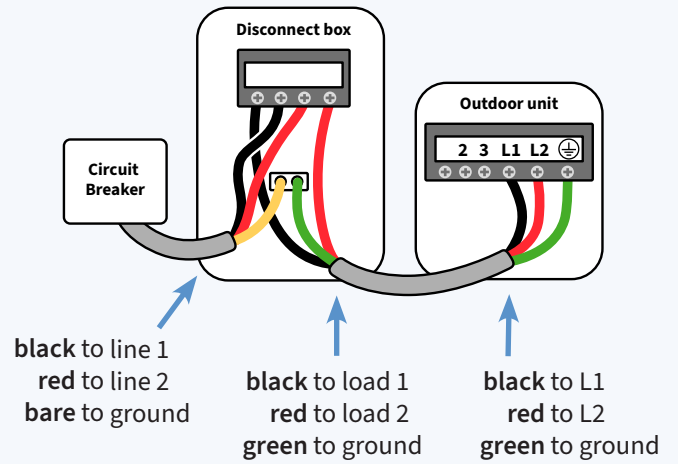

FOR 110/120 VOLT SYSTEM

18

Connect indoor unit to the outdoor unit.

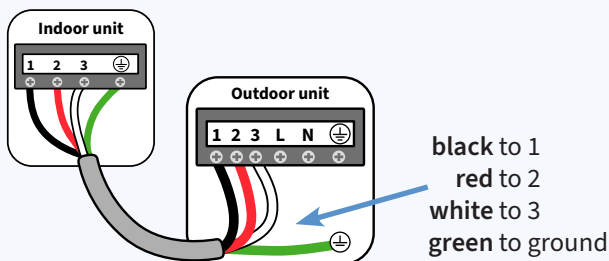

19

Connect outdoor unit to disconnect box.

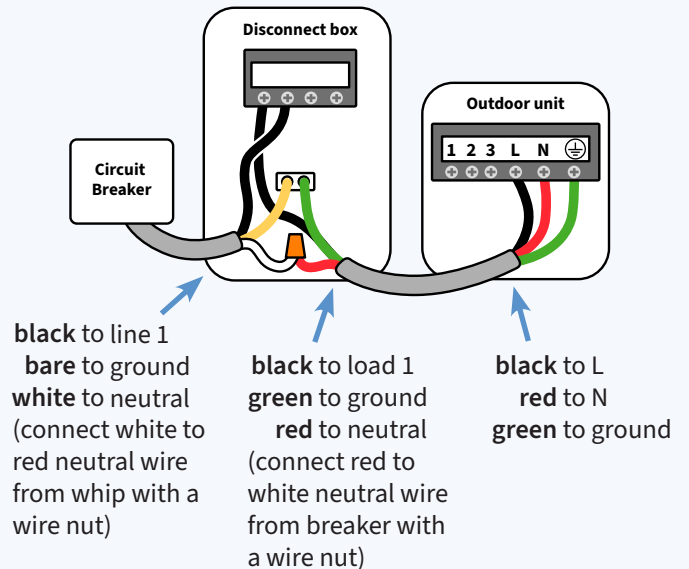

0224 QIS101-01



S1 QUICK INSTALL GUIDE

REFRIGERANT | INDOOR UNIT

20

Remove caps from the line set connections on air handler.

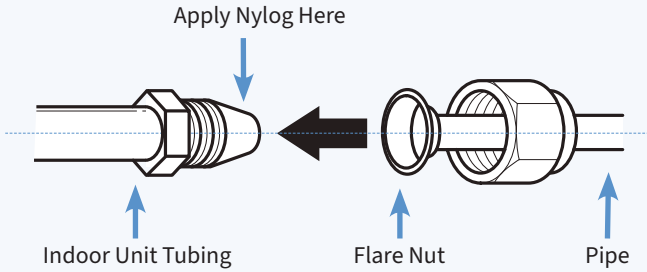

Apply a couple of drops of Nylog sealant to the male side of the flare connection.

Warning: Refrigerant handling should be done by a trained professional.

21

Connect the additional length of line set to the line set on the back of the indoor unit.

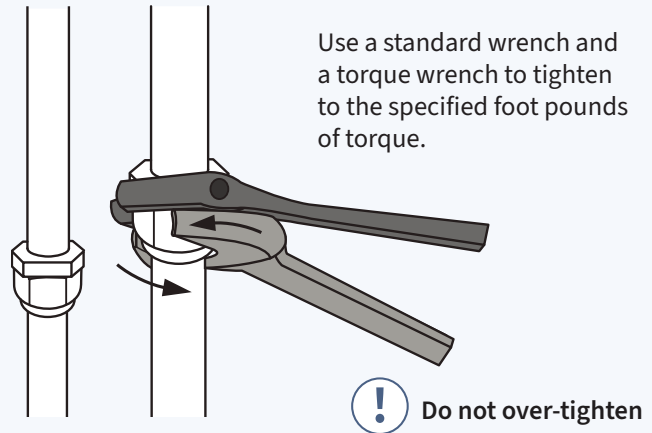

REFRIGERANT | OUTDOOR UNIT

22

Remove caps from the outdoor unit.

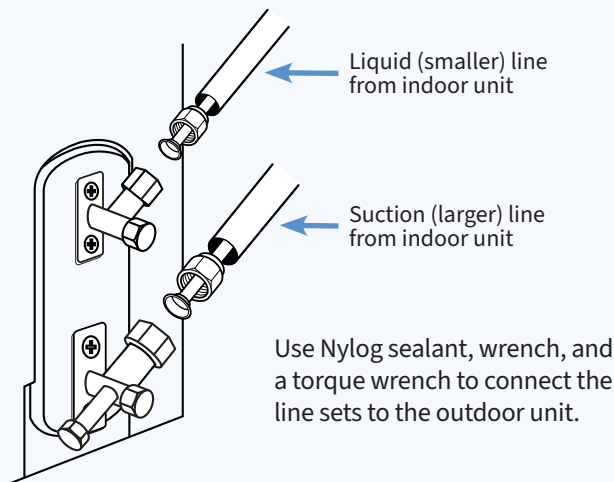

23

Remove cap from the service port on the suction line and perform a pressure test to 300 - 350 psi from the outdoor unit.

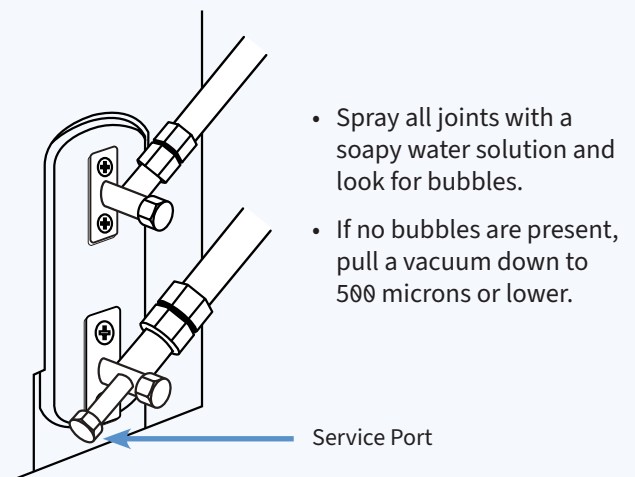

0224 QIS101-01



S1 QUICK INSTALL GUIDE

OMS2-01

Page 12

Warning: Refrigerant handling should be done by a trained professional.

24

After creating the vacuum, close the valves to the vacuum pump.

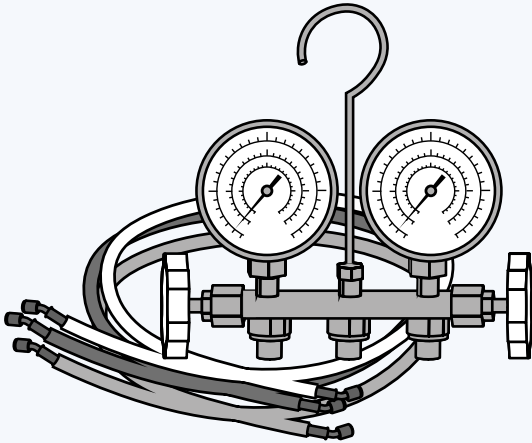

Add refrigerant if the line set used is more than 25 feet in length.

- Add 0.16 oz per foot past 25 if using ¼ inch OD liquid lines (In 0.75, 1.0, and 1.5 ton models)
- Add 0.32 oz per foot past 25 if using ⅜ inch OD liquid lines (In 2.0 ton models)

25

Open horizontal facing valve caps.

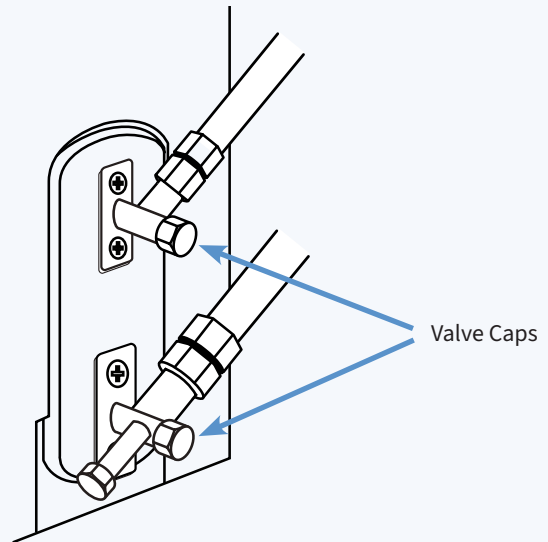

- Use a 5mm allen wrench (hex key) to fully open the lower and then upper valve, releasing the refrigerant into the system.
- Replace caps over open valves.

26

Power up and start the system.

Please call 1.800.865.5931 if you have any questions prior to or during the installation process of your Blueridge Mini-Split System.











Because of the Blueridge promise for continuous product innovation and improvement, some specifications and instructions may change without notification.

0224 QIS101-01

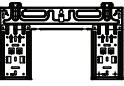

Accessories

The air conditioning system comes with the following accessories. Use all of the installation parts and accessories to install the air conditioner. Improper installation may result in water leakage, electrical shock and fire, or cause the equipment to fail. The items are not included with the air conditioner must be purchased separately.

Name of Accessories	Q'ty(pc)	Shape	Name of Accessories	Q'ty(pc)	Shape
Manual	2~3		Remote controller	1	
Drain joint for outdoor unit	1		Battery	2	
Seal for outdoor unit drain	1		Remote controller holder(optional)	1	
Mounting plate	1		Fixing screw for remote controller holder(optional)	2	
Anchor	5~8 (depending on models)		Small Filter (optional odor reducing filter.	1~2 (depending on models)	
Mounting plate fixing screw	5~8 (depending on models)				

Accessories

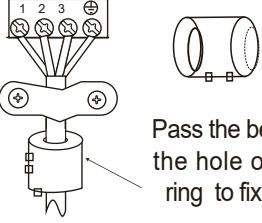
Name	Shape	millimeter(inch)	Quantity(PC)
Connecting pipe assembly	Liquid side	Φ6.35(1/4in)	Parts you must purchase separately. Consult the dealer about the proper pipe size of the unit you purchased.
		Φ9.52(3/8in)	
	Gas side	Φ9.52(3/8in)	
		Φ12.7(1/2in)	
		Φ16(5/8in)	
Φ19(3/4in)			
Magnetic ring and belt (if supplied ,please refer to the wiring diagram to install it on the connective cable.)		Pass the belt through the hole of the Magnetic ring to fix it on the cable	Varies by model

Unit Parts

NOTE: The installation must be performed in accordance with the requirement of local and national standards. The installation may be slightly different in different areas.

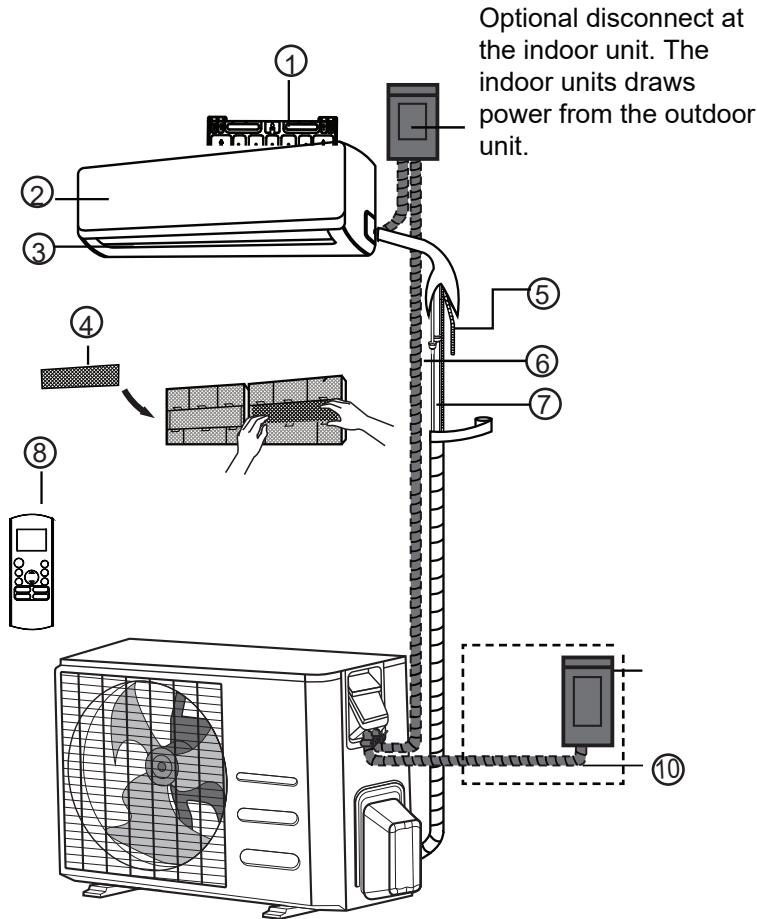

- | | | |
|-----------------------|---|---------------------|
| ① Wall Mounting Plate | ④ Optional Filter (On Back of Main Filter - Some Units) | ⑧ Remote Controller |
| ② Front Panel Power | ⑤ Drainage Pipe | ⑨ Disconnect box |
| ③ Louver | ⑥ 14/4 stranded wire | ⑩ Electrical Whip |
| | ⑦ Refrigerant Piping | |

NOTE ON ILLUSTRATIONS

Illustrations in this manual are for explanatory purposes. The actual shape of your indoor unit may be slightly different.

Indoor Unit Installation

Installation Instructions – Indoor unit

PRIOR TO INSTALLATION

Before installing the indoor unit, refer to the label on the product box to **make sure that the model number of the indoor unit matches the model number of the outdoor unit.**

Step 1 Check the indoor unit: Turn over the indoor unit and loosen (don't remove) one cap on the insulated copper tubes connected to the back of the unit. You should hear a hissing noise. This is nitrogen leaving the indoor unit. This is desired. If you hear no hissing noise please call us at 1800 865 5931. If you hear a hissing noise, hand tighten the cap again and proceed with the installation.



Line set connection cap. Loosen to check for pressure. You should hear a hissing sound

Step 2 Select installation location Before installing the indoor unit, you must choose an appropriate location. The following are standards that will help you choose an appropriate location for the unit.

Proper installation locations meet the following standards:

- Good air circulation
- Convenient drainage
- Noise from the unit will not disturb other people
- Firm and solid—the location will not vibrate
- Strong enough to support the weight of the unit
- A location at least three feet 4 inches from all other electrical devices (e.g., TV, radio, computer)

DO NOT install unit in the following locations:

- Near any source of heat, steam, or combustible gas
- Near flammable items such as curtains or clothing
- Near any obstacle that might block air circulation
- Near the doorway
- In a location subject to direct sunlight

NOTE ABOUT WALL HOLE:

If there is no fixed refrigerant piping:

While choosing a location, be aware that you should leave ample room for a wall hole (see **Drill wall hole for connective piping** step) for the signal cable and refrigerant piping that connect the indoor and outdoor units. The default position for all piping is the right side of the indoor unit (while facing the unit). However, the unit can accommodate piping to both the left and right behind the indoor unit.

Refer to the following diagram to ensure proper distance from walls and ceiling:

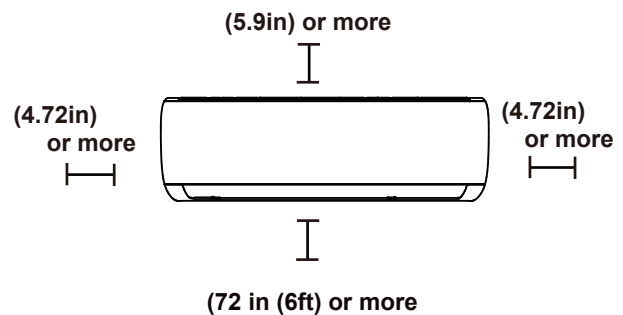

Step 3 Attach mounting plate to wall:

The mounting plate is the device on which you will mount the indoor unit.

- Remove the mounting plate from the back of the indoor unit.

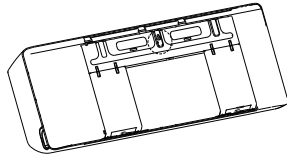

- Secure the mounting plate to the wall with the screws provided. Make sure that mounting plate is flat against the wall.

NOTE FOR CONCRETE OR BRICK WALLS:

If the wall is made of brick, concrete, or similar material, drill 5mm-diameter (0.2in-diameter) holes in the wall and insert the sleeve anchors provided. Then secure the mounting plate to the wall by tightening the screws directly into the clip anchors.

NOTE: When the gas side connective pipe is Φ 16mm (5/8in) or more, the wall hole should be 3-3.5 inches

Wall Mounting Plate Dimensions: (actual bracket shapes may vary from what is shown below)

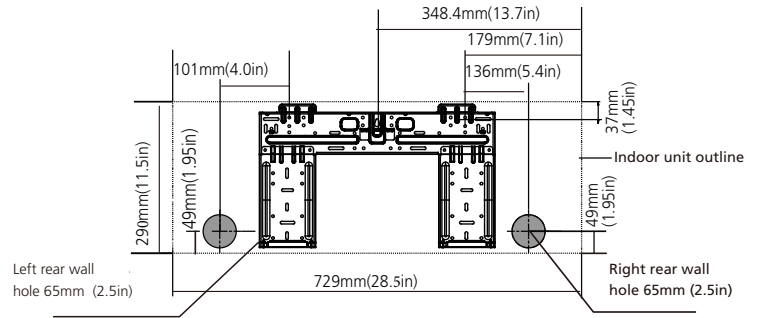

Model A: BMX922WM, BMY922WM, BM09YWM

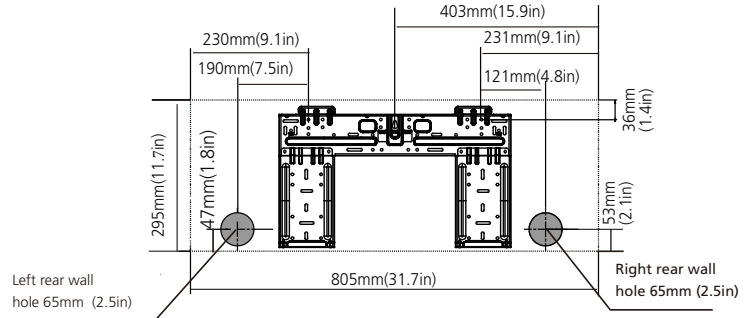

Model B: BMX1220WM, BMY12221WM

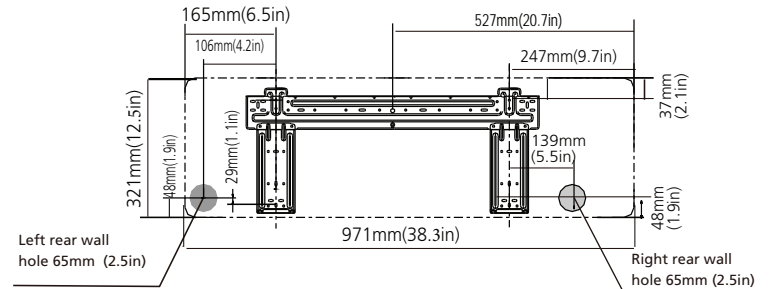

Model D: BMY1820WM

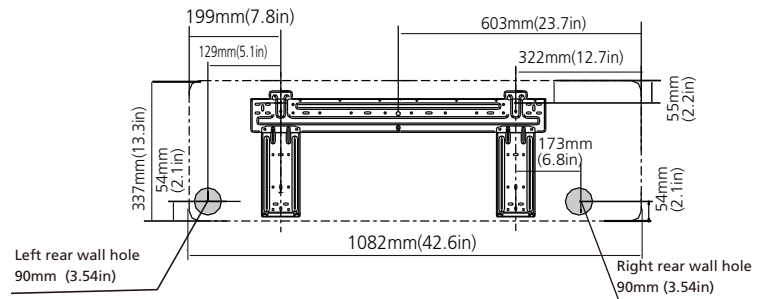

Model E: BMY2419WM

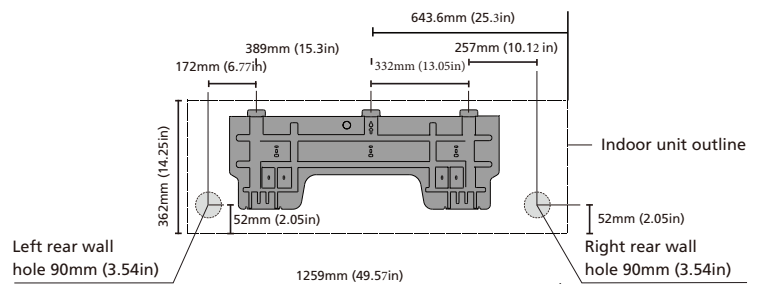

Model F: BMY3618WM, BMY3020WM

Step 4 Determine the hole location: Either lower right or lower left behind the indoor unit. The line set connections are on the back, lower right side of the indoor unit (**looking at** the indoor unit hanging on the wall). Most exterior wall installations will have the hole on the right side.

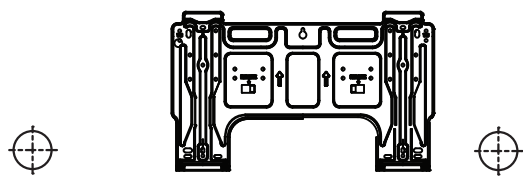

The bottom of the hole should start 1/4 inch above the straight edge

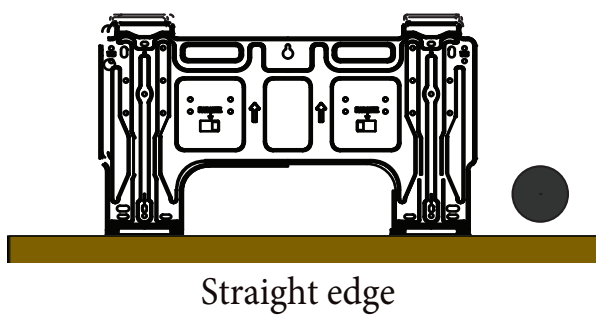

1. Right side hole marking methods:
Find and use the included template.
(refer to the previous page).
2. Hang the indoor unit (as shipped) on the bracket. Mark the right, left, top and bottom of the case using a pencil on the wall.
 - a. Lift the bottom of the air handler up a bit to mark the location on the right hand side where the line set bends to the side behind the indoor unit.
 - b. Mark the center of that bend on the wall. That will be the center of the hole you drill to the outside.
 - c. Remove the indoor unit from the wall. Use a straight edge placed across the bottom arms of the wall bracket. Then find the marked hole location on the wall. Start the bottom of the hole 1/4 above the straight edge.

- d. Measure the marks on the wall to make sure the center of the hole location is accurate.



Line set connection pivot point

If drilling the hole on the left hand side use the included template to mark its location. Keep in mind a tubing bender is recommended for any line set over 3/8 inch and on any left side hole installation.

Note for Interior wall installations

If installing on an interior wall it's recommended to have the line sets come down from the ceiling. Then they will come in on the left side (from the POV of looking at it hanging on the wall) of the indoor unit.

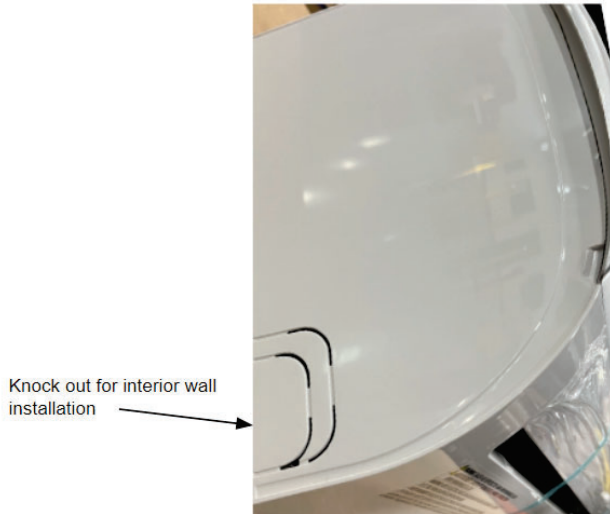

If installing on an interior wall, or if you can't gravity drain the condensation for any reason, then a condensate pump is needed.



Step 5 Drill wall hole for connecting pipes:

After determining the location of the wall hole. Check your wall sleeve diameter. You will drill the hole the same size or 1/8 inch larger than the wall sleeve. Wall sleeves are typically 2.5-3 inches in diameter. Use a 2 1/2 - 3 1/8 inch hole saw and drill a hole in the wall. Make sure the hole is drilled at a slight downwards angle. So the outdoor end of the hole is lower than the indoor end by 2/10 - 3/10 inches. This will help ensure proper water drainage.

⚠ CAUTION

When drilling the wall hole, make sure to avoid wires, plumbing, and other sensitive components.

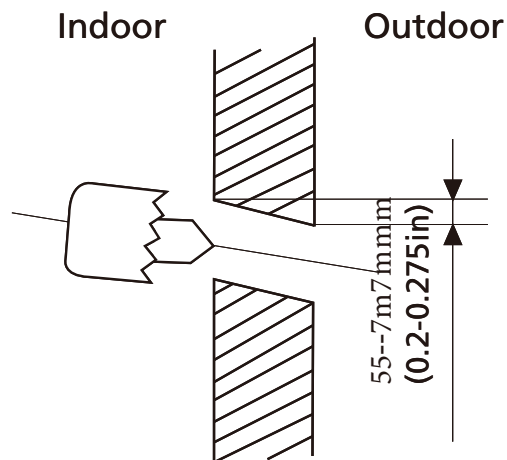

MOUNTING PLATE DIMENSIONS

Different models have different mounting plates. The shape of the mounting plate may be slightly different. But the installation dimensions are the same for the same size of indoor unit.

Correct Orientation of the Mounting Plate

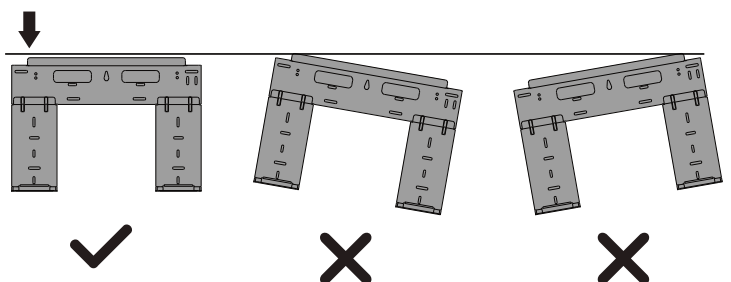

Step 6 Insert the wall sleeve:

Place the protective wall sleeve in the hole. This protects the edges of the hole and will help seal it when you finish the installation process. After drilling the hole, insert the wall sleeve (if used) through the hole with the flange on the exterior wall.

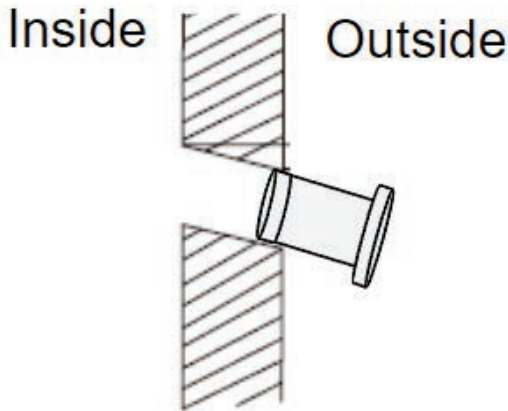

WARNING

BEFORE PERFORMING ANY ELECTRICAL OR WIRING WORK, TURN OFF THE MAIN POWER TO THE SYSTEM.

Step 7 Connect signal and power cables: The signal cable enables communication between the indoor and outdoor units. You must first choose the right cable size before preparing it for connection.

Cable Types

- **Indoor Power Cable** (if applicable):
H05VV-F or H05V2V2-F
- **Outdoor Power Cable:** H07RN-F or H05RN-F •
Signal Cable: H07RN-F

NOTE: In North America, choose the cable type according to the local electrical codes and regulations.

14 gauge 4 conductor, stranded wire is required to connect the indoor and outdoor units. You can't use solid core wire and you can't splice the 14/4 stranded wire as that will cause communication errors between the indoor and outdoor units.



BEFORE PERFORMING ANY ELECTRICAL WORK, READ THESE REGULATIONS

1. All wiring must comply with local and national electrical codes, regulations and must be installed by a licensed electrician.
2. All electrical connections must be made according to the Electrical Connection Diagram located on the panels of the indoor and outdoor units. If there is a serious safety issue with the power supply, stop work immediately. Explain your reasoning to the client, and refuse to install the unit until the safety issue is properly resolved.
3. Power voltage should be within 90-110% of rated voltage. Insufficient power supply can cause malfunction, electrical shock, or fire.
4. If connecting power to fixed wiring, a surge protector and main power switch should be installed.
5. If connecting power to fixed wiring, a switch or circuit breaker that disconnects all poles and has a contact separation of at least 1/8in (3mm) must be incorporated in the fixed wiring. The qualified technician must use an approved circuit breaker or switch.
6. Only connect the unit to an individual branch circuit outlet (breaker).
7. Do not connect another appliance to that outlet. Make sure to properly ground the air conditioner.
8. Every wire must be firmly connected. Loose wiring can cause the terminal to overheat, resulting in product malfunction and possible fire. Do not let wires touch or rest against refrigerant tubing, the compressor, or any moving parts within the unit.
9. To avoid getting an electric shock, never touch the electrical components soon after the power supply has been turned off.
10. After turning off the power, always wait 10 minutes before touching any of the electrical components.

CHOOSE THE RIGHT CABLE SIZE

The size of the power supply cable, signal cable, fuse, and switch needed is determined by the maximum current of the unit. The maximum current is indicated on the nameplate located on the side panel of the unit. Refer to this nameplate to choose the right cable, fuse, or switch.

NOTE: In North America, please choose the right cable size according to the Minimum Circuit Ampacity indicated on the nameplate of the unit.

1. Open front panel of the indoor unit.
2. Using a screwdriver, open the wire box cover on the right side of the unit. This will reveal the terminal block.

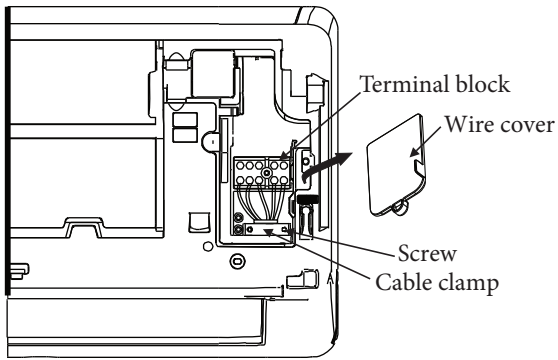

5. Feed the 14/4 wire through the circular opening on the back of the indoor unit on the left hand side by where the line set connects to the indoor unit. Pull the 14/4 stranded wire several inches through the front.

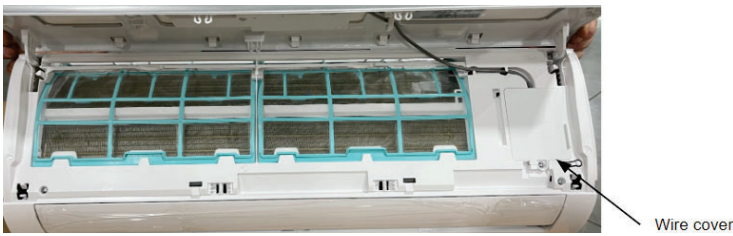

6. Strip back 1/2 inch of insulation on each wire. according to the indoor unit's wiring diagram, connect the u-lug and firmly screw each wire to its corresponding terminal. As follows Connect black to 1, red to 2, white to 3, and green to ground.

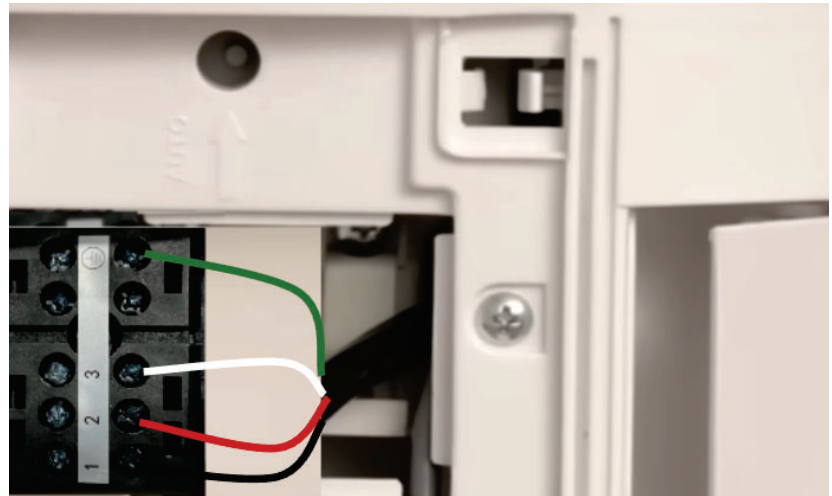

! WARNING

ALL WIRING MUST BE PERFORMED STRICTLY IN ACCORDANCE WITH THE WIRING DIAGRAM LOCATED ON THE BACK OF THE INDOOR UNIT'S FRONT PANEL .

3. Unscrew the cable clamp below the terminal block and set it to the side.



Cable clamp

! CAUTION

DO NOT MIX UP LIVE AND NULL WIRES

This is dangerous, and can cause the air conditioning unit to malfunction.

7. After checking to make sure every connection is secure, use the cable clamp to fasten the signal cable to the unit. Screw the cable clamp down tightly.
8. Replace the wire cover on the front of the unit, and the plastic panel on the back.

4. Facing the back of the unit, remove the plastic panel on the bottom left-hand side.

Step 8 Prepare refrigerant piping:

The refrigerant piping is inside an insulating sleeve attached to the back of the unit. You must prepare the piping before passing it through the hole in the wall.

1. Choose the side that the piping will exit either directly behind the indoor unit or to the left
2. If the wall hole is behind the unit, keep the knock-out panel in place. If the wall hole is to the left side of the indoor unit (looking at the front of the unit), remove the plastic knock-out panel from that side. This will create a slot that the piping can exit the unit. Use needle nose pliers if the plastic panel is too difficult to remove by hand.



3. If existing connective piping is already embedded in the wall, proceed directly to the **Connect Drain Hose** step. If there is no embedded piping, connect the indoor unit's refrigerant piping to the connective piping that will join the indoor and outdoor units. Refer to the **Refrigerant Piping Connection** section of this manual for detailed instructions.

NOTE ON PIPING ANGLE

Refrigerant piping can exit the indoor unit from three different angles: Left-hand side, Left rear, and Right rear. As shown below (back of indoor unit).

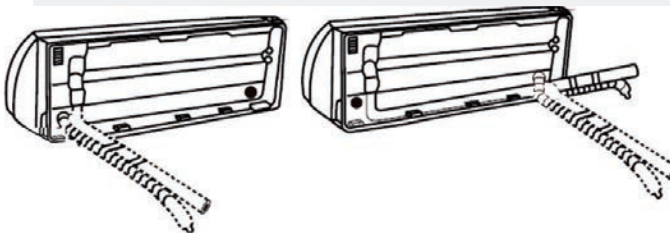

⚠ CAUTION

Be extremely careful not to dent or damage the piping while bending them away from the unit. Any dents in the piping will affect the unit's performance. A tubing bender is recommended for any refrigerant pipes larger than 3/8 inch in diameter.

Left rear (facing the back of the indoor unit): This is the most common installation option for the line sets. If the indoor unit is mounted on an exterior wall you will bend the refrigerant pipes 90 degrees so they are pointing straight out from the back of the unit.

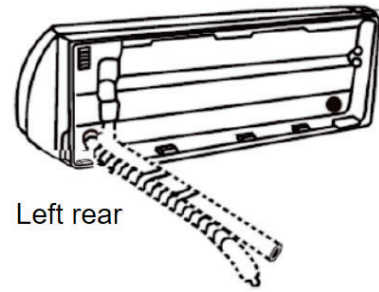

Right rear (facing the back of the indoor unit): A tubing bender is recommended for this less common installation. You will reposition the drain line to exit the right of the indoor unit. It is recommended that you bend the refrigerant lines that will go to the outside in advance of connecting them to the refrigerant pipes on the indoor unit. Then feed the refrigerant pipes through the wall from the inside out.

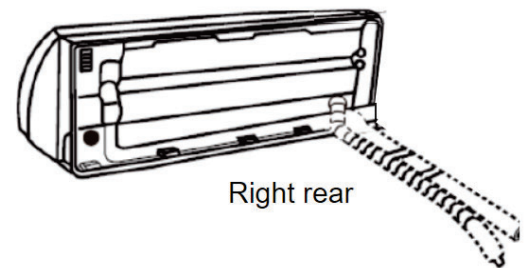

Right side (facing the back of the indoor unit): When installing on an interior wall, or if you want the refrigerant to come in from the right side for any other reason. It is recommended to remove the knock out panel on the right side. Then leave the connected refrigerant piping folded behind the indoor unit as it was shipped. Change the drain connection to the right side (make sure to plug the left side). Then route the line set and drain line accordingly. On interior wall installations a condensate pump is typically needed.

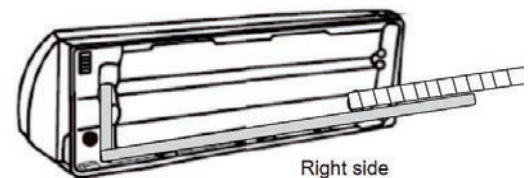

Step 9 Connect drain hose:

By default, the drain hose is attached to the left-hand side of unit (when you're facing the back of the unit). However, it can also be attached to the right-hand side. To ensure proper drainage, attach the drain hose on the same side that your refrigerant piping exits the unit. Attach drain hose extension (purchased separately) to the end of drain hose. The drain line must maintain a downwards pitch away from the air handler and to the exterior or to an interior drain. If you can't maintain a downwards pitch then a condensate pump must be installed.

- Wrap the connection point firmly with Teflon tape to ensure a good seal and to prevent leaks.
- For the portion of the drain hose that will remain indoors, wrap it with foam pipe insulation to prevent condensation.
- Remove the air filter and pour a small amount of water into the drain pan to make sure that water flows from the unit smoothly.
- Secure the drain to the refrigerant lines and 14/4 wire using electrical tape every 3-4 feet.

Wrap Piping and Cables

Before passing the piping, drain hose, and the signal cable through the wall hole, you must bundle them together to save space, protect them, and insulate them (Not applicable in North America).

1. Bundle the drain hose, refrigerant pipes, and 14/4 stranded wire as shown below:

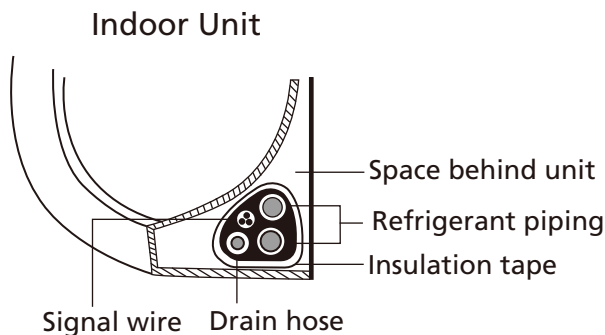

DRAIN HOSE MUST BE ON BOTTOM

Make sure that the drain hose is at the bottom of the bundle. Putting the drain hose at the top of the bundle can cause the drain pan to overflow, which can lead to fire or water damage.

PLUG THE UNUSED DRAIN HOLE

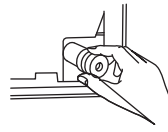

To prevent unwanted leaks you must plug the unused drain hole with the rubber plug provided. Typically factory installed on the right side (facing the back of the unit)

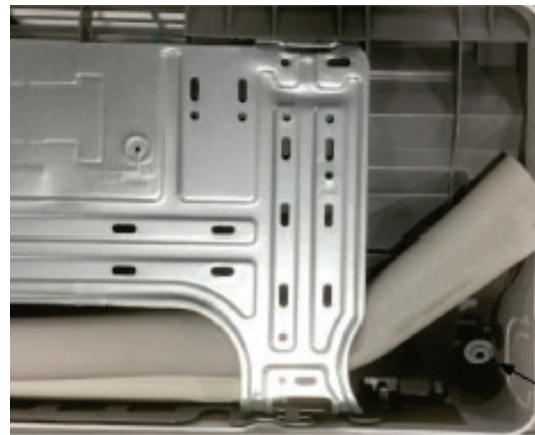

DO NOT INTERTWINE SIGNAL CABLE WITH OTHER WIRES

While bundling these items together, do not intertwine or cross the signal cable with any other wiring.

2. Using adhesive vinyl tape, attach the drain hose to the underside of the refrigerant pipes.
3. Using insulation tape, wrap the 14/4 wire, refrigerant pipes, and drain hose tightly together. Double-check that all items are bundled.

DO NOT WRAP ENDS OF PIPING

When wrapping the bundle, keep the ends of the piping unwrapped. You need to access them to test for leaks at the end of the installation process (refer to **Electrical Checks and Leak Checks** section of this manual).



NOTE ON DRAIN HOSE PLACEMENT

Make sure to arrange the drain hose according to the following figures.

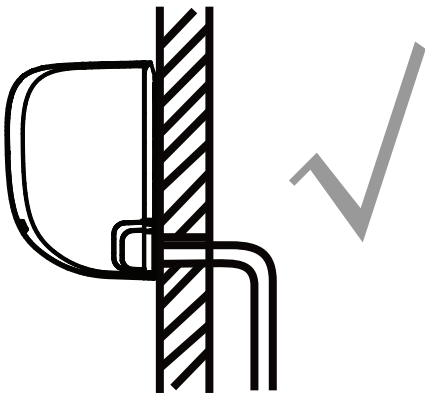

CORRECT

Make sure there are no kinks or dent in drain hose to ensure proper drainage.

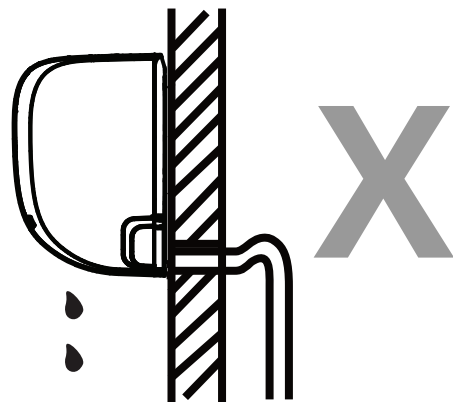

NOT CORRECT

Kinks in the drain hose will create water traps.

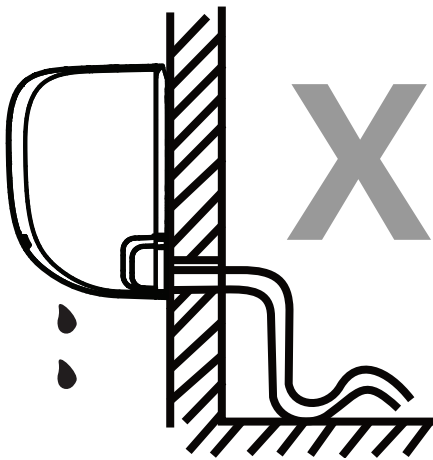

NOT CORRECT

Kinks in the drain hose will create water traps.

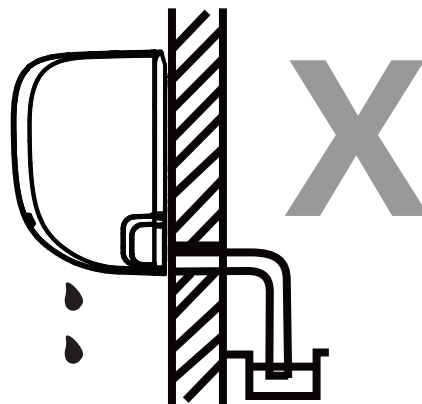

NOT CORRECT

Do not place the end of the drain hose in water or in containers that collect water. This will prevent proper drainage.

Step 10 Mount indoor unit:

If you installed new connective piping to the outdoor unit, do the following:

1. If you have already passed the refrigerant piping through the hole in the wall, proceed to Step 4.
2. Otherwise, double-check that the ends of the refrigerant pipes are sealed to prevent dirt or foreign materials from entering the pipes.
3. Slowly pass the wrapped bundle of refrigerant pipes, drain hose, and 14/4 wire through the hole in the wall.
4. Hook the top of the indoor unit on the upper hook of the mounting plate.
5. Check that unit is hooked firmly on mounting by applying slight pressure to the left and right-hand sides of the unit. The unit should not jiggle or shift.
6. Using even pressure, push down on the bottom half of the unit. Keep pushing down until the unit snaps onto the hooks along the bottom of the mounting plate.
7. Again, check that the unit is firmly mounted by applying slight pressure to the left and the right-hand sides of the unit.

If refrigerant piping is already embedded in the wall, do the following:

1. Hook the top of the indoor unit on the upper hook of the mounting plate.
2. Use a bracket or wedge to prop up the unit, giving you enough room to connect the refrigerant piping, signal cable, and drain hose.

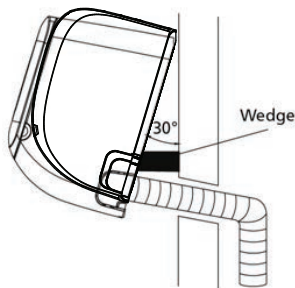

3. Connect drain hose and refrigerant piping (refer to **Refrigerant Piping Connection** section of this manual for instructions).
4. Keep pipe connection point exposed to perform the leak test (refer to **Electrical Checks and Leak Checks** section of this manual).
5. After the leak test, wrap the connection point with insulation tape.
6. Remove the bracket or wedge that is propping up the unit.
7. Using even pressure, push down on the bottom half of the unit. Keep pushing down until the unit snaps onto the hooks along the bottom of the mounting plate.

UNIT IS ADJUSTABLE

Keep in mind that the hooks on the mounting plate are smaller than the holes on the back of the unit. If you find that you don't have ample room to connect embedded pipes to the indoor unit, the unit can be adjusted left or right by about 30-50mm (1.18-1.95in), depending on the model.

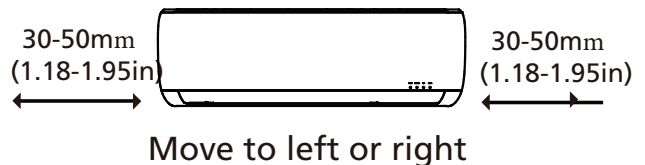

Step 11 Bend the refrigerant pipes:

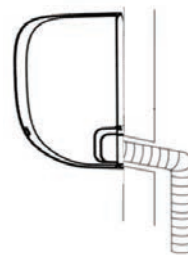

Bend the refrigerant pipes on the exterior of the wall and towards the outdoor unit. Make sure not to kink them. A tubing bender is recommended for refrigerant pipes with larger than 3/8 inch outside diameter. Run the drain tubing to the ground and 12 inches or more from the structure.

Outdoor Unit Installation

Install the unit by following local codes and regulations. They may differ slightly between different regions.

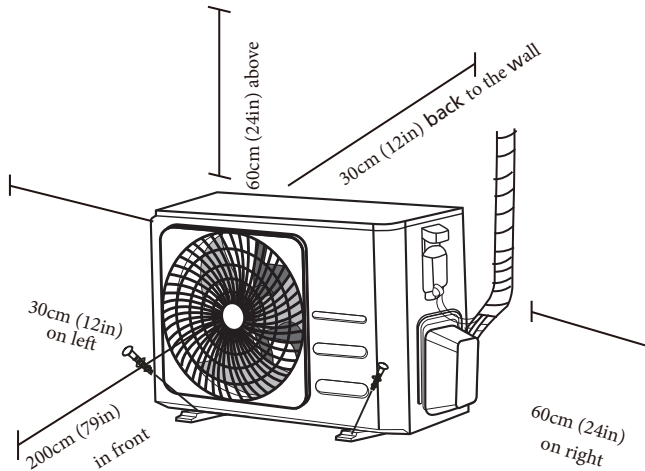

Installation Instructions – Outdoor unit

Step 12 Select installation location and mounting option:

Before installing the outdoor unit, you must choose an appropriate location. The following are standards that will help you choose an appropriate location for the unit.

Proper installation locations meet the following standards:

- Meets all spatial requirements shown in Installation Space Requirements above.
- Good air circulation and ventilation
- Firm and solid—the location can support the unit and not vibrate
- Noise from the unit will not disturb others
- Protected from prolonged periods of direct sunlight or rain
- Where snowfall is anticipated, take appropriate measures to prevent ice buildup and coil damage.

DO NOT install unit in the following locations:

- Near an obstacle that will block air inlets and outlets
- Near a public street, crowded areas, or where noise from the unit will disturb others
- Near animals or plants that will be harmed by hot air discharge
- Near any source of combustible gas
- In a location that is exposed to large amounts of dust
- In a location exposed to an excessive amount of salty air

Determine how you want to install the outdoor unit. Pad, slab stand, bracket, or roof mount (less common). Pick a location for the outdoor unit where you can maintain:

- At least 12 inches of clearance behind the outdoor unit. Raised units on brackets and slab stands can have as little as 8-9 inches of clearance to the back of the outdoor unit to a wall although 12 inches of clearance is preferred.
- 24 inches above and to the side where the refrigerant lines connect
- 12 inches to the opposite side
- Nothing obstructing the direction of air flow in front of the unit for at least 79 inches.
- Mount the outdoor unit to the pad, bracket, or slab stand using appropriately sized nuts and bolts. Make sure to maintain the proper clearances.
- Reducing the clearance may negatively impact the performance of the system
- In cold climates, it is recommended to elevate the outdoor unit above the expected snow line if the mini split will be used as a heat source

SPECIAL CONSIDERATIONS FOR EXTREME WEATHER

If the unit is exposed to heavy wind:

Install unit so that air outlet fan is at a 90° angle to the direction of the wind. If needed, build a barrier in front of the unit to protect it from extremely heavy winds.

See Figures below.

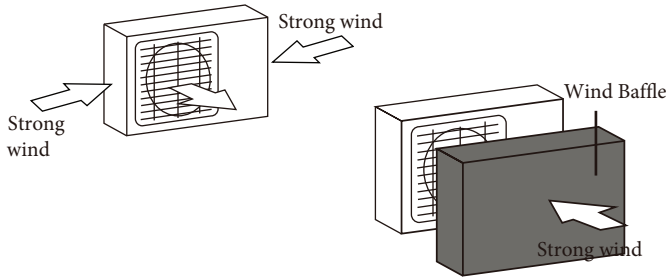

If the unit is frequently exposed to heavy rain or snow:

Build a shelter above the unit to protect it from the rain or snow. Be careful not to obstruct air flow around the unit.

If the unit is frequently exposed to salty air (seaside):

Cleaning the outdoor unit coil 2-4 times a year with low pressure clear water is recommended. (ensure the power is off prior to cleaning)

Install drain joint (Heat pump unit only)

Before bolting the outdoor unit in place, you must install the drain joint at the bottom of the unit. Note that there are two different types of drain joints depending on the type of outdoor unit.

If the drain joint comes with a rubber seal

(see Fig. A), do the following:

1. Fit the rubber seal on the end of the drain joint that will connect to the outdoor unit.
2. Insert the drain joint into the hole in the base pan of the unit.
3. Rotate the drain joint 90° until it clicks in place facing the front of the unit.
4. Connect a drain hose extension (not included) to the drain joint to redirect water from the unit during heating mode.

If the drain joint doesn't come with a rubber seal

(see Fig. B), do the following:

1. Insert the drain joint into the hole in the base pan of the unit. The drain joint will click in place.
2. Connect a drain hose extension (not included) to the drain joint to redirect water from the unit during heating mode.

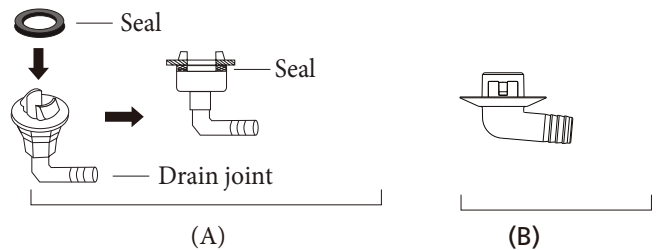
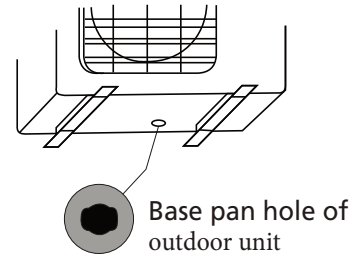

! IN COLD CLIMATES

In cold climates, make sure that the drain hose is as vertical as possible to ensure swift water drainage. If water drains too slowly, it can freeze in the hose and flood the unit. It is recommended to elevate the outdoor unit in cold climates to keep it above the estimated snow line and so the unit can freely drain the condensation produced in heating mode.

Anchor outdoor unit

The outdoor unit can be anchored to the ground or to a wall-mounted bracket with bolt(M10). Prepare the installation base of the unit according to the dimensions below.

UNIT MOUNTING DIMENSIONS

The following is a list of different outdoor unit sizes and the distance between their mounting feet. Prepare the installation base of the unit according to the dimensions below.

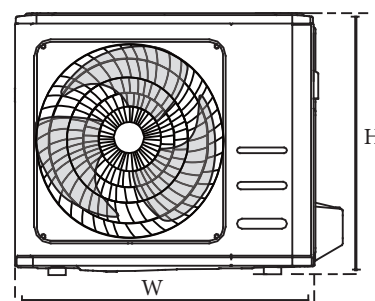
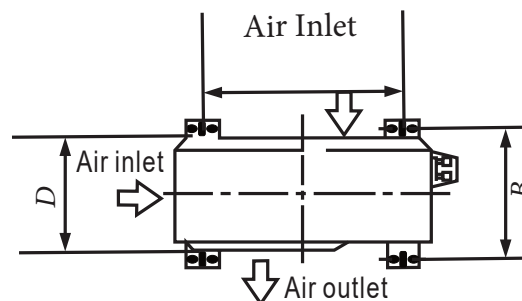

Outdoor Unit Dimensions inches W x H x D	Mounting Dimensions	
	Distance A (inches)	Distance B (inches)
26.8"x 17.1"x 11.2"	18.1"	11.5"
27.5"x 21.6"x 10.6"	17.7"	10.2"
27.5"x 21.6"x 10.8"	17.7"	10.2"
28.3"x 19.5"x 10.6"	17.8"	10.0"
28.7"x 21.8"x 11.8"	17.8"	11.9"
30.1"x 21.8"x 11.9"	17.8"	11.3"
30.3"x 21.8"x 11.8"	19.2"	11.7"
31.7"x 21.8"x 12.9"	20.1"	12.5"
31.5"x 21.8"x 13.1"	20.2"	13.4"
33.3"x 27.6"x 14.3"	21.3"	13.8"
35.0"x 26.5"x 13.5"	26.1"	13.9"
37.2"x 31.9"x 16.5"	26.5"	15.9"
37.2"x 31.9"x 16.1"	26.5"	15.9"

If you will install the unit on the ground or on a concrete mounting platform, do the following:

1. Mark the positions for four expansion bolts based on dimensions chart.
2. Pre-drill holes for expansion bolts.
3. Place a nut on the end of each expansion bolt.
4. Hammer expansion bolts into the pre-drilled holes.
5. Remove the nuts from expansion bolts, and place outdoor unit on bolts.
6. Put washer on each expansion bolt, then replace the nuts.
7. Using a wrench, tighten each nut until snug.

⚠ WARNING

WHEN DRILLING INTO CONCRETE, EYE PROTECTION IS RECOMMENDED AT ALL TIMES

If you will install the unit on a wall-mounted bracket, do the following:

⚠ CAUTION

Make sure that the wall is made of solid brick, concrete, or of similarly strong material. **The wall must be able to support at least four times the weight of the unit.**

1. Mark the position of bracket holes based on dimensions chart.
2. Pre-drill the holes for the expansion bolts.
3. Place a washer and nut on the end of each expansion bolt.
4. Thread expansion bolts through holes in mounting brackets, put mounting brackets in position, and hammer expansion bolts into the wall.
5. Check that the mounting brackets are level.
6. Carefully lift unit and place its mounting feet on brackets.
7. Bolt the unit firmly to the brackets.
8. If allowed, install the unit with rubber gaskets to reduce vibrations and noise.

Steps 13, 14 & 15 Connect signal and power cables:

The outside unit's terminal block is protected by an electrical wiring cover on the side of the unit. A comprehensive wiring diagram is printed on the inside of the wiring.



WARNING

BEFORE PERFORMING ANY ELECTRICAL OR WIRING WORK, TURN OFF THE MAIN POWER TO THE SYSTEM.

1. Prepare the cable for connection:

USE THE RIGHT CABLE

Please choose the right cable refer to "Cable types" in page 22.

CHOOSE THE RIGHT CABLE SIZE

The size of the power supply cable, signal cable, fuse, and switch needed is determined by the maximum current of the unit. The maximum current is indicated on the nameplate located on the side panel of the unit.

NOTE: In North America, please choose the right cable size according to the **Minimum Circuit Ampacity** indicated on the nameplate of the unit.

- Using wire strippers, strip the rubber jacket from both ends of cable to reveal about 40mm (1.57in) of the wires inside.
- Strip the insulation from the ends of the wires.
- Using a wire crimper, crimp u-lugs on the ends of the wires.

PAY ATTENTION TO LIVE WIRE

While crimping wires, make sure you clearly distinguish the Live ("L") Wire from other wires.



WARNING

ALL WIRING WORK MUST BE PERFORMED STRICTLY IN ACCORDANCE WITH THE WIRING DIAGRAM LOCATED INSIDE OF WIRE COVER OF THE OUTDOOR UNIT .

- Unscrew the electrical wiring cover and remove it.
- Unscrew the cable clamp below the terminal block and place it to the side.
- Connect the wire according to the wiring diagram, and firmly screw the u-lug of each wire to its corresponding terminal.
- After checking to make sure every connection is secure, loop the wires around to prevent rain water from flowing into the terminal.
- Using the cable clamp, fasten the cable to the unit. Screw the cable clamp down tightly.

OMS2-01

7. Insulate unused wires with PVC electrical tape.

Arrange them so that they do not touch any electrical or metal parts.

8. Replace the wire cover on the side of the unit, and screw it in place.

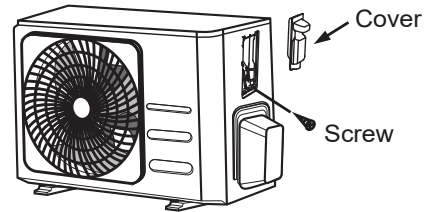

NOTE: If the cable clamp looks like the following, please select the appropriate through-hole according to the diameter of the wire.

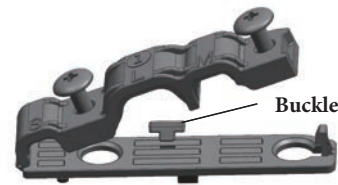

Three size hole: Small, Large, Medium

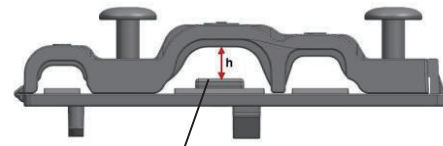

When the cable is not fastened enough, use the buckle to prop it up, so it can be clamped tightly.

In North America

- Remove the wire cover from the unit by loosening the 3 screws.
- Dismount caps on the conduit panel.
- Temporarily mount the conduit tubes (not included) on the conduit panel.
- Properly connect both the power supply and low voltage lines to the corresponding terminals on the terminal block.
- Ground the unit in accordance with local codes.
- Be sure to size each wire allowing several inches longer than the required length for wiring.
- Use lock nuts to secure the conduit tubes.

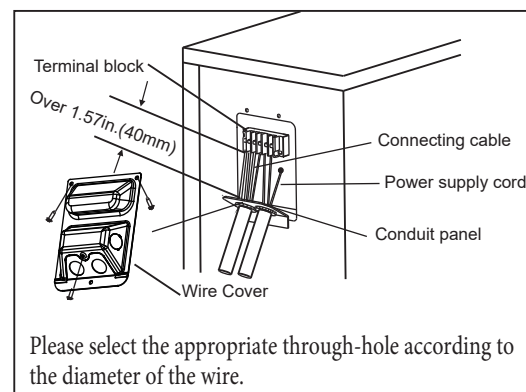

Using a correctly sized breaker and wire (sourced locally) run the power to an electric disconnect box mounted outside by the outdoor unit. Follow all local and national electrical codes. **220 volt systems** use 3 wires for power (hot, hot, ground). The 2 hot wires are connected to the 2 line lugs in the disconnect box the bare wire goes to a ground lug. ALWAYS VERIFY THE LINE AND LOAD LUG LOCATIONS ON DISCONNECT BOX PRIOR TO WIRING.

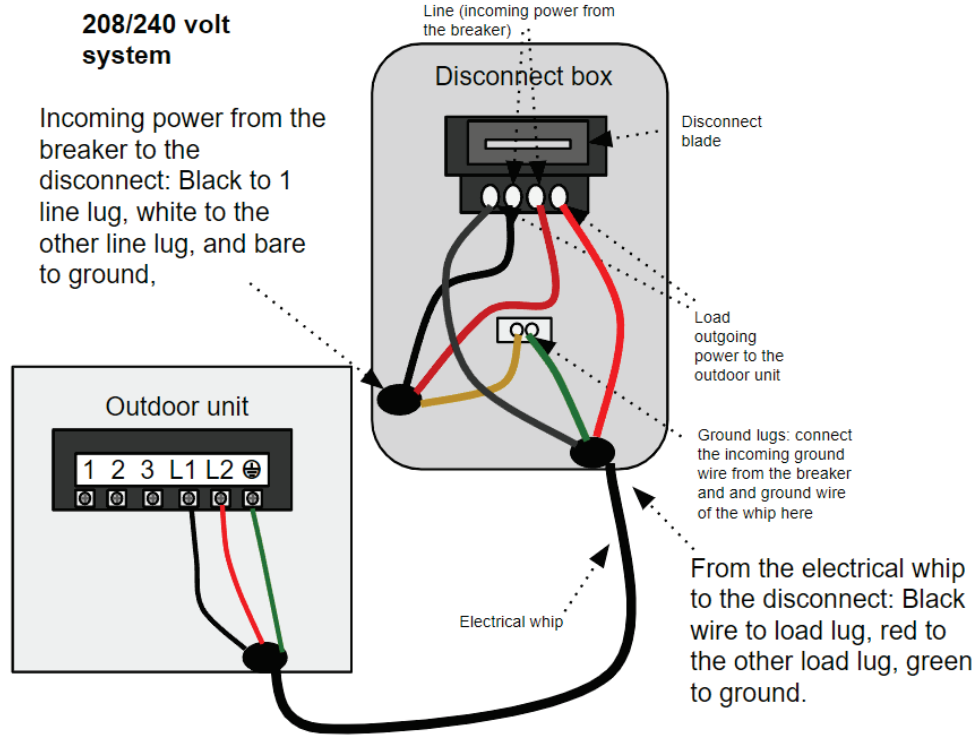

110 volt systems connect the hot wire and neutral wires to the line lugs on the disconnect and connect the ground wire to the ground lug. Connect the electrical whip to the disconnect: 110 volt systems connect the black wire to the hot load lug, connect the red wire to the neutral load lug and the green wire to the ground lug. ALWAYS VERIFY THE LINE AND LOAD LUG LOCATIONS ON DISCONNECT BOX PRIOR TO WIRING.

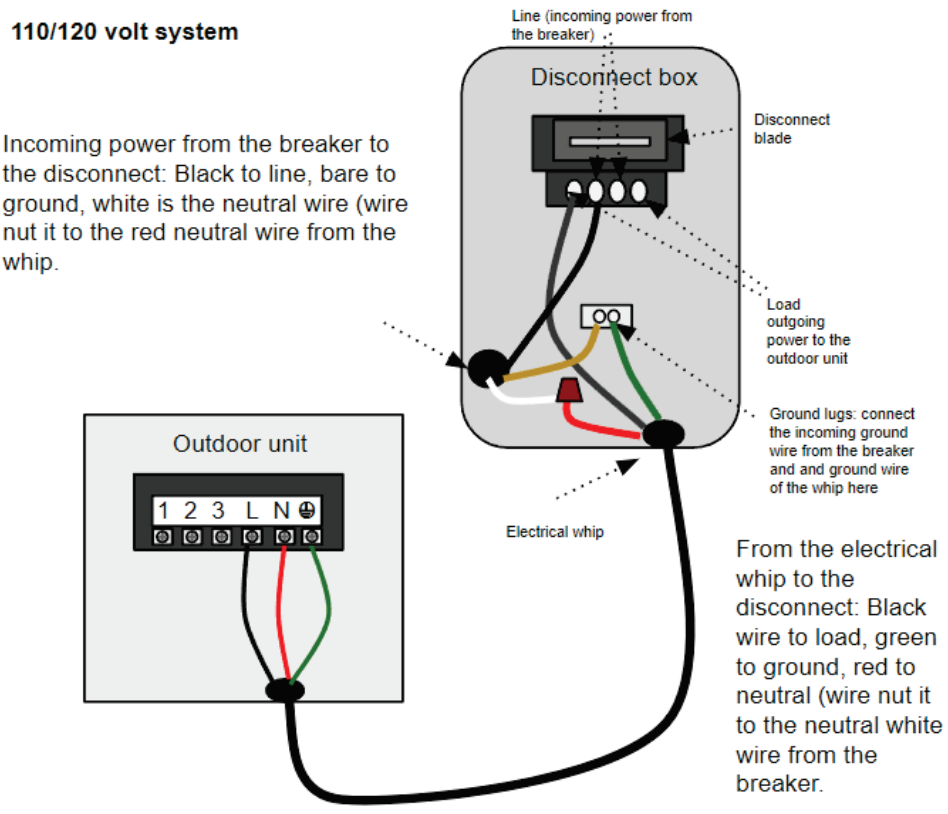

14/4 and line voltage connections at the outdoor unit of a **208/240 volt system**. 14/4 connections black to 1, red to 2, white to 3, green to a ground screw. Line voltage connections black to L1, red L2, green to ground.

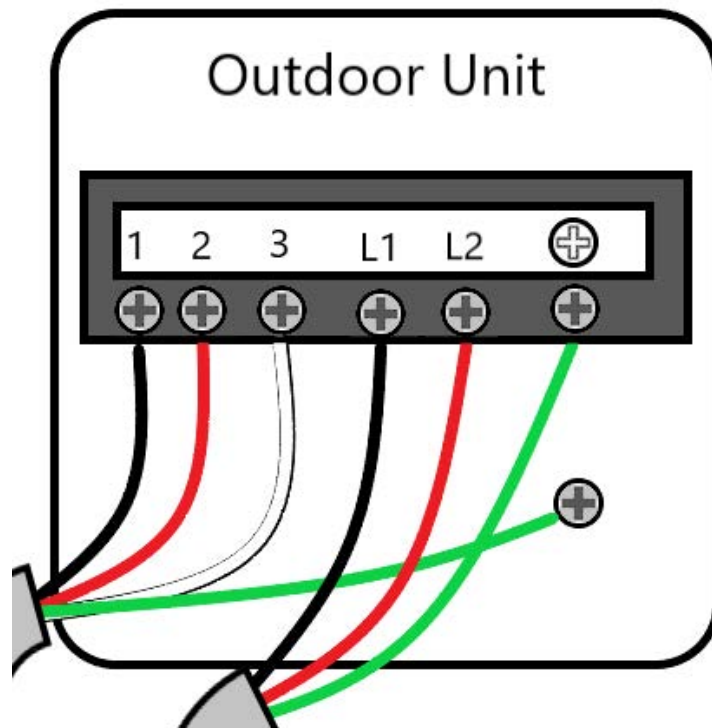

14/4 and line voltage connections at the outdoor unit of a **110/120 volt system**. 14/4 connections black to 1, red to 2, white to 3, green to a ground screw. Line voltage connections black to L1, red N, green to ground.

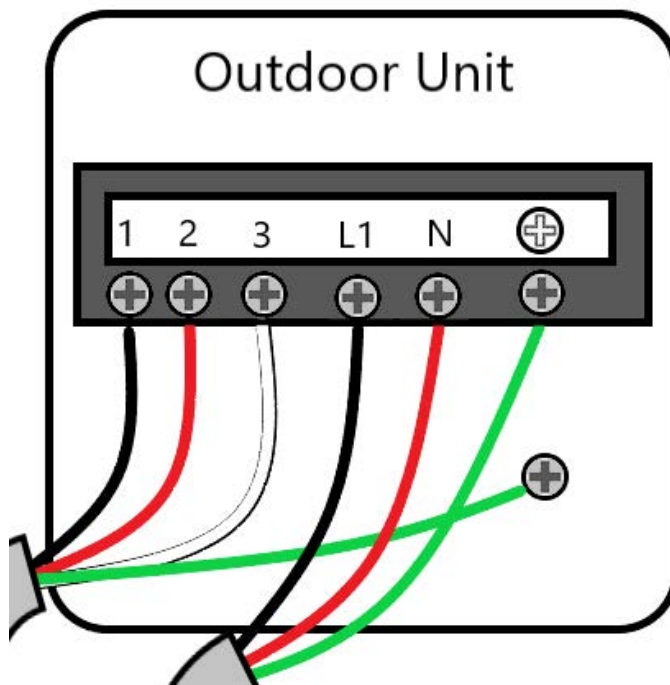

Refrigerant Piping Connection

When connecting refrigerant piping, **do not** let substances or gases other than the specified refrigerant enter the unit. The presence of other gases or substances will lower the unit's capacity, and can cause abnormally high pressure in the refrigeration cycle. This can cause explosion and injury.

Note on Pipe Length

The length of refrigerant piping will affect the performance and energy efficiency of the unit. Nominal efficiency is tested on units with a pipe length of 15.5 feet. In North America, the standard pipe length is 7.5m (25'). A minimum pipe run of 10 feet is required to minimize vibration & excessive noise.

Refer to the table below for specifications on the maximum length and drop height of piping. **Maximum Length and Drop Height of Refrigerant Piping per Unit Model**

Model	Capacity (BTU/h)	Max. Length	Max. Drop Height
R410A,R32 Inverter Split Air Conditioner	< 15,000	82ft	10 (33ft)
	≥ 15,000 and < 24,000	98.5ft	20 (66ft)
	≥ 24,000 and < 36,000	164ft	25 (82ft)

Connection Instructions – Refrigerant Piping

Step 16 Inspect and prepare the refrigerant piping :

If using pre-flared refrigerant lines please inspect the flares on all 4 ends (2 on the liquid line and 2 on the suction line) ensuring that they are smooth and symmetrical. If not please cut and re-flare the lines.

Cut pipes (if needed)

1. When preparing refrigerant pipes, take extra care to cut and flare them properly. This will ensure efficient operation and minimize the need for future maintenance.
2. Measure the distance between the indoor and outdoor units.
3. Using a pipe cutter, cut the pipe a little longer than the measured distance.
4. Make sure the pipe is cut at a perfect degree angle.

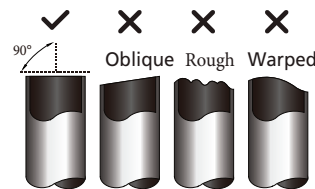

DO NOT DEFORM PIPE WHILE CUTTING

Be extra careful not to damage, dent, or deform the pipe while cutting. This will drastically reduce the heating efficiency of the unit.

Remove burrs if present

Burrs can affect the air-tight seal of refrigerant piping connection. They must be completely removed.

1. Hold the pipe at a downward angle to prevent burrs from falling into the pipe.
2. Using a reamer or deburring tool, remove all burrs from the cut section of the pipe.

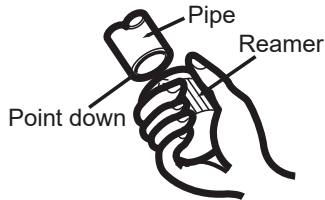

Flare pipe ends

Proper flaring is essential to achieve an airtight seal.

1. After removing burrs from cut pipe, seal the ends with PVC tape to prevent foreign materials from entering the pipe.
2. Sheath the pipe with insulating material.
3. Place flare nuts on both ends of pipe. Make sure they are facing in the right direction, because you can't put them on or change their direction after flaring.

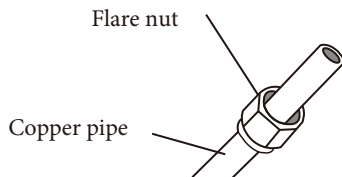

4. Remove PVC tape from ends of pipe when ready to perform flaring work.
5. Clamp flare form on the end of the pipe. The end of the pipe must extend beyond the edge of the flare form in accordance with the dimensions shown in the table below.

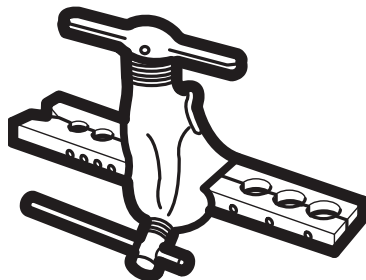

PIPING EXTENSION BEYOND FLARE FORM

Outer Diameter of Pipe (inches)	mm (inches)	
	Min.	Max.
Ø 1/4 (Ø 0.25")	0.7 (0.0275")	1.3 (0.05")
Ø 3/8 (Ø 0.375")	1.0 (0.04")	1.6 (0.063")
Ø 1/2 (Ø 0.5")	1.0 (0.04")	1.8 (0.07")
Ø 5/8 (Ø 0.63")	2.0 (0.078")	2.2 (0.086")
Ø 3/4 (Ø 0.75")	2.0 (0.078")	2.4 (0.094")

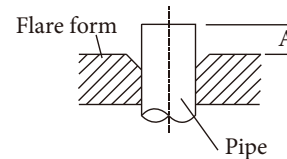

6. Place flaring tool onto the form.
7. Turn the handle of the flaring tool clockwise until the pipe is fully flared.
8. Remove the flaring tool and flare form, then inspect the end of the pipe for cracks and even flaring.

Remove the caps from the line set connections extending from the air handler and remove any plugs/tape from the end of the refrigerant pipes (if present). Connect to the air handler Dry fit (partially thread) the refrigerant lines to the line set connections that extend from the air handler to ensure a proper fit. Once a proper fit is determined disconnect the refrigerant lines and proceed with the installation.

Step 17 Connect pipes:

When connecting refrigerant pipes, be careful not to use excessive torque or to deform the piping in any way. You should first connect the low-pressure (larger) pipe, then the high-pressure (smaller) pipe.

MINIMUM BEND RADIUS

When bending connective refrigerant piping, the minimum bending radius is 4 inches.

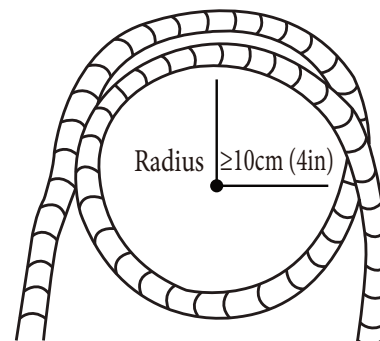

Instructions for Connecting Piping to Indoor Unit

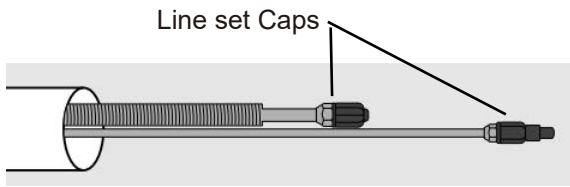

Refrigerant line flared ends

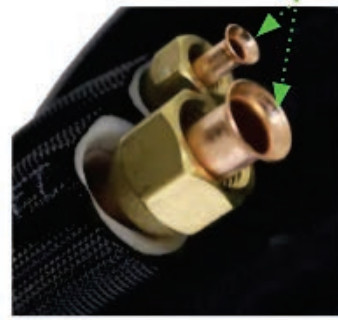

1. Align the center of the two pipes that you will connect. **Please inspect the flares prior** to connecting the line sets. The flares should be smooth and symmetrical. Re-flare the copper tubes if needed to reduce the chance of leaks occurring.

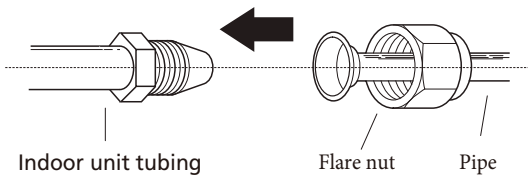

4. While firmly gripping the nut on the unit tubing, use a torque wrench to tighten the flare nut according to the torque values in the Torque Requirements table below. Loosen the flaring nut slightly, then tighten again.

2. (Optional) Put a couple of drops of Nylog on the male threads and a drop on the flared end of the line set and distribute it around the flare.
3. Tighten the flare nut as tightly as possible by hand.
4. Using a spanner, grip the nut on the unit tubing.

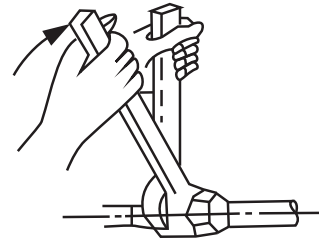

TORQUE REQUIREMENTS

Outer Diameter of Pipe (inches)	Tightening Torque foot pounds	Flare dimension(B) (inches)	Flare shape
Ø 1/4 (0.25)"	13.28 - 14.75	0.33~0.34"	
Ø 3/8 (0.375)"	23.6 - 28.76	0.52~0.53"	
Ø 1/2 (0.5)"	36.14 - 43.51	0.64~0.65"	
Ø 5/8 (0.625)"	42.04 - 52.36	0.76~0.78"	

⚠ DO NOT USE EXCESSIVE TORQUE

Excessive force can break the nut or damage the refrigerant piping. You must not exceed torque requirements shown in the table above.

Step 18 Connect Piping to Outdoor Unit:

1. Unscrew the cover from the packed valve on the side of the outdoor unit.

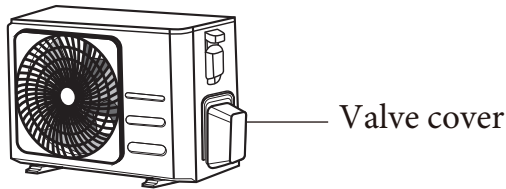

2. Remove protective caps from ends of valves.



3. Dry fit (partially thread) the refrigerant lines to the valves on the outdoor unit to ensure a proper fit. Once a proper fit is determined remove the refrigerant lines from the outdoor valves if using Nylog. If not proceed to step 5.

Refrigerant line flared ends



4. (Optional) Put a couple of drops of Nylog on the male threads and a drop of Nylog on the flared end of the line set and distribute it around the flare.
5. Align the flared pipe end of the refrigerant lines with each valve, and tighten the flare nut as tightly as possible by hand.

! USE SPANNER TO GRIP MAIN BODY OF VALVE

Torque from tightening the flare nut can snap off other parts of valve.

6. Using a spanner(wrench), grip the body of the valve. **Do not grip the nut that seals the service valve (port).**



7. While firmly gripping the body of the valve, use a torque wrench to tighten the flare nut according to the **correct torque values. (previous page). Do not over tighten!**

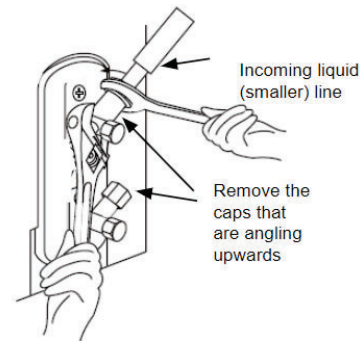

8. Loosen the flaring nut slightly, then tighten again **to the correct torque value.**
9. Repeat Steps 3 to 7 for the remaining pipe.

Step 19 Pressure test with dry nitrogen:

1. Remove the cap on the service (lower) valve pointing downwards (typically) at an angle to expose the service port.



2. Connect 5/16 to 1/4 adapter to the service port.

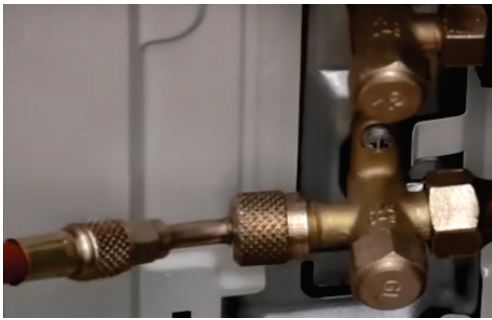

3. Connect the hose of your nitrogen tank and regulator to the 5/16 to 1/4 adapter.

4. Pressurize the system to 300-350 PSI and hold for 15 minutes or more.

5. Use soapy water and spray down all 4 line set connections look for bubbles. Check the pipe connections at both the Indoor and outdoor unit.



6. (If needed) If bubbles are present tighten the connections but not past the maximum torque value. If bubbles are still present stop the flow of nitrogen and check the flares.
7. If no bubbles are present stop the flow of nitrogen and remove the hose from the outdoor unit. Then proceed to Air Evacuation.

Step 20 Air Evacuation:

Preparations and Precautions

Air and foreign matter in the refrigerant circuit can cause abnormal rises in pressure, which can damage the air conditioner, reduce its efficiency, and cause injury. Use a vacuum pump and manifold gauge to evacuate the refrigerant circuit, removing any non-condensable gas and moisture from the system.

Evacuation should be performed upon initial installation and when unit is relocated.

BEFORE PERFORMING EVACUATION

- ☑ Check to make sure the connective pipes between the indoor and outdoor units are connected properly .
- ☑ Check to make sure all wiring is connected properly.

Evacuation Instructions

1. Connect the charge hose of the manifold gauge to service port on the outdoor unit's low pressure valve.

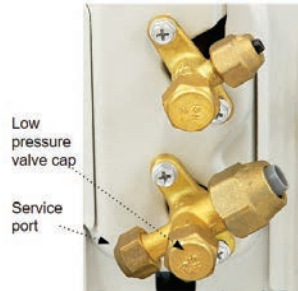

Connect another charge hose from the manifold gauge to the vacuum pump.

3. Open the Low Pressure side of the manifold gauge.
4. Keep the High Pressure side closed. Turn on the vacuum pump to evacuate the system. (if it isn't built into your gauge set the you will need to purchase a separate micron gauge).
5. Run the vacuum for at least 15 minutes, until the Low pressure gauge reads 500 microns or less.

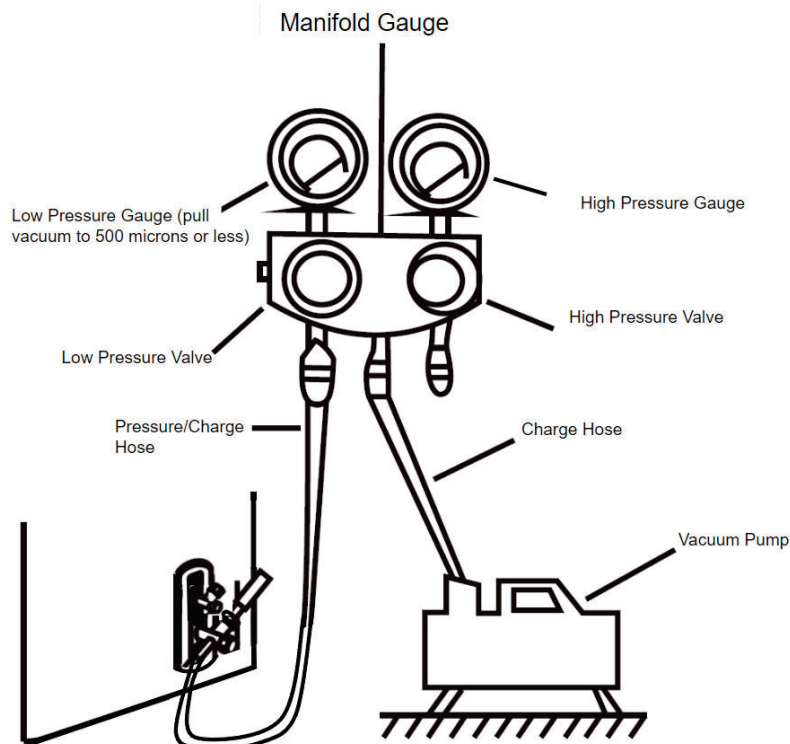

6. Close the Low Pressure valve of the manifold gauge, and turn off the vacuum pump.
7. Wait for at least 15 minutes, then check that there has been no change in system pressure.
8. If there is a change in system pressure, refer to Gas Leak Check section for information on how to check for leaks.

Step 21 Release the refrigerant into the system:

If there is no change in system pressure unscrew the valve cap from the low pressure valve. Insert a 5 millimeter allen wrench (hex key) and open the valve by turning the wrench in a 1/4 counterclockwise turn. Listen for gas to exit the system, then close the valve after 5 seconds.

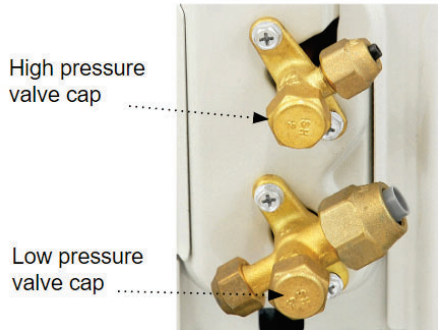

10. Watch the Pressure Gauge for one minute to make sure that there is no change in pressure. The Pressure Gauge should read slightly higher than atmospheric pressure.
11. Remove the charge hose from the service port and unscrew the cap on the low pressure valve.



! OPEN VALVE STEMS GENTLY
 When opening valve stems, turn the hexagonal wrench until it hits against the stopper. Do not try to force the valve to open further.

12. Using hexagonal wrench, fully open both the high pressure and low pressure valves.

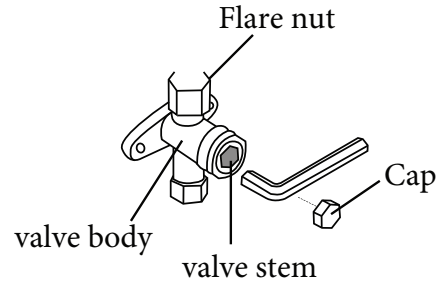

13. Tighten valve caps on all three valves (service port, high pressure, low pressure) by hand. You may tighten it further using a torque wrench if needed.

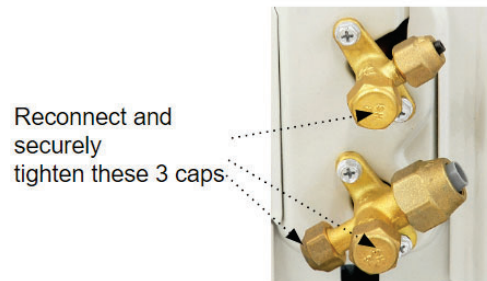

Note on Adding Refrigerant

Some systems require additional charging depending on pipe lengths. The standard pipe length in North America is 25 feet. The refrigerant should be charged from the service port on the outdoor unit's low pressure valve. The additional refrigerant to be charged can be calculated using the following formula:

The minimum line set is 10 feet. If that is more than needed reposition the outdoor unit, or horizontally coil the refrigerant pipes.

ADDITIONAL REFRIGERANT PER PIPE LENGTH

Connective Pipe Length (25 ft)	Air Purging Method	Additional Refrigerant	
≤ Standard pipe length	Vacuum Pump		
> 25 ft	Vacuum Pump	Liquid Side: Ø 1/4 in (ø 0.25 in) R410A: (Pipe length – 25 ft) x 0.16oZ/ft	Liquid Side: Ø 3/8 in (ø 0.375 in) R410A: (Pipe length – 25 ft) x 0.32oZ/ft

 **CAUTION** DO NOT mix refrigerant types.

Electrical and Gas Leak Checks

Before Test Run

Only perform test run after you have completed the following steps:

- **Electrical Safety Checks** – Confirm that the unit's electrical system is safe and operating properly
- **Gas Leak Checks** – Check all flare nut connections and confirm that the system is not leaking
- Confirm that gas and liquid (high and low pressure) valves are fully open

Electrical Safety Checks

After installation, confirm that all electrical wiring is installed in accordance with local and national regulations, and according to the Installation Manual.

BEFORE TEST RUN

Check Grounding Work

Measure grounding resistance by visual detection and with grounding resistance tester. Grounding resistance must be less than 0.1Ω .

Note: This may not be required for some locations in North America.

DURING TEST RUN

Check for Electrical Leakage

During the **Test Run**, use an electroprobe and multimeter to perform a comprehensive electrical leakage test.

If electrical leakage is detected, turn off the unit immediately and call a licensed electrician to find and resolve the cause of the leakage.

Note: This may not be required for some locations in North America.

WARNING – RISK OF ELECTRIC SHOCK

ALL WIRING MUST COMPLY WITH LOCAL AND NATIONAL ELECTRICAL CODES, AND MUST BE INSTALLED BY A LICENSED ELECTRICIAN.

Gas Leak Checks

There are two different methods to check for gas leaks.

Soap and Water Method

Using a soft brush, apply soapy water or liquid detergent to all pipe connection points on the indoor unit and outdoor unit. The presence of bubbles indicates a leak.

Leak Detector Method

If using leak detector, refer to the device's operation manual for proper usage instructions.

AFTER PERFORMING GAS LEAK CHECKS

After confirming that the all pipe connection points DO NOT leak, replace the valve cover on the outside unit.

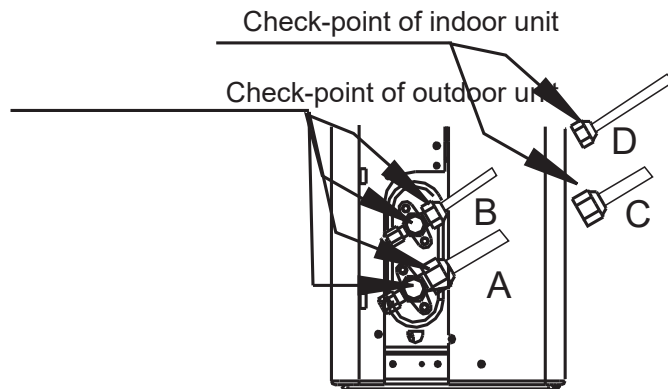

A: Low pressure stop valve
B: High pressure stop valve
C & D: Indoor unit flare nuts

Test Run

Test Run Instructions

You should perform the **Test Run** for at least 30 minutes.

1. Connect power to the unit.
2. Press the **ON/OFF** button on the remote controller to turn it on.
3. Press the **MODE** button to scroll through the following functions, one at a time:
 - **COOL** – Select lowest possible temperature
 - **HEAT** – Select highest possible temperature
4. Let each function run for 5 minutes, and perform the following checks:

List of Checks to Perform	PASS/FAIL	
No electrical leakage		
Unit is properly grounded		
All electrical terminals properly covered		
Indoor and outdoor units are solidly installed		
All pipe connection points do not leak	Outdoor (2):	Indoor (2):
Water drains properly from drain hose		
All piping is properly insulated		
Unit performs COOL function properly		
Unit performs HEAT function properly		
Indoor unit louvers rotate properly		
Indoor unit responds to remote controller		

Test Run

DOUBLE-CHECK PIPE CONNECTIONS

During operation, the pressure of the refrigerant circuit will increase. This may reveal leaks that were not present during your initial leak check. **Take time during the Test Run to double-check that all refrigerant pipe connection points do not have leaks.** Refer to **Gas Leak Check** section for instructions.

5. After the Test Run is successfully completed, and you confirm that all checks points in List of Checks to Perform have PASSED, do the following:
 - a. Using remote control, return unit to normal operating temperature.
 - b. Using insulation tape, wrap the indoor refrigerant pipe connections that you left uncovered during the indoor unit installation process.

IF AMBIENT TEMPERATURE IS BELOW 17° C (62°F)

You can't use the remote controller to turn on the COOL function when the ambient temperature is below 17°C. In this instance, you can use the **MANUAL CONTROL** button to test the COOL function.

1. Lift the front panel of the indoor unit, and raise it until it clicks in place.
2. The **MANUAL CONTROL** button is located on the right-hand side of the unit. Press it 2 times to select the COOL function.
3. Perform Test Run as normal.

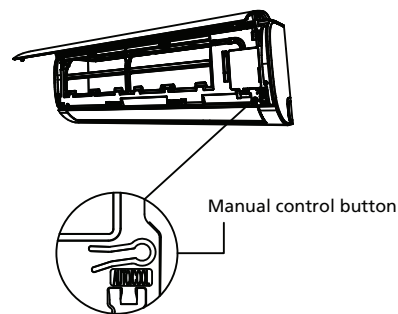

Unit Specifications and Features

Indoor unit display

NOTE: Different models have different front panel and display window. Not all the indicators describing below are available for the air conditioner you purchased. Please check the indoor display window of the unit you purchased.

Illustrations in this manual are for explanatory purposes. The actual shape of your indoor unit may be slightly different. The actual shape shall prevail.

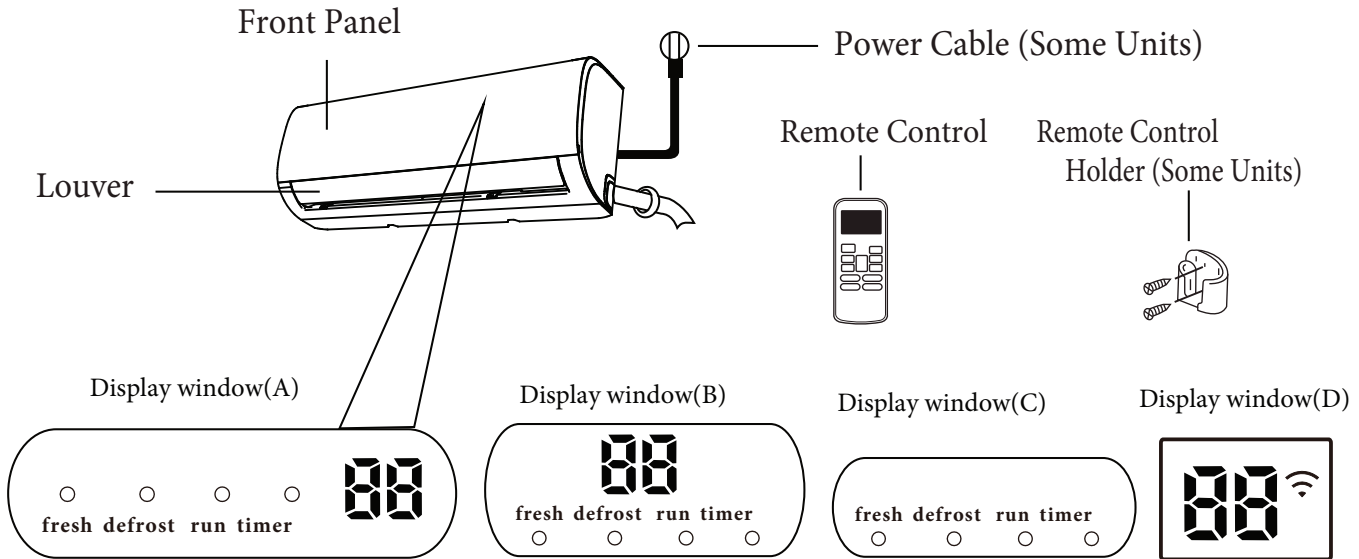

Fresh, Eco, and UV-C lamp functions are not supported modes for this device.

Display Code Meanings

- “fresh” when Fresh and UV-C lamp(if any) feature is activated(some units)
- “defrost” when defrost feature is activated.
- “run” when the unit is on.
- “timer” when TIMER is set.
- “” when Wireless Control feature is activated(some units)
- “” Displays temperature, operation feature and Error codes:
When ECO function(some units) is activated, the ‘’ illuminates gradually one by one as -- -- --set temperature -- in one second interval.
- “” for 3 seconds when:
 - TIMER ON is set (if the unit is OFF, “” remains on when TIMER ON is set)
 - FRESH, UV-C lamp, SWING, TURBO, or SILENCE feature is turned on
- “” for 3 seconds when:
 - TIMER OFF is set
 - FRESH, UV-C lamp, SWING, TURBO, or SILENCE feature is turned off
- “” when anti-cold air feature is turned on
- “” when defrosting(cooling & heating units)
- “” when unit is self-cleaning(some units)
- “” when 8°C heating feature is turned on(some units)

Operating temperature

When your air conditioner is used outside of the following temperature ranges, certain safety protection features may activate and cause the unit to disable.

Inverter system indoor and outdoor temp ranges

	COOL mode	HEAT mode	DRY mode
Room Temperature (Remote control) Range	(62°F - 86°F)	(62°F - 86°F)	(50°F - 86°F)
Outdoor Temperature	(5°F - 122°F)	(5°F - 75°F)	(32°F - 122°F)

NOTE: Room relative humidity less than 80%. If the air conditioner operates in excess of this figure, the surface of the air conditioner may attract condensation. Please sets the vertical air flow louver to its maximum angle (vertically to the floor), and set HIGH fan mode.

To further optimize the performance of your unit, do the following:

- Keep doors and windows closed.
- Limit energy usage by using TIMER ON and TIMER OFF functions.
- Do not block air inlets or outlets.
- Regularly inspect and clean air filters.

Other Features

- **Auto-Restart**

If the unit loses power, it will automatically restart with the prior settings once power has been restored.

- **Self Clean**

- If you press “Self Clean” when the unit is in cooling or drying mode:
- The indoor unit will run in fan-only mode, then low heat, and finally in fan only mode.
- Self Clean keeps the indoor unit dry and prevents mold growth.

- **Wifi Control** (accessory required)

Wireless control allows you to control your system using you mobile device.

For the USB device access, replacement, maintenance operations must be carried out by professional staff.

- **Louver Angle Memory**

When turning on your unit, the louver will automatically resume its former angle

- **Refrigerant Leakage Detection**

The indoor unit will automatically display “EL0C” or flash LEDS (model dependent) when it detects refrigerant leakage.

- **Sleep Operation**

The SLEEP function is used to decrease energy use while you sleep (**and don't need the same temperature settings to stay comfortable**).

This function can only be activated via remote control. And the Sleep function is not available in FAN or DRY mode.

Press the **SLEEP** button when you are ready to go to sleep. When in COOL mode, the unit will increase the temperature by 1°C (2°F) after 1 hour, and will increase an additional 1°C (2°F) after another hour. When in HEAT mode, the unit will decrease the temperature by 1°C (2°F) after 1 hour, and will decrease an additional 1°C (2°F) after another hour.

The sleep feature will stop after 8 hours and the system will keep running at the last temperature unless changed manually.

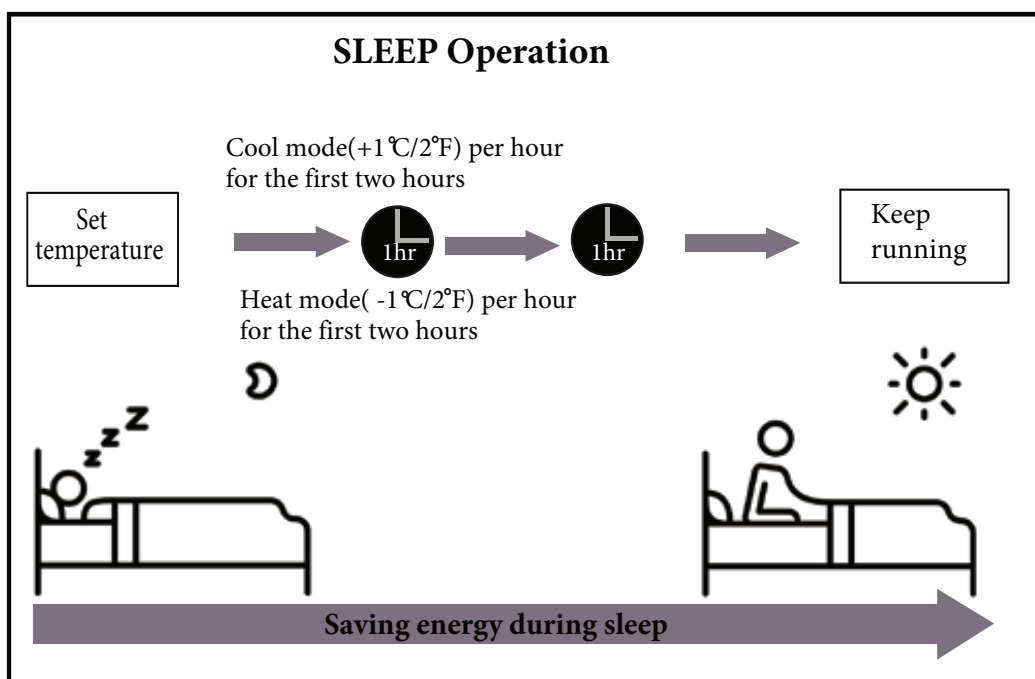

Setting vertical angle of air flow

While the unit is on, use the **SWING/DIRECT** button on remote control to set the direction (vertical angle) of airflow. Please refer to the Remote Control Manual for details.

NOTE ON LOUVER ANGLES

When using COOL or DRY mode, **do not set louver at too vertical an angle for long periods of time.**

This can cause water to condense on the louver blade, which will drop on your floor or furnishings.

When using COOL or HEAT mode, setting the louver at too small an angle can reduce the performance of the unit due to restricted air flow.

NOTE: According to the relative standards requirement, please sets the vertical air flow louver to its maximum angle under heating capacity test.

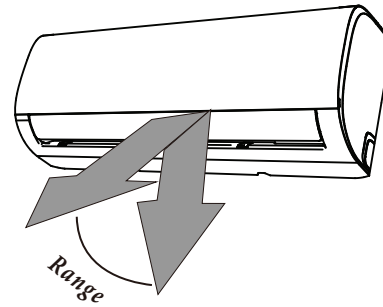

NOTE: Do not move louver by hand. This will cause the louver to become out of sync. If this occurs, turn off the unit and cut the power to it for a few seconds, then restart the unit. This will reset the louver.

Fig. A

Setting horizontal angle of air flow

The horizontal angle of the airflow **must be set manually.** Grip the deflector rod (See Fig.B) and manually adjust it to your preferred direction.

Manual Operation(without remote)

! CAUTION

The manual button is intended for testing purposes and emergency operation only. Please do not use this function unless the remote control is lost and it is absolutely necessary. To restore regular operation, use the remote control to activate the unit. **Unit must be turned off before manual operation.**

To operate your unit manually:

1. Open the front panel of the indoor unit.
2. Locate the **MANUAL CONTROL button** on the right-hand side of the unit.
3. Press the **MANUAL CONTROL button** one time to activate FORCED AUTO mode.
4. Press the **MANUAL CONTROL button** again to activate FORCED COOLING mode.
5. Press the **MANUAL CONTROL button** a third time to turn the unit off.
6. Close the front panel.

! CAUTION

Do not put your fingers in or near the blower and suction side of the unit. The high-speed fan inside the unit may cause injury.

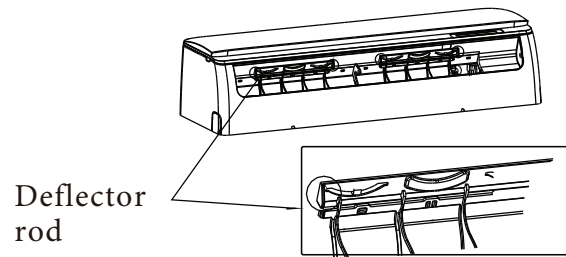
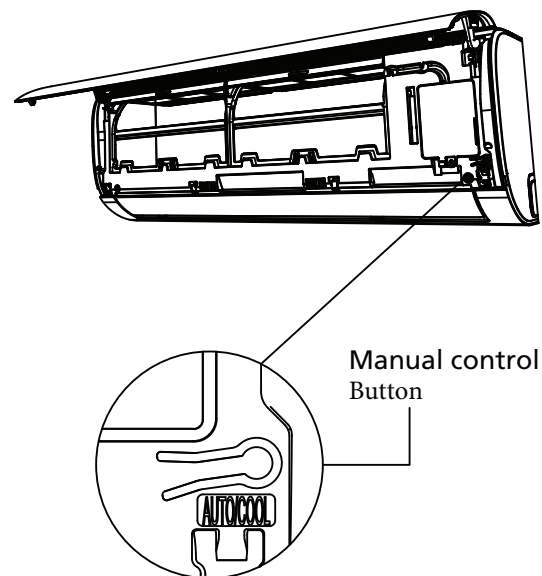

Fig. B



Care and Maintenance

Cleaning Your Indoor Unit

BEFORE CLEANING OR MAINTENANCE

ALWAYS TURN OFF YOUR AIR CONDITIONER SYSTEM AND DISCONNECT ITS POWER SUPPLY BEFORE CLEANING OR MAINTENANCE.

CAUTION

Only use a soft, dry cloth to wipe the unit clean. If the unit is especially dirty, you can use a cloth soaked in warm water to wipe it clean.

- **Do not** use chemicals or chemically treated cloths to clean the unit
- **Do not** use benzene, paint thinner, polishing powder or other solvents to clean the unit. They can cause the plastic surface to crack or deform.
- **Do not** use water hotter than 40°C (104°F) to clean the front panel. This can cause the panel to deform or become discolored.

Cleaning Your Air Filter

A clogged air filter can reduce the cooling efficiency of your unit, and can also be bad for your health.

Make sure to clean the filter once every two weeks.

1. Lift the front panel of the indoor unit.
2. First press the tab on the end of filter to loosen the buckle, lift it up, then pull it towards yourself.
3. Now pull the filter out.
4. If your filter has a small air freshening filter, unclip it from the larger filter. Clean this air freshening filter with a hand-held vacuum.
5. Clean the large air filter with warm, soapy water. Be sure to use a mild detergent.

6. Rinse the filter with fresh water, then shake off excess water.
7. Dry it in a cool, dry place, and refrain from exposing it to direct sunlight.
8. When dry, re-clip the air freshening filter to the larger filter, then slide it back into the indoor unit.
9. Close the front panel of the indoor unit.

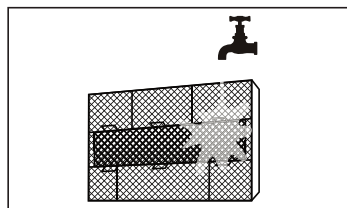
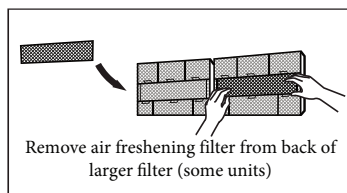
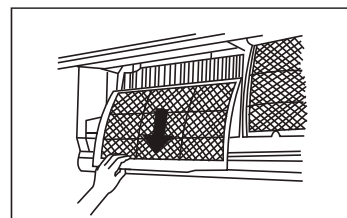
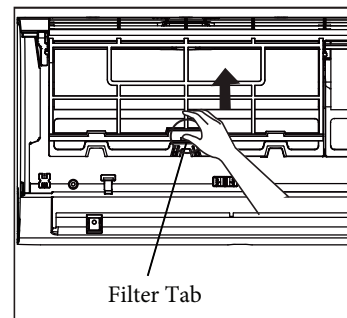

CAUTION

Do not touch air freshening (Plasma) filter for at least 10 minutes after turning off the unit.

⚠ CAUTION

- Before changing the filter or cleaning, turn off the unit and disconnect its power supply.
- When removing filter, do not touch metal parts in the unit. The sharp metal edges can cut you.
- Do not use water to clean the inside of the indoor unit. This can destroy insulation and cause electrical shock.
- Do not expose filter to direct sunlight when drying. This can shrink the filter.

Air Filter Reminders (Optional)

Air Filter Cleaning Reminder

After 240 hours of use, the display window on the indoor unit will flash “CL.” This is a reminder to clean your filter. After 15 seconds, the unit will revert to its previous display.

To reset the reminder, press the **LED** button on your remote control 4 times, or press the **MANUAL CONTROL** button 3 times. If you don't reset the reminder, the “CL” indicator will flash again when you restart the unit.

Air Filter Replacement Reminder

After 2,880 hours of use, the display window on the indoor unit will flash “nF.” This is a reminder to replace your filter. After 15 seconds, the unit will revert to its previous display.

To reset the reminder, press the **LED** button on your remote control 4 times, or press the **MANUAL CONTROL** button 3 times. If you don't reset the reminder, the “nF” indicator will flash again when you restart the unit.

⚠ CAUTION

- Any maintenance and annual or biannual cleaning of outdoor unit should be performed by an authorized dealer or a licensed service provider.
- Any unit repairs should be performed by an authorized dealer or a licensed service provider.

Maintenance – Long Periods of Non-Use

If you plan not to use your air conditioner for an extended period of time, do the following:

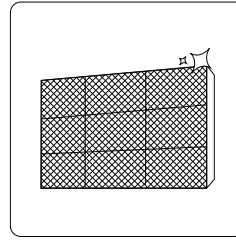

Clean all filters

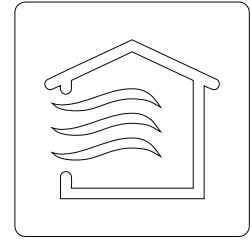

Turn on FAN function until unit dries out completely

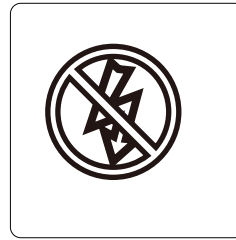

Turn off the unit and disconnect the power

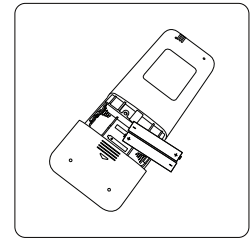

Remove batteries from remote control

Maintenance – Pre-Season Inspection

After long periods of non-use, or before periods of frequent use, do the following:

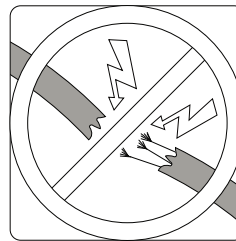

Check for damaged wires

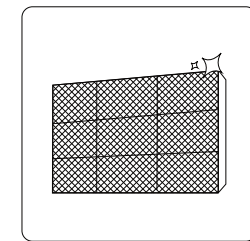

Clean all filters



Check for leaks

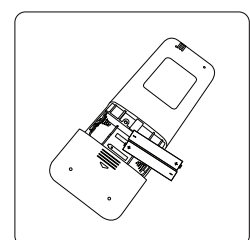

Replace batteries

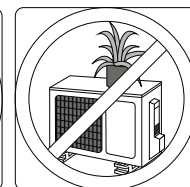
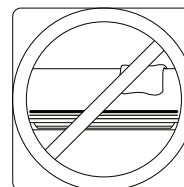

Make sure nothing is blocking all air inlets and outlets

Troubleshooting

SAFETY PRECAUTIONS

If ANY of the following conditions occurs, turn off your unit immediately!

- The power cord is damaged or abnormally warm
- You smell a burning odor
- The unit emits loud or abnormal sounds
- A power fuse blows or the circuit breaker frequently trips
- Water or other objects fall into or out of the unit

DO NOT ATTEMPT TO FIX THESE YOURSELF! CONTACT AN AUTHORIZED SERVICE PROVIDER IMMEDIATELY!

Common Issues

The following problems are not a malfunction and in most situations will not require repairs.

Issue	Possible Causes
Unit does not turn on when pressing ON/OFF button	The Unit has a 3-minute protection feature that prevents the unit from overloading. The unit cannot be restarted within three minutes of being turned off.
The unit changes from COOL/HEAT mode to FAN mode	The unit may change its setting to prevent frost from forming on the unit. Once the temperature increases, the unit will start operating in the previously selected mode again.
	The set temperature has been reached, at which point the unit turns off the compressor. The unit will continue operating when the temperature fluctuates again.
The indoor unit emits white mist	In humid regions, a large temperature difference between the room's air and the conditioned air can cause white mist.
Both the indoor and outdoor units emit white mist	When the unit restarts in HEAT mode after defrosting, white mist may be emitted due to moisture generated from the defrosting process.
The indoor unit makes noises	A rushing air sound may occur when the louver resets its position.
	A squeaking sound may occur after running the unit in HEAT mode due to expansion and contraction of the unit's plastic parts.
Both the indoor unit and outdoor unit make noises	Low hissing sound during operation: This is normal and is caused by refrigerant gas flowing through both indoor and outdoor units.
	Low hissing sound when the system starts, has just stopped running, or is defrosting: This noise is normal and is caused by the refrigerant gas stopping or changing direction.
	Squeaking sound: Normal expansion and contraction of plastic and metal parts caused by temperature changes during operation can cause squeaking noises.

Issue	Possible Causes
The outdoor unit makes noises	The unit will make different sounds based on its current operating mode.
Dust is emitted from either the indoor or outdoor unit	The unit may accumulate dust during extended periods of non-use, which will be emitted when the unit is turned on. This can be mitigated by covering the unit during long periods of inactivity.
The unit emits a bad odor	The unit may absorb odors from the environment (such as furniture, cooking, cigarettes, etc.) which will be emitted during operations.
	The unit's filters have become moldy and should be cleaned.
The fan of the outdoor unit does not operate	During operation, the fan speed is controlled to optimize product operation.
Operation is erratic, unpredictable, or unit is unresponsive	Interference from cell phone towers and remote boosters may cause the unit to malfunction. In this case, try the following: <ul style="list-style-type: none"> • Disconnect the power, then reconnect. • Press ON/OFF button on remote control to restart operation.

NOTE: If problem persists, contact a local dealer or your nearest customer service center Provide them with a detailed description of the unit malfunction as well as your model number.

Troubleshooting

When troubles occur, please check the following points before contacting a repair company.

Problem	Possible Causes	Solution
Poor Cooling Performance	Temperature setting may be higher than ambient room temperature	Lower the temperature setting
	The heat exchanger on the indoor or outdoor unit is dirty	Clean the affected heat exchanger
	The air filter is dirty	Remove the filter and clean it according to instructions
	The air inlet or outlet of either unit is blocked	Turn the unit off, remove the obstruction and turn it back on
	Doors and windows are open	Make sure that all doors and windows are closed while operating the unit
	Excessive heat is generated by sunlight	Close windows and curtains during periods of high heat or bright sunshine
	Too many sources of heat in the room (people, computers, electronics, etc.)	Reduce amount of heat sources
	Low refrigerant due to leak or long-term use	Check for leaks, re-seal if necessary and top off refrigerant
	SILENCE function is activated (optional function)	SILENCE function can lower product performance by reducing operating output. Turn off SILENCE function.

Problem	Possible Causes	Solution
The unit is not working	Power failure	Wait for the power to be restored
	The power is turned off	Turn on the power
	The fuse is burned out	Replace the fuse
	Remote control batteries are dead	Replace batteries
	The Unit's 3-minute protection has been activated	Wait three minutes after restarting the unit
	Timer is activated	Turn timer off
The unit starts and stops frequently	There's too much or too little refrigerant in the system	Check for leaks and recharge the system with refrigerant.
	Incompressible gas or moisture has entered the system.	Evacuate and recharge the system with refrigerant
	The compressor is broken	Replace the compressor
	The voltage is too high or too low	Install a manostat to regulate the voltage
Poor heating performance	The outdoor temperature is extremely low	Use auxiliary heating device
	Cold air is entering through doors and windows	Make sure that all doors and windows are closed during use
	Low refrigerant due to leak or long-term use	Check for leaks, re-seal if necessary and top off refrigerant
Indicator lamps continue flashing	The unit may stop operation or continue to run safely. If the indicator lamps continue to flash or error codes appear, wait for about 10 minutes. The problem may resolve itself. If not, disconnect the power, then connect it again. Turn the unit on. If the problem persists, disconnect the power and contact your nearest customer service center.	
Error code appears and begins with the letters as the following in the window display of indoor unit:		
<ul style="list-style-type: none"> • E(x), P(x), F(x) • EH(xx), EL(xx), EC(xx) • PH(xx), PL(xx), PC(xx) 		

NOTE: If your problem persists after performing the checks and diagnostics above, turn off your unit immediately and contact an authorized service center.

REMOTE CONTROLLER

OWNER'S MANUAL

IMPORTANT NOTE:

Thank you for purchasing our air conditioner. Please read this manual carefully before operating your new air conditioning unit. Make sure to save this manual for future reference.

Table of Contents

Remote Controller Specifications	02
Handling the Remote Controller	03
Buttons and Functions	04
Remote Screen Indicators	07
How to Use Basic Functions	08
How to Use Advanced Functions	11

Remote Controller Specifications

Model	17317000A63547 - RG10A4(D1)/BGEFU1
Rated Voltage	3.0V(Dry batteries R03/LR03×2)
Signal Receiving Range	8m
Environment	-5°C~60°C(23°F~140°F)

Quick Start Guide

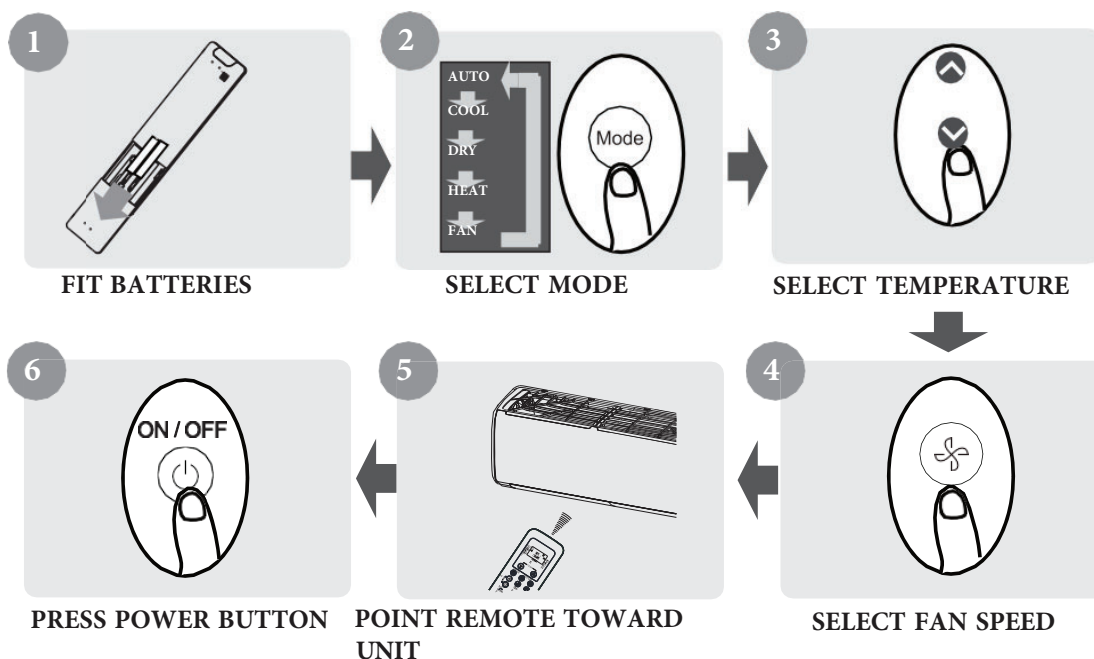

NOT SURE WHAT A FUNCTION DOES?

Refer to the **How to Use Basic Functions** and **How to Use Advanced Functions** sections of this manual for a detailed description of how to use your air conditioner.

SPECIAL

- Button designs on your unit may differ slightly from the example shown.
- If the indoor unit does not have a particular function, pressing that function's button on the remote control will have no effect.
- When there are wide differences between "Remote controller Manual" and "USER'S MANUAL" on function description, the description of "USER'S MANUAL" takes precedent.

Handling the Remote Controller

Inserting and Replacing Batteries

Your air conditioning unit may come with two batteries (some units). Put the batteries in the remote control before use.

1. Slide the back cover from the remote control downward, exposing the battery compartment.
2. Insert the batteries, paying attention to match up the (+) and (-) ends of the batteries with the symbols inside the battery compartment.
3. Slide the battery cover back into place.

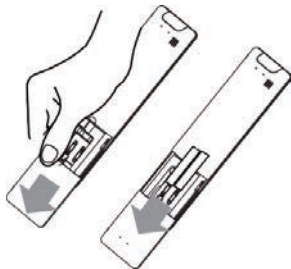

! BATTERY NOTES

For optimum product performance:

- Do not mix old and new batteries, or batteries of different types.
- Do not leave batteries in the remote control if you don't plan on using the device for more than 2 months.



BATTERY DISPOSAL

Do not dispose of batteries as unsorted municipal waste. Refer to local laws for proper disposal of batteries.

TIPS FOR USING REMOTE CONTROL

- The remote control must be used within 8 meters of the unit.
- The unit will beep when remote signal is received.
- Curtains, other materials and direct sunlight can interfere with the infrared signal receiver.
- Remove batteries if the remote will not be used more than 2 months.

NOTES FOR USING REMOTE CONTROL

The device could comply with the local national regulations.

- In USA, this device complies with part 15 of the FCC Rules. Operation is subject to the following two conditions:
 - (1) This device may not cause harmful interference, and
 - (2) this device must accept any interference received, including interference that may cause undesired operation.

This equipment has been tested and found to comply with the limits for a Class B digital device, pursuant to part 15 of the FCC Rules. These limits are designed to provide reasonable protection against harmful interference in a residential installation. This equipment generates, uses and can radiate radio frequency energy and, if not installed and used in accordance with the instructions, may cause harmful interference to radio communications. However, there is no guarantee that interference will not occur in a particular installation. If this equipment does cause harmful interference to radio or television reception, which can be determined by turning the equipment off and on, the user is encouraged to try to correct the interference by one or more of the following measures:

- Reorient or relocate the receiving antenna.
- Increase the separation between the equipment and receiver.
- Connect the equipment into an outlet on a circuit different from that to which the receiver is connected.
- Consult the dealer or an experienced radio/TV technician for help.
- Changes or modifications not approved by the party responsible for compliance could void user's authority to operate the equipment.

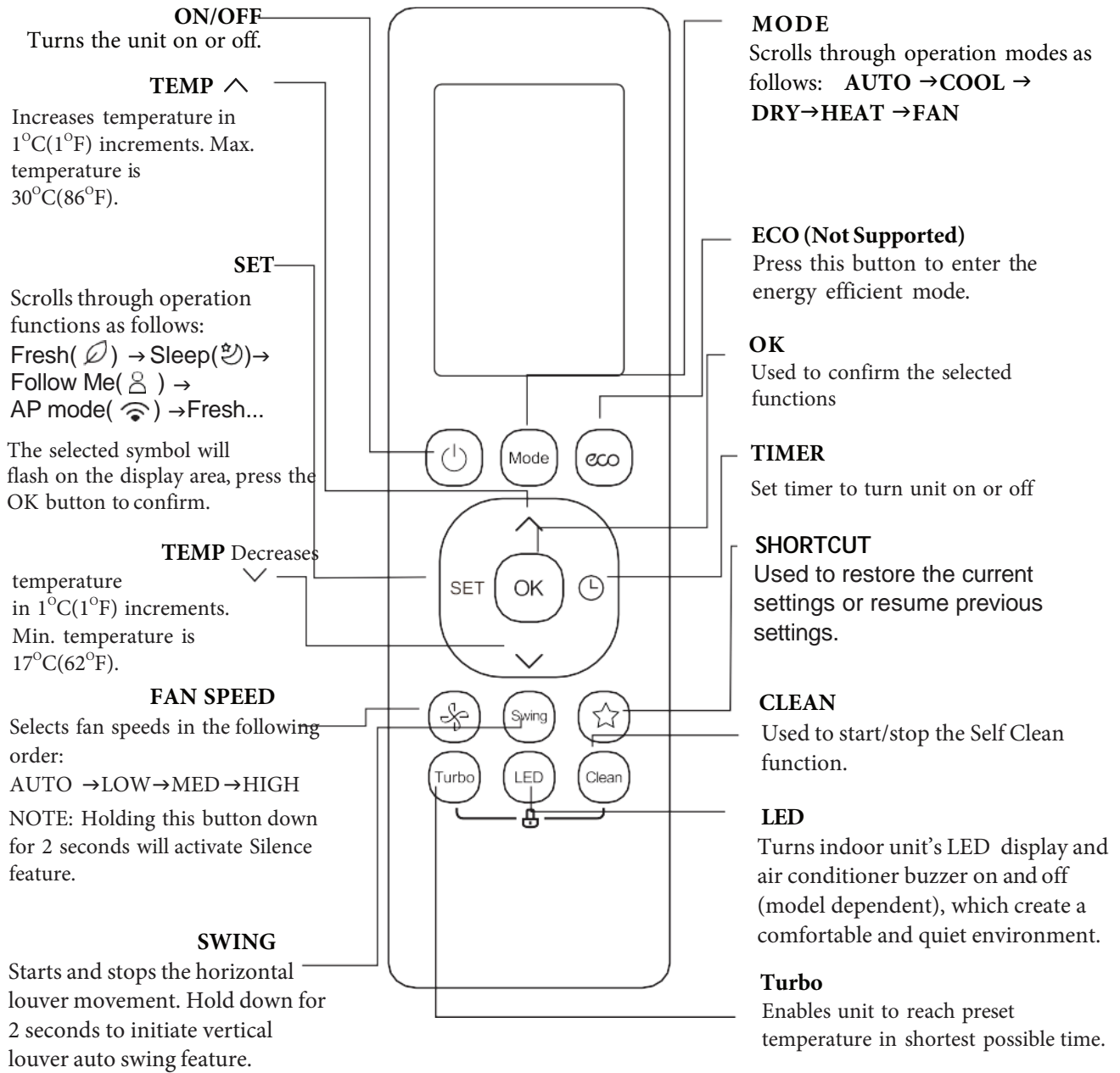

Model: 17317000A63547 - RG10A4(D1)/BGEFU1

NOTE: For **RG10A4(D1)/BGEFU1** press together ^ & v buttons at the same time for 3 seconds will alternate the temperature display between the °C & °F scale.

Fresh, Eco, and UV-C lamp functions are not supported modes on this device.

Remote Screen Indicators

Information is displayed when the remote controller is power up.

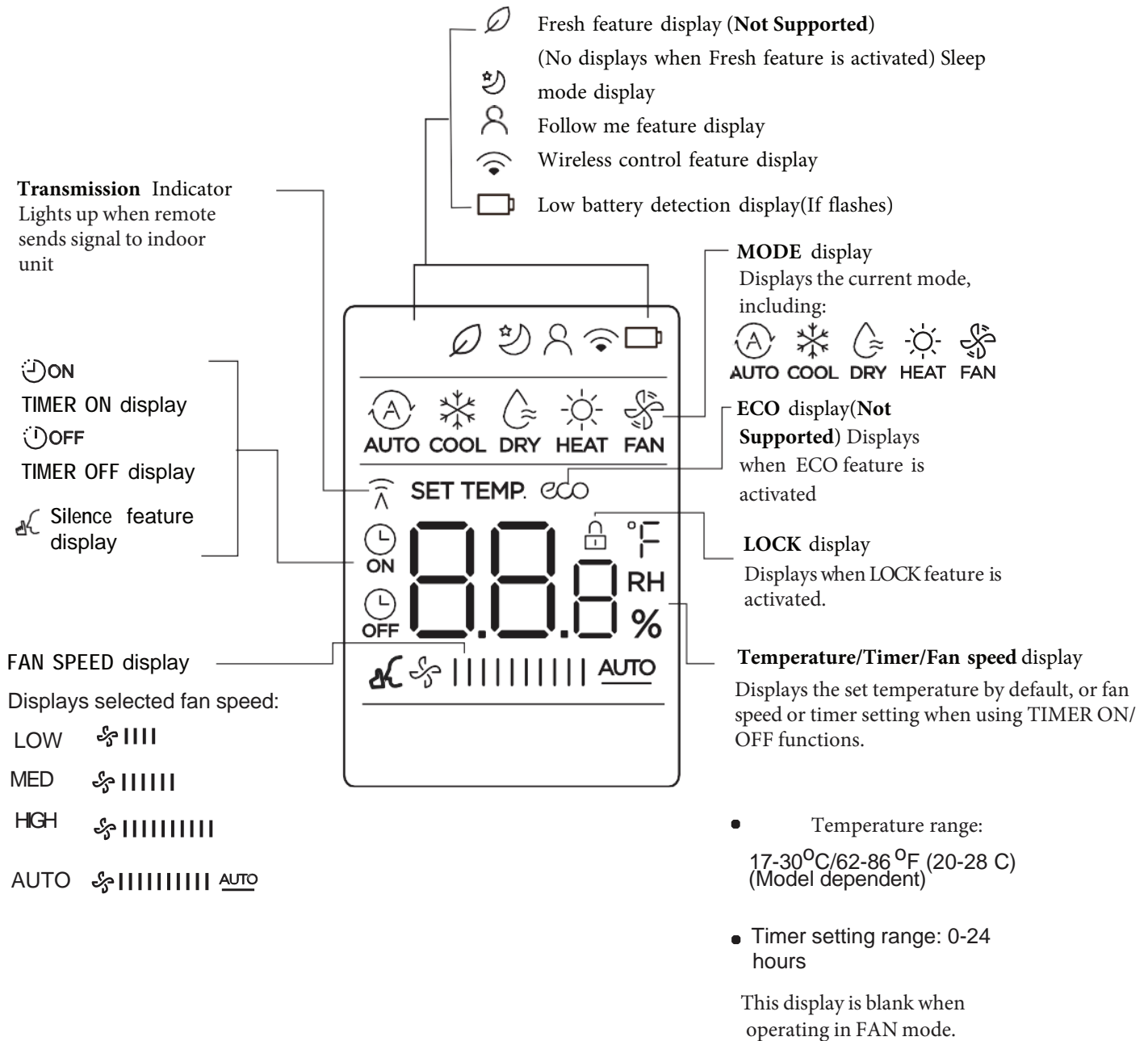

Note:

All indicators shown in the figure are for the purpose of clear presentation. But during the actual operation, only the relative function signs are shown on the display window.

How to Use Basic Functions

Basic operation

ATTENTION! Before operation, please ensure the unit is plugged in and power is available.

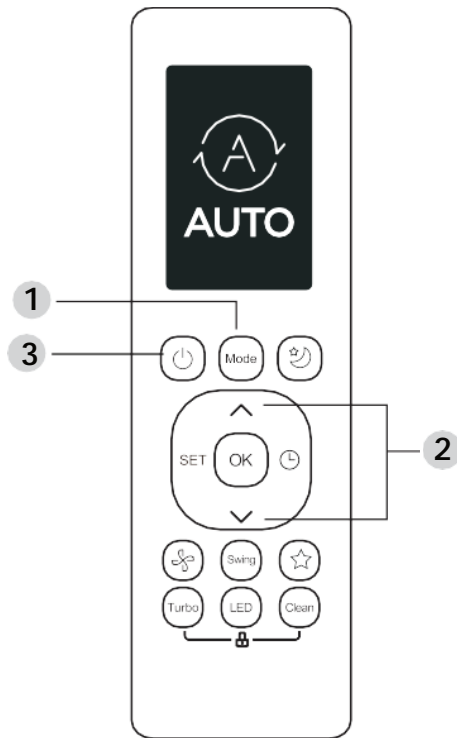

COOL Mode

1. Press the **MODE** button to select **COOL** mode.
2. Set your desired temperature using the **TEMP** \wedge or **TEMP** \vee button.
3. Press **FAN** button to select the fan speed: AUTO, LOW, MED or HIGH.
4. Press the **ON/OFF** button to start the unit.

SETTING TEMPERATURE

The operating temperature range for units is 17-30°C (62-86°F)/20-28 °C(68-82.4°F). You can increase or decrease the set temperature in 1°C (1°F) increments.

AUTO Mode

In AUTO mode, the unit will automatically select the COOL, FAN, or HEAT operation based on the set temperature.

1. Press the **MODE** button to select **AUTO**.
2. Set your desired temperature using the **TEMP**

\wedge or **TEMP** \vee button.

3. Press the **ON/OFF** button to start the unit.

NOTE: FAN SPEED can't be set in AUTO mode.

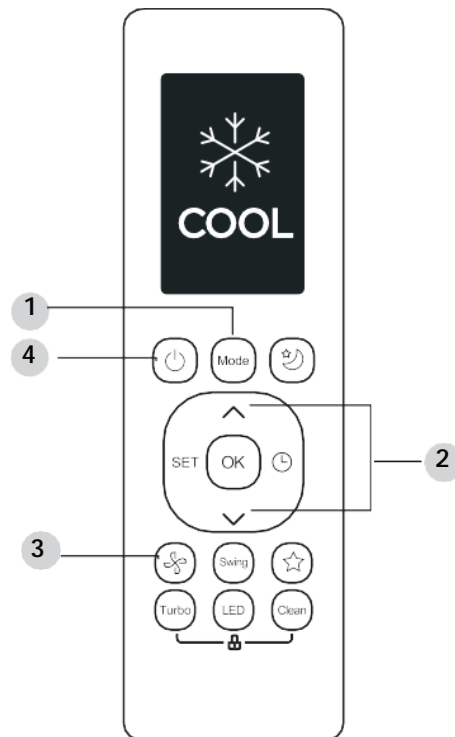

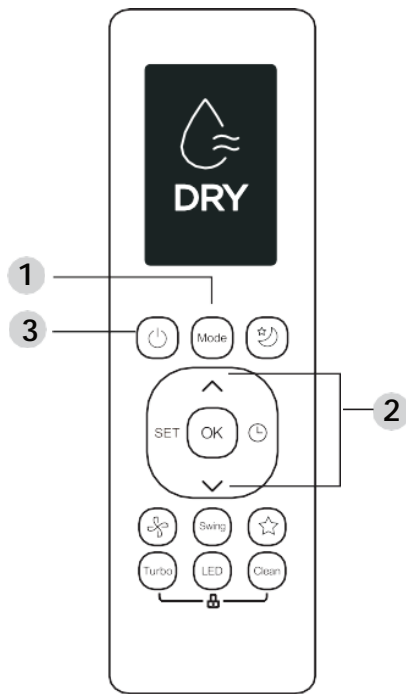

DRY Mode (dehumidifying)

1. Press the **MODE** button to select **DRY**.
2. Set your desired temperature using the **TEMP** \wedge or **TEMP** \vee button.
3. Press the **ON/OFF** button to start the unit.

NOTE: FAN SPEED cannot be changed in DRY mode.

FAN Mode

1. Press the **MODE** button to select **FAN** mode.
2. Press **FAN** button to select the fan speed: AUTO, LOW, MED or HIGH.
3. Press the **ON/OFF** button to start the unit.

NOTE: You can't set temperature in FAN mode. As a result, your remote control's LCD screen will not display temperature.

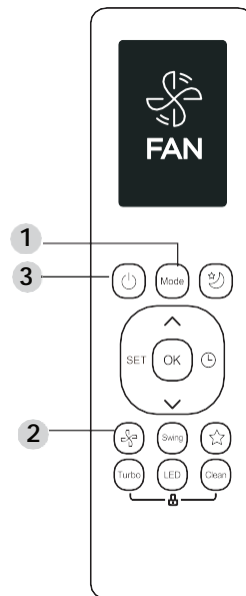

HEAT Mode

1. Press the **MODE** button to select **HEAT** mode.
2. Set your desired temperature using the **TEMP** \wedge or **TEMP** \vee button.
3. Press **FAN** button to select the fan speed: AUTO, LOW, MED or HIGH.
4. Press the **ON/OFF** button to start the unit.

NOTE: As outdoor temperature drops, the performance of your unit's HEAT function may be affected. In such instances, we recommend using this air conditioner in conjunction with other heating appliances.

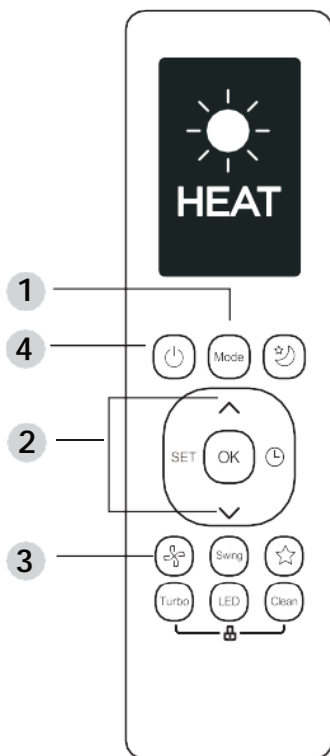

Setting the TIMER

TIMER ON/OFF - Set the amount of time after which the unit will automatically turn on/off.

TIMER ON setting

Press TIMER button to initiate the ON time sequence.



Press Temp. up or down button for multiple times to set the desired time to turn on the unit.

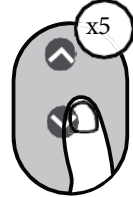

Point remote to unit and wait 1sec, the TIMER ON will be activated.



TIMER OFF setting

Press TIMER button to initiate the OFF time sequence.



Press Temp. up or down button for multiple times to set the desired time to turn off the unit.



Point remote to unit and wait 1sec, the TIMER OFF will be activated.



NOTE:

1. When setting the TIMER ON or TIMER OFF, the time will increase by 30 minutes increments with each press, up to 10 hours. After 10 hours and up to 24, it will increase in 1 hour increments. (For example, press 5 times to get 2.5h, and press 10 times to get 5h.) The timer will revert to 0.0 after 24.
2. Cancel either function by setting its timer to 0.0h.

TIMER ON & OFF setting(example)

Keep in mind that the time periods you set for both functions refer to hours after the current time.

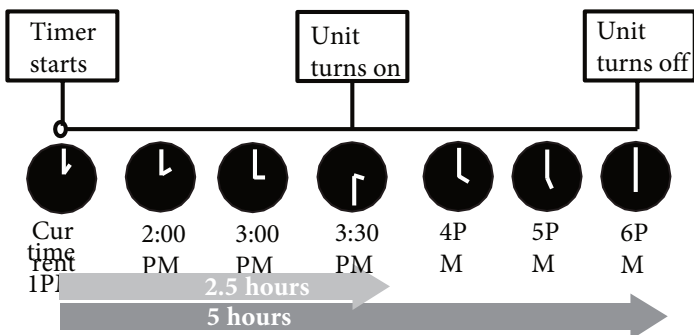
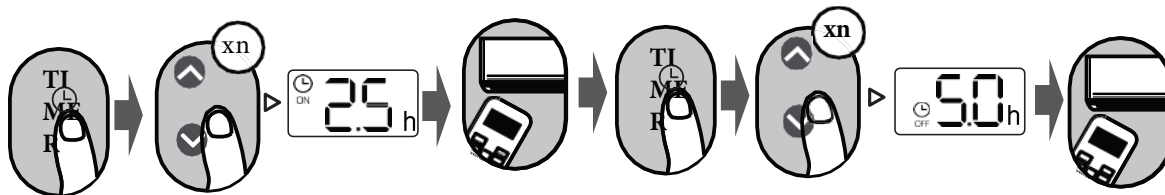

Example: If current timer is 1:00PM, to set the timer as above steps, the unit will turn on 2.5h later (3:30PM) and turn off at 6:00PM.

How to Use Advanced Functions

Swing function

Press Swing button

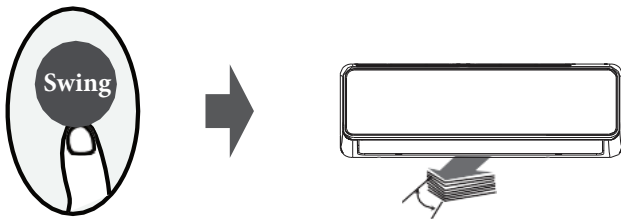

The horizontal louver will swing up and down automatically when pressing Swing button. Press again to make it stop.

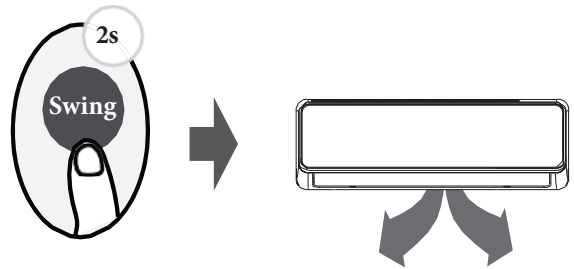

Keep pressing this button more than 2 seconds, the vertical louver swing function is activated. (Model dependent)

LED DISPLAY

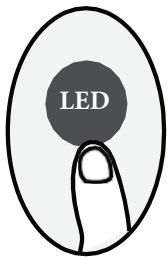

Press LED button

Press this button to turn on and turn off the display on the indoor unit.

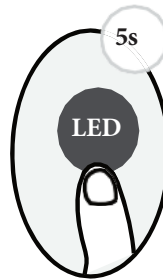

Press this button more than 5 seconds (some units)

Keep pressing this button more than 5 seconds, the indoor unit will display the actual room temperature. Press more than 5 seconds again will revert back to display the setting temperature.

Silence function



Keep pressing Fan button for more than 2 seconds to activate/disable Silence function (some units). Due to low frequency operation of compressor, it may result in insufficient cooling and heating capacity. Press ON/OFF, Mode, Sleep, Turbo or Clean button while operating will cancel silence function.

ECO function

Press ECO button(Not Supported)



FP function



The unit will operate at high fan speed (while compressor on) with temperature automatically set to 8 C/46 F.

Note: This function is for heat pump air conditioner only.

Press this button 2 times during one second under HEAT Mode and setting temperature of 17 C/62 F to activate FP function.

Press On/Off, Sleep, Mode, Fan and Temp. button while operating will cancel this function.

LOCK function

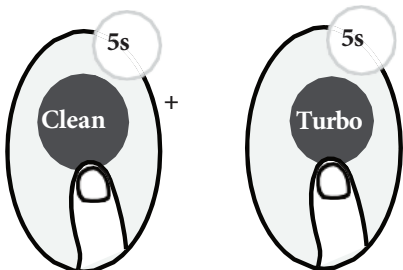

Press together **Clean** button and **Turbo** button at the same time more than 5 seconds to activate Lock function. All buttons will not respond except by pressing these two buttons for two seconds again to disable locking.

SHORTCUT function

Press SHORTCUT button(some units)



Push this button when remote controller is on, the system will automatically revert back to the previous settings including operating mode, setting temperature, fan speed level and sleep feature (if activated).

If pushing more than 2 seconds, the system will automatically restore the current operation settings including operating mode, setting temperature, fan speed level and sleep feature (if activated).

Clean Function

Press CLEAN button



Airborne bacteria can grow in the moisture that condenses around heat exchanger in the unit. With regular use, most of this moisture is evaporated from the unit.

By pressing the CLEAN button, your unit will clean itself automatically. After cleaning, the unit will turn off automatically. Pressing the CLEAN button mid-cycle will cancel the operation and turn off the unit. You can use CLEAN as often as you like.

Note: You can only activate this function in COOL or DRY mode.

TURBO Function

Press TURBO button



When you select Turbo feature in COOL mode, the unit will blow cool air with strongest wind setting to jump-start the cooling process.

When you select Turbo feature in HEAT mode, for units with Electric heat elements, the Electric HEATER will activate and jump-start the heating process.

SET function

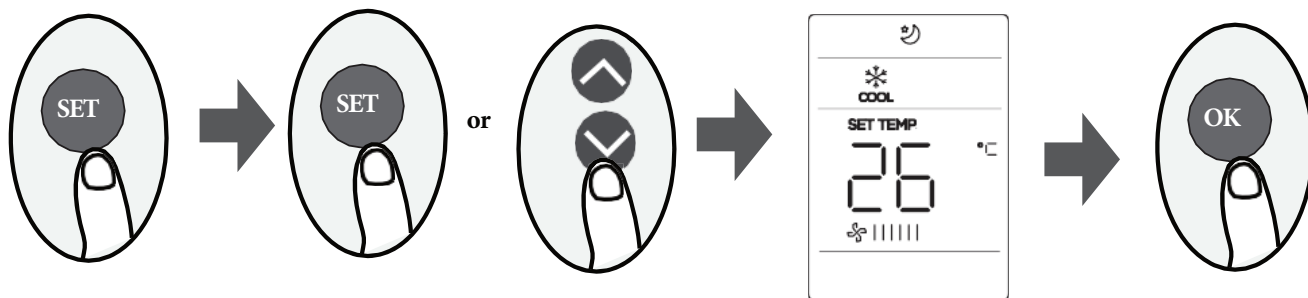

- Press the SET button to enter the function setting, then press SET button or TEMP ▼ or TEMP ▲ button to select the desired function. The selected symbol will flash on the display area, press the OK button to confirm.
- To cancel the selected function, just perform the same procedure as above.
- Press the SET button to scroll through operation functions as follows:
 Fresh* (🌿) → Sleep* (🌙) → Follow Me (👤) → AP mode (📶)
 [*]: If your remote controller has Fresh and Sleep button, you can not use the SET button to select the Fresh (not supported) and Sleep feature.

FRESH function (🌿) (not supported) :

Sleep function (🌙) :

The SLEEP function is used to decrease energy use while you sleep (and don't need the same temperature settings to stay comfortable). This function can only be activated via remote control. For details review "sleep function" in the users manual

Note: The SLEEP function is not available in FAN or DRY mode.

AP function (📶) (some units) :

Choose AP mode to do wireless network configuration. For some units, it doesn't work by pressing the SET button. To enter the AP mode, continuously press the LED button seven times in 10 seconds.

Follow me function (👤) :

The FOLLOW ME function enables the remote control to measure the temperature at its current location and send this signal to the air conditioner every 3 minutes interval. When using AUTO, COOL or HEAT modes, measuring ambient temperature from the remote control (instead of from the indoor unit itself) will enable the air conditioner to optimize the temperature around you and ensure maximum comfort.

NOTE: Press and hold Turbo button for seven seconds to start/stop memory feature of Follow Me function.

- If the memory feature is activated, " On" displays for 3 seconds on the screen.
- If the memory feature is stopped, " OF" displays for 3 seconds on the screen.
- While the memory feature is activated, press the ON/OFF button, shift the mode or power failure will not cancel the Follow me function.