

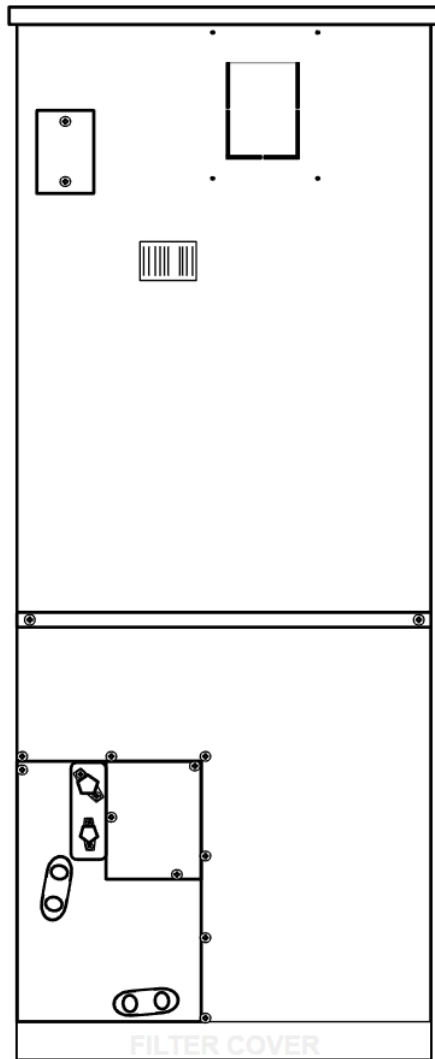

BMAH QUICK INSTALL GUIDE



MODELS

- BMAH1820
- BMAH2420
- BMAH3018
- BMAH3618
- BMAH4816
- BMAH6016

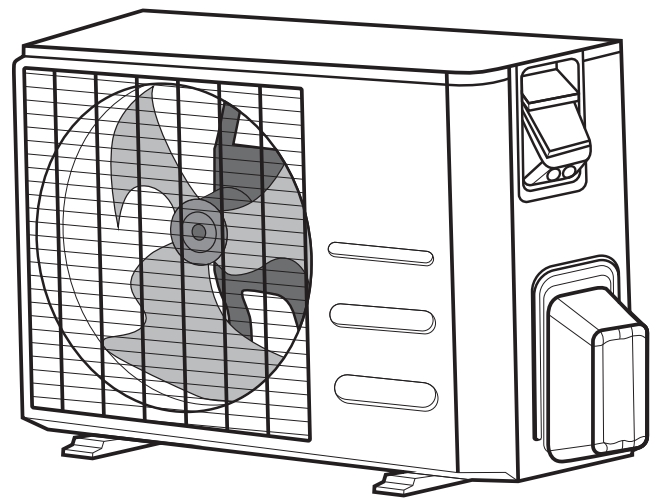

Prep for the Installation

1

Determine the orientation of the indoor unit.

Upflow Downflow

Horizontal Right

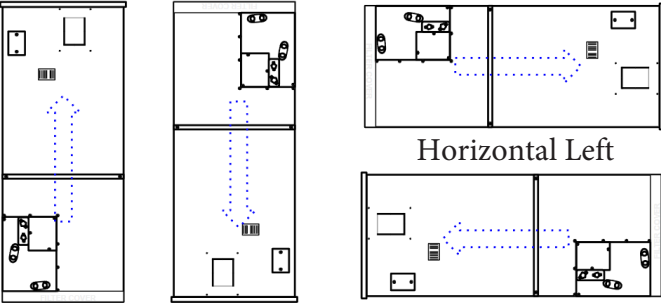

Horizontal Left

2

Open the indoor unit and remove any paperwork and accessories.

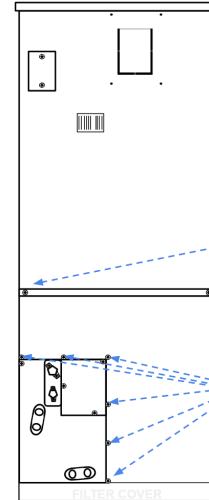

Remove two screws in the center

Remove six screws in the lower section.

3

Verify the proper electrical voltage and amperage is available.

The BMAH series requires dedicated 208/240 volt power for the outdoor unit.

The indoor unit also requires dedicated 208/240-volt power, which should be run either directly to the indoor unit if no heat kit is installed, or to the heat kit if one is present.

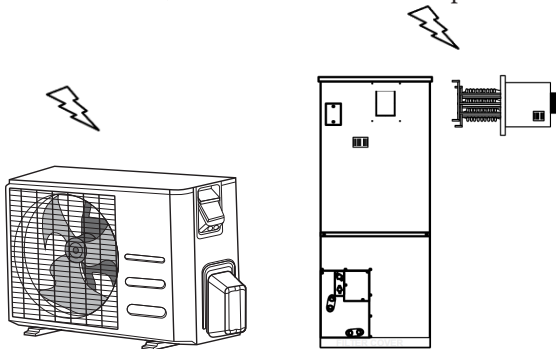

4

Choose the location to place the outdoor unit.

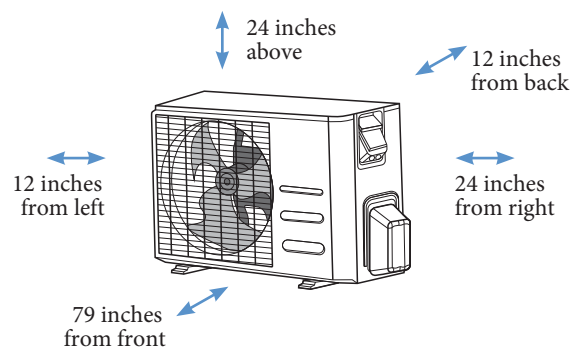

! Maintain listed clearances

5

Upflow ductwork considerations.

It is common for upflow furnaces to pull their return air from the lower left or right side of the furnace. The return on the BMAH indoor unit always comes in from the end of the unit. An upflow return air box such as the SBFD30, or SBFD36 may be required.

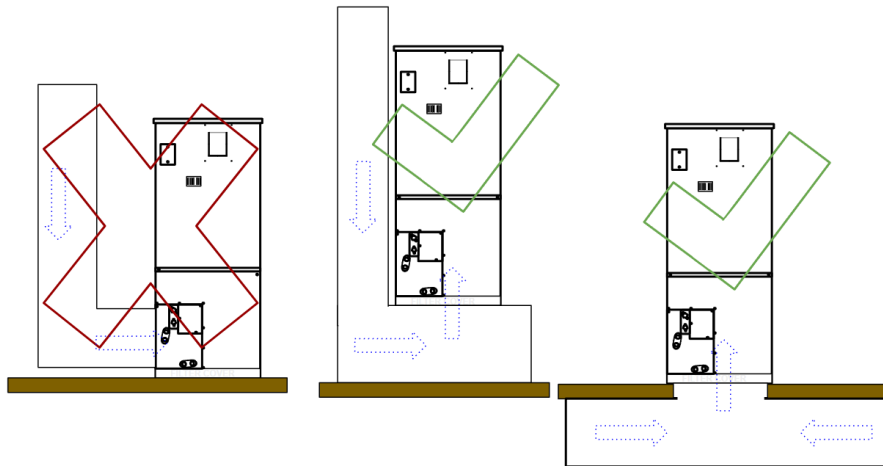

6

Electrical changes

Fossil fuel furnaces are typically 110 volt with a 15 or 20 amp breaker.

This air handler is 208/240 volt with a minimum breaker of 15 amps with no heat kit.

If you install a heat kit, you will need 208/240 volt with a breaker ranging from 15-150 amps (60/60/30) depending on the capacity of the heat kit.

Please consult with an electrician prior to switching from a fossil fuel heat source.

7

Downflow or horizontal right installations.

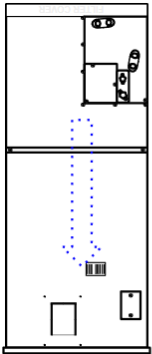

If installing the indoor unit in a downflow or horizontal right configuration, it is necessary to rotate the evaporator coil 180 degrees. Refer to the full installation instructions for a detailed description.

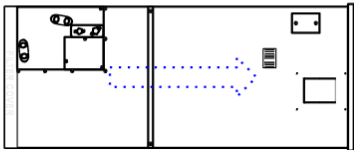

8

Secure the unit to the supply and return air duct system.

If installing a heater coil, wait on connecting to the supply ducts until after the coil installation is complete.

The BMAH series indoor unit is a whole house, multi positional, air handler that is designed to be dropped into an existing duct system or have a new duct system installed with the unit.

Supply air is the heated or cooled air leaving the unit.

Return air is the air coming back to the unit to be heated or cooled.

9

Drain installation.

You must install a drain to remove the condensate.

3/4 inch PVC is required.

A drain trap is required.

If you can't maintain a downwards slope, then a condensate pump is required. A 1/4 inch drop or more per foot of horizontal run is recommended.

It is recommended to connect both the primary and secondary drains or to use kit017 with a drain trap and float switch. The lowest drain outlet is always the primary, while the one slightly above it serves as the secondary drain.

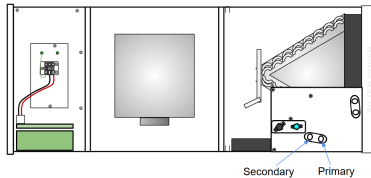
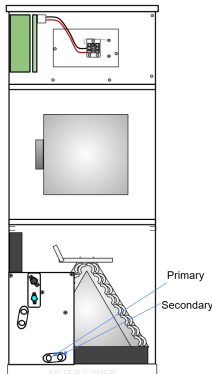

10

Drain Connection Design.

Drain connection design.
Not to scale.

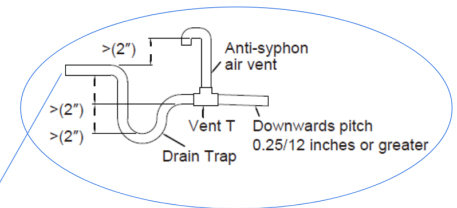
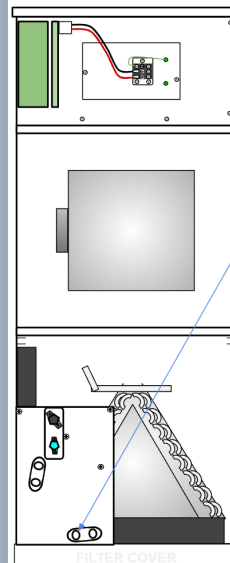

11

Installing in a downflow or horizontal right orientation.

Refer to the "Reversing instructions" section of the full install manual.

Horizontal right

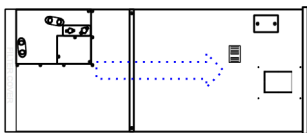

Downflow

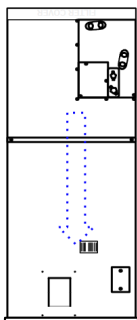

12

Unplug the sensors .

There are up to four sensors and an EEV connected to the evaporator coil. Follow the wiring back to the control board, label each wire with masking tape and unplug the sensors and EEV from the board.

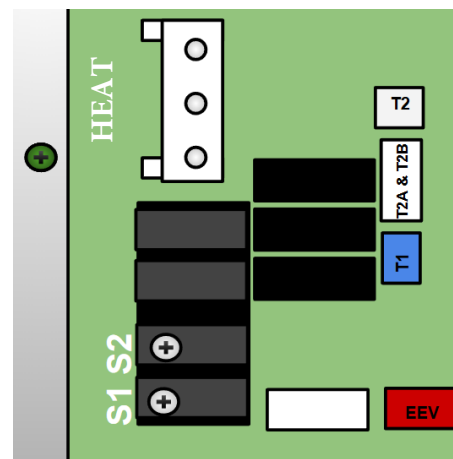

13

Reposition the T1 Sensor.

The T1 sensor is in a clear plastic tube that extends from the drain pan and points downwards, near the line set connections.

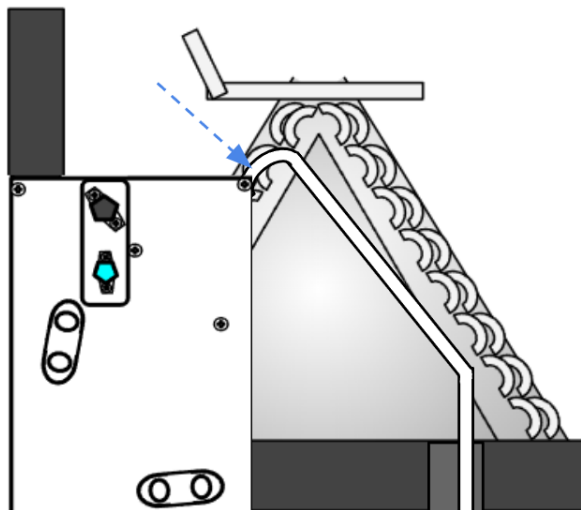

14

Reposition the T1 Sensor.

Secure the T1 sensor parallel to the distributor tube as shown below. Secure in place with a zip tie. **Be sure not to over tighten.**

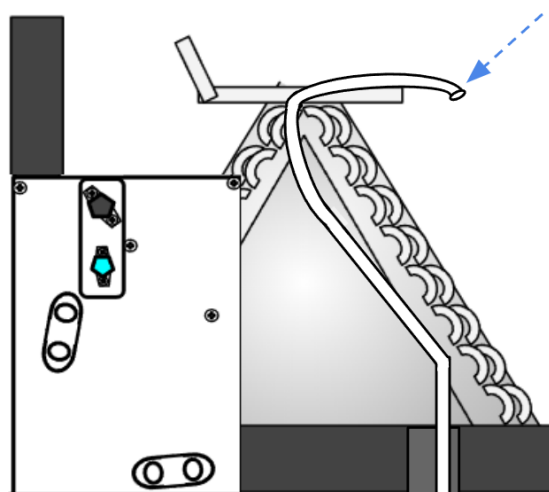

15

Remove the knockout panel from the upper cover.

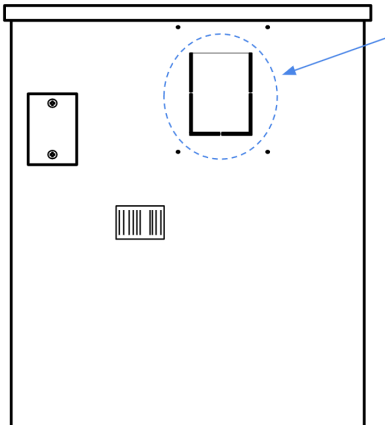

16

Disconnect the black and red wires from L1 and L2.

Cut back any attached connector and strip 1/2 inch of insulation from the end of the wires.

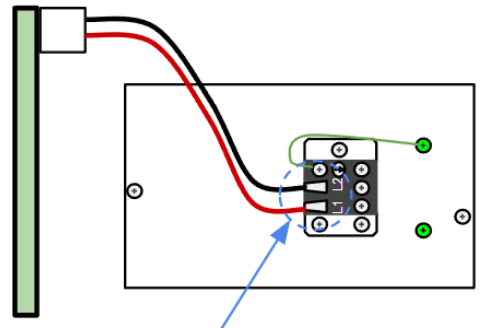

17

Take out the electric auxiliary heating cover by removing two screws.

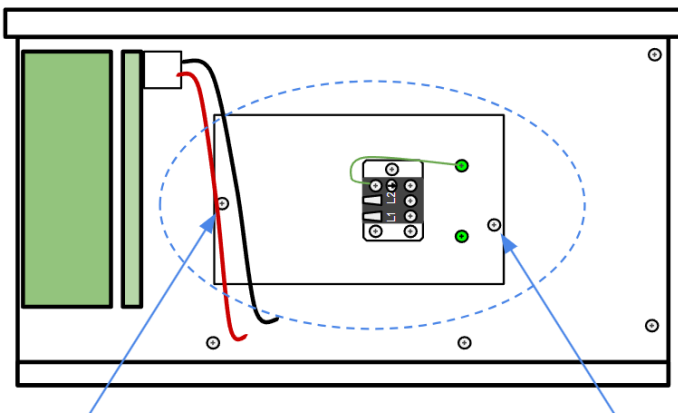

18

Install the heat kit in the cabinet.

Secure the lip of the heat kit over the rail and secure it in place with a screw in the pre-drilled location.

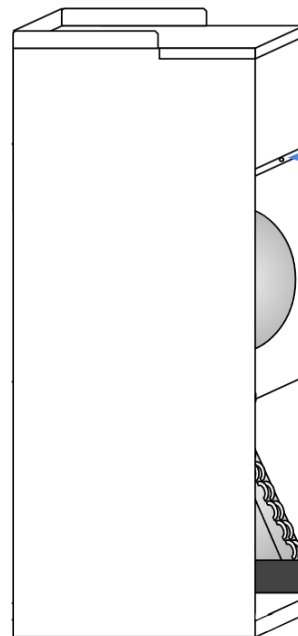

Attach the smaller connector from the heater coil to the Heat receptacle on the board refer to the image in step 12

19

Mount the heater coil in the same location as the axillary heating cover you removed previously.

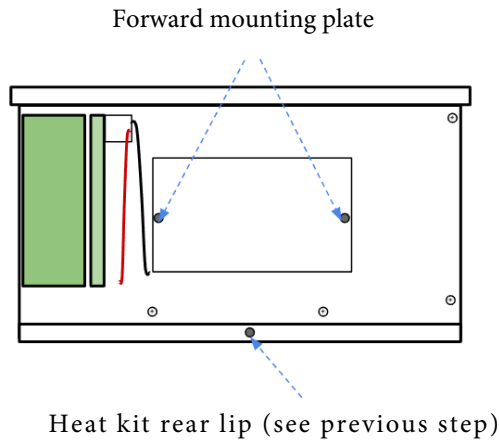

20

Connect the black and red wire from the board.

Connect the black and red wires you disconnected previously and wire them into the highest amperage breaker on the heater coil.

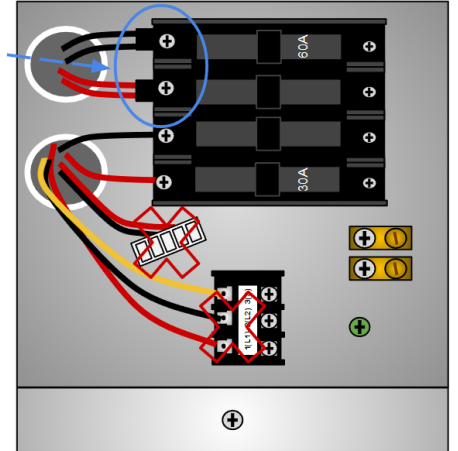

DO NOT use the 5 pin connector . **DO NOT** use 1(L1), 2(L2), 3(S).

21



Powering the indoor unit.

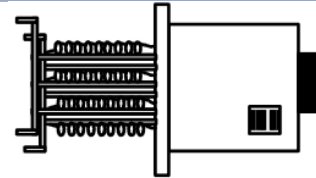

If you install a heat kit in the BMAH indoor unit, you will only run power inside to the heat kit.

The electricity powering the heat kit will also supply power for the air handler.

- 3 kw heater coil = 208/240 volt, 20 amp max breaker
- 5 kw heater coil = 208/240 volt, 30 amp max breaker
- 8 kw heater coil = 208/240 volt, 45 amp max breaker
- 10 kw heater coil = 208/240 volt, 60 amp max breaker
- 15 kw heater coil = 208/240 volt, 60 amp, **and** 30 amp max breakers
- 20 kw heater coil = 208/240 volt, **two** 60 amp max breakers
- 25kw heater coil = 208/240 volt, **two** 60 amp max breakers **and** a 30 amp max breaker. (only compatible with BMAH6016)

22

Run power to the heat kit.

The amperage and the number of circuits will vary depending on the heat kit used. Please refer to the chart in the previous step. The example below is for a 15kw heat kit. Match the breaker size in your electrical panel to the breaker on the heat kit.

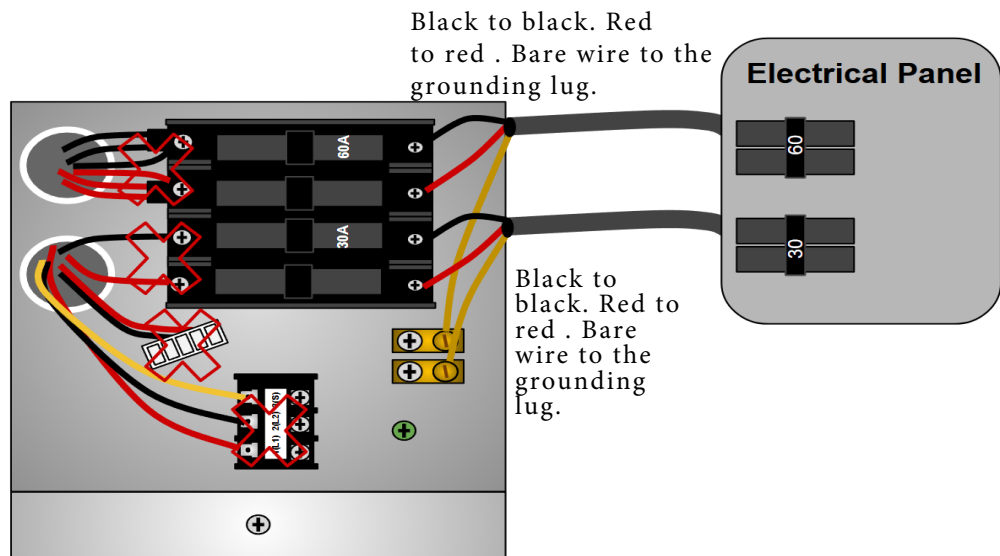

- 
Any high voltage electrical installation should be performed by an electrician or contractor.
- Make sure the electricity is off.**
- Follow all local and national electrical codes.**
- Hot, hot, ground, no neutral is used.**

23

Install the silicon cover.

When installed, the breakers of the heater coil will protrude through the opening you created in the front of the cover.

The heat kit comes with an adhesive frame that you secure over that opening.

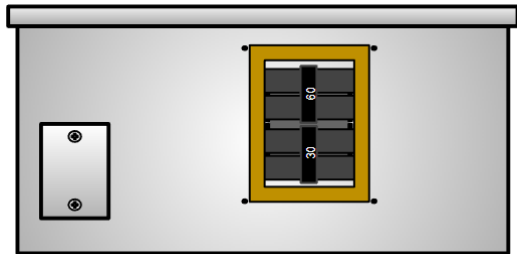
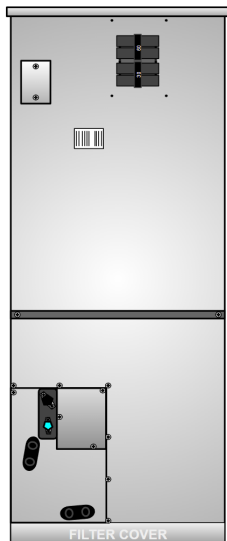

Next install the included silicone breaker cover. Secure it in position with 4 screws, ensuring that On/Off is oriented correctly.

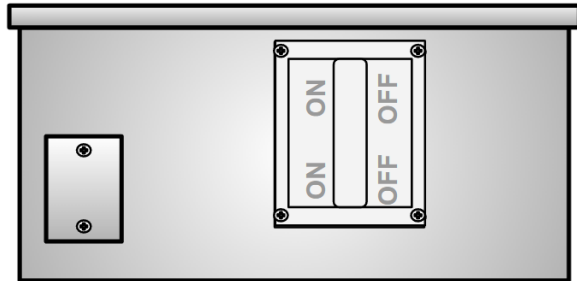

24

Run power to the indoor disconnect

Each indoor unit requires a 208/240 volt, 15 amp max breaker if you are not installing a heat kit.

If you don't have a heat kit, you will need a disconnect box and a whip to feed power into the indoor unit.

Connect the incoming power to the disconnect on the line terminals.

Bare wire to a ground lug.

- **Wiring on the disconnect is shown as load, line, line, load.**
- **Make sure to verify those locations prior to wiring.**
- **Hot, hot, ground, no neutral is used.**

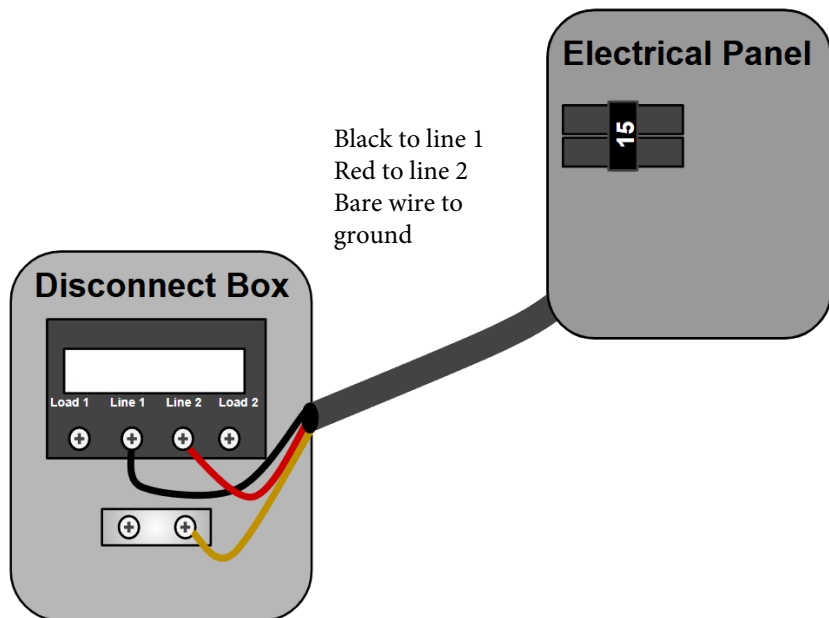

25

Run power from the disconnect to the indoor unit.

Connect the load terminals of the disconnect box to the indoor unit.

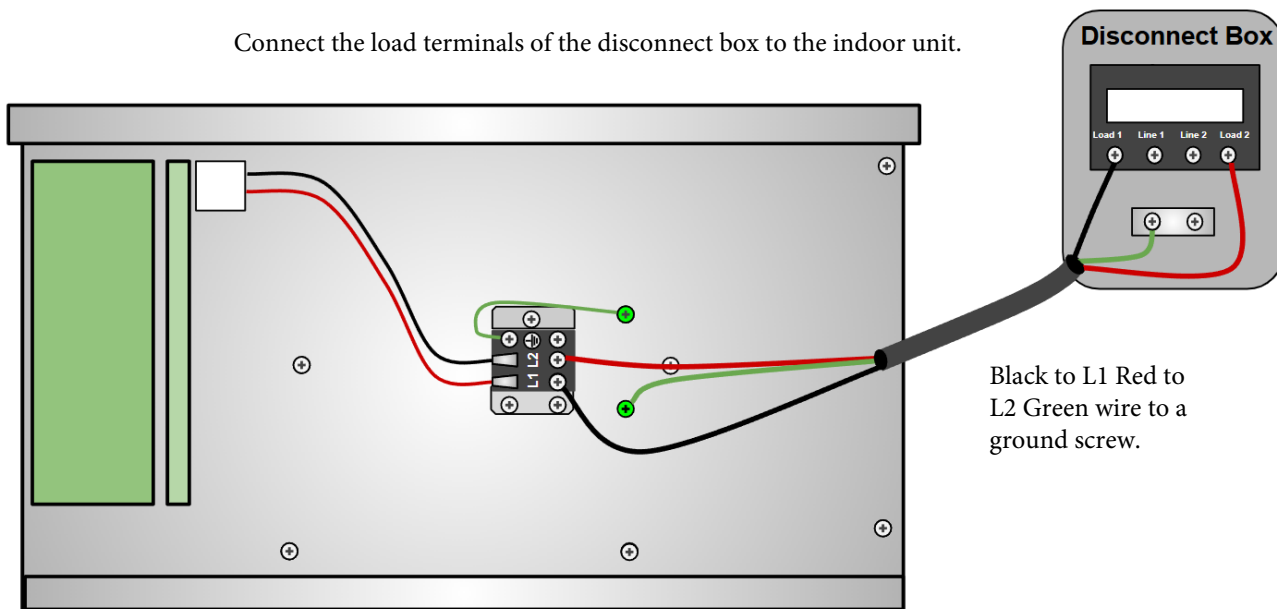

Communication Wiring

26

S1, S2 Communication

The indoor unit is equipped with two boards.

One is facing forwards and one facing the interior of the cabinet.

S1, S2 terminals are located on the board facing the interior.

ALWAYS connect the S1, S2 terminals between the indoor and outdoor units.

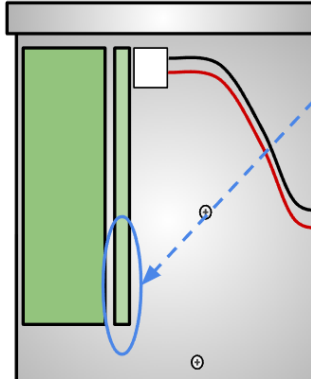

27

Connect the 18/2 wire to S1, S2.

Black to S1

Red to S2

Bare wire to the ground screw

These will be connected later to the S1, S2 terminals on the outdoor unit.

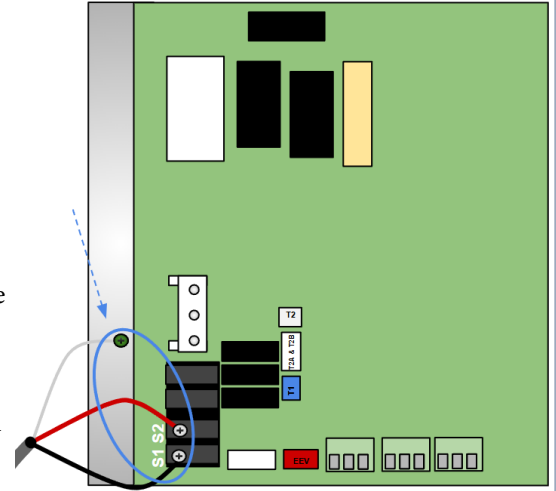

Wall Controller Wiring (if used)

28

HA, HB for wall controller

The indoor unit is equipped with two boards.

One is facing forwards and one is facing the interior of the cabinet.

HA, HB terminals are located on the board facing forward.

HA and HB terminals are only used if you install the included wall controller.

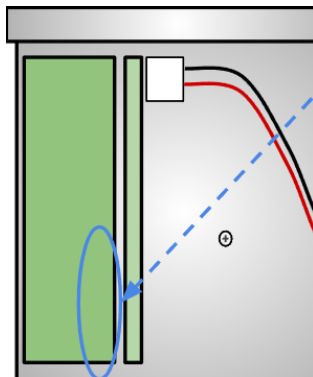

29

Wire HA, HB

Use 18/2 stranded shielded wire

Black to HA

Red to HB

Bare wire to the green ground screw that you used for S1 and S2.

You must connect to the HA HB terminals using 18/2 stranded shielded wire. Do not use any included harness.

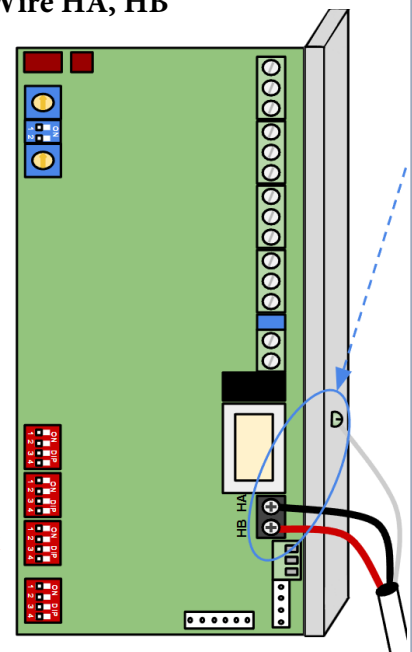

Thermostat Wiring (if used)

30

Control Options.

The BMAH system is a variable capacity, hyper heat, heat pump. It is optimized for efficiency and air distribution. The included wall controller is designed to optimize efficiency and air distribution by keeping the fan on at all times when in cooling mode and maintaining around a 4F temperature swing around the set point.

If you prefer a more standard system operation, it is recommended to use a 24-volt thermostat, which will maintain a tighter temperature swing and cycle the fan on and off when in cooling mode.

The rated efficiencies are reflective of using a 24 volt thermostat. The system retains its variable output and communication when using a 24 volt thermostat. **ALWAYS connect the S1, S2** terminals between the indoor and outdoor units.

32

Thermostat Wiring Diagrams.

Several wiring diagrams are located in the full BMAH installation manual Online. Please refer to that document and/or call us at (800) 865 5931 for assistance in wiring your thermostat.

The only low voltage connections you should ever make at the outdoor unit is to the S1 and S1 terminals.

The S1 and S2 terminals allow the indoor and outdoor units to communicate. This optimizes the system's performance.

No other low voltage configuration at the outdoor unit is approved.

31

Flip SW1 1 to On.

Make sure the power is off before adjusting the dip switch.

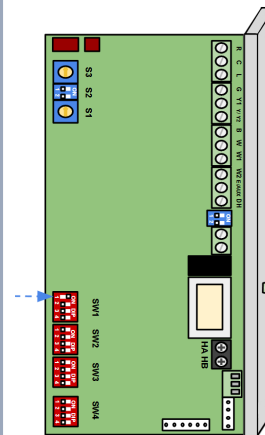

Flip the SW1 1 dip switch to the ON position.

Do not adjust any other dip switch.

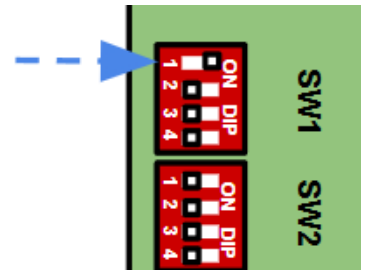

Mount the Outdoor Unit

33

Mount on a pad, bracket, or stand.

It is highly recommended to install the outdoor unit on a stand or bracket. Especially if you live in an area that can get snow.

! Position the outdoor unit so it is blowing away from the structure.

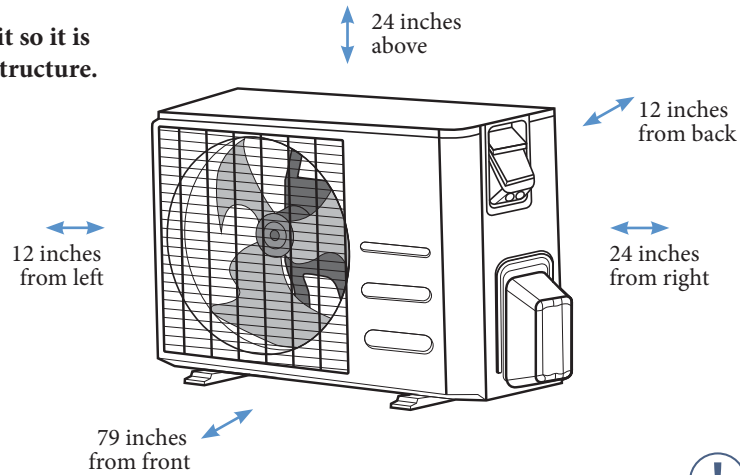

! Maintain listed clearances

Power the Outdoor Unit



- Any high voltage electrical installation should be performed by an electrician or contractor.
- Make sure the electricity is off.
- Follow all local and national electrical codes.
- Always verify line and load lug locations on the disconnect prior to wiring.
- Hot, hot, ground, no neutral is used.

34

Using correct size breaker and wire, run the power to the disconnect box mounted beside the outside unit.

- Connect the indoor unit to the outdoor unit.
- Connect the outdoor unit to the disconnect box with the electrical whip.

! See next page for wiring diagrams

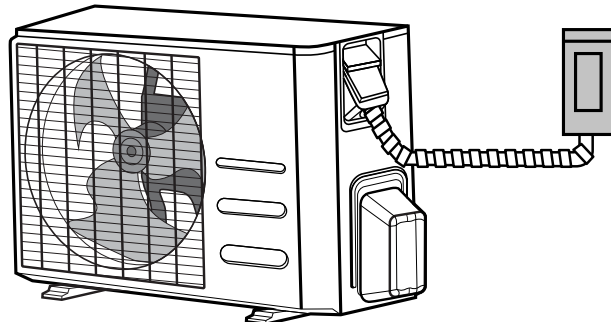

Power the Outdoor unit Unit

35

Power the Outdoor Unit.

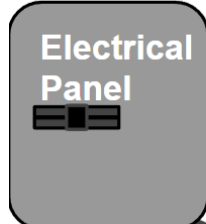

Incoming power to the disconnect:

- Black to Line 1
- Red to Line 2
- Bare wire to ground.

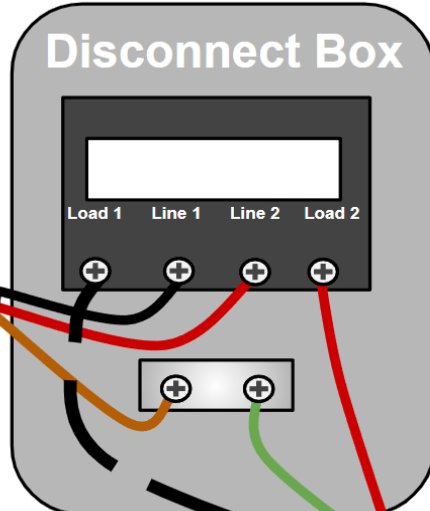

- Whip to the disconnect:
- Black to Load 1.
- Red to Load 2.
- Green to ground

Disconnect to the outdoor unit:

- Black to (1)L1
- Red to (2)L2
- Green to a ground screw

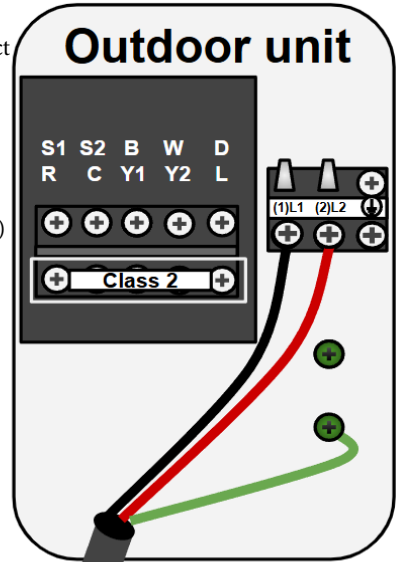

- Wiring is shown based on the disconnect box terminals labeled load, line, line, load.
- Hot, hot, ground, no neutral is used.

36

Connect S1 and S2 Communication.

Only connect low voltage wiring to the S1 and S2 terminals.

No other low voltage wiring at the outdoor unit is supported by the manufacturer.

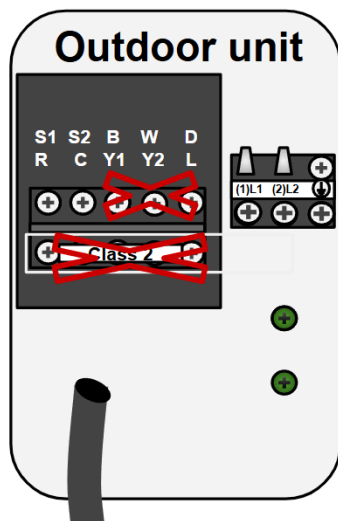

18/2 stranded shielded wire Black to S1, Red to S2, Ground to a ground screw on the outdoor unit.

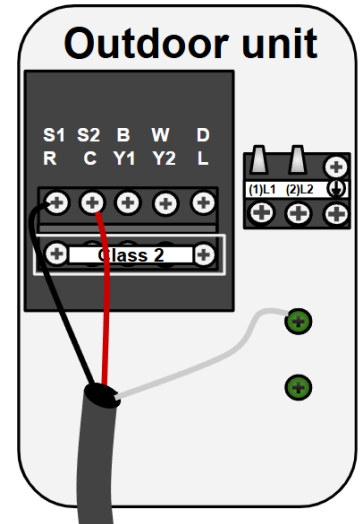

REFRIGERANT | INDOOR UNIT

37

Remove caps from the line set connections on air handler.

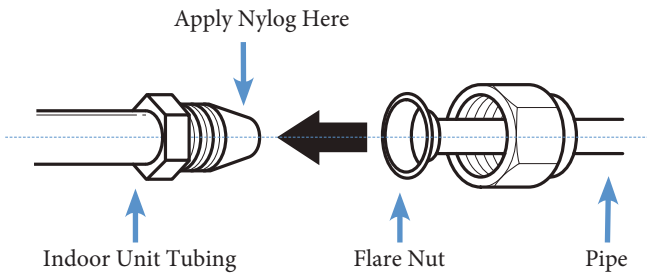

Apply a couple of drops of Nylog sealant to the male side of the flare connection.



Warning: Refrigerant handling should be done by a trained professional.

38

Connect the additional length of line set to the line set on the back of the indoor unit.

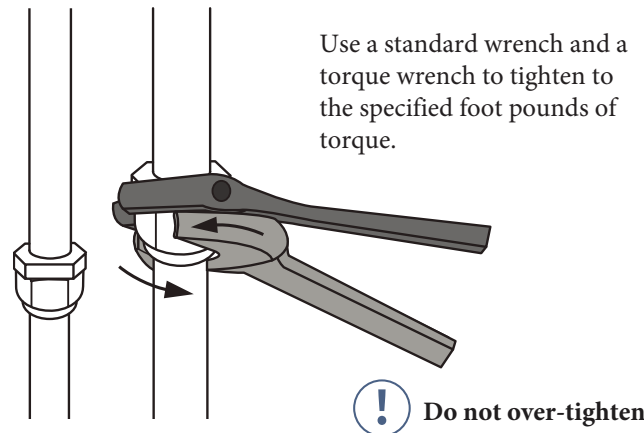

REFRIGERANT | OUTDOOR UNIT

39

Remove caps from the outdoor unit.

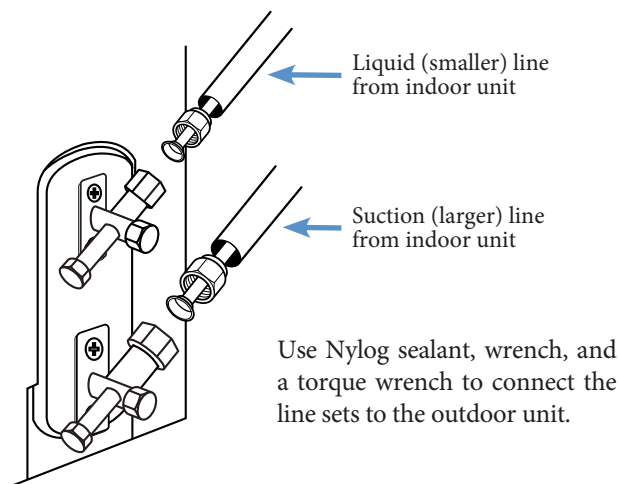

40

Remove cap from the service port on the suction line and perform a pressure test to 300 - 350 psi from the outdoor unit.

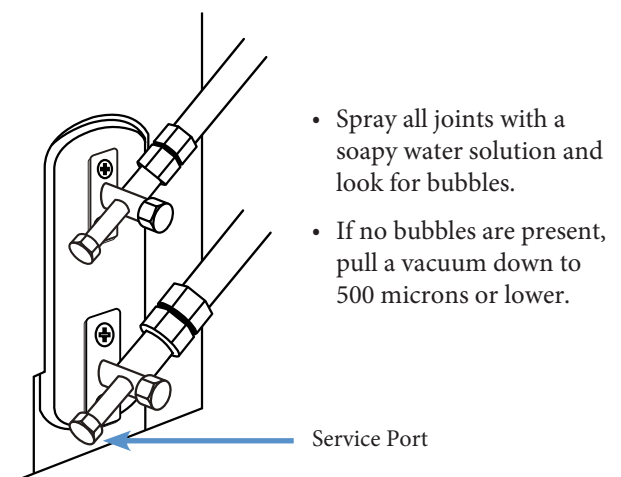

Warning: Refrigerant handling should be done by a trained professional.

41

After creating the vacuum, close the valves to the vacuum pump.

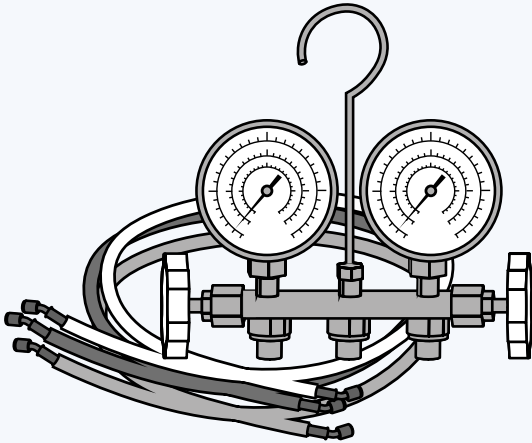

Add refrigerant if the line set used is more than 25 feet in length.

- Add 0.69 oz per foot past 25 feet.

42

Open horizontal facing valve caps.

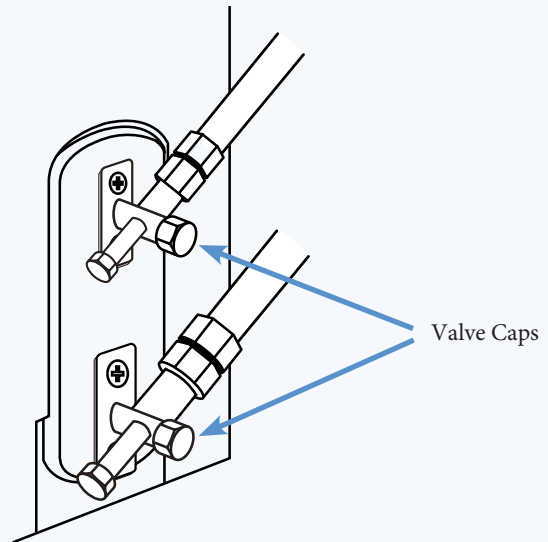

- Use a 5mm allen wrench (hex key) to fully open the lower and then upper valve, releasing the refrigerant into the system.
- Replace caps over the open valves.

43

Power up and start the system.

Please call 1.800.865.5931 if you have any questions prior to or during the installation process of your Blueridge System.

Because of the Blueridge promise for continuous product innovation and improvement, some specifications and instructions may change without notification.