

## BMKH12MFCC SPECS

### Split Air Conditioner Indoor Unit

	Spec	Unit	Value
1	<b>Model</b>	—	<b>BMKH12MFCC</b>
2	<b>Type</b>	—	<b>Floor ceiling air handler</b>
3	<b>Tonnage</b>		<b>1</b>
4	<b>Base Capacity</b>	<b>Btu/h</b>	<b>12000</b>
5	<b>CFM(H, MH, ML, L)</b>	<b>CFM</b>	<b>412 /359 / 318 /247</b>
6	<b>Sound Level (H, MH, ML, L)</b>	<b>dB (A)</b>	<b>38 / 35 / 30 / 26</b>
7	Cooling Power Input	kW	0.04
8	Heating Power Input	kW	0.04
9	Cooling Current Input	A	0.17
10	Heating Current Input	A	0.17
11	Dehumidifying Volume	L/h	1.4
12	Dehumidifying Volume	Pint/h	2.96
13	Rated Voltage	V	208/230
14	Rated Frequency	Hz	60
15	Phases		1
16	Gas (Suction) Pipe	in	1/2
17	Liquid pipe	in	1/4
18	Connection method	—	Flare Connection
19	Drain Connection (outer diameter)	in	<b>5/8 inch</b>
20	<b>Dimensions of the air handler(W×D×H)</b>	<b>in</b>	<b>34.25×9.25×26.18</b>
21	Dimensions of Package(L×W×H)	in	40.66×30.31×11.81
22	Unit Weight	lbs	55.12
23	Gross Weight (with packaging)	lbs	66.14
24	Motor Full Load Amp(FLA)	A	0.28
25	Fan Motor Drive Type	—	Direct
26	Fan Motor Speed	rpm	790/690/610/480
27	Fan Motor Power Output	W	15
28	Fan Motor Power Input	W	38

## Dimensions

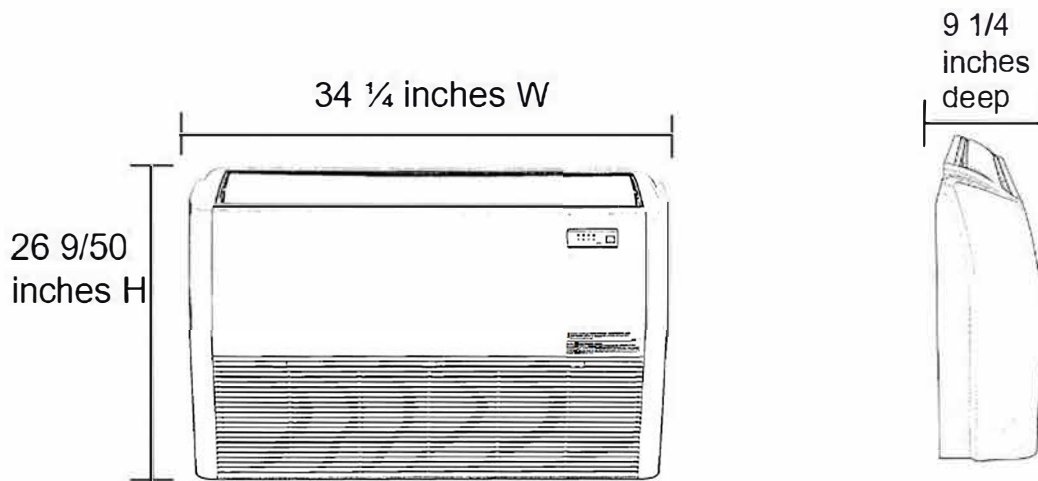

## Clearances

