



Owner's Manual

Original Instructions

R32 Unitary Split Heat Pump

Models:

Outdoor Unit

BNG3Z18UCN

BNG3Z36UCN

BNG3Z60UCN

Thank you for choosing this product. Please read this Owner's Manual carefully before operation and retain it for future reference.



Installer Responsibility

Installation must be performed by qualified personnel in accordance with this manual and all applicable local, state, and national codes and regulations. The installer is responsible for verifying that the equipment is properly sized, the installation location is suitable, and all electrical and refrigerant connections comply with applicable codes. Improper installation may result in equipment damage, personal injury, or voiding of warranty.

To Users

Thank you for selecting this product. Please read this manual carefully before installing or operating the unit. In order to help you install and use your product properly and achieve the expected performance, please note the following:

- (1) This appliance is not intended for use by persons (including children) with reduced physical, sensory, or mental capabilities, or those who lack the necessary experience and knowledge — unless they have been given supervision or instruction by a person responsible for their safety. Children should be supervised to ensure they do not play with the appliance.
- (2) To maintain reliable system operation, the product may consume a small amount of standby power to keep system communications active and to pre-heat the refrigerant and lubricant. If the unit will not be used for an extended period, disconnect the power. When bringing the unit back into service after a long shutdown, reconnect power and allow the unit to pre-heat before operating.
- (3) Select the correct model for your installation environment. Using an incorrectly sized or rated model may affect performance and convenience.
- (4) This product must not be installed in corrosive, flammable, or explosive environments, or in locations with special requirements such as a kitchen. Doing so may affect normal operation, shorten the unit's service life, or cause fire or serious injury. For such locations, use a specially rated unit with corrosion-resistant or explosion-proof construction.
- (5) If the product needs to be installed, relocated, or serviced, contact your authorized dealer or local service center for professional assistance. Do not attempt to disassemble or repair the unit yourself — doing so may cause damage, and the manufacturer will not accept responsibility for any resulting issues.
- (6) All illustrations and information in this manual are provided for reference only. As part of our commitment to continuous product improvement, specifications are subject to change. In the event of any discrepancy, the actual product takes precedence.

Limitation of Liability

The manufacturer accepts no responsibility for personal injury or property damage caused by any of the following:

- Damage resulting from improper use or misuse of the product.
- Unauthorized modifications, changes, repairs, or use in combination with other equipment that does not comply with the manufacturer's instructions.
- Defects confirmed to be caused directly by corrosive gas.
- Damage confirmed to have resulted from improper handling during transportation.
- Operation, repair, or maintenance performed in a manner inconsistent with this manual or applicable regulations.
- Issues or disputes confirmed to be caused by the quality or performance specifications of parts manufactured by third parties.
- Damage caused by natural disasters, adverse environmental conditions, or other acts of god.

Contents

1 Safety Precautions	1
2 Product Introduction	6
2.1 Operating Range	6
2.2 Standard Accessories	6
3 Installation	6
3.1 Installation Preparation	6
3.2 Unit Installation	11
3.3 Electrical Installation	21
3.4 Check after Installation	26
3.5 Test Running	27
4 Maintenance	28
4.1 Failures Not Caused by Faults of the AC	28
4.2 Error Code	30
4.3 Unit Maintenance	32
4.4 Notice on Maintenance	34
5 Qualification of Worker	38
6 Transportation, Marking and Storage for Units that Employ Flammable Refrigerants	39
6.1 General	39
6.2 Transport of Equipment Containing Flammable Refrigerants	39
6.3 Marking of Equipment Using Signs	39
6.4 Disposal of Equipment Using Flammable Refrigerants	39
6.5 Storage of Equipment / Appliances	40
6.6 Storage of Packed (Unsold) Equipment	40
7 Information on Servicing	40
7.1 General	40

7.2 Checks to the Area	40
<u>7.3 General Work Area</u>	<u>40</u>
7.4 Checking for Presence of Refrigerant	40
7.5 Presence of Fire Extinguisher	41
7.6 No Ignition Sources	41
7.7 Ventilated Area	41
7.8 Checks to the Refrigerating Equipment.....	41
7.9 Checks to Electrical Devices.....	42
7.10 Pipe Installation	42
8 Sealed Electrical Components shall be Replaced.....	43
9 Intrinsically Safe Components must be Replaced	43
10 Cabling.....	43
11 Detection of Flammable Refrigerants	43
12 Removal and Evacuation.....	44
13 Charging Procedures.....	45
14 Decommissioning	45
15 Labelling	46
16 Recovery.....	47

1 Safety Precautions

⚠ WARNING

This product must not be installed in corrosive, flammable, or explosive environments, or in locations with special requirements such as a kitchen. Failure to observe this requirement may affect normal operation, shorten the unit's service life, or cause fire or serious injury. For such environments, use a specially rated unit with corrosion-resistant or explosion-proof construction.

Improper installation, adjustment, alteration, service, maintenance, disposal, or use can cause explosion, fire, electric shock, or other conditions that may result in death, personal injury, or property damage. Consult a qualified installer, service agency, or your distributor for information or assistance. Qualified installers must use only factory-authorized kits and accessories when modifying this product. Refer to the individual instructions packaged with any kits or accessories.

Follow all safety codes. Wear safety glasses, protective clothing, and work gloves. Use a quenching cloth for brazing operations. Keep a fire extinguisher nearby. Read these instructions thoroughly and follow all warnings and cautions included in this manual and attached to the unit.

Consult local building codes and the National Electrical Code (NEC) for special requirements. In Canada, refer to the current edition of the Canadian Electrical Code CSA C22.1.

⚠ DANGER

Indicates a hazardous situation that, if not avoided, will result in death or serious injury.

⚠ WARNING

Indicates a hazardous situation that, if not avoided, could result in death or serious injury.

⚠ CAUTION

Indicates a hazardous situation that, if not avoided, may result in minor or moderate injury.

NOTICE

Indicates important but not hazard-related information, used to indicate risk of property damage.



R32 Flammable Refrigerant Information

This appliance is filled with flammable refrigerant R32 (Safety Group A2L).



Read the installation manual before installing this appliance.



Read the owner's manual before operating this appliance.



Read the service manual before performing any repairs on this app

⚠ WARNING

Do not use any method to accelerate the defrosting process or to clean the unit other than methods recommended by the manufacturer.

The appliance must be stored in a room without continuously operating ignition sources (for example: open flames, an operating gas appliance, or an operating electric heater).

Do not pierce or burn the unit.

Be aware that R32 refrigerant is odorless — a refrigerant leak may not be detectable by smell alone.

⚠ WARNING

ELECTRICAL SHOCK HAZARD: Failure to follow this warning could result in personal injury or death. Before installing, modifying, or servicing the system, the main electrical disconnect switch must be placed in the OFF position. There may be more than one disconnect switch. Lock out and tag the switch.

⚠ WARNING

(1) The air conditioner must be properly grounded to prevent electric shock. Do not connect the ground wire to a gas pipe, water pipe, lightning rod, or telephone line.

(2) The appliance must be stored and operated in a well-ventilated area where the room size corresponds to the minimum room area specified for safe operation.

(3) The appliance must be stored in a room without continuously operating open flames (such as a gas appliance) or ignition sources (such as an electric heater).

(4) All packaging and transportation materials — including nails, metal or wooden parts, and plastic packaging — must be disposed of safely in accordance with applicable federal, state, and local regulations.

R32 Unitary Split Heat Pump

- (5) Handle the equipment carefully during transportation. Team lifting may be required; use appropriate lifting equipment. Do not grasp packaging straps. Wear protective gloves during unpacking and handling to prevent injuries from heat exchanger fins or sharp edges. Do not lift the unit by the bottom edge, as this may cause pinched fingers.
- (6) Installation must be performed in accordance with NEC and CEC requirements by authorized personnel.
- (7) Any person who works on or opens a refrigerant circuit must hold a current, valid certification from an industry-accredited authority confirming their competence to handle refrigerants safely in accordance with recognized industry standards.
- (8) Servicing must only be performed as recommended by the equipment manufacturer.
- (9) The appliance must be installed in accordance with national wiring regulations.
- (10) The fixed wiring connected to the appliance must include an all-pole disconnection device rated for Voltage Category III, in accordance with wiring rules.
- (11) The air conditioner should be protected against accidental mechanical damage during storage.
- (12) If the pipe installation space is too small, take protective measures to prevent the piping from sustaining physical damage.
- (13) During installation, use only the specified accessories and components. Using incorrect accessories may cause water leaks, electric shock, or fire.
- (14) Install the air conditioner only on a surface capable of safely supporting its weight. An insecure installation may cause the unit to fall and result in injury.
- (15) Use a dedicated, independent power circuit for this unit. If the power cord is damaged, it must be replaced by the manufacturer, a service agent, or another qualified professional.
- (16) The air conditioner may only be cleaned after the power has been turned off and disconnected — otherwise electric shock may occur.
- (17) This air conditioner is not intended to be cleaned or maintained by children without adult supervision.
- (18) Do not alter the settings of any pressure sensor or protective device. If protective devices are bypassed or modified, fire or explosion may occur.
- (19) Do not operate the air conditioner with wet hands. Do not wash or splash water on the unit — this may cause malfunction or electric shock.

(20) Do not dry the air filter using an open flame or air blower, as this may deform the filter.

(21) If the unit is installed in a small space, take protective measures to prevent refrigerant concentration from exceeding allowable safety limits. Excess refrigerant accumulation may create an explosion hazard.

(22) When installing or reinstalling the unit, ensure that no substances other than the specified refrigerant (such as air) enter the refrigerant circuit. The presence of foreign substances may cause abnormal pressure, system failure, or explosion, resulting in injury.

(23) The heat pump and a furnace must not operate in heating mode at the same time, as this may cause a safety failure.

(24) All external cables must be protected by insulated conduit with additional insulation. The electrical insulation strength between power cables and signal cables must be $\geq 2,750$ V.

(25) To prevent electric shock, do not touch electrical components immediately after disconnecting power. Always wait at least 10 minutes before handling electrical components.

(26) HVAC system failure during cold weather may cause pipes to freeze and burst.

(27) When installing or moving the unit, use only the refrigerant specified on the nameplate. Mixing refrigerants or introducing air into the system may cause refrigeration cycle failure, protection system faults, and serious damage. Leak detection additives must not be used, as they may damage the unit when mixed with refrigerant.

(28) Do not perform brazing inside the unit cabinet.

NOTICE

(1) Do not insert fingers or other objects into the air inlet or return air grille.

(2) Use appropriate protective measures before touching refrigerant pipes. Direct contact without protection may cause injury.

(3) Install the drain pipe according to the instructions in this manual.

(4) Never stop the air conditioner by cutting power directly — always use the proper shutdown procedure.

(5) Select the correct copper pipe size according to the diameter requirements specified in this manual.

(6) Never install the air conditioner in the following locations:

- a) Areas with oil smoke or volatile liquids, where plastic parts may deteriorate and fall off or water leaks may occur.
- b) Areas containing corrosive gases, where copper piping and welds may corrode and cause refrigerant leaks.

(7) Take appropriate measures to protect the outdoor unit from small animals, which may damage electrical components and cause unit malfunctions.

NOTICE

(1) If a thermostat is used, it must be connected before the unit is powered on — otherwise the thermostat may not function.

(2) Clean the unit casing only with a soft, dry cloth or a slightly damp cloth with a neutral detergent. Never use combustible cleaning agents, as they may cause fire or deform components.

(3) Before operating the unit in low-temperature conditions, apply power for at least 8 hours to preheat the unit. If the unit is shut down for a short period (for example, overnight), do not disconnect power, as this protects the compressor.

(4) To protect the compressor, the unit forces the compressor to run for a minimum of 6 minutes each time it starts, regardless of the room temperature. To prevent the indoor unit from being shut off by the thermostat while the outdoor unit is still running, select a thermostat that supports a minimum compressor run time, or allow a few minutes of delay before turning off the indoor unit after the outdoor unit has shut down.

(5) To prevent abnormal operation caused by high pipe temperatures, do not use gas-assisted heating while the outdoor unit is running.

(6) Because the cut-off valve is welded during manufacturing, there is a risk that heat during field pipe welding may damage the O-ring seal in the cut-off valve. When welding the connecting pipe, wrap the cut-off valve body with a wet cloth to protect it from heat.



(7) This product must not be used in combination with incompatible equipment or accessories, as doing so may cause performance, reliability, or safety issues.

(8) HVAC systems may experience operational disruptions due to electromagnetic interference (EMI), which can affect medical devices and broadcast signal transmissions. Conversely, variable-frequency drives (VFDs), dedicated generators, high-frequency medical devices, and radio communication equipment may also interfere with HVAC system operation.

2 Product Introduction

—	Cooling	Heating
Outdoor Temperature	5°F(-15°C)~129.2°F(54°C)	-22°F(-30°C)~75.2°F(24°C)

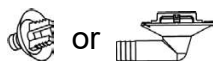
2.2 Standard Accessories

Outdoor unit accessories				
No.	Name	Appearance	Q'ty	Usage
1	Drain plug		3 or 4 with (BNG3Z60UCN)	To plug the unused drain hole
2	Drainage connector	 or 	1	To connect with the hard PVC drain pipe

3 Installation

3.1 Installation Preparation

3.1.1 Selecting the Installation Location

△ WARNING

- (1) The unit must be installed on a surface strong enough to support its weight and secured properly. An insecure installation may cause the unit to tip over or fall.
- (2) The mounting bracket must remain structurally sound for the entire service life of the installation. Any deterioration must be repaired immediately. Failure to do so may cause the equipment to detach, resulting in personal injury or property damage.
- (3) Install the air conditioner on a surface that is level within 5°.
- (4) Do not install the unit in any location where combustible gas could leak.
- (5) Do not install the unit in an area with a risk of flammable gas leakage.
- (6) All equipment panels, protective shields, and safety components must be properly installed before startup. Failure to do so may result in personal injury.

Location selection guidelines for the outdoor unit — select a location that meets the following conditions:

- The noise and airflow produced by the outdoor unit will not disturb neighbors.
- The location is safe and away from animals and plants. If this is not possible, install a protective fence around the unit.
- The location has good ventilation. Ensure there are no obstacles near the outdoor unit that could block the air inlet or outlet.
- The location can support the weight and withstand the vibration of the outdoor unit, and allows the installation to be performed safely.
- Avoid locations with flammable gas leaks, oil smoke, or corrosive gas.
- Keep the unit away from areas subject to strong winds, which can reduce outdoor fan airflow and degrade performance.
- Keep the unit away from any object that could amplify vibration-related noise.
- Install the outdoor unit in a location where condensate can be easily and safely drained.

3.1.2 Unit Dimensions BNG3Z18UCN / BNG3Z36UCN

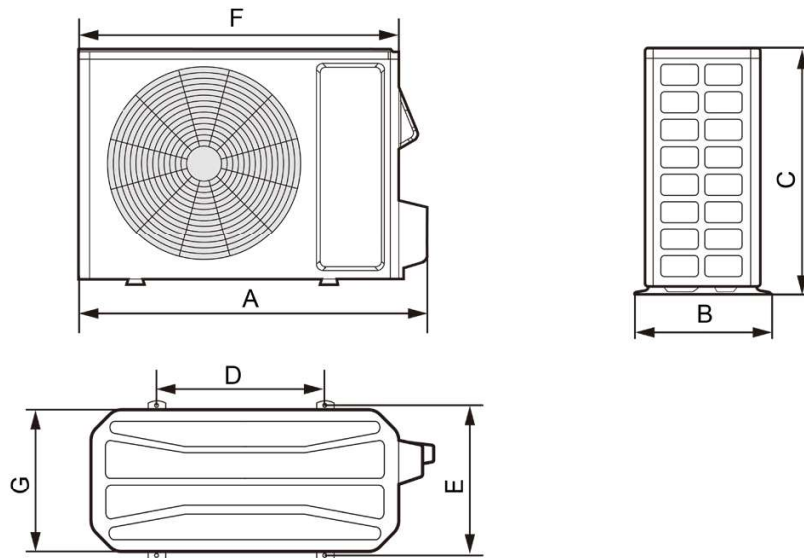

Unit: inch(mm)

Dimensions	A	B	C	D	E	F	G
Model							
BNG3Z18UCN	39-3/8 (1000)	16-13/16 (427)	29-3/8 (746)	24 (610)	15-9/16 (396)	36-1/4 (920)	14-9/16 (370)
BNG3Z36UCN	42-1/16 (1068)	16-13/16 (427)	37-13/16 (960)	29-3/4 (755)	15-9/16 (396)	39 (990)	14-9/16 (370)

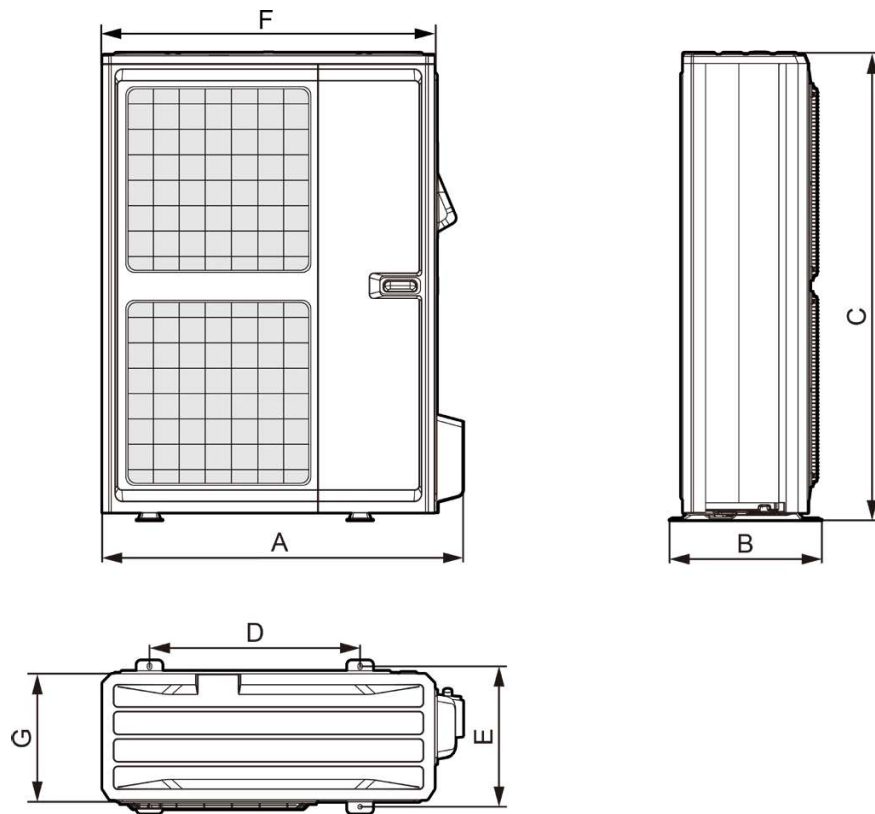

Unit: inch(mm)

Model \ Dimensions	A	B	C	D	E	F	G
BNG3Z60UCN	38-1/2 (978)	16-1/4 (412)	49-5/8 (1260)	22-7/16 (570)	14-7/8 (378)	35-7/16 (900)	13-3/8 (340)

NOTICE

Compatible indoor unit models can be found on the AHRI website.

This unit is equipped with a built-in refrigerant leak detection system. For the leak detection system to function correctly, the unit must remain electrically powered at all times after installation, except during servicing.

This unit also includes electrically powered safety features. For these safety measures to operate properly, the unit must remain powered at all times after installation, except when servicing is being performed.

3.1.3 Required Installation Clearances

To ensure best performance, the outdoor unit must have adequate clearance on all sides. Required minimum clearances depend on the type and height of surrounding obstructions. The diagrams below illustrates the needed clearances.

1) Single outdoor unit — minimum clearances:

1) When one outdoor unit is to be installed.

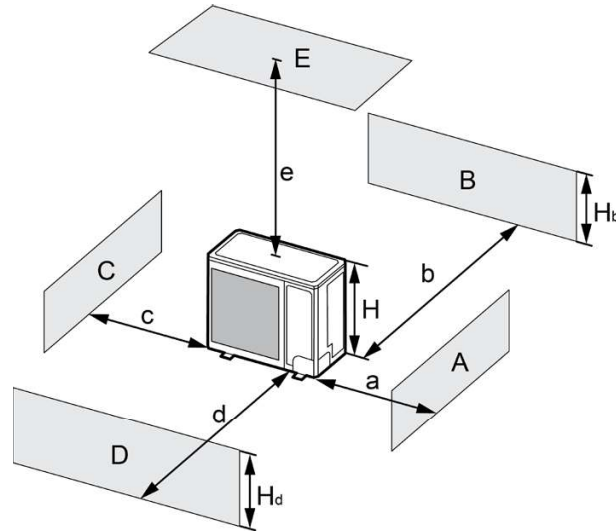

A~E	H _b	H _d	H	(mm)				
				a	b	c	d	e
B	—	—	—	—	≥100	—	—	—
A,B,C,	—	—	—	≥300	≥100	≥100	—	—
B,E	—	—	—	—	≥100	—	—	≥1000
A,B,C,E	—	—	—	≥300	≥150	≥150	—	≥1000
D	—	—	—	—	—	—	≥1000	—
D,E	—	—	—	—	—	—	≥1000	≥1000
B,D	H _b < H _d	H _d > H	—	—	≥100	—	≥1000	—
	H _b > H _d	H _d < H	—	—	≥100	—	≥1000	—
B,D,E	H _b < H _d	H _b ≤ 1/2H	—	≥250	—	≥2000	≥1000	
		1/2H < H _b ≤ H	—	≥250	—	≥2000	≥1000	
		H _b > H	Prohibited					
	H _b > H _d	H _d ≤ 1/2H	—	≥100	—	≥2000	≥1000	
		1/2H < H _d ≤ H	—	≥200	—	≥2000	≥1000	
		H _d > H	Prohibited					

2) When two or more outdoor units are to be installed side by side.

Unit: mm

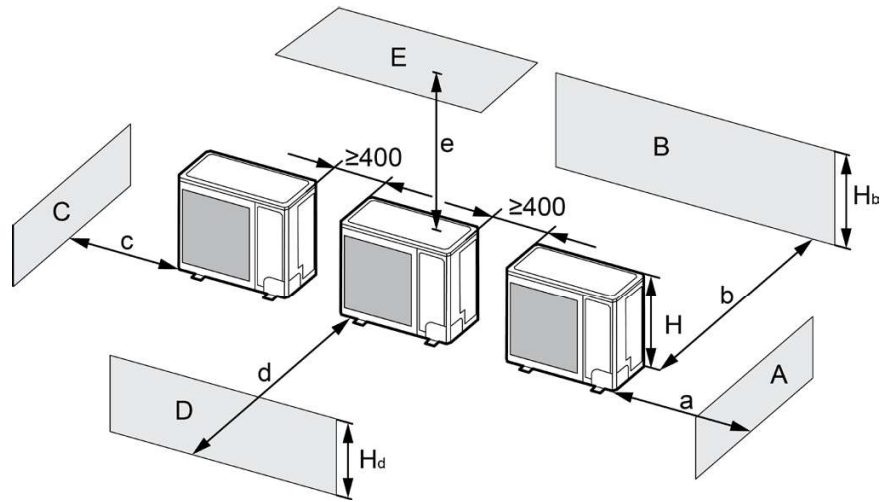

A~E	H _b H _d H		(mm)				
			a	b	c	d	e
A,B,C	—		≥ 300	≥ 300	≥ 1000	—	—
A,B,C,E	—		≥ 300	≥ 300	≥ 1000	—	≥ 1000
D	—		—	—	—	≥ 2000	—
D,E	—		—	—	—	≥ 2000	≥ 1000
B,D	H _b < H _d	H _d > H	—	≥ 300	—	≥ 2000	—
		H _d ≤ 1/2H	—	≥ 250	—	≥ 2000	—
	H _b > H _d	1/2H < H _d ≤ H	—	≥ 300	—	≥ 2500	—
B,D,E	H _b < H _d	H _b ≤ 1/2H	—	≥ 300	—	≥ 2000	≥ 1000
		1/2H < H _b ≤ H	—	≥ 300	—	≥ 2500	≥ 1000
		H _b > H	Prohibited				
	H _b > H _d	H _d ≤ 1/2H	—	≥ 250	—	≥ 2500	≥ 1000
		1/2H < H _d ≤ H	—	≥ 300	—	≥ 2500	≥ 1000
		H _d > H	Prohibited				

3) When outdoor units are installed in rows.

Unit: mm

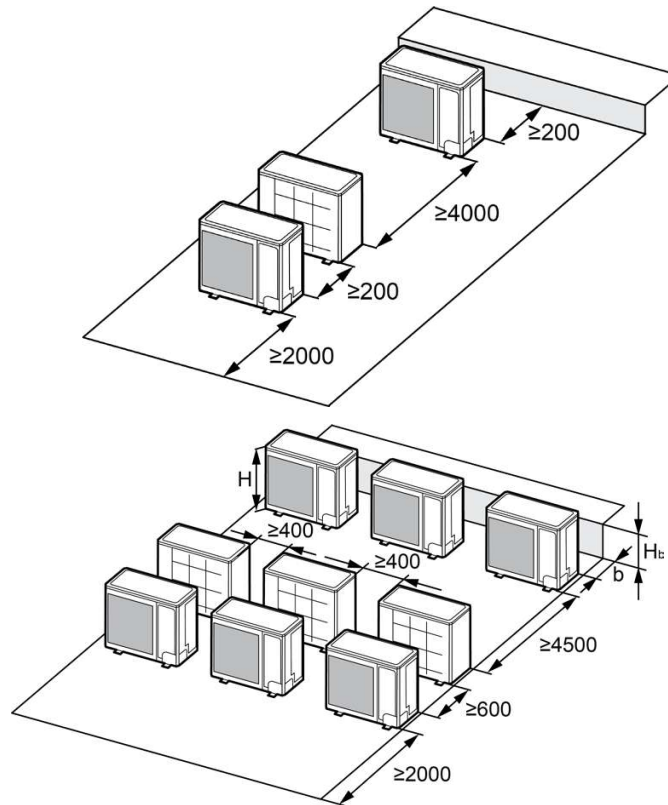

H_b H	(mm)
$H_b \leq 1/2H$	$b \geq 250$
$1/2H < H_b \leq H$	$b \geq 300$
$H_b > H$	Prohibited

3.2 Unit Installation

NOTICE

(1) This outdoor unit does not include a thermal expansion valve (TXV). A throttling valve must be present in the indoor unit (air handler or A-coil). This valve restricts refrigerant flow in cooling mode and opens fully in heating mode. It is included with all matching Blueridge air handlers and evaporator coils.

(2) In areas with frequent snowfall, keep snow cleared away from the unit to prevent it from being buried. Install the unit on a support stand raised above the expected snow depth. Where possible, choose a location that does not accumulate snow drifts. If that is not possible, install a snow guard on top of the unit.

3.2.1 Outdoor Unit Installation

- (1) On a solid foundation such as a concrete pad: use M10 screw bolts and nuts to secure the unit. Ensure the unit stands level and plumb.
- (2) If the unit vibrates and produces noise, place rubber anti-vibration pads between the unit and the mounting base. To reduce the impact of outdoor unit noise, position the unit away from bedroom windows and other noise-sensitive areas.
- (3) When the outdoor unit is in heating or defrost mode, it discharges condensate. To install the drain pipe: insert the included drainage connector into the drainage hole on the outdoor unit chassis, then connect a drain hose to the drainage connector. When a drainage connector is used, the outdoor unit must be elevated at least 10 cm (4 inches) above the ground surface. See the following figures).

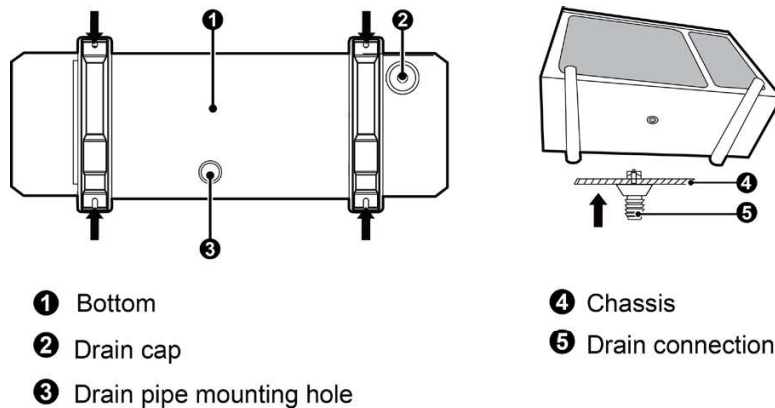

- (4) Do not install the unit in a location where water, ice, or snow falling from an overhang or roof may damage or flood the unit.

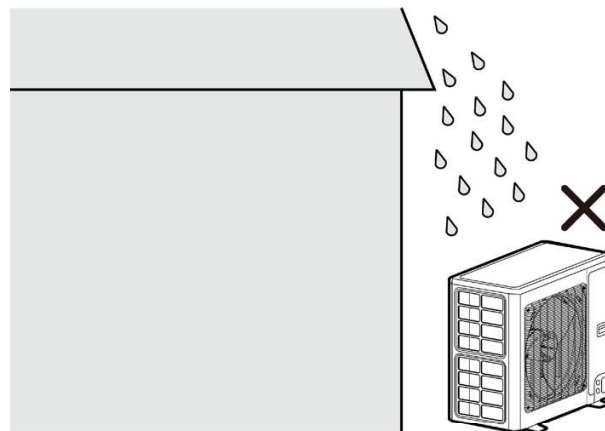

R32 Unitary Split Heat Pump

- (5) Do not install the unit in a corrosive environment — this may shorten service life or degrade performance.
- (6) Installation requirements in snowy areas:
 - 1) Install the air conditioner on a stand which more than 20 in.(500mm) higher than the expected snow fall to prevent it from being covered by snow. Also ensure sufficient height between the bottom of the unit and the foundation level to prevent freezing on the bottom surface of the outdoor unit.
 - 2) Attach snow hood and snow guard, see the following figures.

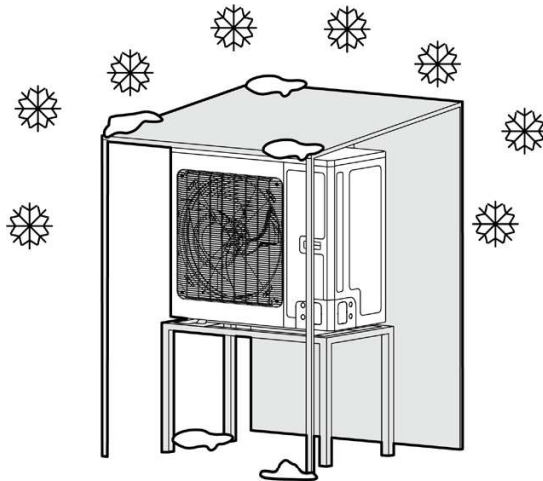

- 3) You can also consult your local dealer to install a dedicated snow cover for the unit, refer to the figure below.

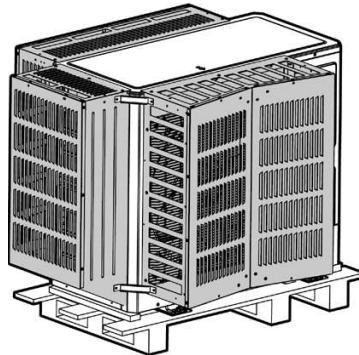

- 4) Do not install the unit in a location prone to snowdrift accumulation.
- 5) Remove the air inlet grille to prevent snow from accumulating on it.
- 6) Do not use drain plugs and drainage connectors in snowy areas; There is a risk of freezing if drain plugs or drain pipes are used.

3.2.2 Connection Pipe Installation

3.2.2.1 Installation Requirements for Connection Pipes

Connect the pipes to the unit carefully. When bending, take care not to collapse the pipe. Do not over-tighten flare nuts — over-tightening will cause leaks. Add insulation to all connection pipes to protect them from mechanical damage during installation, maintenance, and transportation. Before installation, confirm the pipe interior is clean and free of contaminants — any contamination may compromise the unit's operational integrity.

Model \ Item	Size of fitting pipe(inch)		Maximum pipe length feet(m)	Biggest drop between indoor and outdoor units feet(m)
	Liquid pipe	Gas pipe		
BNG3Z18UCN	Φ1/4	Φ1/2	65.6(20)	32.8(10)
BNG3Z36UCN BNG3Z60UCN	Φ3/8	Φ3/4	98.4(30)	49.2(15)

- Connection pipes must use waterproof insulating material. The ends of the insulation must be sealed to maintain effectiveness.
- Refrigerant piping must be copper tubing rated for at least 870 psi (6.0 MPa) pressure with a minimum wall thickness of 0.5–1.0 mm, depending on pipe diameter.
- The longer the connection pipe run, the greater the reduction in heating and cooling performance.

- (1) Cut the connection pipe with a pipe cutter.
- (2) Hold the cut end face-down and remove all burrs from the cut surface so that copper chips cannot enter the pipe.
- (3) Remove the cut-off valve caps from the outdoor unit and retrieve the flare nuts from the indoor unit accessory bag. Fit the flare nut onto the pipe, then use a flaring tool to flare the pipe end.
- (4) Inspect the flared end for cracks before making any connections.
- (5) If replacing the outdoor unit, weld an additional dry filter onto the gas pipe.

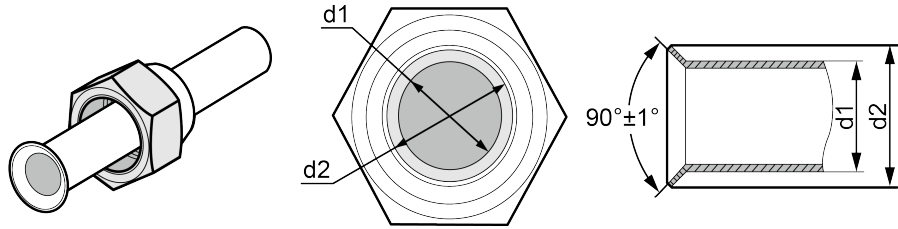

d1 inch	d2 inch(mm)
Φ1/4	Φ11/32-Φ3/8(Φ8.6-Φ9.0)
Φ1/2	Φ19/32-Φ21/32(Φ15.4-Φ16.2)
Φ3/8	Φ1/2-Φ17/32(Φ12.6-Φ13.4)
Φ3/4	Φ15/16-Φ31/32(Φ24.0-Φ24.5)

3.2.2.3 Pipe Bending

(1) When bending the pipes by hand. Take care not to collapse or kink them. (the use of a tubing bender is recommended)

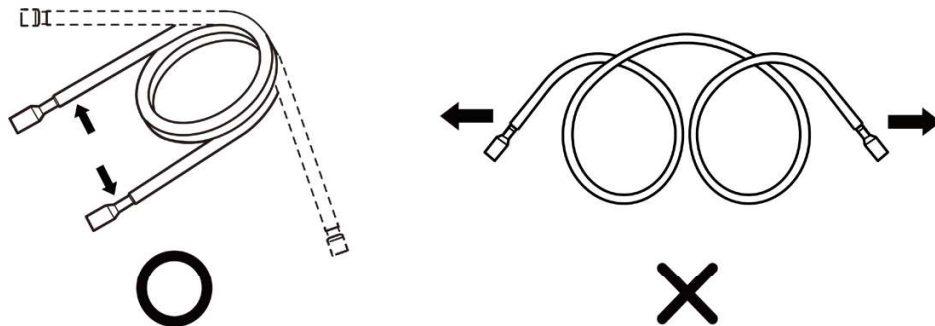

- (2) Do not bend the pipes in an angle more than 90°.
- (3) If the pipe is repeatedly bent or extended, it will become hard and difficult to be bent or extended. So do not bend or straighten the pipe for more than 3 times.
- (4) When bending insulated pipes: use a sharp knife to slit the insulation and expose the bare pipe, make the bend, then replace the insulation over the pipe and secure with adhesive tape

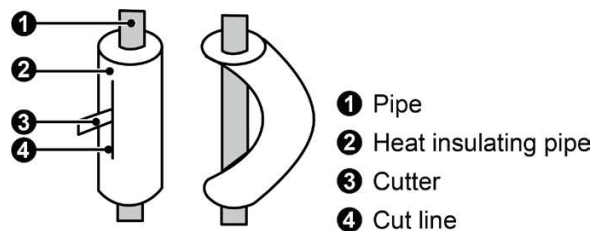

3.2.2.4 Connection Pipe of the Units

NOTICE

- (1) Use both a back-up wrench and a torque wrench when making flare connections.
- (2) Before threading the flare nut, apply a thin coat of Nylog to the inner and outer surfaces of the flare, then hand-tighten 3–4 turns before using the torque wrench.
- (3) Tighten to the torque values specified in the table below. Over-tightening may damage the flare (bell mouth), while under-tightening may cause refrigerant leaks.
- (4) After connecting all pipes, check for refrigerant leaks, then apply thermal insulation.
- (5) Wrap sponge insulation around the joint between the gas pipe and the insulation sleeve of the gas collecting pipe.
- (6) Always connect the liquid pipe before connecting the gas pipe.
- (7) Insulation is required on the gas pipe. Insulation on the liquid pipe is optional.
- (8) All refrigerant lines must be adequately supported.

3.2.2.4.1 Flare Connection

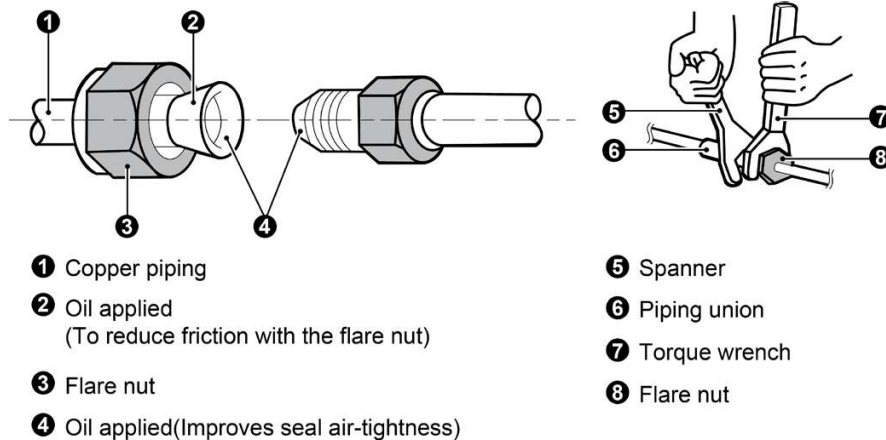

Pipe diameter (inch)	Tightening torque Ft-pounds)
Φ1/4	11.07-22.1
Φ3/8	25.82-29.5
Φ1/2	33.2-36.87
Φ5/8	44.26-47.94
Φ3/4	51.63-55.3
Φ7/8	59-62.69

NOTE: Ensure the pipe is securely connected. Over-tightening may damage the bell mouth, while undertightening may result in refrigerant leakage.

After commissioning is complete, tighten all shut-off valve caps as follows:

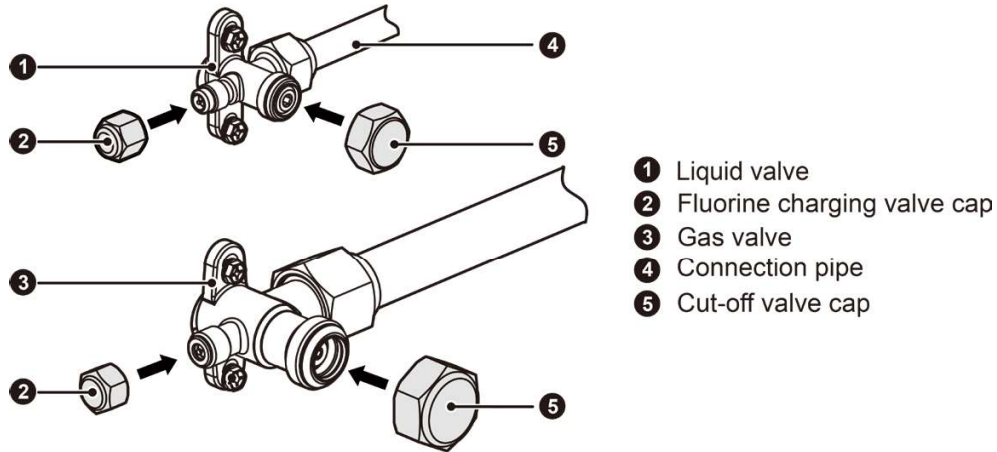

Pipe diameter (inch)	Tightening torque Ft-pounds)	
	Fluorine charging valve cap	Cut-off valve cap
3/8"	5.9-6.26	14.76-15.48
3/4"	5.9-6.26	29.51-30.97

NOTE: When operating the service valve, refrigerant may escape from the gap between the valve stem and body, which can cause personal injury. Use appropriate caution.

3.2.3 Connection Pipe Vacuum Pumping and Leak Detection

NOTICE

- (1) Ensure the vacuum pump exhaust is directed away from any ignition sources and into a well-ventilated area
- (2) Confirm that all cut-off valves on the unit are closed before starting the vacuum pump.

- (1) Remove the caps of the liquid valve, gas valve and also the service port.
- (2) Connect the hoses: Low side hose → gas service port (large line)
 High side hose → liquid service port (small line)
 Valves stay closed while connecting hoses
- (3) Connect the center hose of the manifold valve assembly to the vacuum pump. the hose used for evacuation to the vacuum pump.
- (4) Open the low-pressure side switch and start the vacuum pump.
 Keep the high-pressure side switch closed.

(5) The evacuation duration can vary but no less than 45 minutes.

Model	Time(min)
BNG3Z18UCN	30
BNG3Z36UCN	45
BNG3Z60UCN	45

Verify that the vacuum gauge reads 500 microns or lower. If the system cannot reach 500 microns, it may indicate a leak or moisture in the system. Once the target vacuum is reached, close the manifold valves and stop the vacuum pump.

- (6) Wait 10 minutes to verify that the vacuum holds. During this time, the pressure should not rise above 1000 microns. If the vacuum rises above 1000 microns, it may indicate a leak or remaining moisture in the system.
- (7) Slightly open the liquid service valve to allow a small amount of refrigerant into the line set. This equalizes the pressure and prevents air from entering the system when the hoses are removed. Do not fully open the service valves yet. The gas and liquid valves should only be opened.

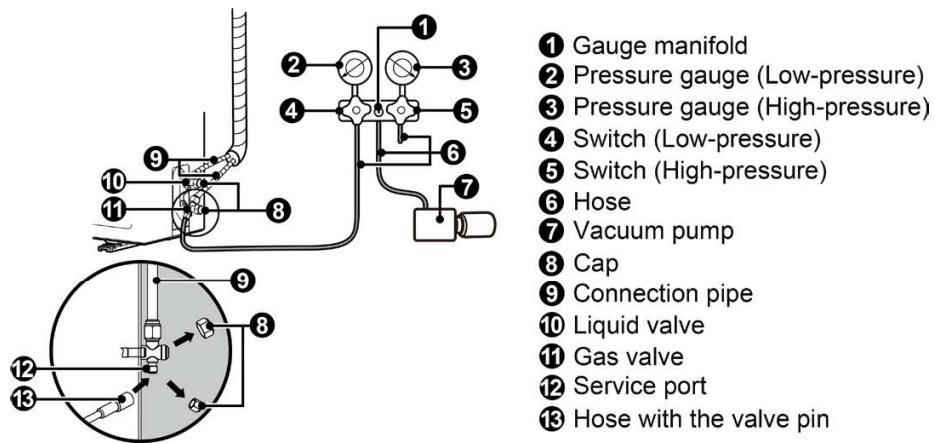

NOTICE

For larger units, the gas and liquid service valves include maintenance ports. During evacuation, connect hoses to both maintenance ports using the manifold gauge set. This allows both lines to be evacuated at the same time and speeds up the evacuation process.

3.2.4 Refrigerant Adding

See the following table for the amount of additional refrigerant.

Model \ Item	Standard pipe length	Unnecessary charge pipe length	Additional refrigerant amount for extra pipe
BNG3Z18UCN	24.6 ft	31.2 ft	0.11 oz/ft
BNG3Z36UCN			0.34 oz/ft
BNG3Z60UCN			0.23 oz/ft

Compliance with applicable national gas regulations is required. All indoor refrigerant joints made on-site must be leak tested after charging. Use leak detection equipment with a sensitivity of 5 g/year or better, tested at a pressure of at least 0.25 times the maximum allowable pressure. No leaks are permitted.

3.2.5 Drain Pipe Installation

3.2.5.1 Outdoor Unit Condensate Drain

Outdoor unit installed below the indoor unit

(see the image on the next page):

- Route the drain hose so that the open end lies at ground level and is not submerged in water. Support and fasten the entire pipeline to the wall.
- Wrap insulating tape around the hose from the bottom upward.
- Secure the entire pipeline to the wall using clamps.

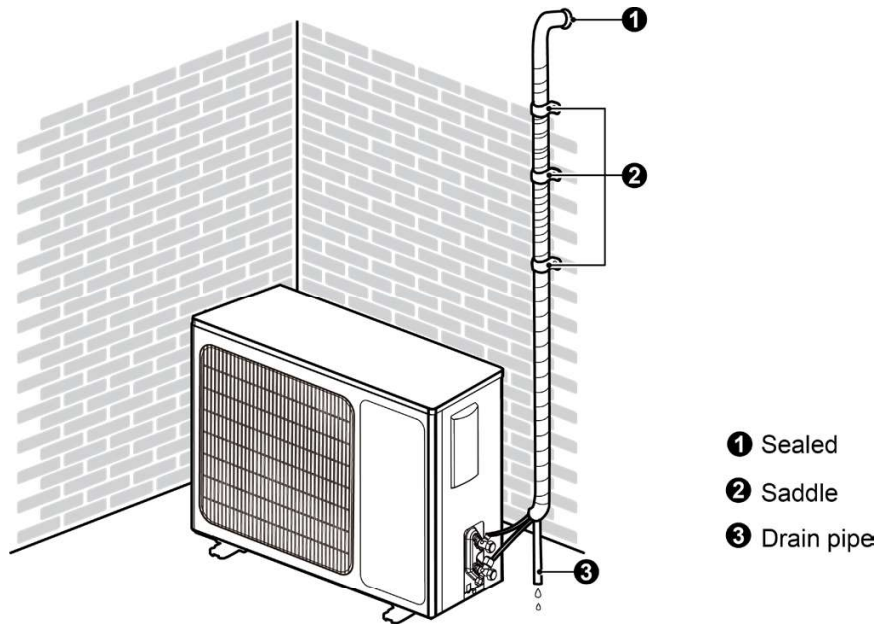

If the outdoor unit is installed above the indoor unit, route the piping as shown in the diagram below.

- 1) Wrap the insulation tape starting at the bottom and work upward.
- 2) Tape the entire line set bundle together to prevent rainwater from entering the building.
- 3) Secure the line set to the wall using clamps.

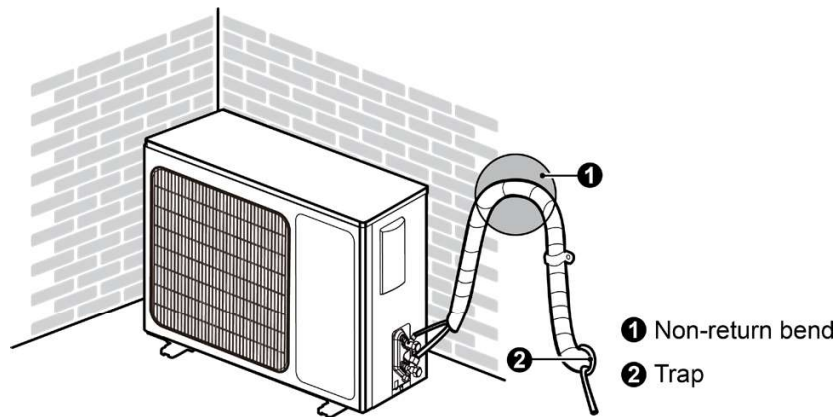

NOTICE

During heating mode, the outdoor unit continuously discharges condensate. Position the drain hose to prevent water from causing structural damage or creating icy hazards on sidewalks or walkways.

3.3 Electrical Installation

3.3.1 Requirement and Notice on Electrical Installation

WARNING

The electrical installation for the air conditioner should observe the following requirements:

- ①. The electrical installation must be conducted by professionals in compliance with local laws and regulations and the instructions in this manual. The electric circuit must be equipped with a circuit breaker and disconnect box both with sufficient capacity.
- ②. The unit's operating power must be within the nominal range stated in the instruction manual. Use a dedicated power circuit for this unit. Do not share a circuit with another load.
- ③. The air conditioner circuit should be at least 5ft away from any flammable surface.
- ④. The external power cords, the communication wires and outdoor unit must be securely fastened.
- ⑤. The external power cords, the communication wires and outdoor unit must not directly contact any hot objects. For example: they must not contact chimney pipes, gas supply pipes or other hot objects.
- ⑥. Do not pinch the power cable or communication wires. Do not pull, stretch, or sharply bend the wiring.
- ⑦. Ensure the power and communication wires do not rub against metal framing, edges, or sharp surfaces.
- ⑧. Connect the wires according to the wiring diagram located on the unit or inside the electrical panel. Tighten all terminal screws securely. If a screw becomes stripped, replace it with the correct type and size.
- ⑨. Make sure all wires are firmly connected to the terminal block. Loose connections are not permitted. All wiring must be firmly secured. Loose terminal connections may result in terminal overheating, leading to equipment failure or fire hazards.

- ⑩. Power supply wires must be sized correctly for the unit. If any power cord or wiring is damaged, it must be replaced with the proper replacement wiring. All wiring must comply with applicable national electrical codes and regulations.
- ⑪. This outdoor unit is equipped with a four-way reversing valve for heating operation.
- ⑫. Wiring must not contact refrigerant lines or any moving parts within the equipment.
- ⑬. Power wiring and communication/signal wiring should be routed separately. Crossing or bundling these wires may cause signal interference (EMI) or damage to the control board.
- ⑭. Power and communication cables should be protected with metal conduit where required to prevent rodent damage or mechanical damage.

3.3.2 Electrical Parameters

Model	Power supply	Fuse capacity (A)	Maximum over-current protection (A)	Minimum circuit ampacity (A)
BNG3Z18UCN	208/230V-1Ph-60Hz	20	20	19
BNG3Z36UCN	208/230V-1Ph-60Hz	30	30	27.7
BNG3Z60UCN	208/230V-1Ph-60Hz	45	45	39.9

NOTE: All wiring must be routed through the provided conduit or protective tube.

3.3.3 Connection of Power Cords and Communication Wires

- (1) For solid conductors:
 - 1) Cut the wire to the required length and strip approximately 25 mm (about 1 inch) of insulation from the end.
 - 2) Loosen the terminal screw on the terminal block. Use nippers to bend the solid wire into a ring that fits the terminal screw.
 - 3) Bend the stripped wire into a hook or ring shape that fits around the terminal screw.
 - 4) Place the wire on the terminal and tighten the screw securely.

- (2) For strand wires (as shown below):
- 1) Cut the wire to the required length and strip about 10 mm ($\approx 3/8$ in.) of insulation from the end.
 - 2) Loosen the terminal screw on the terminal block.
 - 3) Crimp a ring terminal onto the stripped end of the wire using the appropriate crimping tool.
 - 4) Place the ring terminal over the terminal screw and tighten the screw securely. (as shown below).

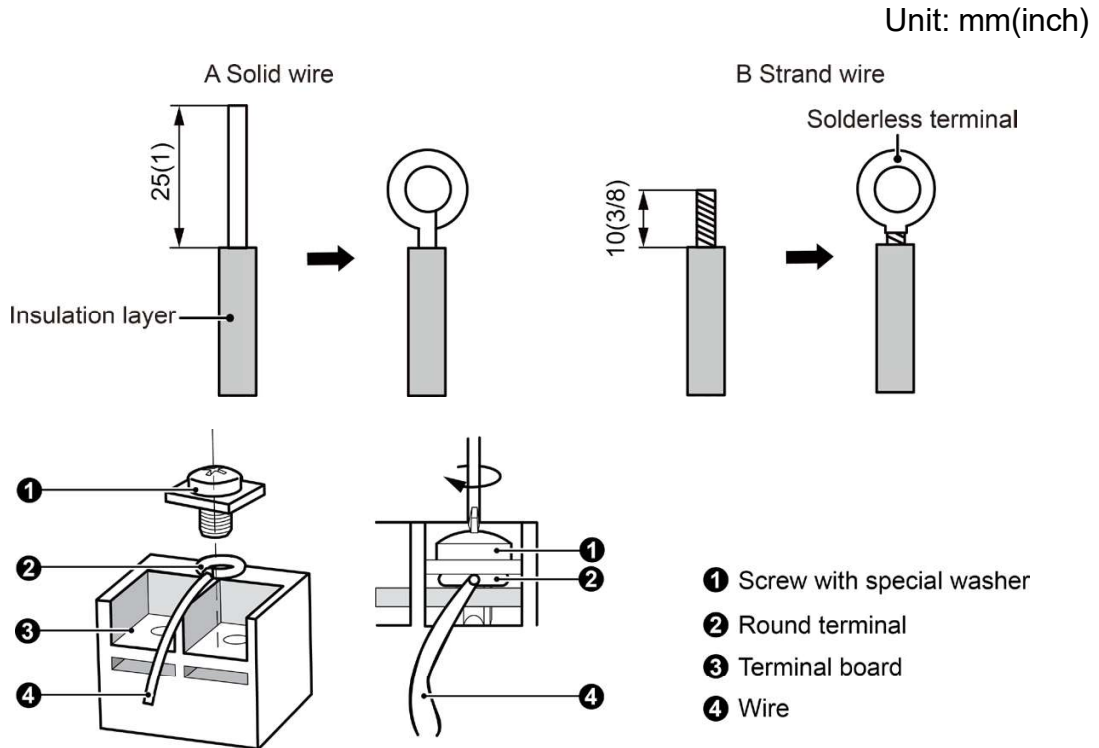

- (3) Connecting the communication wires and power cords.

Before connecting the wires, route the power and communication cables through the protective insulation tube shown in the figure below.

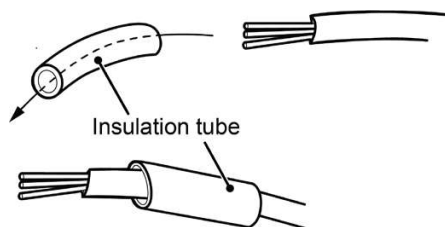

⚠ WARNING

- (1) Before performing any work, make sure the unit power is turned OFF.
- (2) Incorrect wiring may damage electrical components.
- (3) Connect all wires securely to the terminal block. Improper or loose wiring may cause equipment damage or fire.
- (4) The equipment must be properly grounded.

Electrical wiring 1 (Not Applicable for Blueridge units)

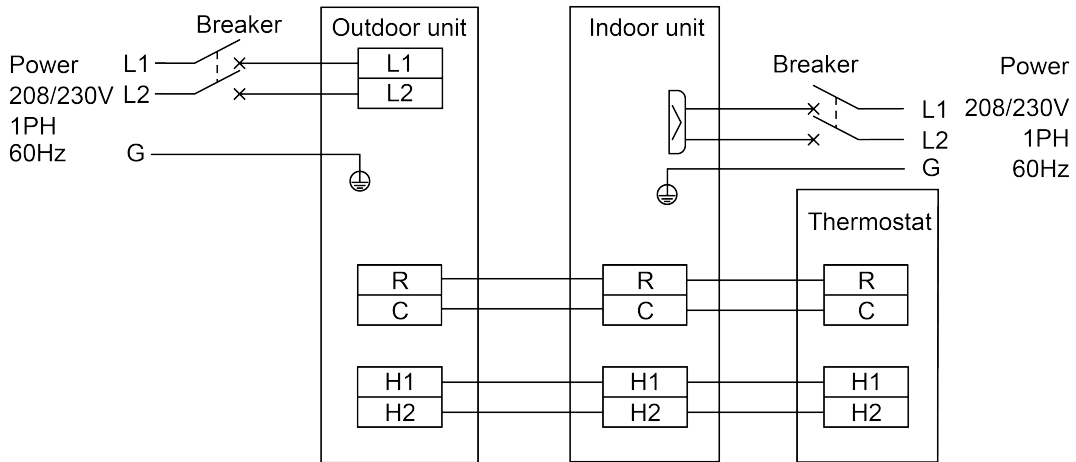

Electrical wiring 2

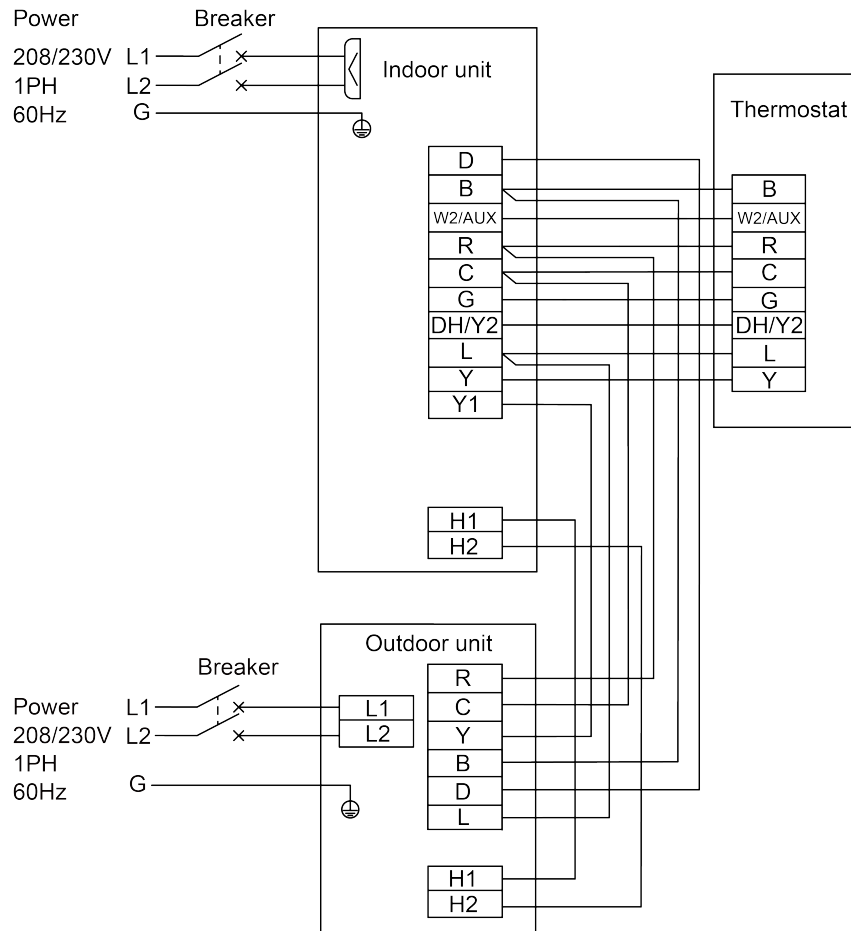

NOTE:

Y – Compressor control signal for the outdoor unit

B – Reversing valve control signal (energized in heating mode)

D – Defrost signal

R – 24V AC power supply

C – 24V common

G – Indoor fan control signal

W2/AUX – Auxiliary heater control signal

L – Refrigerant leak protection signal

DH – Dehumidification signal

Y1 – Primary compressor call

Y2 – High demand / second-stage call

H1 / H2 – RS485 communication terminals

NOTE: For cooling-only units, the B and D terminals do not need to be connected.

NOTE: During defrost, the outdoor unit sends a 24V signal on terminal D to prevent cold air discharge.

NOTE: Terminal L must be connected between the indoor and outdoor units.

NOTE: A circuit breaker must be installed in the fixed wiring in accordance with applicable electrical codes.

NOTE: When installing electric heat, use M6 grounding screws.

NOTE: In the first wiring configuration (Not applicable to Blueridge units), if electric heat is enabled, W2/AUX and R must be jumpered together.

 WARNING
(1) Route the high-voltage power wires and low-voltage communication wires through the designated cable entry openings.
(2) Do not bundle communication wires together with power wires or run them side by side, as this may cause communication errors.
(3) High-voltage and low-voltage wiring must be routed and secured separately.
(4) Connect the power and communication wires to the terminal block and tighten all terminal screws securely. Incorrect wiring may result in equipment damage or fire.
(5) If the power or communication wiring is not connected correctly, the unit may be damaged.
(6) Ensure the unit is properly grounded by connecting the ground wire.

⚠ WARNING

- (7) The units should comply with applicable local and national rules and regulations on power consumption.
- (8) When connecting the power supply wires, ensure the wires are connected to the correct terminals as shown in the wiring diagram. Incorrect wiring may cause the compressor to operate improperly or damage the unit.
- (9) The terminal cover of the outdoor unit must be securely installed. Failure to install the cover properly may allow dust or water to enter the electrical compartment and create a risk of fire or electric shock.

Schematic diagram of the engineering routing:

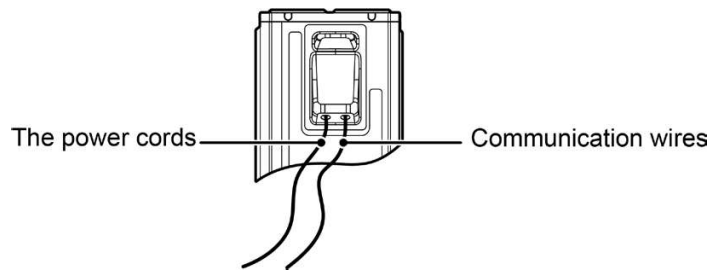

3.4 Check after Installation

Check Items after Installation

Check items	Possible events due to improper installation
Is the unit securely mounted?	The unit may fall, vibrate or produce noise.
Has a refrigerant leak test been performed?	Cooling performance may be reduced.
Are the refrigerant lines properly insulated?	Condensation or water dripping may occur.
Is the condensate drain working properly?	Condensation, water leakage may occur.
Does the supply voltage match the unit nameplate rating?	The unit may fail or its components may get damaged.
Are the wiring and piping installed correctly?	The unit may fail or its components may get burned.
Has the unit been safely grounded?	Risk of electric shock or electrical leakage.
Do the power wires meet the required specifications?	The unit may fail or its components may get damaged.
Are the air inlet and outlet unobstructed?	Cooling performance may be reduced.

Check items	Possible events due to improper installation
Have you recorded the refrigerant line set length and any additional refrigerant added?	The correct refrigerant charge cannot be verified or adjusted.

3.5 Test Run

Preparation before applying power:

- (1) Do not connect power until all installation work has been completed.
- (2) Verify the control wiring is correct and that all electrical connections are secure.
- (3) Confirm the liquid and gas service valves are fully open.
- (4) Inspect the indoor unit and ductwork to ensure they are clean and free of debris. Remove any foreign objects if present.
- (5) After inspection, reinstall the front panel of the unit.

Operation after power is applied:

- After all installation checks above are completed, turn on power to the unit. Do not power the unit until installation is complete.
- If the outdoor temperature is above 30°C (86°F), heating mode will not operate.
- **(If the outdoor temperature is below 40F)** Before starting the test run, leave power on for at least 8 hours so the compressor crankcase heater can warm the compressor. Starting the system without proper preheating may damage the compressor.
- Start the system and confirm the unit operates normally.
- If liquid slugging or abnormal knocking sounds are heard from the compressor, turn the system off immediately. Allow the crankcase heater to warm the compressor, then restart the unit.
- Test operation and system commissioning should be performed by qualified technicians only.
- If you use thermostat to turn off the unit and then immediately turn the unit back on again, the compressor will need 3 min before it restarts.
- If the thermostat display is blank, check that the thermostat wiring between the indoor and thermostat is connected correctly.

4 Maintenance

4.1 Conditions That Are Not System Failures

If the air conditioner does not operate normally, check the following items before requesting service.

Problem	Cause	Corrective measure
The air conditioner will not start	The unit was turned off and immediately turned back on. The compressor has a built-in 3-minute protection delay .	Wait approximately 3 minutes and allow the system to restart.
	Incorrect wiring connection.	Verify wiring according to the wiring diagram .
	Blown fuse or tripped circuit breaker.	Replace the fuse or reset the circuit breaker.
	Power outage.	Restart after power is restored.
	Power plug or electrical connection is loose.	Reconnect the power supply securely.
Poor cooling or heating performance	Air inlet or outlet is blocked.	Remove any obstructions and ensure adequate airflow.
	Improper temperature setting	Adjust the thermostat to a proper temperature.
	Fan speed is too low.	Increase the fan speed setting.
	Airflow direction is incorrect.	Change the direction of air louvers.
	Doors or windows are open.	Close doors and windows.
	Direct sunlight entering the room.	Use curtains or blinds to reduce solar heat gain.
	Excessive heat sources in the room.	Remove unnecessary heat sources.
	Filter is clogged or dirty.	Clean or replace the air filter.

The following situations are not operation failures.

Problem	Time of occurrence	Cause
---------	--------------------	-------

R32 Unitary Split Heat Pump

Mist comes from the air indoor unit.	During cooling operation.	When the unit operates in high humidity , the air leaving the unit may appear as mist. This is normal condensation forming as warm humid air is rapidly cooled.
Problem	Time of occurrence	Cause
Unit makes noise	After defrost, when switching back to heating	During defrost, water on the outdoor coil evaporates and may produce a small amount of vapor.
	The air conditioner is buzzing at the beginning of operation.	A brief buzzing sound may occur when the system starts. This usually becomes quieter after about 1 minute ..
Unit makes noise	Immediately after startup	Refrigerant pressure is stabilizing. The sound typically decreases after about 30 seconds .
	About 20 seconds after heating or defrost begins	This is the four-way reversing valve switching direction . The sound will stop once the valve finishes switching.
	There is hissing sound when the unit is starts or stops.	Refrigerant flow and condensate drainage may produce a brief hissing sound.
	There is a cracking sound during and after operation.	Temperature changes can cause plastic panels or other components to expand or contract , producing cracking sounds.
Dust coming from the unit	There is a hissing sound when the unit is turned on or suddenly stopped during operation or after defrosting.	Refrigerant flow may change direction or stop suddenly, producing a temporary hissing sound.
	The unit starts operation after being unused for a long time.	Dust inside the units come out together with the air.
Odor from the unit	During operation.	Odors from the room (such as smoke, cooking, or other smells) may be circulated through the system.

NOTICE

Check the above items and adopt the corresponding corrective measures. If the air conditioner continues to function poorly, please stop the air conditioner immediately and contact your dealer or call a contractor.

4.2 Error Code

 WARNING	
(1)	If abnormal conditions occur (such as a burning smell), please stop the unit immediately and disconnect power. Then contact our dealer or professional contractor. If the unit continues to operate in abnormal situations, it may result in equipment damage, shock, or fire.
(2)	Do not repair the air conditioner by yourself. Improper repairs may cause electric shock or fire. Please contact our dealer or professional contractor to repair.

If the LED displayer on mainboard of outdoor unit displays an error code, please refer to the table below.

No.	Error code	Error
1	E1	Compressor high pressure protection
2	E3	Refrigerant lack protection or compressor low pressure protection
3	E4	Compressor air discharge high-temperature protection
4	H4	Overload protection
5	C6	Discharge temperature sensor error
6	F3	Outdoor ambient temperature sensor error
7	e1	High pressure sensor error
8	e3	Low pressure sensor error
9	EE	Memory chip reading and writing failure
10	C4	ODU jumper cap error
11	C3	Condenser temperature sensor error
12	C7	ODU tube temperature sensor error
13	H3	Compressor overload protection
14	E2	Indoor Anti-freezing Protection
15	b2	Overcooler Gaseous Inlet Tube Temperature Sensing Error
16	b3	Overcooler Gaseous Outlet Tube Temperature Sensing Error
17	E6	Internal and external machine communication fault
18	H2	IPM Low Temperature Protection
19	FE	Refrigerant sensor fault
20	EH	Protection of auxiliary electric heating by mistake
21	C1	Indoor environment temperature sensing bag fault
22	C2	Indoor tube temperature sensing bag fault

R32 Unitary Split Heat Pump

No.	Error code	Error
23	FJ	Indoor air outlet temperature sensing bag fault
24	CA	Evaporator inlet tube temperature sensing bag fault
25	Cb	Evaporator output tube temperature sensing bag fault
26	CJ	Internal jumper cap fault
27	Ab	Drive reset protection (fan drive)
28	EA	Internal refrigerant leakage protection
29	A6	Fan communication failure (fan drive)
30	A8	Module temperature too high (fan driven)
31	A9	Drive sensor fault (fan drive)
32	Ad	Phase loss protection (fan drive)
33	AH	Bus voltage too high (fan drive)
34	AL	Bus voltage too low (fan drive)
35	C8	Driver jumper cap fault
36	U2	Compressor phase-sequence protection
37	LE	The compressor is locked
38	P6	Communication fault between main control and driver
39	P8	Heat sink or IPM module or PFC module over temperature
40	UL	Over-current protection of frequency conversion external fan
41	PL	Bus low-voltage protection
42	PH	Bus high-voltage protection
43	PA	ODU AC current protection
44	H5	IPM module current protection
45	L3	DC fan error
46	HC	PFC overcurrent protection
47	Lc	Compressor startup failure
48	P0	Driver reset protection
49	P5	Compressor phase over-current protection
50	U1	Current detection circuit fault or current sensor fault
51	H7	Compressor out-of-step protection
52	P7	Module temperature sensor circuit failure
53	PU	Capacitor charging failure
54	A1	Outdoor fan IPM module protection
55	Ac	Outdoor fan startup failure
56	AE	Outdoor fan current detection circuit error

No.	Error code	Error
57	AJ	Outdoor fan out-of-step protection
58	E0	Indoor fan error

4.3 Unit Maintenance

 WARNING
(1) Maintenance and service must be performed by qualified personnel only.
(2) Disconnect power before working on any electrical wiring or components.
(3) Keep flammable materials away from the unit.
(4) Do not use organic solvents to clean the system.
(5) If any components need to be replaced, use only parts supplied or approved by the original manufacturer to ensure proper operation and safety.
(6) Improper operation or servicing may result in equipment damage, electric shock, or fire.
(7) Never clean the unit by spraying or rinsing it with water, as this may cause electrical shock or equipment damage
(8) Keep ventilation openings and airflow paths free of obstructions.
(9) Avoid routing refrigerant piping through locations where ignition sources may be present, such as gas appliance burner compartments or electrical panels.
(10) For appliances using A2L refrigerant connected to one or more rooms via a duct system, the supply and return air should be directly piped to the space. Open areas such as ceilings should not be used as return air ducts;
(11) Precautions should be taken to avoid excessive vibration or pulsation of refrigeration lines;
(12) Protect piping, fittings, and protective devices from environmental damage, including water accumulation and freezing in the condensate pipe, or contamination.
(13) Refrigerant piping should be installed to accommodate normal thermal expansion and contraction during operation.
(14) The design and installation of the refrigeration piping system must minimize the risk of hydraulic shock (liquid slugging) within the system.
(15) The solenoid valve should be properly installed in the pipeline to avoid hydraulic shock. Unless sufficient pressure relief is provided, it must not block the liquid refrigerant;
(16) Steel pipes and components shall be protected by rust-resistant coatings to prevent corrosion before contacting any insulating materials;
(17) Electrical components that are not rated as ignition sources under UL 60335-2-40 / UL 60335-2-4 must only be replaced with manufacturer-approved parts. Using non-approved components may create an ignition risk if refrigerant leakage occurs.

NOTICE

- | |
|---|
| (1) Turn the unit off and disconnect power before cleaning.
Shut off the circuit breaker and unplug the unit (if applicable) to avoid the risk of electric shock. |
| (2) Do not wash the air conditioner with water, Spraying water directly on electrical components may cause electric shock or fire. |
| (3) When cleaning the filter, please be careful of your steps. If working at height, take proper safety precautions. |
| (4) Only use manufacturer-approved electrical components when replacements are required.
The manufacturer is not responsible for damage caused by installing non-approved components that may produce sparks or arcing. |

4.3.1 Heat Exchanger of Outdoor Unit

Conduct cleaning for the heat exchanger of outdoor unit periodically, It is recommended to **clean it at least once every two months**. Remove dust and debris from the heat exchanger surface using: a **soft nylon brush**, vacuum or dust collector. If compressed air is available, it may be used to blow dust off the heat exchanger. Don't clean with tap water.

4.3.2 Drainage Pipe

Periodically check the condensate drain pipe to ensure it is **not blocked** and that condensate can drain freely.

4.3.3 Pre-Season Inspection

- (1) Check if the air inlet/outlet of the units are blocked.
- (2) Check if the ground connection is secure.
- (3) Check if the air filter is installed properly.
- (4) If the unit has been off for an extended period, **turn on power at least 8 hours before starting the system** so the compressor crankcase heater can warm the compressor.
- (5) Ensure the outdoor unit is securely mounted. If it is loose please contact your dealer or installing contractor.

4.3.4 Maintenance at the End of the Using Season

- (1) Cut off the main power of air conditioner.
- (2) Clean the dust and debris from the outdoor unit.
- (3) If the outdoor unit is rusty, coat the rusty location with paint to prevent it from expanding.

4.3.5 Components Replacement

Replacement parts are available through your dealer or contractor.

4.4 Maintenance Notice

4.4.1 Service Information

This manual provides important information for qualified service personnel who are servicing equipment that uses flammable refrigerant. Service technicians must follow the procedures below when working on the system.

4.4.1.1 General Work Area

All maintenance staff and others working in the local area shall be instructed on the nature of work being carried out. Working in confined spaces needs to be avoided. The area around the workspace needs to be sectioned off. Ensure the surrounding area is **free of flammable materials** and safe before beginning service work.

4.4.1.2 Checks to the Refrigeration Equipment

When replacing electrical components, ensure the components are **suitable for the application and meet the correct specifications**. Always follow the manufacturer's service and maintenance instructions. If there is any uncertainty, consult the dealer's technical support department..

For systems using flammable refrigerants, the following checks must be performed:

- (1) Verify that ventilation systems and outlets are operating properly and are not blocked.
- (2) If an **indirect refrigeration circuit** is used, inspect the secondary circuit to ensure **no refrigerant is present where it should not be**.
- (3) Ensure all **equipment labels, safety markings, and warning signs remain visible and legible**. Replace or repair any labels that are damaged or unreadable
- (4) Ensure that **refrigerant piping and components are installed in locations where they will not be exposed to substances that may cause corrosion**. If exposure cannot be avoided, the components must be made from **corrosion-resistant materials** or protected with appropriate corrosion protection.

4.4.1.3 Checks of Electrical Devices

Repair and maintenance to electrical components shall include initial safety checks and component inspection procedures. If a fault exists that could compromise safety, then no electrical supply shall be connected to the circuit until it is satisfactorily dealt with. If the fault cannot be corrected immediately but it is necessary to continue operation, an adequate temporary solution shall be used. This shall be reported to the owner of the equipment so all parties are advised.

Initial safety checks shall include:

- (1) Ensure capacitors are fully discharged before working on electrical components to prevent sparking.
- (2) Ensure that **no energized electrical components or exposed wiring are present** while charging, recovering, or purging the refrigeration system.
- (3) Verify **continuity of the equipment grounding**.

4.4.2 Repairs to Sealed Components

4.4.2.1 Electrical Safety

Before removing any sealed covers or enclosures, **disconnect the electrical supply from the equipment** being serviced. If it is absolutely necessary for the equipment to remain energized during servicing, a **continuous refrigerant leak detection device** must be placed at the most critical location to warn of a potentially hazardous condition.

4.4.2.2 Particular Attention

When servicing electrical components, **do not modify or damage the equipment enclosure in a way that reduces its level of protection**. Pay particular attention to the following: Damage to electrical cables, Excessive or improper electrical connections, Terminals not installed according to the original specifications, Damaged seals or gaskets, Incorrect installation of cable glands or strain relief fittings.

- Ensure the following: The equipment is securely mounted, **Seals and sealing materials are intact** and still capable of preventing the entry of flammable gases, or vapors, Replacement parts meet the manufacturer's specifications.

NOTICE

The use of silicon sealant may inhibit the effectiveness of some types of leak detection equipment. Intrinsically safe components do not have to be isolated before servicing.

4.4.3 Repair to Intrinsically Safe Components

Do not add permanent **inductive or capacitive loads** to a circuit unless it is confirmed that doing so will not exceed the **permissible voltage and current ratings** of the equipment. Intrinsically safe components are the only types that can be worked on while the equipment is energized in the presence of a flammable atmosphere. Any test equipment used must have the **appropriate safety rating**.

When replacing components, **use only parts specified by the manufacturer**. Using non-approved parts may create a risk of **refrigerant ignition if a leak occurs**.

4.4.4 Cabling

Check that cabling will not be subject to wear, corrosion, excessive pressure, vibration, sharp edges or any other adverse environmental effects. The inspection should also consider the effects of **aging and continuous vibration**, particularly from nearby equipment such as **compressors or fans**.

4.4.5 Charging Procedures

In addition to conventional charging procedures, the following requirements must be followed.

- (1) Ensure that contamination of different refrigerants does not occur when using charging equipment. Hoses or lines shall be as short as possible to minimize the amount of refrigerant contained in them.
- (2) Cylinders shall be kept upright.
- (3) Ensure that the refrigeration system is properly grounded prior to charging the system with refrigerant.
- (4) Label the system after charging is complete (if not already).
- (5) Take extreme care not to overfill the refrigeration system.
- (6) Before charging, the system must be **pressure tested using dry Nitrogen**.

After charging, perform a **leak test before commissioning** the system.

A final leak check should be completed **before leaving the installation**.

4.4.6 Decommissioning

Before carrying out this procedure, the technician needs to be completely familiar with the equipment and all its details. It is recommended good

practice that all refrigerants are recovered safely. Before beginning the work, it is recommended that **oil and refrigerant samples be taken** in case analysis is required before reclaimed refrigerant is reused. Ensure that **electrical power is available when required to operate recovery equipment**, but the system itself must be isolated before service begins. Become familiar with the equipment and its operation.

- (1) Isolate system electrically.
- (2) Before attempting the procedure ensure that:
 - 1) Mechanical handling equipment is available, if required, for handling refrigerant cylinders.
 - 2) All personal protective equipment is available and being used correctly.
 - 3) The recovery process is supervised at all times by a qualified technician.
 - 4) Recovery equipment and cylinders conform to the appropriate standards.
- (3) Pump down refrigerant system, if possible.
- (4) If pump-down is not possible, connect a **manifold gauge set** so refrigerant can be recovered from different parts of the system.
- (5) Ensure the recovery cylinder is placed on a scale before starting the refrigerant recovery.
- (6) Start the recovery machine and operate in accordance with manufacturer's instructions.
- (7) Do not overfill cylinders. The cylinder must not exceed **80% of its liquid capacity**.
- (8) Do not exceed the maximum working pressure of the cylinder, even temporarily.
- (9) When the cylinders have been filled correctly and the process completed, make sure that the cylinders and the equipment are removed from site promptly and all isolation valves on the equipment are closed.
- (10) Recovered refrigerant shall not be charged into another refrigeration system unless it has been cleaned and checked.

4.4.7 Labelling

Equipment shall be labelled stating that it has been decommissioned and emptied of refrigerant. The label needs to be dated and signed.

4.4.8 Recovery

When removing refrigerant from a system, either for servicing or decommissioning, it is recommended good practice that all refrigerants are removed safely.

When transferring refrigerant into cylinders, ensure that only appropriate refrigerant recovery cylinders are used. Ensure that the correct number of cylinders for holding the total system charge are available. All cylinders to be used are designated for the recovered refrigerant and labelled for that refrigerant (i.e. special cylinders for the recovery of refrigerant).

Cylinders shall be complete with pressure relief valve and associated shut-off valves in good working order.

In addition, a set of calibrated weighing scales should be available and in good working order. Hoses shall be complete with leak-free disconnect couplings and in good condition. Before using the recovery machine, check that it is in satisfactory working order, has been properly maintained Consult the manufacturer if in doubt.

The recovered refrigerant shall be returned to the refrigerant supplier in the correct recovery cylinder, and the relevant Waste Transfer Notice arranged. Do not mix refrigerants in recovery units and especially not in cylinders.

If compressors or compressor oil must be removed, ensure the system has been **evacuated to an appropriate vacuum level** so that **no flammable refrigerant remains dissolved in the oil**. The evacuation procedure must be completed **before returning the compressor to the supplier or manufacturer**.

If any **quality or performance issues** are encountered with the air conditioner, please contact the **dealer**.

5 Qualification of Worker

The manual must include information regarding the **required qualifications of personnel performing maintenance, service, and repair work**. Any procedures that affect the safety of the equipment must be carried out **only by properly trained and qualified technicians**. Training for these procedures should be provided by **recognized training organizations or the equipment manufacturer**, in accordance with applicable national standards and regulations. The achieved competence should be documented by a certificate demonstrating their competency.

Examples for such working procedures are:

- (1) Breaking into the refrigerating circuit;
- (2) Opening of sealed components;
- (3) Opening of ventilated enclosures.

6 Transportation, Marking and Storage for Units that Employ Flammable Refrigerants

6.1 General

The following information is provided for units that employ FLAMMABLE REFRIGERANTS.

6.2 Transport of Equipment Containing Flammable Refrigerants

Additional transportation regulations may exist for equipment containing flammable gas. The maximum number of pieces of equipment or the configuration of the equipment permitted to be transported together will be determined by the applicable transport regulations.

6.3 Marking of Equipment Using Signs

Safety signage for similar equipment used in a work area should comply with applicable local regulations, which establish the minimum requirements for workplace safety and health signage.

All required signs must be maintained in good condition, and employers should ensure that employees receive appropriate training on the meaning of these signs and the actions required when they are encountered.

Sign effectiveness should not be reduced by placing too many signs together, and any pictograms used should be simple and include only essential information.

6.4 Disposal of Equipment Using Flammable Refrigerants

See national regulations.

6.5 Storage of Equipment / Appliances

The storage of the appliance should be in accordance with the applicable regulations or instructions, whichever is more stringent.

6.6 Storage of Packed (Unsold) Equipment

Storage package protection should be constructed in such a way that mechanical damage to the equipment inside the package will not cause a leak of the REFRIGERANT CHARGE.

The maximum number of pieces of equipment permitted to be stored together will be determined by local regulations.

7 Information on Servicing

7.1 General

The manual contains specific information for service personnel see 7.2 to 7.10.

7.2 Checks to the Area

Prior to beginning work on systems containing FLAMMABLE REFRIGERANTS, safety checks are necessary to ensure that the risk of ignition is minimized. For repair to the **refrigerant system**, 7.3 to 7.7 must be completed prior to conducting work on the system.

7.3 Work Procedure

Work shall be undertaken under a controlled procedure to minimize the risk of flammable gas or vapor being present while the work is being performed.

7.4 General Work Area

All maintenance staff and others working in the local area must be instructed on the nature of work being carried out. Work in confined spaces must be avoided.

7.5 Checking for Presence of Refrigerant

The area must be checked with an appropriate refrigerant detector prior to and during work, to ensure the technician is aware of potentially toxic or flammable atmospheres. Ensure that the leak detection equipment being used is suitable for use with all applicable refrigerants, i.e. non-sparking, adequately sealed or intrinsically safe.

7.6 Presence of Fire Extinguisher

If any hot work is to be conducted on the refrigerating equipment or any associated parts, appropriate fire extinguishing equipment shall be available to hand. Have a dry powder or CO₂ fire extinguisher adjacent to the charging area.

7.7 No Ignition Sources

No person performing work on a **refrigeration system that involves opening refrigerant piping** shall use any ignition sources in a way that could create a fire or explosion hazard. All potential ignition sources, including smoking, must be kept well away from the installation, service, removal, or disposal area where refrigerant may be released. Before beginning work, the area around the equipment should be inspected to ensure there are **no flammable hazards or ignition sources present**. **“No Smoking” signs must be posted.**

7.8 Ventilated Area

Ensure that the area is in the open or that it is adequately ventilated before breaking into the system or conducting any hot work. A degree of ventilation shall continue during the period that the work is carried out. The ventilation should safely disperse any released refrigerant and preferably expel it externally into the atmosphere.

7.9 Checks to the Refrigerating Equipment

Where electrical components are being **replaced**, they must be suitable for the intended purpose and meet the correct specifications. The manufacturer's maintenance and service guidelines must always be followed. If there is any uncertainty, consult the manufacturer's technical department for assistance. The following checks apply to installations using **flammable refrigerants**:

- (1) Verify that the **actual refrigerant charge complies with the allowable limits for the room size** where the refrigerant-containing components are installed.

7.10 Checks of Electrical Devices

Repair and maintenance of electrical components must include **initial safety checks and component inspections**. If a fault exists that could compromise safety, electrical power must **not be applied to the circuit** until the issue has been properly corrected. If the fault cannot be corrected immediately but operation must continue, an **appropriate temporary solution** must be implemented. The equipment owner should be informed so that all parties are aware.

Initial safety checks must include:

- (1) **Capacitors are properly discharged** using safe procedures to prevent sparking.
- (2) No energized electrical components or wiring are exposed while charging, recovering, or purging the system.
- (3) **Continuity of the equipment grounding** is verified.

WARNING

Only accessories approved by the manufacturer or rated for use with the refrigerant may be installed in duct systems connected to the appliance. For ducted systems, **drop ceiling or suspended ceiling may be used as a return air plenum only if the unit includes a refrigerant detection system**, and any external connections include a sensor installed directly below the return air plenum duct joint.

7.11 Pipe Installation

Refrigerant piping, including piping materials, routing, and installation, must be protected from **physical damage during operation and service** and must comply with applicable **national and local codes and standards**, such as ASHRAE 15, ASHRAE 15.2, the IAPMO Uniform Mechanical Code, the ICC International Mechanical Code, or CSA B52. All field joints must remain **accessible for inspection before being covered or enclosed**;

After completing field piping for split systems, the piping must be **pressure tested with an inert gas** and then **evacuated prior to refrigerant charging**. Field-made refrigerant joints located indoors must be leak tested using a method capable of detecting **5 grams per year of refrigerant leakage or better**, at a pressure of at least **0.25 times the maximum allowable pressure**. No leaks are permitted.

The **minimum test pressure for the low side** of the system must be the **low-side design pressure**, and the **minimum test pressure for the high side** must be the **high-side design pressure**. If the high side cannot be isolated from the low side, the **entire system must be pressure tested to the low-side design pressure**.

8 Sealed Electrical Components

Must be replaced only in accordance with the manufacturer's instructions.

9 Intrinsically Safe Components

Must be replaced only with parts specified by the manufacturer.

10 Cables

Inspect cables to ensure it is not subject to wear, corrosion, excessive pressure, vibration, sharp edges, or other environmental damage. Consider the effects of aging and continuous vibration from sources such as compressors or fans.

11 Detection of Flammable Refrigerants

Ignition sources must never be used when searching for or detecting refrigerant leaks. Halide torches or any leak detection devices that use an open flame must not be used.

The following leak detection methods are deemed acceptable for refrigerant systems.

Electronic leak detectors may be used, but for **flammable refrigerants** they must be properly calibrated and suitable for the refrigerant being used. Detectors must not act as a potential ignition source and should be set to detect concentrations at a percentage of the refrigerant's **Lower Flammability Limit (LFL)**, with confirmation at **no more than 25% of the LFL**.

Leak detection fluids may also be used with most refrigerants; however, **detergents containing chlorine must not be used**, as chlorine can react with refrigerant and corrode copper piping.

NOTE Examples of leak detection fluids are

- (1) Bubble method.
- (2) Fluorescent leak detection dyes.

If a leak is suspected, all open flames must be removed/extinguished.

If a refrigerant leak is found that requires brazing, **all refrigerant must be recovered from the system**, or isolated using shutoff valves in a section of the system away from the leak. Refrigerant recovery must be performed in accordance with **Clause 12**.

12 Removal and Evacuation

When opening the refrigerant circuit to perform repairs or service, standard service procedures must be followed. However, when working with flammable refrigerants, additional precautions are required.

The refrigerant charge must be **recovered into approved recovery cylinders** unless venting is permitted by local or national regulations. For systems containing flammable refrigerants, the system must then be **purged with dry Nitrogen** to make the equipment safe for service. This purging process may need to be **repeated several times**.

- Safely recover refrigerant in accordance with local and national regulations;
- Evacuate the system;
- Purge the circuit with an inert gas (optional for A2L refrigerants);
- Evacuate again (optional for A2L refrigerants);
- When using a flame to open the refrigerant circuit, continuously purge the system with inert gas;
- Open the refrigerant circuit.

Compressed air or oxygen **must not** be used for purging refrigerant systems. For systems containing flammable refrigerants, purging must be performed by breaking the vacuum with dry Nitrogen and continuing to pressurize until the working pressure is reached, then venting to atmosphere and evacuating again (optional for A2L refrigerants). This process should be repeated until no refrigerant remains in the system. After the final oxygen OFN charge, vent the system to atmospheric pressure before performing any work.

The outlet of the vacuum pump must **not be located near any potential ignition sources**, and adequate ventilation must be provided.

13 Charging Procedures

In addition to conventional charging procedures, the following requirements must be followed.

- (1) Ensure that **cross-contamination of different refrigerants does not occur** when using charging equipment.
- (2) Keep hoses or charging lines **as short as possible** to minimize the amount of refrigerant contained in them.
- (3) Keep refrigerant cylinders **in the proper position according to the manufacturer's instructions**.
- (4) Ensure the **refrigeration system is properly grounded** before charging with refrigerant.
- (5) **Label the system after charging** if it has not already been labeled.
- (6) Take care **not to overfill the refrigeration system**.

Before recharging, the system must be **pressure tested using the appropriate purge gas**. After charging, the system must be **leak tested before commissioning**, and a **final leak check must be performed before leaving the site**.

14 Decommissioning

Before performing this procedure, the technician must be fully familiar with the equipment and its operation. All refrigerant should be recovered safely in accordance with proper recovery procedures.

Before beginning the work, an **oil and refrigerant sample should be taken** if analysis may be required before reusing recovered refrigerant. Electrical power must be **available for recovery equipment**, but the system itself must be **isolated electrically before service begins**.

(1) Become familiar with the equipment and its operation, then **isolate the system electrically**.

(2) Before beginning the procedure, ensure that:

1. **Mechanical handling equipment** is available if required for handling refrigerant cylinders.
2. **All required personal protective equipment (PPE)** is available and used properly.
3. The **recovery process is supervised by a qualified person**.
4. **Recovery equipment and cylinders comply with applicable standards**.

- (1) **Pump down the refrigerant system**, if possible.
- (2) If pump-down is not possible, **connect a manifold gauge set** so refrigerant can be recovered from different parts of the system.
- (3) Ensure the **recovery cylinder is placed on a scale** before recovery begins.
- (4) **Start the recovery machine** and operate it according to the manufacturer's instructions.
- (5) **Do not overfill recovery cylinders** (maximum **80% liquid volume**).
- (6) Do not exceed the **maximum working pressure of the cylinder**, even temporarily.
- (7) Once recovery is complete and cylinders are properly filled, **remove the cylinders and recovery equipment from the site promptly** and ensure all isolation valves on the equipment are **closed**.
- (8) **Recovered refrigerant must not be charged into another refrigeration system** unless it has been properly **cleaned and verified for reuse**.

15 Labelling

The equipment must be **labelled to indicate that it has been decommissioned and the refrigerant has been removed**. The label must be **dated and signed**.

For systems containing **flammable refrigerants**, ensure the equipment is clearly labelled indicating that it **contains (or previously contained) flammable refrigerant**.

15 Recovery

When removing refrigerant from a system for servicing or decommissioning, all refrigerant should be recovered safely using proper procedures.

When transferring refrigerant into cylinders, use **approved refrigerant recovery cylinders only**. Ensure enough cylinders are available to contain the entire system charge. Cylinders must be **designated and labeled for the specific refrigerant being recovered**. Recovery cylinders must be equipped with **pressure relief valves and functional shutoff valves**. Empty cylinders should be **evacuated and, if possible, cooled before recovery begins**.

Recovery equipment must be **in good working condition**, suitable for the refrigerant being recovered, and used according to the manufacturer's instructions. **Calibrated weighing scales** must be available and functioning properly. Hoses must be in good condition and equipped with **leak-free quick-disconnect fittings**.

Recovered refrigerant must be **handled in accordance with applicable local regulations** and stored in the proper recovery cylinders. **Do not mix different refrigerants** in recovery equipment or cylinders. If compressors or compressor oil are removed, ensure the system has been **evacuated sufficiently so that no flammable refrigerant remains in the oil**. Do not heat the compressor with an open flame or other ignition source to accelerate this process. When draining oil from the system, it must be done **safely and in accordance with proper procedures**.



66139913062