

BPRPHP14

PRODUCT SPECIFICATIONS

14 SEER HEAT PUMP PACKAGED UNIT

FORM NO. BPRPHP14-100 (11/2022)

REFRIGERANT SYSTEM

- Environmentally friendly R410A refrigerant
- Copper tubing with enhanced fin coils
- Internal service gauge ports
- Sleeved distributor tubes
- Antimicrobial insulated drain pan
- High and Low Threaded pressure switches for system protection

CABINET CONSTRUCTION

- Heavy-gauge galvanized steel base rails with rigging holes
- Rounded corners for safety and an attractive, clean appearance
- One piece base design for strength and stability
- Condensate and coil runoff drains to the perimeter of the unit
- Horizontal and downflow duct openings are flanged to minimize water entry
- Low profile, with compact footprint
- Insulation to minimize heat loss plus reduce sound
- Textured pre-painted steel cabinet finish
- Superior service access to components
- Louvered coil guard protection
- One piece “no leak” top design

BLOWER

- Insulated compartment to reduce sound
- Efficient constant torque motor for wide airflow range
- Slide out blower housing for easy service

CONTROLS

- Integrated control with L.E.D. self diagnostics
- Defrost control board with field selectable time intervals
- Built in short cycle protection to protect compressor
- Built in “quiet shift” operation during defrost on select models

INSTALLATION

- Horizontal or down discharge capable
- Horizontal and downflow duct covers provided with unit for installation flexibility
- Drain pan float switch monitors condensate level in drain pan and shuts down unit if drain becomes clogged
- Utility connections on “right side”
- Kits enable bottom gas and power entry through base pan
- Seismic Certification (with Seismic Strapping Kit applied): Latest Edition of International Building Code, California Building Code, and ASCE 7-16



ACCESSORIES

- Clip roof curbs and adjustable pitch roof curbs available
- Internal filter kits
- Electric strip heat with optional single point power entry (side entry only)
- Duct adapters
- Closure kit for base rail openings

WARRANTY

10 year limited parts and compressor warranty. See limited warranty document for details.



MODEL NUMBER GUIDE

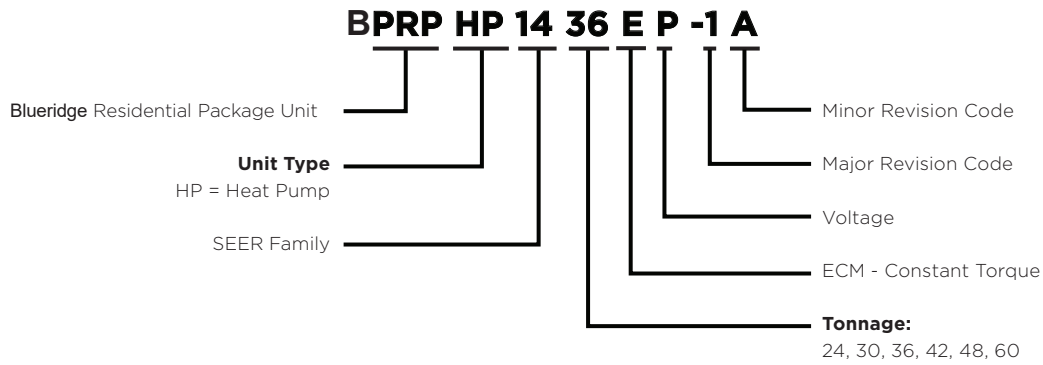

ELECTRICAL AND PHYSICAL DATA

Model	Voltage	Phase	Hz	Min Volts @ 60 hz	MCA	Max Fuse/ HACR Breaker	Compressor		Condenser Motor		Blower Motor		Refrig. Charge (oz.)	Weight (lbs.)
							RLA	LRA	RLA	HP	RLA	HP		
BPRPHP1424	208-230	1	60	197	17.4	25	10.9	59.3	1.0	1/6	2.8	1/3	86	369
BPRPHP1430					22.7	35	14.1	67.9			4.1	1/2	91	379
BPRPHP1436					26.0	35	14.7	75.0	1.7	1/4	4.1	1/2	91	388
BPRPHP1442					28.0	40	16.2	113.0			6.0	3/4	167	460
BPRPHP1448					35.1	50	21.9	110.0	6.0	3/4	173	464		
BPRPHP1460					43.6	60	27.0	150.0	3.6	1/2	6.3	1.0	174	522

PERFORMANCE

MODEL	COOLING				HEATING					Sound dBA
	Rated AHRI Capacity Btuh (SEER / SEER2)	Efficiency		Rated Sensible Capacity Btuh (SEER / SEER2)	47 DEG.		HSPF / HSPF2	17 DEG.		
		SEER / EER	SEER2 / EER2		BTUH (HSPF / HSPF2)	COP (HSPF / HSPF2)		BTUH (HSPF / HSPF2)	COP (HSPF / HSPF2)	
BPRPHP1424	22,600 / 23,000	14.0 / 11.0	13.4 / 10.6	17,800 / 18,100	22,000 / 21,600	3.8 / 3.4	8.0 / 6.7	12,300 / 11,900	2.3 / 1.9	78
BPRPHP1430	28,600 / 28,600			22,500 / 22,500	27,000 / 25,800	3.7 / 3.7		15,900 / 15,000	2.3 / 2.2	78
BPRPHP1436	34,000 / 34,000			26,800 / 26,800	32,400 / 32,600	3.7 / 3.6		20,000 / 18,300	2.3 / 2.1	78
BPRPHP1442	40,000 / 39,500			31,200 / 30,800	39,000 / 40,000	3.6 / 3.5		23,600 / 22,500	2.3 / 2.1	78
BPRPHP1448	46,000 / 45,500			35,800 / 35,400	45,000 / 47,000	3.7 / 3.6		27,000 / 28,200	2.3 / 2.3	79
BPRPHP1460	57,000 / 56,000			43,300 / 42,500	56,000 / 58,000	3.7 / 3.3		33,600 / 33,300	2.4 / 2.0	78

*Certified in accordance with Unitary Air Conditioner Certification Program, which is based on AHRI Standard 210/240

BLOWER PERFORMANCE

Model	Blower Tap	CFM @ ext. Static Pressure in in. wc without filter, dry coil									
		0.1	0.2	0.3	0.4	0.5	0.6	0.7	0.8	0.9	1.0
BPRPHP1424	TAP 1	680	590	550	450	380	N/A	N/A	N/A	N/A	N/A
	TAP 2	890	830	800	760	710	680	640	600	N/A	N/A
	TAP 3	1000	965	930	900	870	835	805	770	740	695
BPRPHP1430	TAP 1	680	640	600	570	530	490	N/A	N/A	N/A	N/A
	TAP 2	1100	1070	1050	1020	990	960	930	900	N/A	N/A
	TAP 3	1195	1160	1130	1110	1070	1040	1005	970	935	875
BPRPHP1436	TAP 1	860	810	760	710	640	590	550	490	N/A	N/A
	TAP 2	1300	1265	1235	1200	1165	1125	1085	1040	1000	885
	TAP 3	1450	1425	1395	1350	1320	1285	1250	1165	1045	860
BPRPHP1442	TAP 1	800	720	640	550	475	390	310	0	0	0
	TAP 2	1470	1410	1360	1300	1260	1210	1155	1095	1000	940
	TAP 3	1580	1540	1505	1460	1415	1370	1320	1235	1135	1060
BPRPHP1448	TAP 1	1145	1075	1000	930	850	790	740	670	570	490
	TAP 2	1675	1630	1600	1540	1490	1440	1390	1300	1230	1125
	TAP 3	1840	1800	1760	1720	1670	1615	1555	1500	N/A	N/A
BPRPHP1460	TAP 1	1400	1320	1260	1200	1120	1060	980	900	N/A	N/A
	TAP 2	1920	1870	1820	1770	1720	1670	1450	1360	N/A	N/A
	TAP 3	1970	1915	1865	1820	1770	1725	1685	1640	1595	1540

COOLING PERFORMANCE - EXTENDED RATINGS

Outdoor Model	Indoor Temp DB/WB °F	Outdoor Temperature - DB °F														
		65°			82° / 67°			95° / 75°			105° / 85°			115° / 95°		
		Btuh	S/T	kW	Btuh	S/T	kW	Btuh	S/T	kW	Btuh	S/T	kW	Btuh	S/T	kW
BPRPHP1424	85 / 72	28600	0.67	1.35	26700	0.69	1.62	25300	0.73	1.87	23900	0.75	2.09	22400	0.78	2.35
	80 / 67	26400	0.73	1.36	24700	0.76	1.63	22600	0.79	1.87	22000	0.82	2.10	20600	0.85	2.36
	75 / 63	24600	0.76	1.36	23000	0.78	1.63	21700	0.82	1.88	20500	0.84	2.10	19100	0.87	2.36
	75 / 57	23000	1.00	1.37	21600	1.00	1.64	20600	1.00	1.88	19600	1.00	2.11	18500	1.00	2.37
BPRPHP1430	85 / 72	35700	0.68	1.79	33400	0.70	2.10	31400	0.73	2.39	29600	0.75	2.65	27700	0.78	2.96
	80 / 67	32900	0.74	1.78	30800	0.76	2.10	28600	0.80	2.38	27200	0.82	2.64	25400	0.85	2.95
	75 / 63	30800	0.76	1.78	28700	0.79	2.09	26900	0.82	2.38	25400	0.84	2.64	23700	0.87	2.95
	75 / 57	28600	1.00	1.77	26900	1.00	2.09	25400	1.00	2.37	24200	1.00	2.64	22800	1.00	2.94
BPRPHP1436	85 / 72	44200	0.67	2.21	40700	0.70	2.62	37900	0.72	2.97	35600	0.74	3.29	33000	0.77	3.66
	80 / 67	40600	0.73	2.16	37300	0.76	2.58	34000	0.79	2.92	32500	0.82	3.24	30100	0.85	3.61
	75 / 63	37700	0.76	2.13	34700	0.78	2.55	32200	0.81	2.89	30200	0.84	3.21	27900	0.87	3.58
	75 / 57	34700	1.00	2.11	32300	1.00	2.52	30400	1.00	2.87	28700	1.00	3.19	26900	1.00	3.57
BPRPHP1442	85 / 72	48800	0.67	2.25	46600	0.69	2.89	43800	0.72	3.27	41100	0.74	3.59	38200	0.77	3.94
	80 / 67	44600	0.73	2.25	42800	0.75	2.90	40000	0.79	3.29	37700	0.81	3.62	35000	0.84	3.99
	75 / 63	41400	0.76	2.25	39800	0.77	2.90	37400	0.81	3.30	35100	0.83	3.63	32600	0.87	4.01
	75 / 57	38300	1.00	2.24	37100	1.00	2.90	35100	1.00	3.30	33300	1.00	3.63	31300	1.00	4.02
BPRPHP1448	85 / 72	56500	0.67	2.81	52800	0.69	3.31	50000	0.72	3.79	47200	0.74	4.22	44100	0.77	4.68
	80 / 67	52100	0.73	2.82	48600	0.75	3.30	46000	0.79	3.78	43500	0.81	4.19	40500	0.84	4.67
	75 / 63	48600	0.75	2.82	45400	0.78	3.30	42900	0.81	3.76	40500	0.83	4.19	37800	0.86	4.66
	75 / 57	45100	1.00	2.82	42400	1.00	3.30	40400	1.00	3.76	38500	1.00	4.18	36300	1.00	4.66
BPRPHP1460	85 / 72	69200	0.65	3.49	64500	0.68	4.10	60400	0.70	4.67	57100	0.71	5.20	53300	0.74	5.79
	80 / 67	63900	0.71	3.48	59600	0.74	4.08	57000	0.76	4.66	52600	0.78	5.17	49100	0.81	5.76
	75 / 63	59800	0.74	3.47	55600	0.76	4.06	52100	0.78	4.63	49200	0.80	5.15	45800	0.83	5.74
	75 / 57	54800	0.99	3.46	51400	1.00	4.05	48600	1.00	4.61	46100	1.00	5.13	43500	1.00	5.72

NOTE: Values based on 0.50" w.c. external static pressure

COOLING PERFORMANCE - EXTENDED RATINGS

Outdoor Model	Indoor Temp DB/WB °F	Outdoor Temperature - DB °F														
		65°			82° / 67°			95° / 75°			105° / 85°			115° / 95°		
		Btuh	S/T	kW	Btuh	S/T	kW	Btuh	S/T	kW	Btuh	S/T	kW	Btuh	S/T	kW
BPRPHP1424	85 / 72	28400	0.67	1.42	26500	0.69	1.69	25100	0.72	1.94	23700	0.75	2.16	22200	0.77	2.42
	80 / 67	26200	0.73	1.43	24400	0.75	1.70	23000	0.79	1.94	21800	0.82	2.17	20400	0.85	2.43
	75 / 63	24400	0.75	1.43	22800	0.78	1.70	21500	0.82	1.95	20300	0.84	2.17	18900	0.87	2.43
	75 / 57	22700	1.00	1.44	21400	1.00	1.71	20400	1.00	1.95	19400	1.00	2.17	18300	1.00	2.44
BPRPHP1430	85 / 72	35500	0.68	1.86	33100	0.70	2.17	31100	0.73	2.46	29400	0.75	2.72	27400	0.78	3.03
	80 / 67	32700	0.74	1.85	30500	0.76	2.17	28600	0.79	2.45	27000	0.82	2.71	25200	0.85	3.02
	75 / 63	30600	0.76	1.84	28500	0.79	2.16	26700	0.82	2.45	25100	0.84	2.71	23400	0.87	3.01
	75 / 57	28400	1.00	1.84	26700	1.00	2.16	25200	1.00	2.44	24000	1.00	2.70	22600	1.00	3.01
BPRPHP1436	85 / 72	43800	0.67	2.32	40400	0.69	2.73	37600	0.72	3.08	35200	0.74	3.39	32600	0.77	3.77
	80 / 67	40200	0.73	2.27	36900	0.76	2.69	34000	0.79	3.03	32200	0.81	3.35	29800	0.85	3.72
	75 / 63	37300	0.75	2.24	34300	0.78	2.66	31900	0.81	3.00	29800	0.84	3.32	27600	0.87	3.69
	75 / 57	34300	1.00	2.22	31900	1.00	2.63	30000	1.00	2.98	28400	1.00	3.30	26600	1.00	3.68
BPRPHP1442	85 / 72	48500	0.67	2.35	46300	0.69	2.99	43500	0.72	3.37	40800	0.74	3.68	37900	0.77	4.04
	80 / 67	44300	0.73	2.34	42500	0.75	3.00	39500	0.78	3.39	37400	0.81	3.71	34700	0.84	4.08
	75 / 63	41100	0.76	2.34	39500	0.77	3.00	37100	0.81	3.40	34800	0.83	3.73	32300	0.86	4.10
	75 / 57	38000	1.00	2.34	36800	1.00	3.00	34800	1.00	3.40	33000	1.00	3.73	31000	1.00	4.11
BPRPHP1448	85 / 72	56200	0.67	2.90	52500	0.69	3.40	49700	0.72	3.88	46900	0.74	4.31	43800	0.77	4.77
	80 / 67	51800	0.73	2.91	48300	0.75	3.40	45500	0.78	3.87	43200	0.81	4.28	40200	0.84	4.76
	75 / 63	48300	0.75	2.91	45100	0.77	3.39	42600	0.81	3.85	40200	0.83	4.28	37500	0.86	4.75
	75 / 57	44800	1.00	2.91	42100	1.00	3.39	40100	1.00	3.85	38200	1.00	4.27	36000	1.00	4.75
BPRPHP1460	85 / 72	69100	0.65	3.52	64400	0.68	4.13	60300	0.70	4.71	57000	0.71	5.23	53200	0.74	5.82
	80 / 67	63800	0.71	3.51	59400	0.74	4.11	56000	0.76	4.69	52500	0.78	5.20	49000	0.81	5.80
	75 / 63	59700	0.74	3.51	55500	0.76	4.09	52000	0.78	4.67	49000	0.80	5.18	45700	0.83	5.77
	75 / 57	54700	0.99	3.49	51300	1.00	4.08	48500	1.00	4.65	46000	1.00	5.16	43400	1.00	5.76

NOTE: Values based on 0.58" w.c. external static pressure

ACCESSORY AIR RESISTANCE DATA - in. w.g.

Air Volume cfm	Rectangular to Round Duct Adaptor Kits					
	Downflow			Horizontal		
	14 in. Diameter		14 in. Diameter		16 in. Diameter	18 in. Diameter
	24, 30, 36	42, 48, 60	24, 30, 36	42, 48, 60	42, 48, 60	42, 48, 60
500	0.03	---	0.04	---	---	---
600	0.05	---	0.07	---	---	---
700	0.08	0.13	0.08	0.13	---	---
800	0.10	0.17	0.12	0.16	---	---
900	0.12	0.21	0.15	0.21	---	---
1000	0.17	0.24	0.19	0.25	0.11	0.03
1100	0.18	0.30	0.23	0.30	0.11	0.03
1200	0.20	0.36	0.29	0.37	0.13	0.03
1300	0.26	0.43	0.31	0.43	0.17	0.03
1400	0.31	0.50	0.39	0.51	0.20	0.03
1500	---	0.57	---	0.57	0.21	0.05
1600	---	0.63	---	0.65	0.26	0.05
1700	---	0.71	---	0.72	0.30	0.06
1800	---	0.80	---	0.81	0.30	0.06
1900	---	0.91	---	0.90	0.40	0.06
2000	---	0.99	---	1.01	0.41	0.06

HEAT STRIP ELECTRICAL

Model	Heater	Unit Supply Voltage Single Phase	Input kW 240V	Circuit 1 240V		Circuit 2 240V		Single Circuit 240V	
				Ampacity	Breaker	Ampacity	Breaker	Ampacity	Breaker
BPRPHP1424EP	5kW	240	5	29.5	30	-	-	43.5	45
		208	3.8	26.1	30	-	-	40.0	45
	7.5kW	240	7.5	42.6	45	-	-	56.5	60
		208	5.6	37.4	40	-	-	51.3	60
	10kW	240	10	55.6	60	-	-	69.5	70
		208	7.5	48.6	50	-	-	62.6	70
	15kW	240	15	-	-	-	-	-	-
		208	11.3	-	-	-	-	-	-
20kW	240	20	-	-	-	-	-	-	
	208	15	-	-	-	-	-	-	
BPRPHP1430EP	5kW	240	5	31.2	35	-	-	48.7	50
		208	3.8	27.7	30	-	-	45.3	50
	7.5kW	240	7.5	44.2	45	-	-	61.8	70
		208	5.6	39.0	40	-	-	56.9	60
	10kW	240	10	57.2	60	-	-	74.8	80
		208	7.5	50.3	60	-	-	67.8	70
	15kW	240	15	-	-	-	-	-	-
		208	11.3	-	-	-	-	-	-
20kW	240	20	-	-	-	-	-	-	
	208	15	-	-	-	-	-	-	
BPRPHP1436EP	5kW	240	5	31.2	35	-	-	52.1	60
		208	3.8	27.7	30	-	-	48.6	50
	7.5kW	240	7.5	44.2	45	-	-	65.1	70
		208	5.6	39.0	40	-	-	59.9	60
	10kW	240	10	57.2	60	-	-	78.1	80
		208	7.5	50.3	60	-	-	71.2	80
	15kW	240	15	57.2	60	26.0	30	104.1	110
		208	11.3	50.3	60	22.6	25	93.7	100
20kW	240	20	-	-	-	-	-	-	
	208	15	-	-	-	-	-	-	
BPRPHP1442EP	5kW	240	5	33.5	35	-	-	54.0	60
		208	3.8	30.1	35	-	-	50.6	60
	7.5kW	240	7.5	46.6	50	-	-	67.1	70
		208	5.6	41.4	45	-	-	61.9	70
	10kW	240	10	59.6	60	-	-	80.1	90
		208	7.5	52.6	60	-	-	73.1	80
	15kW	240	15	59.6	60	26.0	30	106.1	110
		208	11.3	52.6	60	22.6	25	95.7	100
20kW	240	20	59.6	60	52.1	60	132.2	150	
	208	15	52.6	60	45.1	50	118.3	125	

HEAT STRIP ELECTRICAL

Model	Heater	Unit Supply Voltage Single Phase	Input kW 240V	Circuit 1 240V		Circuit 2 240V		Single Circuit 240V	
				Ampacity	Breaker	Ampacity	Breaker	Ampacity	Breaker
BPRPHP1448EP	5kW	240	5	33.5	35	-	-	61.2	70
		208	3.8	30.1	35	-	-	57.7	70
	7.5kW	240	7.5	46.6	50	-	-	74.2	80
		208	5.6	41.4	45	-	-	69.0	80
	10kW	240	10	59.6	60	-	-	87.2	90
		208	7.5	52.6	60	-	-	80.3	90
	15kW	240	15	59.6	60	26.0	30	113.3	125
		208	11.3	52.6	60	22.6	25	102.8	110
20kW	240	20	59.6	60	52.1	60	139.3	150	
	208	15	52.6	60	45.1	50	125.4	150	
BPRPHP1460EP	5kW	240	5	33.9	35	-	-	69.7	90
		208	3.8	30.4	35	-	-	66.2	80
	7.5kW	240	7.5	46.9	50	-	-	82.7	100
		208	5.6	41.7	45	-	-	77.5	90
	10kW	240	10	60.0	60	-	-	95.7	110
		208	7.5	53.0	60	-	-	88.8	100
	15kW	240	15	60.0	60	26.0	30	121.8	125
		208	11.3	53.0	60	22.6	25	111.3	125
20kW	240	20	60.0	60	52.1	60	147.8	150	
	208	15	53.0	60	45.1	50	133.9	150	

HEATING PERFORMANCE EXT. RATINGS

Model	Outdoor Temp. DB/WB deg. F									
	0/0		17/15		35/33		47/43		62/56	
	Btuh	KW	Btuh	KW	Btuh	KW	Btuh	KW	Btuh	KW
BPRPHP1424	8800	1.69	12300	1.73	17500	1.79	22000	1.83	26100	1.88
BPRPHP1430	11000	1.62	15900	1.68	20900	1.82	27000	1.91	31000	2.02
BPRPHP1436	13000	2.29	20000	2.42	26600	2.72	32400	2.93	39500	3.18
BPRPHP1442	17500	3.27	23600	3.00	33100	3.17	39000	3.28	49500	3.41
BPRPHP1448	20700	3.40	27000	3.46	39500	3.66	45000	3.79	56800	3.96
BPRPHP1460	23700	4.56	33600	4.62	47300	4.64	56000	4.66	71500	4.68

NOTE: Values based on 0.50" w.c. external static pressure

HEATING PERFORMANCE EXT. RATINGS

Model	Outdoor Temp. DB/WB deg. F									
	0/0		17/15		35/33		47/43		62/56	
	Btuh	KW	Btuh	KW	Btuh	KW	Btuh	KW	Btuh	KW
BPRPHP1424	8800	1.76	11900	1.81	17800	1.86	21600	1.90	26700	1.95
BPRPHP1430	11000	1.92	15000	1.98	21600	2.04	25800	2.08	31500	2.12
BPRPHP1436	13000	2.40	18300	2.53	27100	2.64	32600	2.72	40100	2.81
BPRPHP1442	17500	3.38	22500	3.11	33300	3.27	40000	3.38	49500	3.51
BPRPHP1448	20700	3.50	28200	3.57	39700	3.77	47000	3.91	57000	4.07
BPRPHP1460	23700	4.58	33300	4.62	48200	4.95	58000	5.18	72800	5.46

NOTE: Values based on 0.58" w.c. external static pressure

DIMENSIONS (IN.) - SMALL BASE

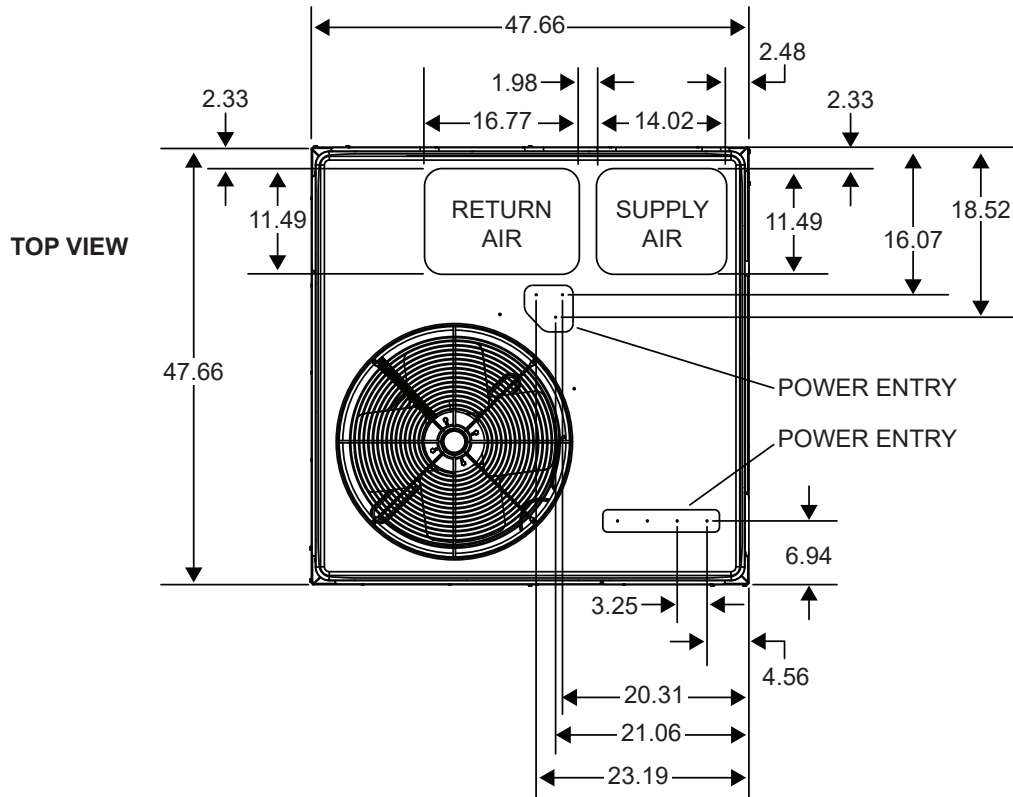

SIDE VIEWS

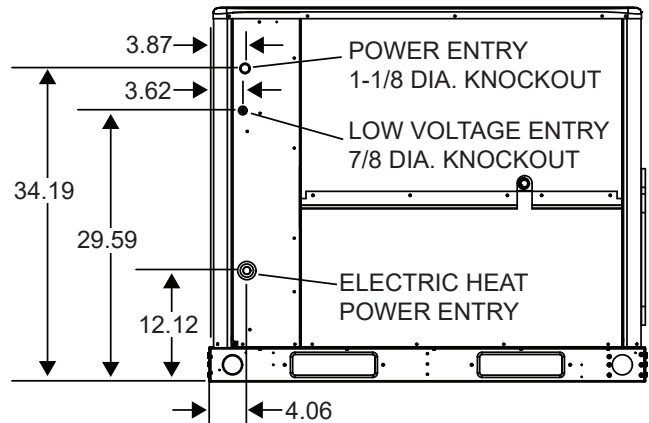
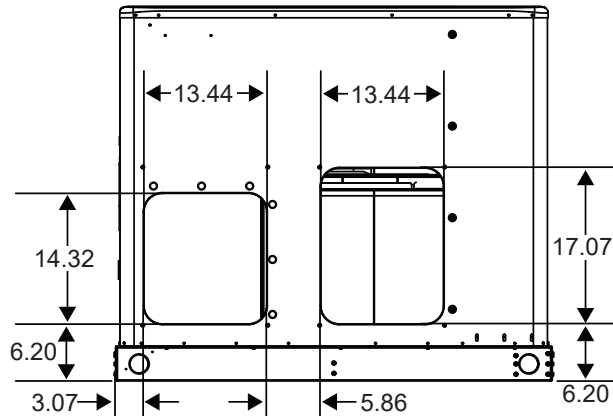
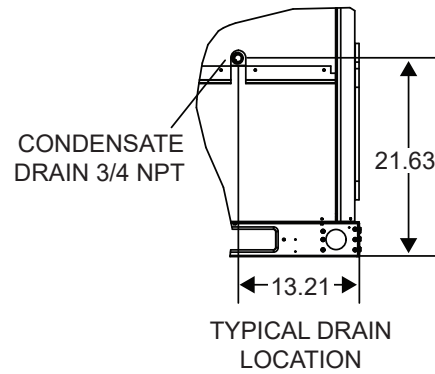
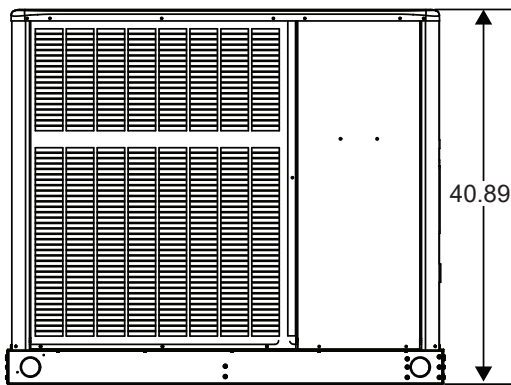

DIMENSIONS (IN.) - LARGE BASE

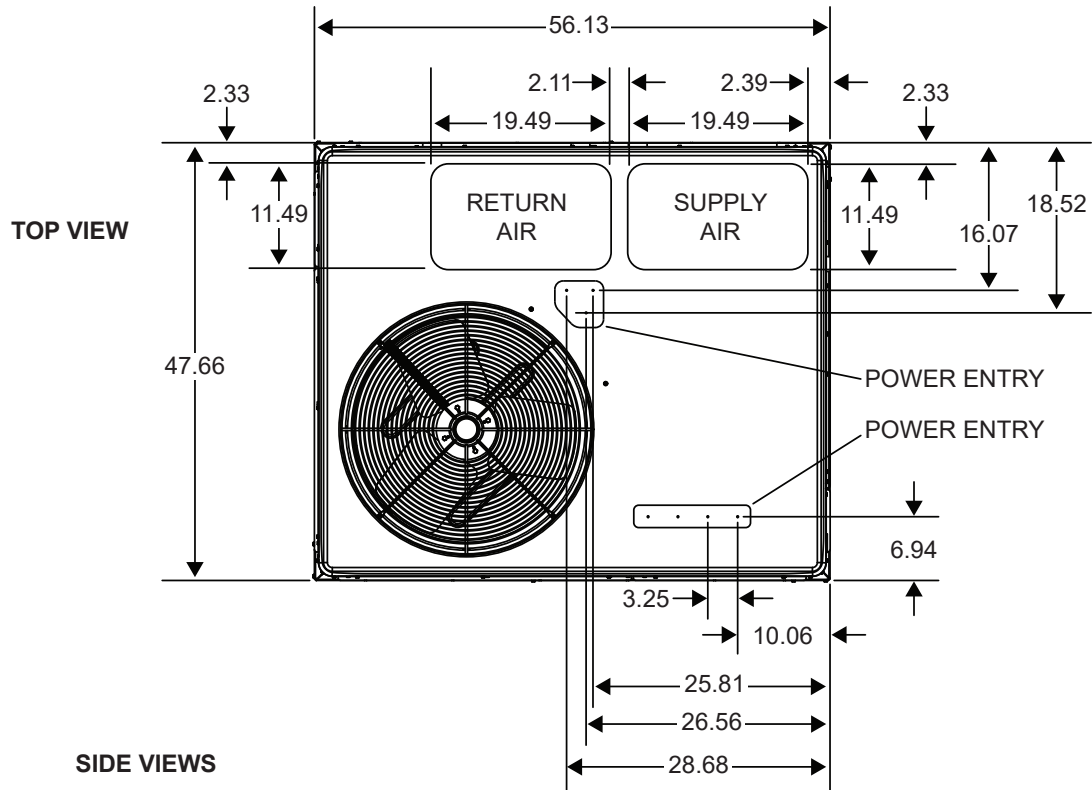

SIDE VIEWS

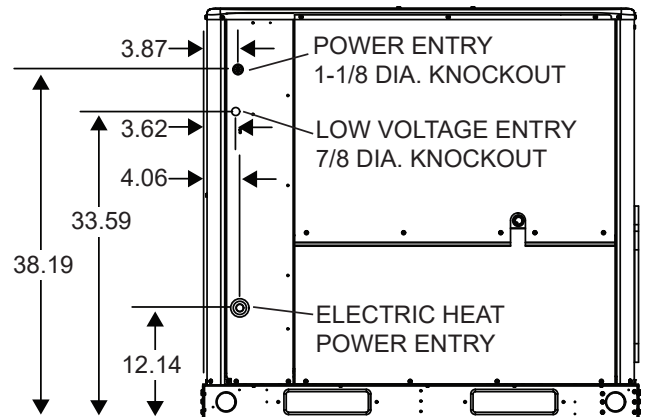
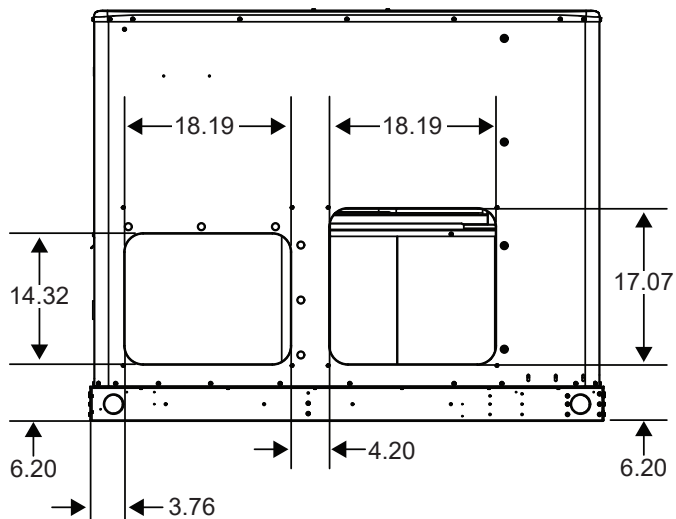
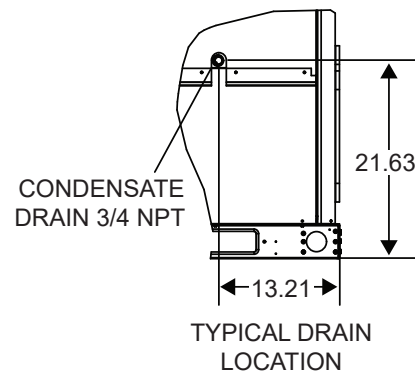
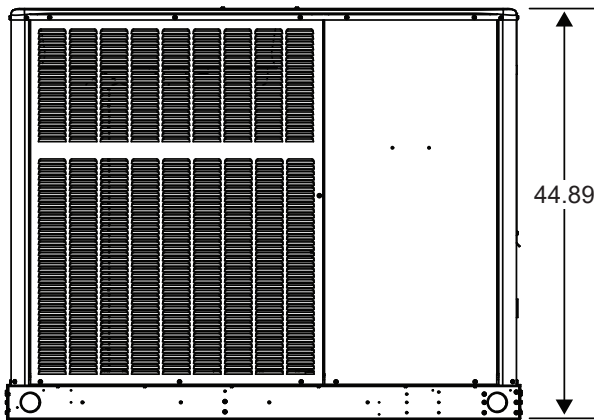

ROOF CURB DIMENSIONS - SMALL BASE

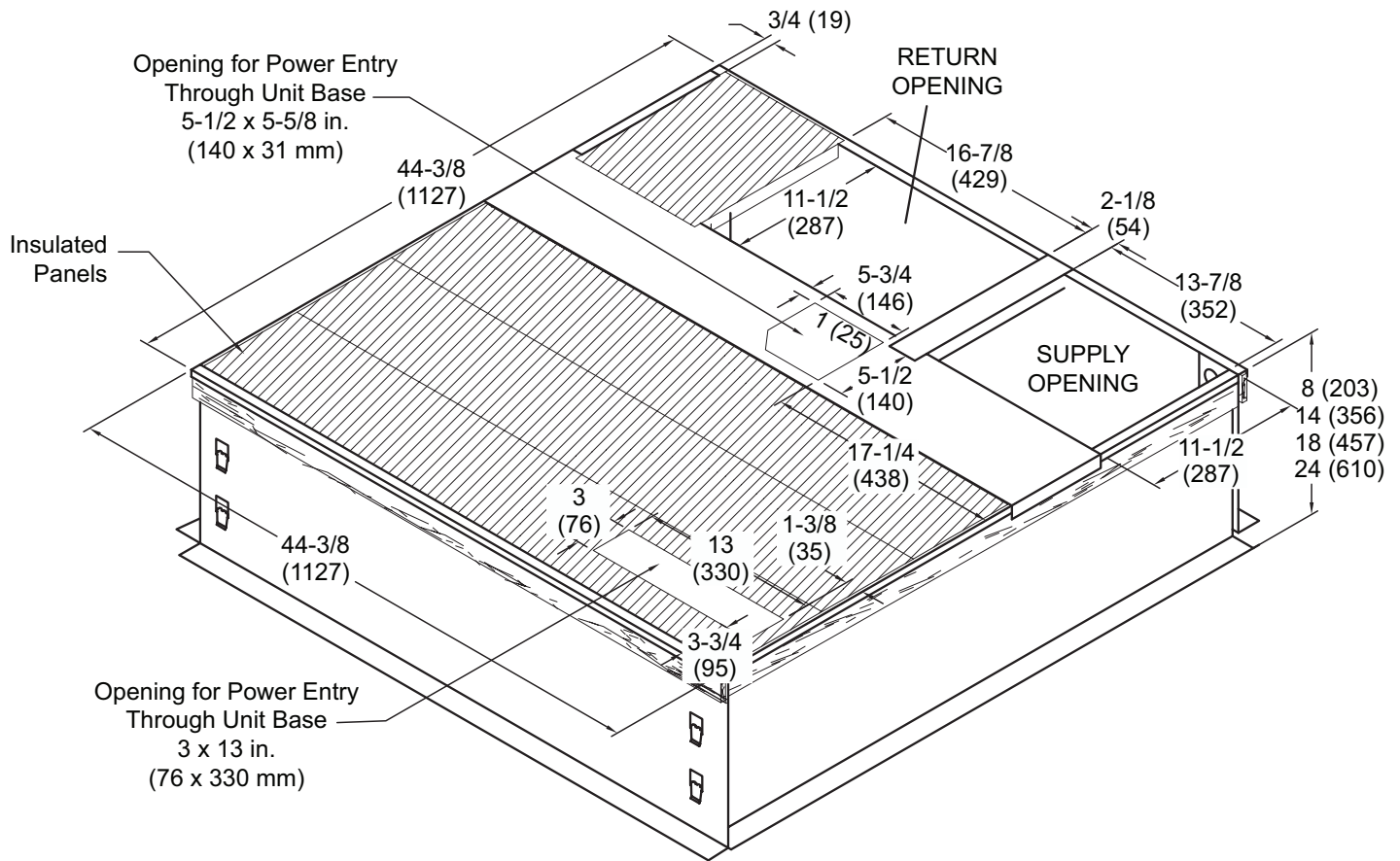

NOTE - Roof deck may be omitted within confines of curb.

NOTE - All Curbs::

- IBC 2018 compliant
- CBC 2019 compliant
- Seismic rating - SDS 2.0g, z/h=1, I_p=1.5
- Wind rating - 240 mph (Lateral), 214 mph (Uplift)
- Maximum load rating - 800 lbs.
- Tool-less filter access panels NOT for seismic-rated applications

ROOF CURB DIMENSIONS - LARGE BASE

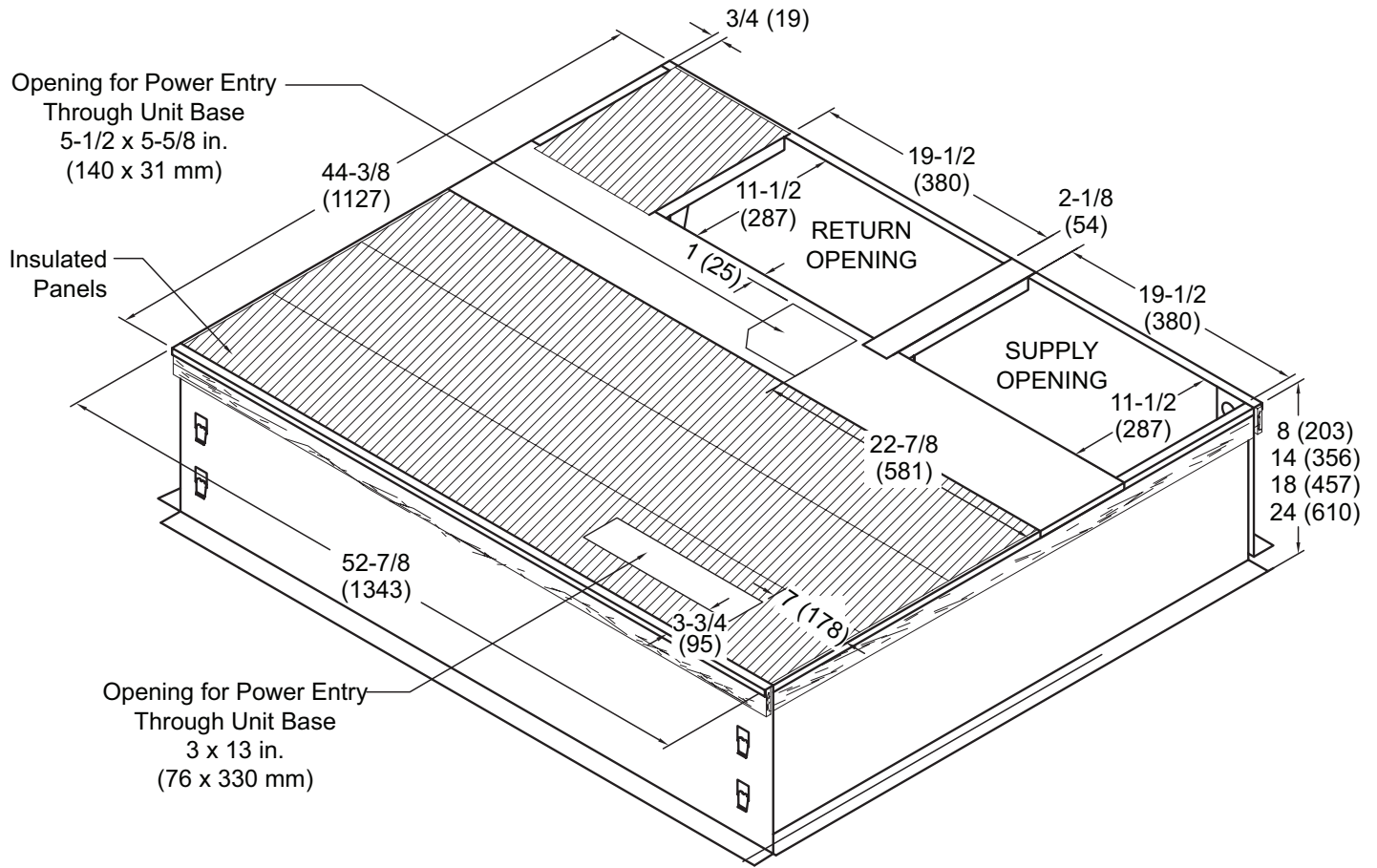

NOTE - Roof deck may be omitted within confines of curb.

NOTE - All Curbs::

- IBC 2018 compliant
- CBC 2019 compliant
- Seismic rating - SDS 2.0g, z/h=1, Ip=1.5
- Wind rating - 240 mph (Lateral), 214 mph (Uplift)
- Maximum load rating - 800 lbs.
- Tool-less filter access panels NOT for seismic-rated applications

ADJUSTABLE CURB (KNOCK-DOWN STYLE) DIMENSIONS - SMALL BASE

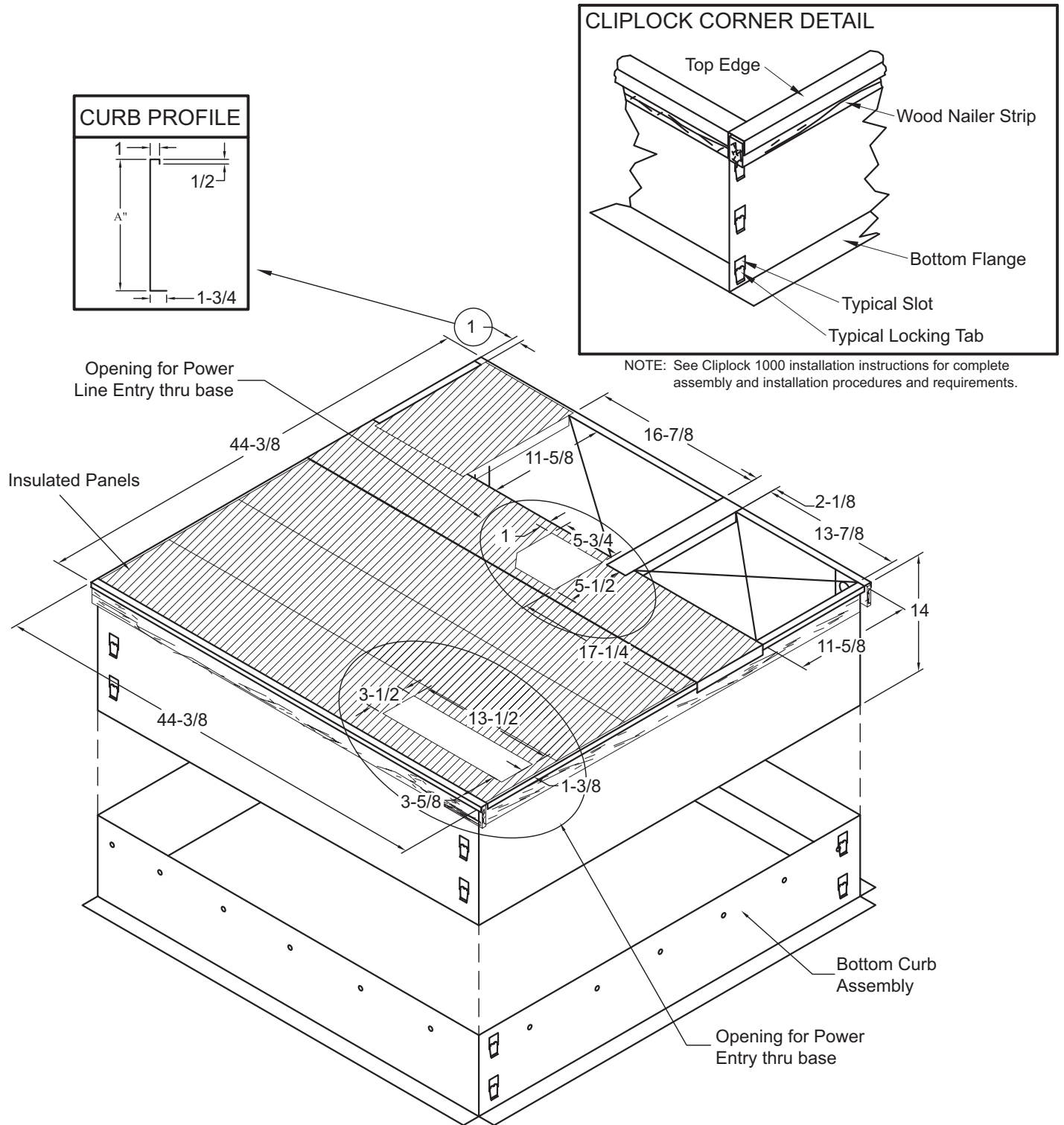

NOTE - Roof deck may be omitted within confines of curb.

NOTE - All Curbs::

- IBC 2018 compliant
- CBC 2019 compliant
- Seismic rating - SDS 2.0g, z/h=1, I_p=1.5
- Wind rating - 240 mph (Lateral), 214 mph (Uplift)
- Maximum load rating - 800 lbs.
- Tool-less filter access panels NOT for seismic-rated applications

ADJUSTABLE CURB (KNOCK-DOWN STYLE) DIMENSIONS - LARGE BASE

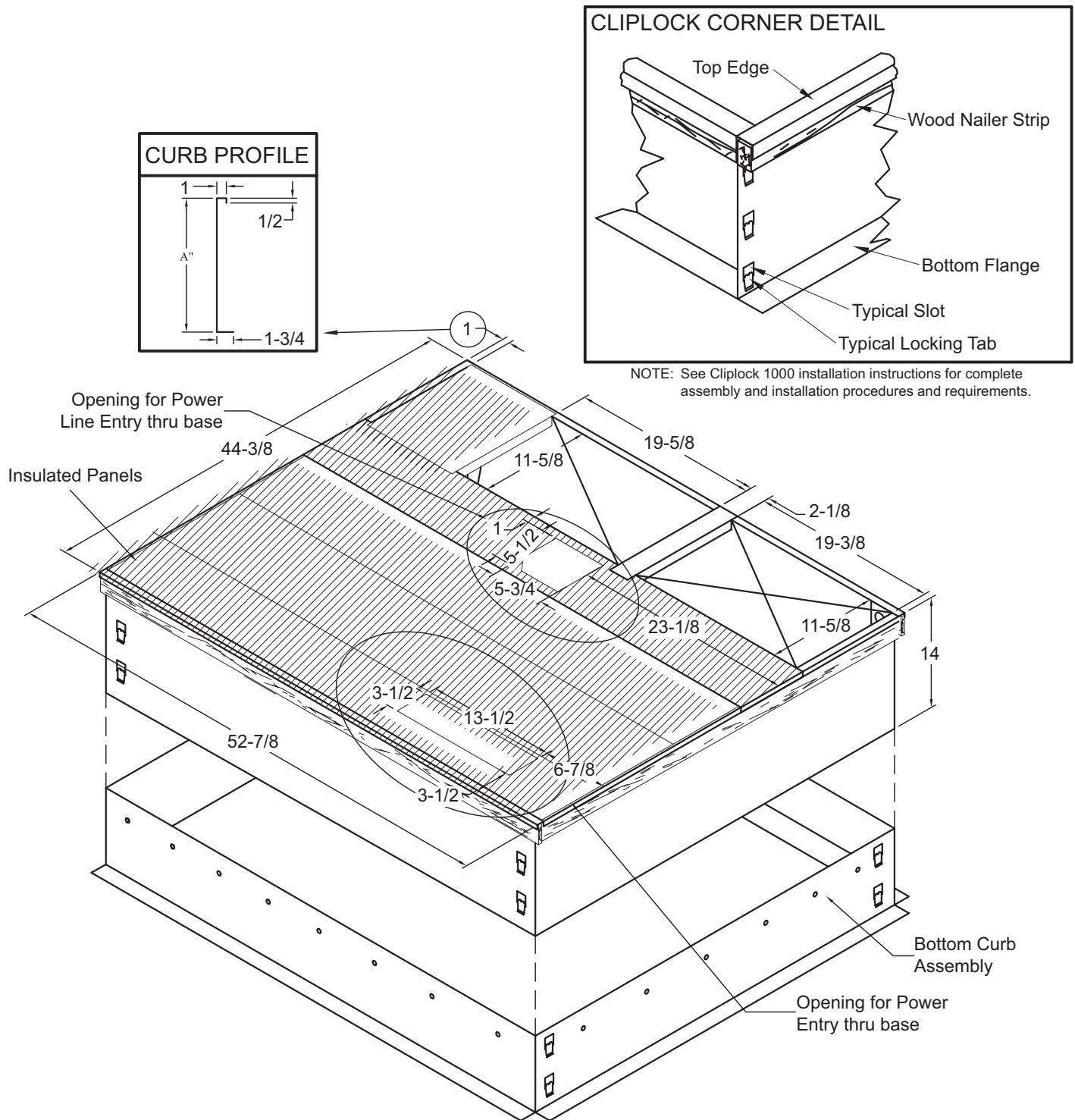

NOTE - Roof deck may be omitted within confines of curb.

NOTE - All Curbs::

- IBC 2018 compliant
- CBC 2019 compliant
- Seismic rating - SDS 2.0g, z/h=1, I_p=1.5
- Wind rating - 240 mph (Lateral), 214 mph (Uplift)
- Maximum load rating - 800 lbs.
- Tool-less filter access panels NOT for seismic-rated applications

ADJUSTABLE CURB (WELDED STYLE) DIMENSIONS

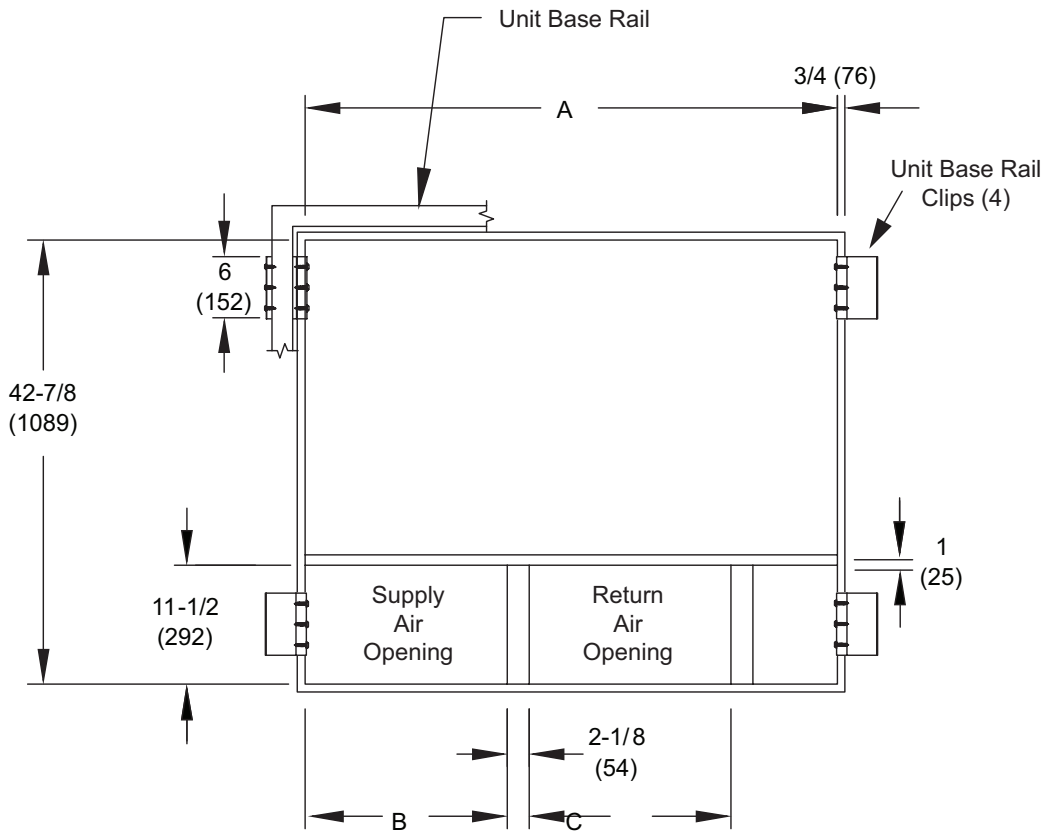
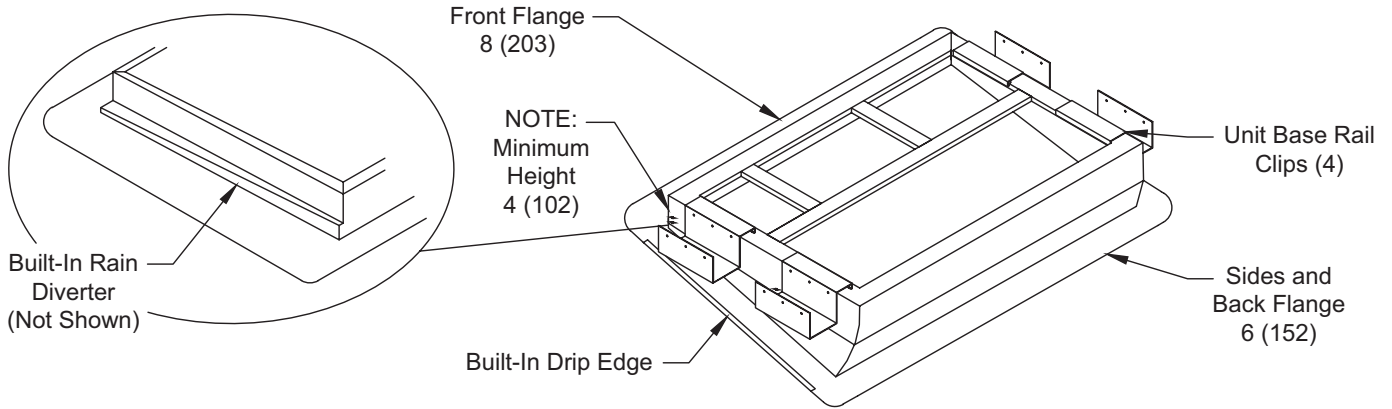

Usage	A		B		C	
	in.	mm	in.	mm	in.	mm
24,30,36	42-7/8	1089	13-7/8	352	16-7/8	429
42,48,60	51-3/8	1305	19-1/2	495	19-1/2	495

ACCESSORIES

Description		Where Used	Kit Number
Compressor Crankcase Heater		All	11X27
Compressor Hard Start Kit		24, 30	10J42
		36, 42, 48, 60	88M91
Compressor Timed-Off Control		All	47J28
Low Ambient Kit		All	21D20
Electric Heater 5kW - PHK05BP		All	10W47
Electric Heater 7.5kW - PHK07BP		All	10W48
Electric Heater 10kW - PHK10BP		All	10W49
Electric Heater 15kW - PHK15BP		36, 42, 48, 60	10W50
Electric Heater 20kW - PHK20BP		42, 48, 60	10W51
Internal Filter Rack Kit		24, 30, 36	11U73
		42, 48, 60	11U74
8" Height Full Perimeter Curb		24, 30, 36	21J13
		42, 48, 60	21J17
14" Height Full Perimeter Curb		24, 30, 36	21J14
		42, 48, 60	21J19
18" Height Full Perimeter Curb		24, 30, 36	21J15
		42, 48, 60	21J20
24" Height Full Perimeter Curb		24, 30, 36	21J16
		42, 48, 60	21J25
Adjustable Pitch Roof Curb (Knock-Down Style)		24, 30, 36	21J26
		42, 48, 60	21U04
Adjustable Pitch Roof Curb (Welded Style)		24, 30, 36	22V54
		42, 48, 60	22V55
Strapping Kit - Hurricane		Slab	21J74
		Rail	22G53
Strapping Kit - Seismic		All	21J75
Duct Adapter Kit - Horizontal	14 in. dia.	24, 30, 36	21J92
	14 in. dia.	42, 48, 60	21D24
	16 in. dia.	42, 48, 60	22U78
	18 in. dia.	42, 48, 60	22U79
Duct Adapter Kit - Downflow	14 in. dia.	24, 30, 36	20X82
	14 in. dia.	42, 48, 60	21D26
Bottom Power Entry Kit		All	21J78
Base Rail Openings - Closure Kit		All	21J84
Single Point Power - 5kW ASPWR813-1		All	13W88
Single Point Power - 7.5 kW ASPWR814-1		All	13W89
Single Point Power - 10kW ASPWR815-1		All	13W90
Single Point Power - 15-20kW ASPWR816-1		36, 42, 48, 60	13W91

All specifications and illustrations subject to change without notice and without incurring obligations.