

DO NOT SKIP

Confirm These 5 Things Before You Begin:

- Electrical voltage verified at the disconnect (110V vs 208/240V)
- Correct breaker size installed
- Line set **length and diameter** is correct for the installation
- Indoor unit type matches outdoor model
- Wall penetration location confirmed (no studs, pipes, wiring)

TOOLS & MATERIALS LIST

REQUIRED

TOOLS Hand

- Tools:
- 5mm allen wrench (hex key) - for valve caps
 - Adjustable wrench set or standard wrench set
 - Phillips and flathead screwdrivers
 - Level (for indoor unit mounting)
 - Measuring tape
 - Stud finder

Power Tools:

- Power drill with drill bits
- Hole saw (2.5" to 3" diameter for wall penetration)
- Masonry bit (if drilling through brick/concrete)

Electrical Tools:

- Wire strippers
- Wire cutters
- Voltage tester/multimeter
- Wire nuts and electrical tape

REQUIRED MATERIALS

- PVC electrical tape (for bundling line set)
- Zip ties
- Mounting screws and anchors (appropriate for wall type)
- Putty or sealant (for wall penetration)
- Soapy water solution (for leak testing) - dish soap and water in spray bottle

SAFETY EQUIPMENT

- Safety glasses (REQUIRED for refrigerant work)
- Work gloves
- Dust mask (for drilling)
- Ladder (appropriate height for unit location)

OPTIONAL BUT RECOMMENDED

- Camera or smartphone (for documenting installation steps)

△ CHECK INCLUDED ITEMS

Your mini-split system should include: indoor unit, outdoor unit, pre-charged line set, remote control, mounting plate, drain hose, and installation hardware. Verify all components are present before beginning installation.

△ BEFORE YOU BEGIN △

PRE-CHARGED LINE SETS CANNOT BE MODIFIED

- Line sets come pre-charged with refrigerant at the factory Lines CANNOT be shortened
- Cutting the lines will release refrigerant and make the system no longer a DIY system
- MEASURE your installation distance carefully before ordering
- If line set is too short, you must order a different length
- If line set is too long, excess must be coiled horizontally

VERIFY SYSTEM COMPATIBILITY BEFORE INSTALLATION

- Confirm indoor unit model and outdoor unit model are compatible
- Check that line set size matches both units (see specification sheet)
- Verify voltage requirements match your electrical service (120V or 240V)
- Confirm BTU capacity is appropriate for your space size

ELECTRICAL REQUIREMENTS

- Installation requires dedicated circuit with proper amperage
- Circuit breaker must be sized per unit specifications
- Wire gauge must meet or exceed minimum requirements
- All electrical work must comply with National Electrical Code (NEC)
- Contact licensed electrician if you are uncertain about requirements

WHEN TO STOP AND CALL A PROFESSIONAL

Do NOT proceed with installation if any of the following apply:

You are uncomfortable working with electrical wiring
Local building codes require licensed HVAC contractor installation
Your installation requires custom electrical panel modifications

REQUIRED SKILLS AND KNOWLEDGE

This installation requires

- ✓ Basic hand tool proficiency
- ✓ Ability to drill through exterior walls
- ✓ Understanding of electrical wiring basics (or licensed electrician)
- ✓ Physical ability to lift 55-152 lbs (outdoor unit weight)

INSTALLATION TIME ESTIMATE

Plan for 4-6 hours total for first-time installation:

- Indoor unit mounting: 1-2 hours
- Line set routing and connection: 2-3 hours
- Electrical connections: 1 hour
- Testing and startup: 30 minutes

PERMIT REQUIREMENTS CHECK

LOCAL REQUIREMENTS

- Many jurisdictions require permits for HVAC installation
- Some areas require licensed contractor regardless of DIY capability Building inspection may be required before startup
- **Contact your local building department BEFORE beginning work**

SAFETY WARNINGS

⚠ REFRIGERANT SAFETY

- R454B refrigerant is factory sealed under high pressure.
- NEVER loosen or remove refrigerant connections while system is charged
- Always wear safety glasses when working near refrigerant connections
- Work in well-ventilated area - refrigerant displaces oxygen in confined spaces
- & R454B REFRIGERANT - A2L CLASSIFICATION
This system uses R454B refrigerant, classified as A2L (mildly flammable).
Critical safety requirements:
- Work in well-ventilated areas - Never work in enclosed spaces without adequate airflow. Refrigerant displaces oxygen and can ignite if exposed to open flames or sparks
- No ignition sources - Keep away from lit cigarettes, pilot lights, welding equipment, or any flames during installation
- If leak suspected - If you smell a sweet/ether-like odor or notice unusual ice forming, evacuate and ventilate the area for at least 15 minutes before re-entering
- Important for DIY installation:
- Use only the soapy water leak detection method shown in Step 26
Follow all connection procedures exactly as shown
Never attempt to modify, cut, or recharge the refrigerant system
If you suspect a leak after installation, contact a certified HVAC technician immediately
- Remember: Venting refrigerant is illegal (EPA violation, \$10,000+ fine) and creates both environmental and safety hazards.

⚠ ELECTRICAL SAFETY

- **Turn OFF power at circuit breaker before making any electrical connections**
- Verify power is off with voltage tester before touching wires
- Do not work on live electrical circuits
- Follow all local electrical codes

WARRANTY CONSIDERATIONS

- Improper installation VOIDS manufacturer warranty
- (Recommended) TAKE PHOTOS of each installation step.
This is done to assist any potential troubleshooting and to help confirm proper installation
- Keep all packaging, documentation, and receipts



DS1, DS2, DS3 DIY QUICK INSTALL

DS1 DS2 DS3 DIY Ductless Mini-Split for Heating & Cooling

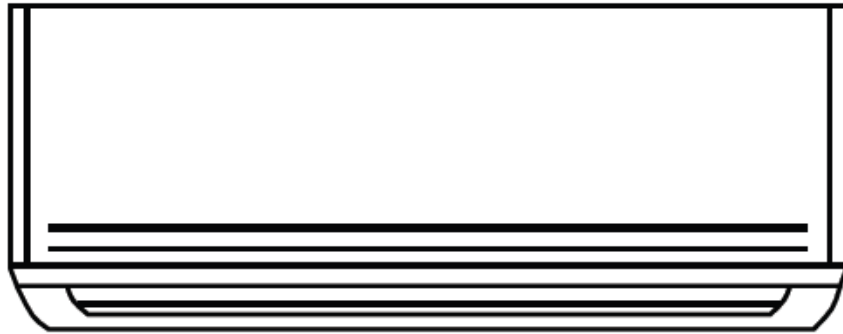

MODELS

- BDS1A09SCV-9WMV
- BDS1A12SCV-12WMV
- BDS1A18SC0-18WM
- BDS1A24SC0-24WM
- BDS2A09SCV-9WMV
- BDS2A12SCV-12WMV
- BDS2A18SC0-18WM
- BDS2A24SC0-24WM
- BDS2A36SC0-36WM
- BDS3A12UC0-12WM
- BDS3A18UC0-18WM

www.AlpineHomeAir.com

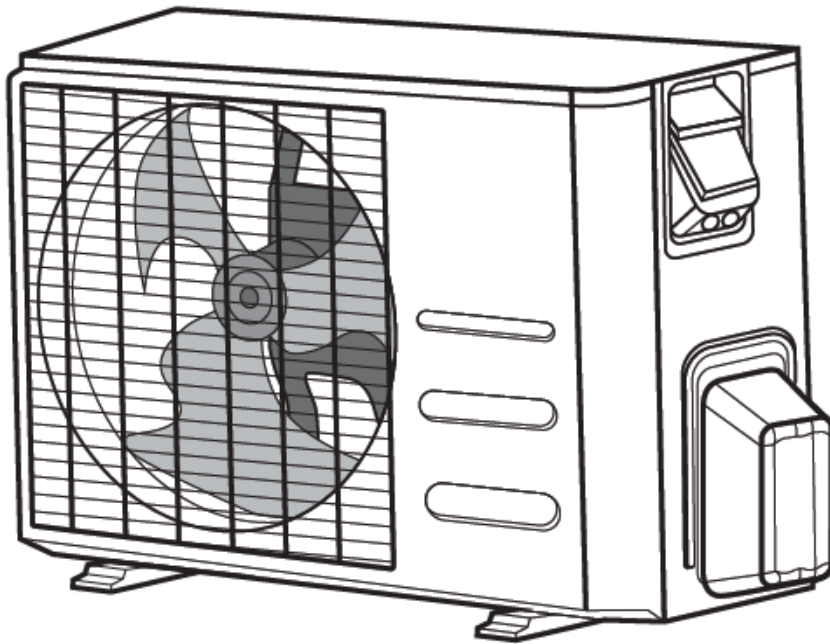

PREP FOR INSTALL

1

Choose the place for the indoor unit on an exterior (outermost) wall.

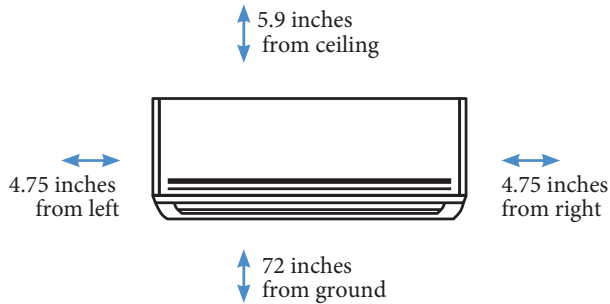

! **Maintain listed clearances**

If you select not to install the air handler on an exterior wall, please see full Owner & Install manual .

2

Choose the location to place the outdoor unit.

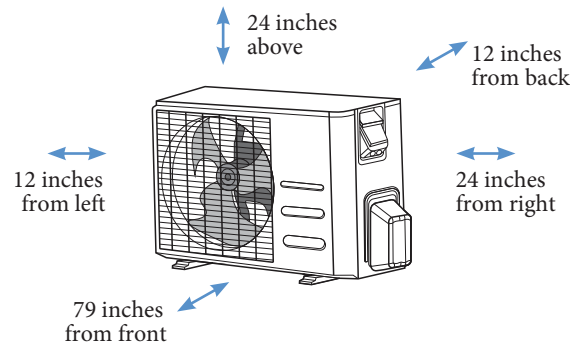

! **Maintain listed clearances**

3

Prior to running the electrical, verify the voltage and max breaker of your system.

- DIY mini splits can be either 110/120 or 208/240 voltage depending on the model.
- Max breaker size varies by model.

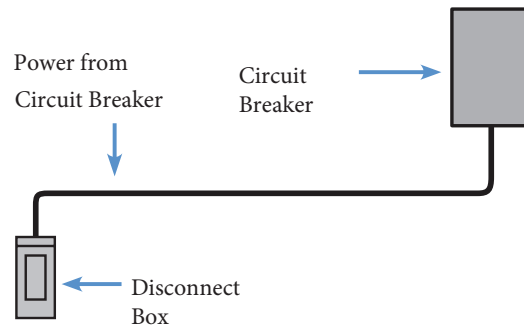

INDOOR UNIT

4

Remove the mounting bracket from the back of the indoor unit and mount it to the wall using the included hardware

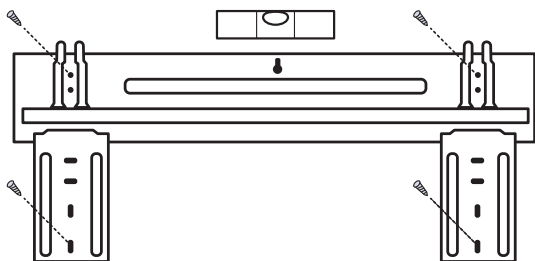

! Bracket must be horizontally level.

5

Mark the position of the large hole for the connecting line set and wires.



By default, the line set will exit the indoor unit on the right side (facing the unit).

If you wish to alter the configuration of the line set, please see full Owner & Install manual.

6

Drill hole through the wall, maintaining a slight pitch downwards to aid outside drainage.

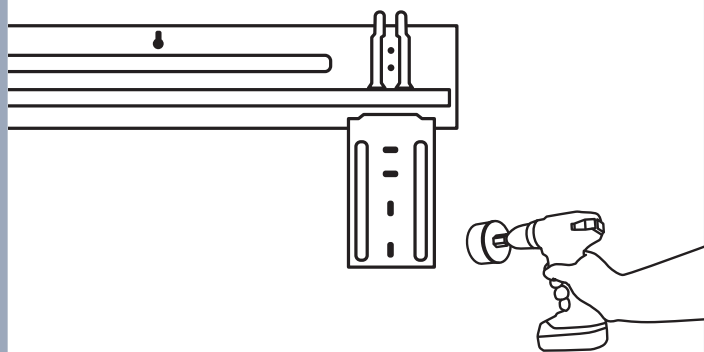

! Hole must be free of electrical wiring, plumbing, or other obstructions.

7

Insert wall sleeve through the wall with the flange facing the exterior.

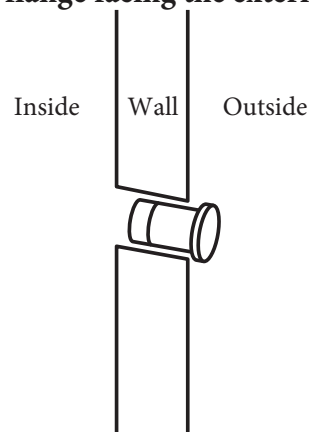

If you can't maintain a downwards pitch, you must install a condensate pump.

8

Remove wire cover on front of indoor unit.

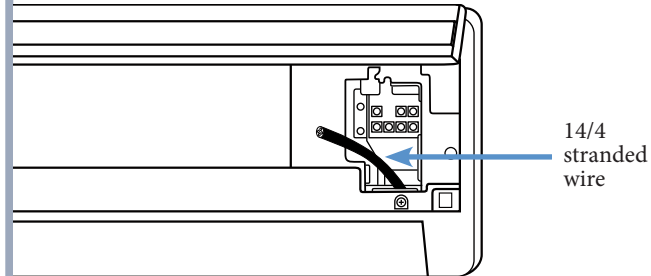

Feed 14/4 stranded wire from the back of the unit to the front.

9

Connect wires to indoor unit.

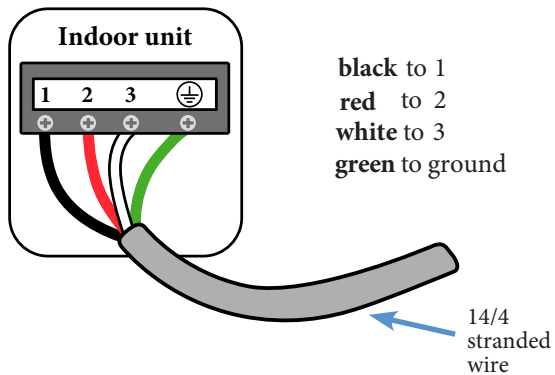

10

Identify the larger refrigerant pipe.

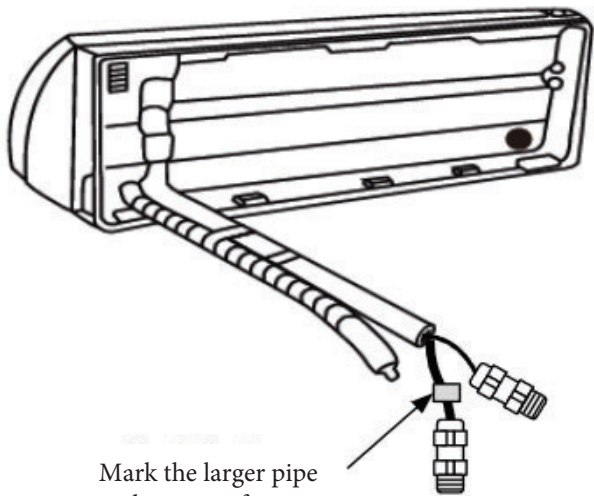

Identify which line set connection has the larger pipe. Then mark the larger pipe by wrapping it once with colored tape.

11

Attach the drain hose and prepare the connecting line set, drain, and wires.

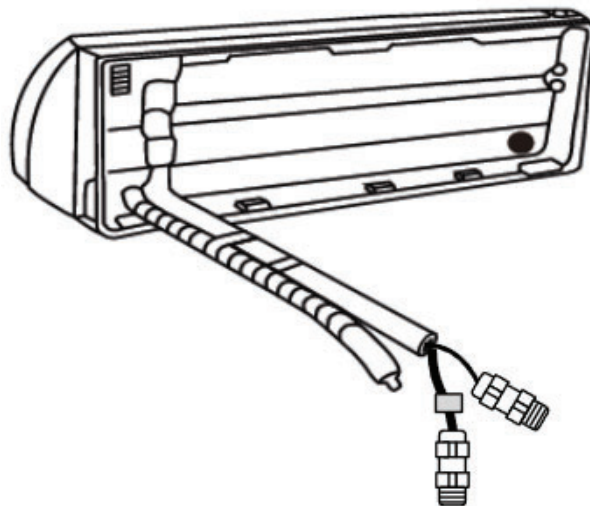

For most installations, the line set will be bent 90° to exit through the wall (as shown above).

12

Bundle the line set, drain, and connection wires together, keeping drain line on bottom.

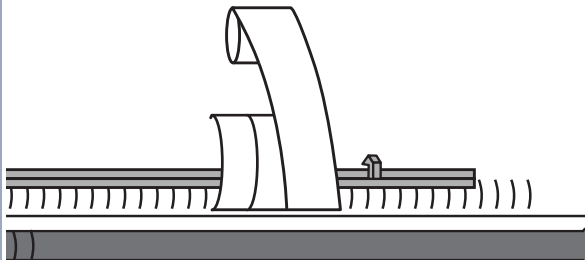

Use PVC electrical tape to secure every 3-4 feet, then install zip ties over taped sections.



Do not overtighten tape and zip ties, as that will crimp the line set.

Blueridge DIY mini splits come with pre-charged refrigerant lines and can not be shortened or extended.

INDOOR UNIT

13

Hang the indoor unit on the mounting bracket.

Feed the bundled connection lines through the hole to the outside.

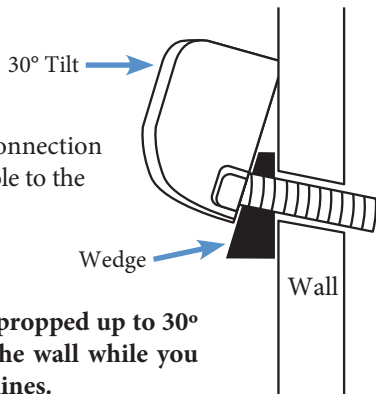

Unit can be propped up to 30° away from the wall while you manage the lines.

14

Bend the line set on the exterior of the wall towards the outdoor unit.

Run the drain tubing to the ground, at least 12 inches from the structure.

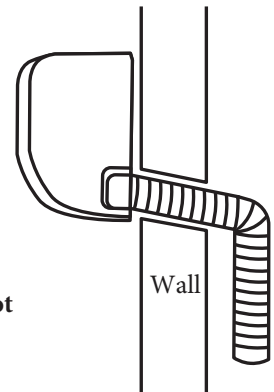

When bending, do not kink the line set.

With lines larger than 3/8 inch OD, using a tubing bender is recommended.

OUTDOOR UNIT

15

Mount on a pad, bracket, or stand.



Position the outdoor unit so it is blowing away from the structure.

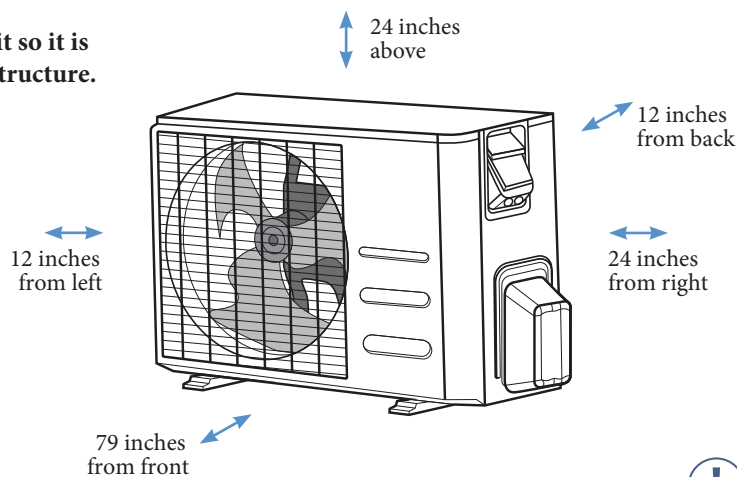

Maintain listed clearances

0224 QIS101-01

⚠ TOP 5 DIY INSTALLATION MISTAKES (READ BEFORE CONTINUING)

These are the most common issues that cause leaks, poor performance, or warranty problems. Review carefully before proceeding.

1. Opening Service Valves Too Early

Risk: Refrigerant release, leaks, warranty issues Avoid it:

Do not open valves until:

Both line-set connections are fully seated Leak test shows no bubbles

Line set is supported and not pulling on fittings

✓ Complete the checklist in Step 27 first.

2. Cross-Threaded or Improperly Seated Line Sets

Risk: Refrigerant leaks, internal valve failure

Avoid it:

Start all fittings by hand

If resistance is felt immediately, stop and realign Use two wrenches (hold + tighten)

Tighten only until fully seated against the mechanical stop

⚠ Do not overtighten or use torque values.

3. Incorrect Drain Line Slope

Risk: Water leaks, interior damage, mold

Avoid it:

Maintain a continuous downward slope

No traps, kinks, or uphill sections

Keep drain line below bundled line set

Use a condensate pump if downward pitch cannot be maintained

4. Electrical Wiring Errors

Risk: No startup, breaker trips, board damage Avoid it:

Confirm system voltage (110/120V vs 208/240V) Match wire numbers and colors exactly

Verify LINE vs LOAD in the disconnect

Turn power OFF at the breaker before wiring

⚠ Stop and contact an electrician if unsure.

5. Improper Outdoor Unit Placement

Risk: Reduced efficiency, noise, premature wear

Avoid it:

Maintain all required clearances

Install on a level pad, bracket, or stand

Ensure airflow blows away from the structure

Keep unit clear of snow, debris, and vegetation

IMPORTANT

If anything feels unclear, forced, or unexpected:

STOP and contact technical support or a licensed professional. Proceeding incorrectly may cause system damage, safety hazards, or loss of warranty coverage.

- ⚠️ Any high voltage electrical installation should be performed by an electrician or contractor.
- Make sure the electricity is off.
- Follow all local and national electrical codes.
- Always verify line and load lug locations on the disconnect prior to wiring.
- Wiring shown is based on the disconnect box terminals labeled load, line, line, load.

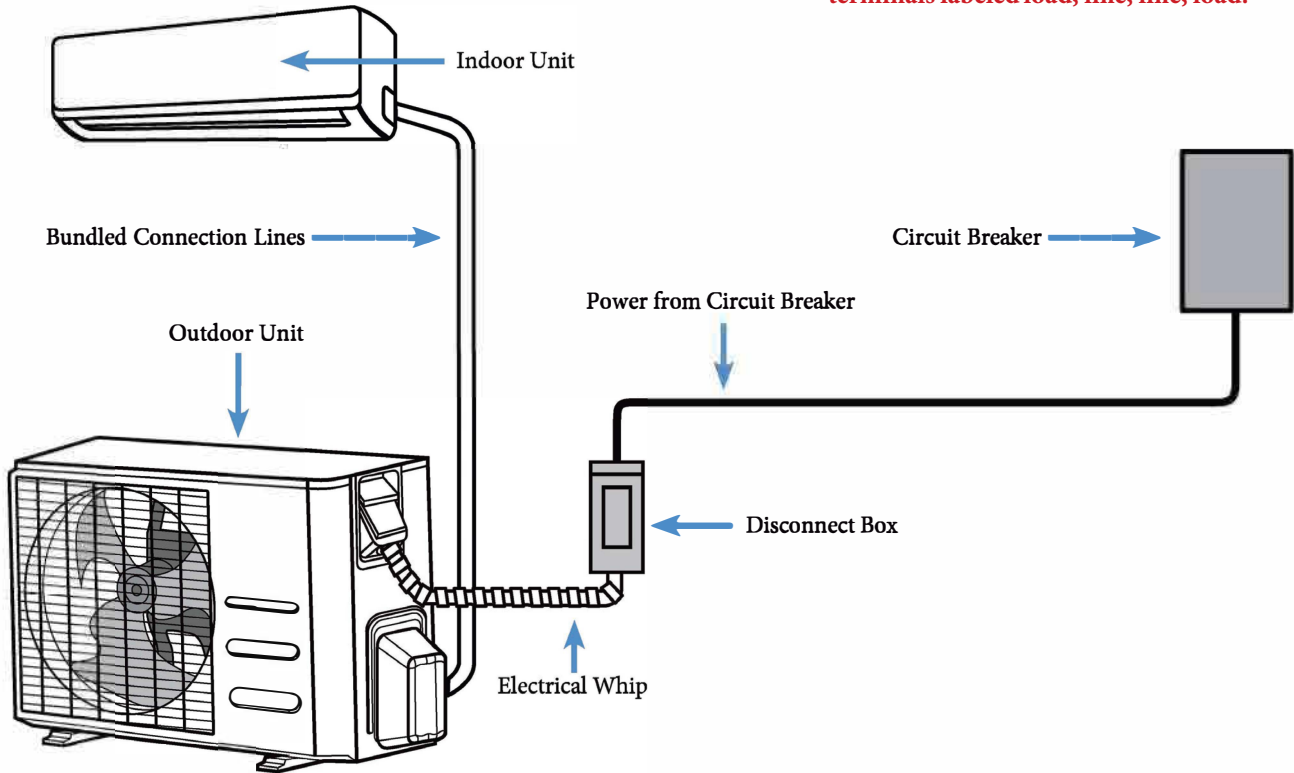

16

Using correct size breaker and wire, run the power to the disconnect box mounted beside the outside unit.

- Connect the indoor unit to the outdoor unit.
- Connect the outdoor unit to the disconnect box with the electrical whip.

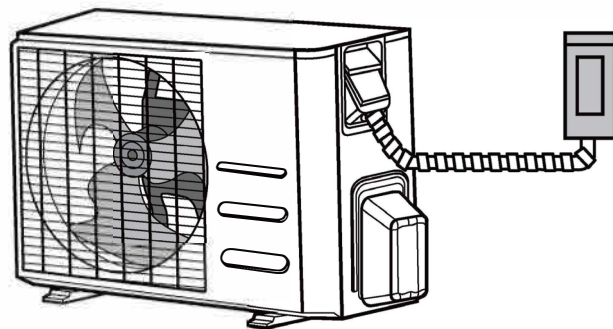

⚠️ See next page for wiring diagrams

Terminal layout may vary by disconnect model — always confirm LINE and LOAD markings. This configuration is used in the wiring diagrams shown.

⚠ Turn OFF power at the breaker before wiring the disconnect.

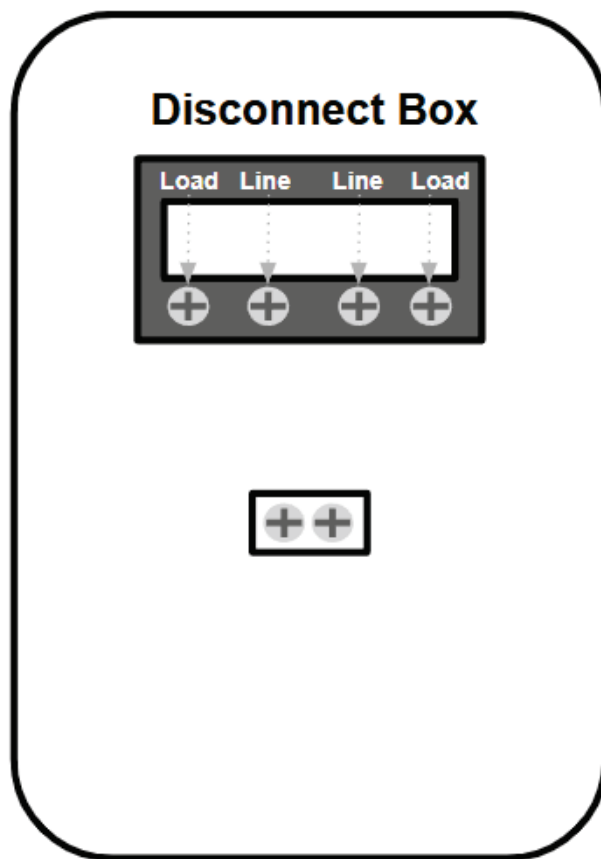

Line = Power coming from the breaker

Load = Power going to the outdoor unit

FOR 208/240 VOLT SYSTEM

17

Connect indoor unit to the outdoor unit.

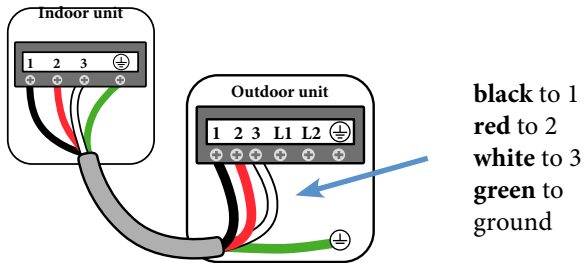

Connect incoming power from the electrical panel to the LINE terminals.



Connect the wires going to the outdoor unit to the LOAD terminals.

Wiring shown is based on load, line, line, load at the disconnect. Check your disconnect prior to wiring.

18

Connect outdoor unit to disconnect box.

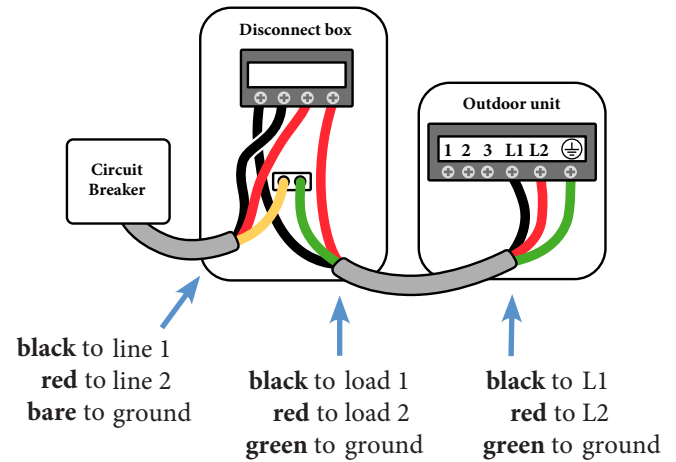

FOR 110/120 VOLT SYSTEM

19

Connect indoor unit to the outdoor unit.

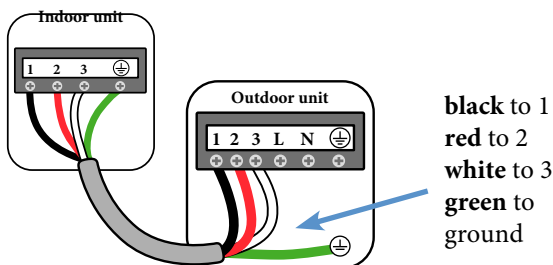

20

Connect outdoor unit to disconnect box.

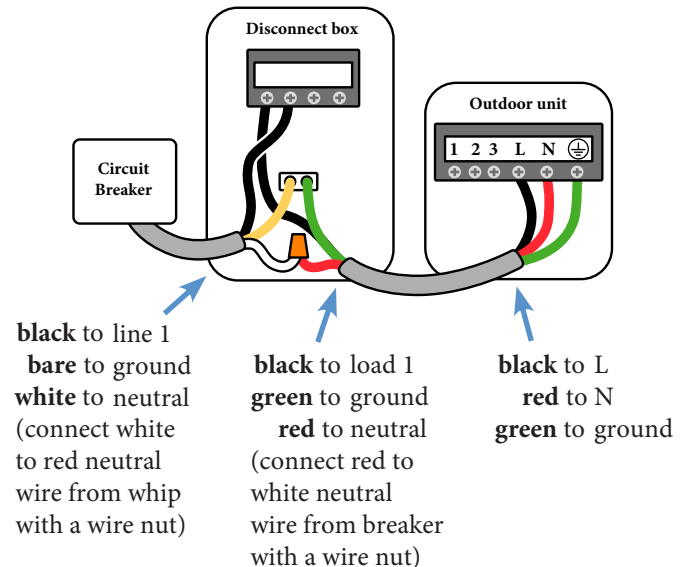

Line Set Connections Indoor Unit

21

Remove the colored caps from the line set connections on the indoor air handler and the refrigerant lines. **IGNORE THE COLOR OF THE CAPS.**

Male connection
on the indoor unit

Female
connection on the
line set

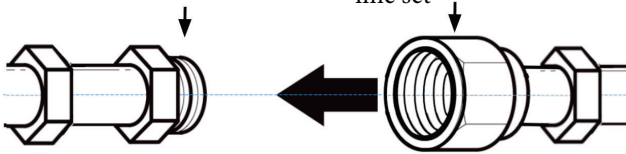

22

Check the line set. **The larger diameter line must attach to the larger pipe** (that you marked earlier) on the air handler.

The smaller diameter line must attach to the smaller pipe connected to the indoor air handler.

Male connection
on the indoor unit

Female
connection on the
line set

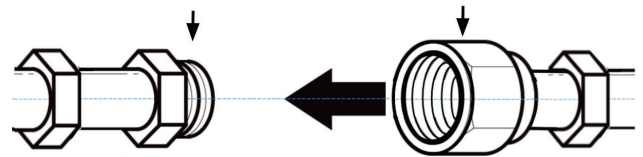

! Warning: Refrigerant handling should be done by a trained professional.

23

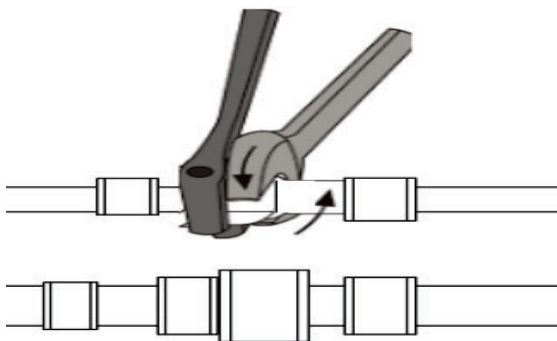

Position the line set fitting squarely onto the outdoor unit connection and begin threading by hand. The fitting should start smoothly. If resistance is felt immediately, stop and realign the connection to avoid cross-threading.

Once the threads are fully engaged, use two standard wrenches — one to hold the stationary fitting and one to tighten the line-set nut.

Tighten the connection until it is fully seated against the mechanical stop and no gap remains between the mating surfaces.

Do not attempt to tighten to a specific torque value. When properly seated, the internal valve will open and seal automatically.

! Do not over-tighten — once the fitting is fully seated, additional force will not improve sealing.

24

Remove the colored caps from the line set connections on the outdoor unit and the refrigerant lines. **IGNORE THE COLOR OF THE CAPS.**

Check the line set. The larger diameter line must attach to the lower connection on the outdoor. The smaller line set attaches to the upper connection.

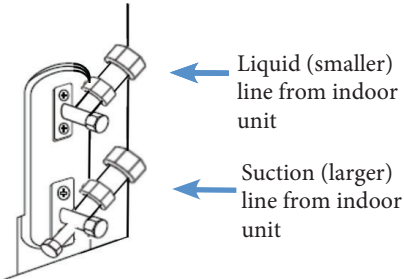

25

Connect your line sets to the outdoor unit

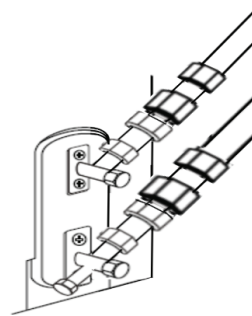

Position the line set fitting squarely onto the outdoor unit connection and begin threading by hand.

The fitting should start smoothly. If resistance is felt immediately, stop and realign the connection to avoid cross-threading.

Once the threads are fully engaged, use two standard wrenches — one to hold the stationary fitting and one to tighten the line-set nut.

Tighten the connection until it is fully seated against the mechanical stop and no gap remains between the mating surfaces.

Do not attempt to tighten to a specific torque value.

When properly seated, the internal valve will open and seal automatically.



Do not over-tighten — once the fitting is fully seated, additional force will not improve sealing.

26

Check your connections for leaks.

Spray all refrigerant connections with a soapy water solution and observe closely for bubbles.

If bubbles are present, re-seat the connection without disconnecting the line set, then recheck.

If no bubbles are observed, proceed to the next step. If bubbling continues after re-seating the connection, stop and contact technical support. Do not continue tightening or attempt to disconnect the line set.

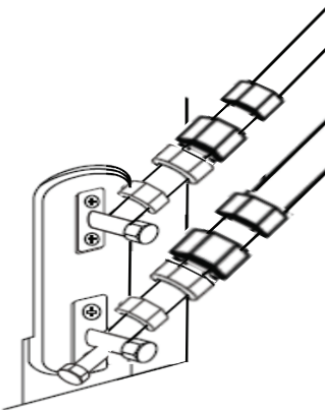

27

Before Opening Service Valves

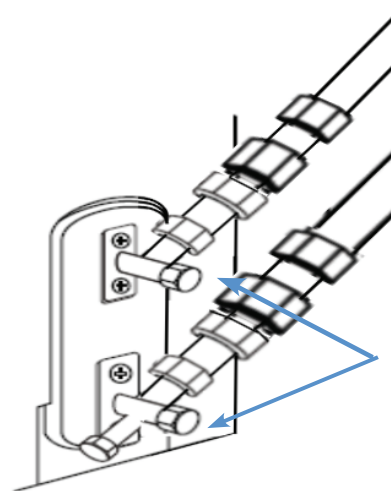

- Both line-set connections fully seated
- No visible gaps at fittings
- Leak check passed
- Line set is not stretched or pulling on the connection

28

Open horizontal facing valve caps.

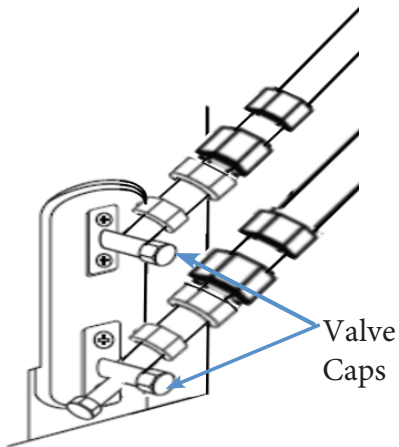

- Use a 5mm allen wrench (hex key) to fully open the lower and then upper valve, releasing the refrigerant into the system.
- Replace caps over open valves.

29

STARTUP & COMMISSIONING

- After opening both service valves: Wait 5 minutes minimum before turning on power
This allows refrigerant to distribute through the system
Listen for any unusual hissing sounds (indicates possible leak)
Verify all valve caps are reinstalled and hand-tight
 - Both valves fully open (turned counterclockwise until they stop)
 - Valve caps reinstalled
 - 5 minutes elapsed
 - No hissing sounds detected

30

Turn on power and perform initial checks.

- Turn on the circuit breaker and observe the outdoor unit:
- Outdoor fan should start within 30-60 seconds Compressor will start shortly after (you'll hear it ramp up) Check for unusual vibrations or grinding sounds.
- At the indoor unit:
- Use remote control to set desired temperature

- For cooling test: Set temperature 5°F below room temperature
- For heating test: Set temperature 5°F above room temperature
- Airflow should begin within 2-3 minutes
Feel the air coming from the unit - temperature change should be noticeable within 5 minutes
Initial checks (first 5 minutes):
 - Both indoor and outdoor units running
 - No unusual sounds (grinding, rattling, squealing)
 - No burning smell from indoor unit
 - Condensate beginning to form on indoor line set (cooling mode)
 - Air temperature changing at indoor unit

△ If you notice burning smell, sparking, or excessive vibration, turn off power immediately at the breaker.

31

Allow system to stabilize (15-20 minutes)

- 0-5 minutes: Refrigerant circulating, temperatures changing
 - 5-15 minutes: Compressor ramping to match demand
 - After 15 minutes: System modulating to maintain setpoint
 - What to observe indoor unit:
 - Variable airflow (fan speed adjusts with demand - normal for inverter systems)
 - Air temp 15-20°F cooler (cooling) or 20-30°F warmer (heating) than room temp
 - Temperature differential decreases to 10-15°F as system approaches setpoint
 - Condensate dripping from drain (cooling mode only) No ice on coil or connections
 - What to observe outdoor unit:
 - Fan and compressor run continuously (inverter systems do NOT cycle on/off)
 - Compressor sound varies with demand (louder/higher pitch at high demand, quieter/lower pitch at low demand)
 - Refrigerant lines at different temperatures:
 - Cooling: Larger line cool/cold; smaller line warm
 - Heating: Larger line warm; smaller line cool/cold
 - No frost or ice on coil (some frost normal in heating mode below 35°F)
- △ NORMAL INVERTER BEHAVIOR:
System runs continuously.
Fan speed and compressor sound constantly adjust with demand

32

Final checks and documentation

Complete these final steps:

Cycle the system:

Turn unit off with remote, wait 5 minutes

Turn back on and verify normal startup

Switch between cooling and heating modes (wait 3-5 minutes between mode changes)

Check remote control functions:

Temperature adjustment (up/down)

Fan speed control (low/medium/high)

Mode selection (cool/heat/dry/fan)

Timer and sleep functions (if applicable)

Document your installation:

Take photos of completed installation (indoor unit, outdoor unit, electrical connections)

Record model numbers and serial numbers from both units

Note the date of installation and first startup

Save all documentation

33

Please call 1.800.865.5931 if you have any questions prior to or during the installation process of your Blueridge Mini-Split System.

Because of the Blueridge promise for continuous product innovation and improvement, some specifications and instructions may change without notification.

