



Air Conditioning & Heating

GLZT7C

HIGH-EFFICIENCY, COMMUNICATING, R-32 SPLIT SYSTEM HEAT PUMP

UP TO 17.2 SEER2 AND 8.2 HSPF2



Contents

Nomenclature.....	2
Product Specifications.....	3
Expanded Cooling Data.....	4
Expanded Heating Data.....	20
Wiring Diagram.....	22
Dimensions	23
Accessories	23



Standard Features

- Two-Stage Copeland® UltraTech scroll compressor
- High-density foam compressor sound blanket
- Integrated communicating ComfortBridge™ technology
- Commissioning and diagnostics via indoor board Bluetooth with the CoolCloud™ phone and tablet application
- Goodman® GTST Connected Thermostat Compatibility
- ComfortAlert™ built in diagnostics
- Copper tube/enhanced aluminum fin coil - 5mm on 2.0-3.0T
- Copper tube/enhanced aluminum fin coil -7mm on 4.0-5.0 T
- Efficient, two-speed ECM condenser fan motor
- Simple low-voltage wiring to outdoor unit in communicating mode
- Diagnostic indicator lights and storage of six fault codes
- Color-coded terminal strip for non-communicating set-up
- High- and low-pressure switches
- Time-delay technology with short-cycle protection to ensure quiet, reliable defrost
- Factory-installed bi-flow liquid-line filter drier
- Factory-installed suction-line accumulator
- Factory-installed compressor crankcase heater
- Factory-installed high-capacity muffler
- Factory-installed coil and ambient temperature sensors
- AHRI Certified; ETL Listed

Cabinet Features

- Grille-style sound control top design
- Custom Nickel Gray powder-paint finish
- 500-hour salt-spray tested
- Wire fan discharge grille
- Steel louver coil guard
- Single panel access to controls
- with space provided for field-installed accessories
- Sweat connection service valves
- with easy access to gauge ports
- When properly anchored, meets the 2024 Florida
- Building Code unit integrity requirements for
- hurricane-type winds (Anchor bracket kits available.)



Products that are recognized as the Most Efficient of ENERGY STAR® in 2024 prevent greenhouse gas emissions by meeting rigorous energy efficiency performance levels set by the U.S. Environmental Protection Agency.





* Proper sizing and installation of equipment is critical to achieve optimal performance. Split system air conditioners and heat pumps must be matched with appropriate coil components to meet ENERGY STAR criteria. Ask your contractor for details or visit www.energystar.gov.

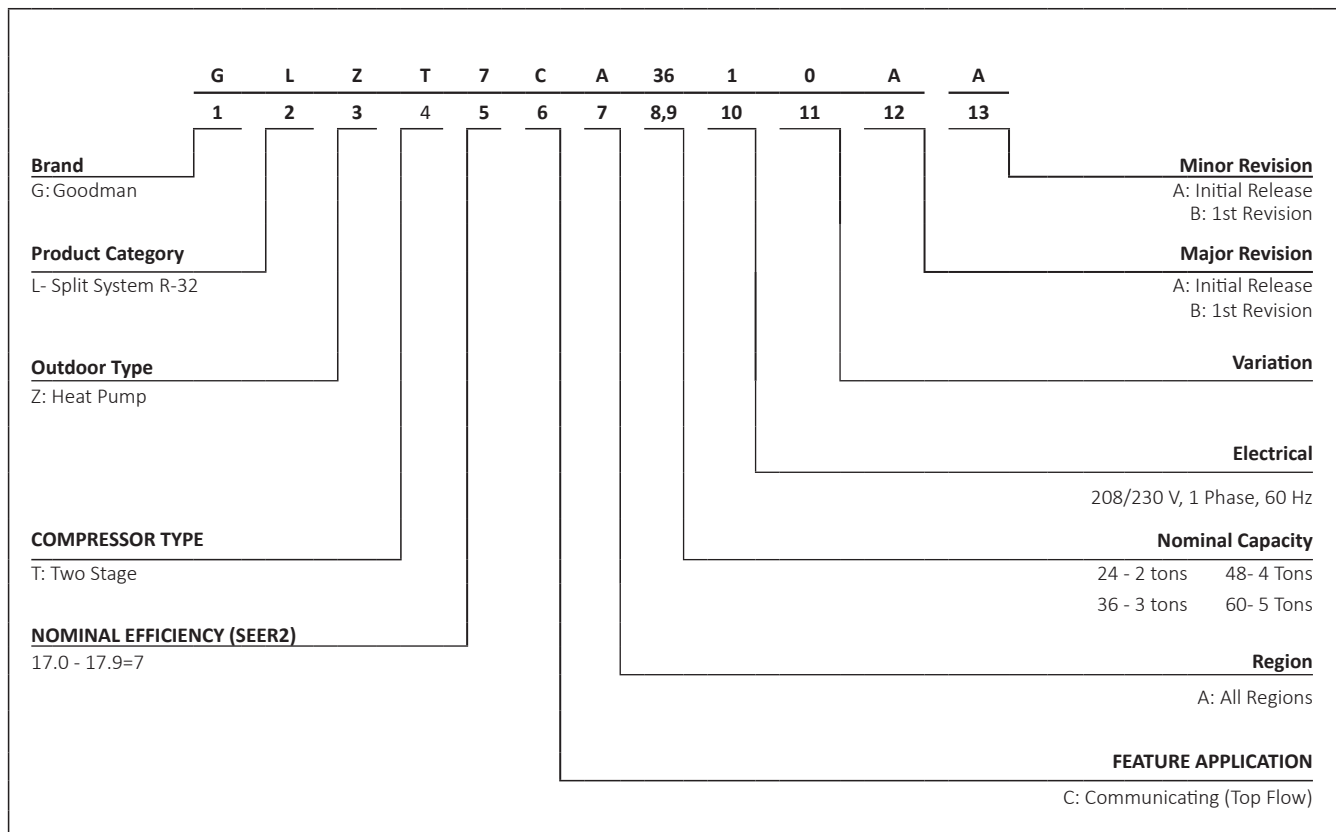

* Complete warranty details available from your local dealer or at www.goodmanmfg.com. To receive the Lifetime Compressor Limited Warranty (good for as long as you own your home), 10-Year Compressor Replacement Limited Warranty and 10-Year Parts Limited Warranty, online registration must be completed within 60 days of installation. Online registration and some of the additional requirements are not required in Florida, California, or Québec. The duration of warranty coverage in Texas and Florida differs in some cases. Other limitations and exclusions apply; refer to complete warranty details for a full list of limitations and exclusions.

NOMENCLATURE



	GLZT7CA 2410A*	GLZT7CA 610A*	GLZT7CA 4810A*	GLZT7CA 6010A*
NOMINAL CAPACITIES				
Cooling (BTU/h)	24,000	36,000	48,000	60,000
Heating (BTU/h)	24,000	36,000	48,000	60,000
Decibels	72	71	75	75
COMPRESSOR				
RLA	9.9	14.6	23.3	27.1
LRA	67.5	91.0	128.4	178.0
Stage	Two	Two	Two	Two
Type	Scroll	Scroll	Scroll	Scroll
CONDENSER FAN MOTOR				
Motor Type	ECM	ECM	ECM	ECM
Horsepower	1/3	1/3	1/3	1/3
FLA	2.80	2.80	2.80	2.80
REFRIGERATION SYSTEM				
Refrigerant Line Size ¹				
Liquid Line Size ("O.D.)	3/8"	3/8"	3/8"	3/8"
Suction Line Size ("O.D.)	3/4"	7/8"	1 1/8"	1 1/8"
Refrigerant Connection Size				
Liquid Valve Size ("O.D.)	3/8"	3/8"	3/8"	3/8"
Suction Valve Size ("O.D.)	3/4"	7/8"	1 1/8"	1 1/8"
Valve Connection Type	Sweat	Sweat	Sweat	Sweat
Refrigerant Charge (oz.)	103	129	229	198
ELECTRICAL DATA				
Voltage-Phase-Hz	208/230-1-60	208/230-1-60	208/230-1-60	208/230-1-60
Minimum Circuit Ampacity ²	15.0	20.8	31.6	36.4
Max. Overcurrent Protection ³	20	35	50	60
Min / Max Volts	197/253	197/253	197/253	197/253
Electrical Conduit Size	1/2" or 3/4"	1/2" or 3/4"	1/2" or 3/4"	1/2" or 3/4"
UNIT WEIGHTS				
Equipment Weight	219	262	308	306
Shipping Weight	235	277	323	321
ENERGY STAR® CERTIFIED [^]				
				

¹ Tested and rated in accordance with AHRI Standard 210/240

² Wire size should be determined in accordance with National Electrical Codes; extensive wire runs will require larger wire sizes

³ Must use time-delay fuses or HACR-type circuit breakers of the same size as noted.

NOTES

- Always check the rating plate for electrical data on the unit being installed.
- Installer will need to supply 3/8" to 1 1/8" adapters for suction line connections.
- Unit is charged with refrigerant for 15' of 3/8" liquid line. System charge must be adjusted per Installation Instructions Final Charge Procedure.
- Installation of these units requires the specified TXV Kit to be installed on the indoor coil. THE SPECIFIED TXV IS DETERMINED BY THE OUTDOOR UNIT, NOT THE INDOOR COIL.

[^] ENERGY STAR NOTES

- Products that are recognized as the Most Efficient of **ENERGY STAR®** in 2024 prevent greenhouse gas emissions by meeting rigorous energy efficiency performance levels set by the U.S. Environmental Protection Agency.
- Proper sizing and installation of equipment is critical to achieving optimal performance. Split system air conditioners and heat pumps must be matched with appropriate coil components to meet **ENERGY STAR®** criteria. Ask your contractor for details or visit www.energystar.gov.
- The www.energystar.gov website provides up-to-date system combinations certified to meet **ENERGY STAR®** requirements

EXPANDING COOLING DATA — GLZT7CA2410A*+DMVT30BP1300A*

IDB	AIRFLOW	OUTDOOR AMBIENT TEMPERATURE																																																	
		65°F						75°F						85°F						95°F						105°F						115°F																			
		59	63	67	71	75	79	59	63	67	71	75	79	59	63	67	71	75	79	59	63	67	71	75	79	59	63	67	71	75	79	59	63	67	71	75	79														
	Capacity	24471	24816	25545	-	24252	24597	25326	-	23615	23959	24689	-	22518	22862	23592	-	21177	21522	22251	-	19953	20298	21027	-	Capacity	24738	25083	25812	-	24519	24864	25594	-	23882	24227	24956	-	22785	23130	23859	-	21444	21789	22518	-	20220	20565	21295	-	
	S/T	0.61	0.54	0.40	-	0.62	0.54	0.41	-	0.64	0.57	0.43	-	1.00	0.59	0.45	-	1.00	0.61	0.47	-	1.00	0.66	0.53	-	S/T	0.66	0.58	0.45	-	0.66	0.59	0.45	-	1.00	0.63	0.50	-	1.00	0.63	0.50	-	1.00	0.65	0.52	-	1.00	0.71	0.57	-	
700	Evap dT	20	18	14	-	20	18	14	-	20	18	15	-	20	18	14	-	19	17	13	-	19	17	13	-	Evap dT	19	17	14	-	19	17	13	-	19	17	14	-	19	17	13	-	19	17	13	-	20	18	14	-	
	Pr Suc	126	128	131	-	134	136	139	-	141	142	145	-	146	148	151	-	152	154	157	-	159	160	164	-	Pr Suc	128	129	133	-	136	137	140	-	142	144	147	-	148	149	153	-	153	155	158	-	160	162	165	-	
780	Pr Dis	236	237	239	-	273	275	276	-	312	314	315	-	354	355	357	-	400	401	402	-	448	449	451	-	Pr Dis	238	239	241	-	275	276	278	-	314	315	317	-	356	357	359	-	401	402	404	-	450	451	452	-	
	Amps	5.2	5.2	5.2	-	5.9	5.9	5.9	-	6.7	6.7	6.7	-	7.6	7.6	7.6	-	8.6	8.6	8.6	-	9.7	9.7	9.7	-	Amps	5.2	5.2	5.2	-	5.9	5.9	5.9	-	6.8	6.7	6.7	-	7.6	7.6	7.6	-	8.6	8.6	8.6	-	9.8	9.7	9.7	-	
900	kW	1.38	1.38	1.37	-	1.55	1.54	1.54	-	1.73	1.73	1.73	-	1.94	1.93	1.93	-	2.16	2.16	2.15	-	2.42	2.42	2.42	-	kW	1.39	1.38	1.38	-	1.55	1.55	1.55	-	1.74	1.74	1.73	-	1.94	1.94	1.94	-	2.16	2.16	2.16	-	2.43	2.43	2.42	-	
	Capacity	25223	25568	26297	-	25004	25349	26078	-	24367	24711	25441	-	23270	23614	24344	-	21929	22274	23003	-	20705	21050	21779	-	Capacity	25223	25568	26297	-	25004	25349	26078	-	24367	24711	25441	-	23270	23614	24344	-	21929	22274	23003	-	20705	21050	21779	-	
	S/T	0.70	0.62	0.49	-	0.70	0.63	0.49	-	1.00	0.65	0.52	-	1.00	0.67	0.54	-	1.00	0.69	0.56	-	1.00	1.00	0.61	-	S/T	0.70	0.62	0.49	-	0.70	0.63	0.49	-	1.00	0.65	0.52	-	1.00	0.67	0.54	-	1.00	0.69	0.56	-	1.00	1.00	0.61	-	
70	Evap dT	18	16	12	-	18	16	12	-	18	16	13	-	18	16	12	-	17	16	12	-	17	17	13	-	Evap dT	18	16	12	-	18	16	12	-	18	16	13	-	18	16	12	-	17	16	12	-	17	17	13	-	
	Pr Suc	130	132	135	-	138	140	143	-	145	146	150	-	150	152	155	-	156	158	161	-	163	165	168	-	Pr Suc	130	132	135	-	138	140	143	-	145	146	150	-	150	152	155	-	156	158	161	-	163	165	168	-	
900	Pr Dis	240	241	243	-	278	279	280	-	317	318	319	-	359	360	361	-	404	405	406	-	452	453	455	-	Pr Dis	240	241	243	-	278	279	280	-	317	318	319	-	359	360	361	-	404	405	406	-	452	453	455	-	
	Amps	5.3	5.3	5.2	-	6.0	6.0	6.0	-	6.8	6.8	6.8	-	7.7	7.7	7.6	-	8.6	8.6	8.6	-	9.8	9.8	9.8	-	Amps	5.3	5.3	5.2	-	6.0	6.0	6.0	-	6.8	6.8	6.8	-	7.7	7.7	7.6	-	8.6	8.6	8.6	-	9.8	9.8	9.8	-	
75	kW	1.39	1.39	1.39	-	1.56	1.56	1.56	-	1.75	1.75	1.74	-	1.95	1.95	1.94	-	2.17	2.17	2.17	-	2.44	2.44	2.43	-	kW	1.39	1.39	1.39	-	1.56	1.56	1.56	-	1.75	1.75	1.74	-	1.95	1.95	1.94	-	2.17	2.17	2.17	-	2.44	2.44	2.43	-	
	Capacity	24485	24830	25559	26673	24266	24611	25341	26455	23629	23974	24703	25817	22532	22877	23606	24720	21191	21536	22265	23380	19967	20312	21042	22156	Capacity	24752	25097	25827	26941	24534	24879	25608	26722	23896	24241	24970	26085	22799	23144	23873	24988	21458	21803	22533	23647	20235	20579	21309	22423	
	S/T	0.79	0.71	0.58	0.44	1.00	0.72	0.58	0.44	1.00	0.74	0.61	0.47	1.00	0.76	0.63	0.49	1.00	0.74	0.65	0.51	1.00	1.00	0.70	0.56	S/T	0.82	0.75	0.61	0.47	1.00	0.75	0.62	0.48	1.00	0.78	0.65	0.50	1.00	0.80	0.66	0.52	1.00	0.80	0.66	0.52	1.00	1.00	0.74	0.60	
700	Evap dT	23	21	18	14	23	21	18	14	23	21	18	14	23	21	18	14	23	21	17	14	24	22	18	15	Evap dT	23	21	18	14	23	21	18	14	23	21	18	14	23	21	18	14	23	21	17	14	24	22	18	15	
	Pr Suc	128	129	133	138	136	137	140	146	142	144	147	152	148	150	153	158	164	154	155	158	164	161	162	165	171	Pr Suc	128	129	133	138	136	137	140	146	142	144	147	152	148	150	153	158	164	154	155	158	164	161	162	165
780	Pr Dis	238	239	241	245	275	276	278	282	314	315	317	321	356	357	359	363	402	403	404	408	450	451	453	457	Pr Dis	238	239	241	245	275	276	278	282	314	315	317	321	356	357	359	363	402	403	404	408	450	451	453	457	
	Amps	5.2	5.2	5.2	5.3	5.9	5.9	5.9	6.0	6.7	6.7	6.7	6.8	7.6	7.6	7.6	7.7	8.6	8.6	8.6	8.6	9.7	9.7	9.7	9.8	Amps	5.2	5.2	5.2	5.3	5.9	5.9	5.9	6.0	6.7	6.7	6.7	6.8	7.6	7.6	7.6	7.7	8.6	8.6	8.6	8.6	9.7	9.7	9.7	9.8	
900	kW	1.38	1.38	1.38	1.39	1.55	1.55	1.55	1.56	1.74	1.74	1.73	1.75	1.94	1.94	1.93	1.95	2.16	2.16	2.16	2.17	2.43	2.43	2.42	2.44	kW	1.38	1.38	1.38	1.39	1.55	1.55	1.55	1.56	1.74	1.74	1.73	1.75	1.94	1.94	1.93	1.95	2.16	2.16	2.16	2.17	2.43	2.43	2.42	2.44	
	Capacity	25237	25582	26311	27425	25018	25363	26093	27207	24381	24726	25455	26569	23284	23629	24358	25472	21943	22288	23017	24132	20719	21064	21794	22908	Capacity	25237	25582	26311	27425	25018	25363	26093	27207	24381	24726	25455	26569	23284	23629	24358	25472	21943	22288	23017	24132	20719	21064	21794	22908	
	S/T	0.82	0.75	0.61	0.47	1.00	0.75	0.62	0.48	1.00	0.78	0.65	0.50	1.00	0.80	0.66	0.52	1.00	0.80	0.66	0.52	1.00	1.00	0.74	0.60	S/T	0.82	0.75	0.61	0.47	1.00	0.75	0.62	0.48	1.00	0.78	0.65	0.50	1.00	0.80	0.66	0.52	1.00	0.80	0.66	0.52	1.00	1.00	0.74	0.60	
700	Evap dT	22	20	16	13	22	20	16	13	22	20	17	13	22	20	16	13	22	20	16	13	23	21	17	14	Evap dT	22	20	16	13	22	20	16	13	22	20	17	13	22	20	16	13	22	20	16	13	23	21	17	14	
	Pr Suc	130	132	135	141	138	140	143	148	145	146	150	155	151	152	155	161	166	156	158	161	166	163	165	173	Pr Suc	130	132	135	141	138	140	143	148	145	146	150	155	151	152	155	161	166	156	158	161	166	163	165	173	
900	Pr Dis	241	242	243	247	278	279	280	285	317	318	319	324	359	360	361	366	404	405	407	411	452	453	455	459	Pr Dis	241	242	243	247	278	279	280	285	317	318	319	324	359	360	361	366	404	405	407	411	452	453	455	459	
	Amps	5.3	5.2	5.2	5.3	6.0	6.0	6.0	6.0	6.8	6.8	6.8	6.8	7.7	7.7	7.6	7.7	8.6	8.6	8.6	8.6	9.8	9.8	9.8	9.8	Amps	5.3	5.2	5.2	5.3	6.0	6.0	6.0	6.0	6.8	6.8	6.8	6.8	7.7	7.7	7.6	7.7	8.6	8.6	8.6	8.6	9.8	9.8	9.8	9.8	
75	kW	1.39	1.39	1.39	1.40	1.56	1.56	1.56	1.57	1.75	1.74	1.74	1.75	1.95	1.95	1.94	1.96	2.17	2.17	2.17	2.18	2.44	2.43	2.43	2.44	kW	1.39	1.39	1.39	1.40	1.56	1.56	1.56	1.57	1.75	1.74	1.74	1.75	1.95	1.95	1.94	1.96	2.17	2.17	2.17	2.18	2.44	2.43	2.43	2.44	
	Capacity	24485	24830	25559	26673	24266	24611	25341	26455	23629	23974	24703	25817	22532	22877	23606	24720	21191	21536	22265	23380	19967	20312	21042	22156	Capacity	2475																								

EXPANDING COOLING DATA — GLZT7CA2410A*+DMVT30BP1300A* (CONT.)

IDB	AIRFLOW	OUTDOOR AMBIENT TEMPERATURE																							
		65°F				75°F				85°F				95°F				105°F				115°F			
		59	63	67	71	59	63	67	71	59	63	67	71	59	63	67	71	59	63	67	71	59	63	67	71
700	Capacity	24611	24956	25686	26800	24393	24738	25467	26581	23755	24100	24830	25944	22658	23003	23733	24847	21318	21663	22392	23506	20094	20439	21168	22282
	S/T	1.00	0.79	0.65	0.51	1.00	0.79	0.66	0.52	1.00	0.82	0.68	0.54	1.00	1.00	0.70	0.56	1.00	1.00	0.73	0.58	1.00	1.00	0.78	0.64
	Evap dT	28	26	23	19	28	26	23	19	28	26	23	19	28	26	22	19	28	26	22	19	29	27	23	20
	Pr Suc	127	128	132	137	135	136	139	145	141	143	146	151	147	149	152	157	153	154	157	163	160	161	164	170
	Pr Dis	237	238	240	244	274	275	277	281	313	314	316	320	355	356	358	362	400	401	403	407	449	450	451	455
	Amps	5.2	5.2	5.2	5.2	5.9	5.9	5.9	6.0	6.7	6.7	6.7	6.8	7.6	7.6	7.6	7.6	8.6	8.6	8.6	8.6	9.7	9.7	9.7	9.8
kW	1.38	1.38	1.37	1.39	1.55	1.54	1.54	1.55	1.73	1.73	1.73	1.74	1.93	1.93	1.93	1.94	2.16	2.16	2.16	2.17	2.42	2.42	2.42	2.43	
80	Capacity	24879	25224	25953	27067	24660	25005	25734	26849	24023	24367	25097	26211	22926	23270	24000	25114	21585	21930	22659	23773	20361	20706	21435	22549
	S/T	1.00	0.83	0.70	0.56	1.00	0.84	0.71	0.57	1.00	0.86	0.73	0.59	1.00	1.00	0.75	0.61	1.00	1.00	0.77	0.63	1.00	1.00	0.82	0.68
	Evap dT	27	25	22	18	27	25	22	18	27	25	22	18	27	25	22	18	27	25	21	18	28	26	23	19
	Pr Suc	128	130	133	139	136	138	141	146	143	144	148	153	149	150	153	159	154	156	159	164	161	163	166	171
	Pr Dis	239	240	241	245	276	277	278	283	315	316	317	322	357	358	359	364	402	403	405	409	450	451	453	457
	Amps	5.2	5.2	5.2	5.3	5.9	5.9	5.9	6.0	6.8	6.7	6.7	6.8	7.6	7.6	7.6	7.7	8.6	8.6	8.6	8.6	9.8	9.7	9.7	9.8
kW	1.39	1.39	1.38	1.39	1.55	1.55	1.55	1.56	1.74	1.74	1.73	1.75	1.94	1.94	1.94	1.95	2.17	2.17	2.17	2.17	2.43	2.43	2.43	2.44	
900	Capacity	25363	25708	26438	27552	25145	25490	26219	27333	24507	24852	25582	26696	23410	23755	24485	25599	22070	22414	23144	24258	20846	21191	21920	23034
	S/T	1.00	0.87	0.74	0.60	1.00	0.88	0.74	0.60	1.00	1.00	0.77	0.63	1.00	1.00	0.79	0.65	1.00	1.00	0.81	0.67	1.00	1.00	1.00	0.72
	Evap dT	26	24	21	17	26	24	20	17	26	24	21	17	26	24	20	17	25	24	20	17	27	25	21	18
	Pr Suc	131	133	136	141	139	140	143	149	145	147	150	156	151	153	156	161	157	158	161	167	164	165	168	174
	Pr Dis	241	242	244	248	278	279	281	285	317	318	320	324	359	360	362	366	404	405	407	411	453	454	455	460
	Amps	5.3	5.3	5.2	5.3	6.0	6.0	6.0	6.0	6.8	6.8	6.8	6.8	7.7	7.7	7.6	7.7	8.6	8.6	8.6	8.6	9.8	9.8	9.8	9.8
kW	1.39	1.39	1.39	1.40	1.56	1.56	1.56	1.57	1.75	1.75	1.74	1.76	1.95	1.95	1.95	1.94	2.17	2.17	2.17	2.18	2.44	2.44	2.44	2.44	

700	Capacity	25023	25368	26097	27211	24804	25149	25879	26993	24167	24512	25241	26355	23070	23415	24144	25258	21729	22074	22803	23918	20505	20850	21579	22694
	S/T	1.00	0.89	0.75	0.61	1.00	1.00	0.76	0.62	1.00	1.00	0.78	0.64	1.00	1.00	0.80	0.66	1.00	1.00	1.00	0.68	1.00	1.00	1.00	0.74
	Evap dT	31	30	26	23	31	30	26	23	32	30	26	23	31	30	26	23	31	29	26	22	32	30	27	23
	Pr Suc	129	130	134	139	136	138	141	147	143	145	148	153	149	150	154	159	154	156	159	165	161	163	166	172
	Pr Dis	238	239	241	245	275	276	278	282	314	315	317	321	356	357	359	363	401	403	404	408	450	451	452	457
	Amps	5.2	5.2	5.2	5.2	5.9	5.9	5.9	6.0	6.7	6.7	6.7	6.8	7.6	7.6	7.6	7.6	8.6	8.6	8.6	8.6	9.7	9.7	9.7	9.8
kW	1.38	1.38	1.38	1.39	1.55	1.55	1.54	1.56	1.73	1.73	1.73	1.74	1.94	1.93	1.93	1.94	2.16	2.16	2.16	2.17	2.42	2.42	2.42	2.43	
780	Capacity	25290	25635	26364	27479	25072	25416	26146	27260	24434	24779	25508	26622	23337	23682	24411	25525	21996	22341	23071	24185	20772	21117	21847	22961
	S/T	1.00	0.93	0.80	0.66	1.00	1.00	0.81	0.67	1.00	1.00	0.83	0.69	1.00	1.00	0.85	0.71	1.00	1.00	1.00	0.73	1.00	1.00	1.00	0.78
	Evap dT	31	29	25	22	31	29	25	22	31	29	25	22	31	29	25	22	30	28	25	21	31	30	26	23
	Pr Suc	130	132	135	140	138	140	143	148	145	146	149	155	150	152	155	161	156	158	161	166	163	165	168	173
	Pr Dis	240	241	242	246	277	278	280	284	316	317	319	323	358	359	361	365	403	404	406	410	451	452	454	458
	Amps	5.2	5.2	5.2	5.3	6.0	6.0	6.0	6.0	6.8	6.8	6.7	6.8	7.6	7.6	7.6	7.7	8.6	8.6	8.6	8.7	9.8	9.8	9.7	9.8
kW	1.39	1.39	1.38	1.40	1.56	1.55	1.55	1.56	1.74	1.74	1.74	1.75	1.94	1.94	1.94	1.95	2.17	2.17	2.16	2.18	2.43	2.43	2.43	2.44	
900	Capacity	25775	26120	26849	27963	25556	25901	26631	27745	24919	25264	25993	27107	23822	24167	24896	26010	22481	22826	23555	24669	21257	21602	22331	23446
	S/T	1.00	0.97	0.84	0.70	1.00	1.00	0.84	0.70	1.00	1.00	0.87	0.73	1.00	1.00	0.89	0.75	1.00	1.00	1.00	0.77	1.00	1.00	1.00	0.82
	Evap dT	29	28	24	21	29	28	24	21	30	28	24	21	29	28	24	21	29	27	24	20	30	28	25	21
	Pr Suc	133	134	138	143	141	142	145	151	147	149	152	157	153	155	158	163	159	160	163	169	166	167	170	176
	Pr Dis	242	243	245	249	279	280	282	286	318	319	321	325	360	361	363	367	406	407	408	412	454	455	457	461
	Amps	5.3	5.3	5.3	5.3	6.0	6.0	6.0	6.0	6.8	6.8	6.8	6.8	7.7	7.7	7.7	7.7	8.7	8.7	8.6	8.7	9.8	9.8	9.8	9.8
kW	1.40	1.40	1.39	1.41	1.56	1.56	1.56	1.57	1.75	1.75	1.75	1.76	1.95	1.95	1.95	1.96	2.18	2.17	2.17	2.18	2.44	2.44	2.44	2.45	

IDB: Entering Indoor Dry Bulb Temperature
 High and low pressures are measured at the liquid and suction service valves.
 Shaded area reflects AHRI (TVA) conditions
 kW = Total system power
 Amps = outdoor unit amps (compressor + fan)

EXPANDING COOLING DATA — GLZT7CA2410A*+DMVT30BP1300A* (70%)

IDB	AIRFLOW	OUTDOOR AMBIENT TEMPERATURE																											
		65°F				75°F				85°F				95°F				105°F				115°F							
		59	63	67	71	59	63	67	71	59	63	67	71	59	63	67	71	59	63	67	71	59	63	67	71				
490	Capacity	17594	17842	18367	-	17437	17685	18210	-	16979	17227	17751	-	16190	16438	16963	-	15226	15474	15999	-	14346	14594	15119	-				
	S/T	0.63	0.55	0.41	-	0.63	0.56	0.42	-	1.00	0.58	0.44	-	1.00	0.60	0.46	-	1.00	0.62	0.49	-	1.00	0.62	0.49	-				
	Evap dT	19	17	14	-	19	17	14	-	19	17	14	-	19	17	14	-	19	17	14	-	19	17	14	-				
	Pr Suc	130	131	135	-	138	139	143	-	145	146	150	-	150	152	155	-	156	158	161	-	163	165	168	-				
	Pr Dis	130	227	228	-	261	262	264	-	299	300	301	-	339	340	341	-	382	383	385	-	428	429	431	-				
546	Amps	3.3	3.3	3.3	-	3.7	3.7	3.7	-	4.2	4.2	4.2	-	4.8	4.8	4.8	-	5.4	5.4	5.4	-	6.1	6.1	6.1	-	6.1	6.1	6.1	-
	kW	0.87	0.87	0.86	-	0.97	0.97	0.97	-	1.09	1.09	1.09	-	1.22	1.22	1.22	-	1.36	1.36	1.35	-	1.52	1.52	1.52	-				
	Capacity	17787	18035	18559	-	17629	17877	18402	-	17171	17419	17943	-	16382	16630	17155	-	15418	15666	16191	-	14538	14786	15311	-				
	S/T	0.68	0.60	0.46	-	0.68	0.60	0.47	-	1.00	0.63	0.49	-	1.00	0.65	0.51	-	1.00	0.67	0.53	-	1.00	0.67	0.53	-				
	Evap dT	18	16	13	-	18	16	13	-	18	17	13	-	18	16	13	-	18	16	13	-	19	17	14	-				
630	Pr Suc	131	133	136	-	139	141	144	-	146	148	151	-	152	154	157	-	158	159	163	-	165	167	170	-				
	Pr Dis	227	228	230	-	263	264	266	-	300	301	303	-	340	341	343	-	384	385	386	-	430	431	432	-				
	Amps	3.3	3.3	3.3	-	3.7	3.7	3.7	-	4.2	4.2	4.2	-	4.8	4.8	4.8	-	5.4	5.4	5.4	-	6.1	6.1	6.1	-				
	kW	0.87	0.87	0.87	-	0.98	0.98	0.97	-	1.09	1.09	1.09	-	1.22	1.22	1.22	-	1.36	1.36	1.36	-	1.53	1.53	1.52	-				
	Capacity	18135	18383	18908	-	17978	18226	18750	-	17520	17767	18292	-	16731	16979	17503	-	15767	16015	16539	-	14887	15135	15659	-				
70	S/T	0.71	0.64	0.50	-	0.72	0.64	0.51	-	1.00	0.67	0.53	-	1.00	0.69	0.55	-	1.00	0.71	0.57	-	1.00	0.71	0.57	-				
	Evap dT	17	15	12	-	17	15	12	-	17	15	12	-	17	15	12	-	17	15	12	-	18	16	13	-				
	Pr Suc	134	136	139	-	142	144	147	-	149	150	154	-	155	156	160	-	160	162	165	-	168	169	172	-				
	Pr Dis	230	231	232	-	265	266	268	-	303	304	305	-	343	344	345	-	386	387	389	-	432	433	435	-				
	Amps	3.3	3.3	3.3	-	3.8	3.8	3.8	-	4.3	4.3	4.3	-	4.8	4.8	4.8	-	5.4	5.4	5.4	-	6.2	6.2	6.1	-				
75	kW	0.88	0.88	0.87	-	0.98	0.98	0.98	-	1.10	1.10	1.10	-	1.23	1.22	1.22	-	1.37	1.37	1.36	-	1.53	1.53	1.53	-				
	Capacity	17605	17853	18377	19178	17448	17695	18220	19021	16989	17237	17762	18563	16200	16448	16973	17774	15236	15484	16009	16810	14356	14604	15129	15930				
	S/T	0.76	0.68	0.54	0.40	1.00	0.69	0.55	0.41	1.00	0.71	0.58	0.43	1.00	0.73	0.60	0.45	1.00	1.00	0.62	0.47	1.00	1.00	0.67	0.53				
	Evap dT	23	21	18	14	23	21	18	14	23	21	18	15	23	21	18	14	23	21	18	14	24	22	19	15				
	Pr Suc	130	132	135	140	138	139	143	148	145	146	150	155	151	152	155	161	156	158	161	167	163	165	168	174				
490	Pr Dis	226	227	229	233	262	263	264	268	299	300	301	305	339	340	342	346	382	383	385	389	429	430	431	435				
	Amps	3.3	3.3	3.3	3.3	3.7	3.7	3.7	3.7	4.2	4.2	4.2	4.2	4.8	4.8	4.8	4.8	5.4	5.4	5.4	5.4	6.1	6.1	6.1	6.1				
	kW	0.87	0.87	0.86	0.87	0.97	0.97	0.97	0.98	1.09	1.09	1.09	1.09	1.21	1.21	1.21	1.22	1.36	1.36	1.35	1.36	1.52	1.52	1.52	1.53				
	Capacity	17797	18045	18569	19370	17640	17888	18412	19213	17181	17429	17954	18755	16393	16641	17165	17966	15429	15677	16201	17002	14549	14797	15321	16122				
	S/T	0.81	0.73	0.59	0.45	1.00	0.74	0.60	0.45	1.00	0.76	0.62	0.48	1.00	0.78	0.64	0.50	1.00	1.00	0.67	0.52	1.00	1.00	0.72	0.57				
546	Evap dT	22	20	17	14	22	20	17	13	22	20	17	14	22	20	17	13	22	20	17	13	23	21	18	14				
	Pr Suc	131	133	136	142	139	141	144	150	146	148	151	157	152	154	157	163	158	159	163	168	165	167	170	175				
	Pr Dis	228	229	230	234	263	264	266	270	300	301	303	307	341	342	343	347	384	385	386	390	430	431	433	437				
	Amps	3.3	3.3	3.3	3.3	3.7	3.7	3.7	3.8	4.2	4.2	4.2	4.3	4.8	4.8	4.8	4.8	5.4	5.4	5.4	5.4	6.1	6.1	6.1	6.2				
	kW	0.87	0.87	0.87	0.88	0.98	0.97	0.97	0.98	1.09	1.09	1.09	1.10	1.22	1.22	1.22	1.22	1.36	1.36	1.36	1.37	1.53	1.53	1.52	1.53				
630	Capacity	18145	18393	18918	19719	17988	18236	18761	19562	17530	17778	18302	19103	16741	16989	17513	18315	15777	16025	16550	17351	14897	15145	15670	16471				
	S/T	1.00	0.77	0.63	0.49	1.00	0.77	0.64	0.49	1.00	0.80	0.66	0.52	1.00	1.00	0.68	0.54	1.00	1.00	0.70	0.56	1.00	1.00	0.76	0.61				
	Evap dT	21	19	16	12	21	19	16	12	21	19	16	13	21	19	16	12	21	19	16	12	22	20	17	13				
	Pr Suc	134	136	139	145	142	144	147	152	149	150	154	159	155	156	160	165	160	162	165	171	168	169	173	178				
	Pr Dis	230	231	232	236	266	266	268	272	303	304	305	309	343	344	345	349	386	387	389	393	432	433	435	439				
75	Amps	3.3	3.3	3.3	3.3	3.8	3.8	3.8	3.8	4.3	4.3	4.3	4.3	4.8	4.8	4.8	4.8	5.4	5.4	5.4	5.5	6.2	6.2	6.1	6.2				
	kW	0.88	0.88	0.87	0.88	0.98	0.98	0.98	0.99	1.10	1.10	1.10	1.10	1.22	1.22	1.22	1.23	1.37	1.37	1.36	1.37	1.53	1.53	1.53	1.54				

IDB	AIRFLOW	OUTDOOR AMBIENT TEMPERATURE																											
		65°F				75°F				85°F				95°F				105°F				115°F							
		59	63	67	71	59	63	67	71	59	63	67	71	59	63	67	71	59	63	67	71	59	63	67	71				
490	Capacity	17594	17842	18367	-	17437	17685	18210	-	16979	17227	17751	-	16190	16438	16963	-	15226	15474	15999	-	14346	14594	15119	-				
	S/T	0.63	0.55	0.41	-	0.63	0.56	0.42	-	1.00	0.58	0.44	-	1.00	0.60	0.46	-	1.00	0.62	0.49	-	1.00	0.62	0.49	-				
	Evap dT	19	17	14	-	19	17	14	-	19	17	14	-	19	17	14	-	19	17	14	-	19	17	14	-				
	Pr Suc	130	131	135	-	138	139	143	-	145	146	150	-	150	152	155	-	156	158	161	-	163	165	168	-				
	Pr Dis	130	227	228	-	261	262	264	-	299	300	301	-	339	340	341	-	382	383	385	-	428	429	431	-				
546	Amps	3.3	3.3	3.3	-	3.7	3.7	3.7	-	4.2	4.2	4.2	-	4.8	4.8	4.8	-	5.4	5.4	5.4	-	6.1	6.1	6.1	-	6.1	6.1	6.1	-
	kW	0.87	0.87	0.86	-	0.97	0.97	0.97	-	1.09	1.09	1.09	-	1.22	1.22	1.22	-	1.36	1.36	1.35	-	1.52	1.52	1.52	-				
	Capacity	17787	18035	18559	-	17629	17877	18402	-	17171	17419	17943	-	16382	16630	17155	-	15418	15666	16191	-	14538	14786	15311	-				
	S/T	0.68	0.60	0.46	-	0.68	0.60	0.47	-	1.00	0.63	0.49	-	1.00	0.65	0.51	-	1.00	0.67	0.53	-	1.00	0.67	0.53	-				
	Evap dT	18	16	13	-	18	16	13	-	18	17	13	-	18	16	13	-	18	16	13	-	19	17	14	-				
630	Pr Suc	131	133	136	-	139	141	144	-	146	148	151	-	152	154	157	-	158	159	163	-	165	167	170	-				
	Pr Dis	227	228	230	-	263	264	266	-	300	301	303	-	340	341	343	-	384	385	386	-	430	431	432</					

EXPANDING COOLING DATA — GLZT7CA2410A*+DMVT30BP1300A* (70%) (CONT.)

IDB	AIRFLOW	OUTDOOR AMBIENT TEMPERATURE																							
		65°F				75°F				85°F				95°F				105°F				115°F			
		59	63	67	71	59	63	67	71	59	63	67	71	59	63	67	71	59	63	67	71	59	63	67	71
80	Capacity	17696	17944	18468	19269	17538	17786	18311	19112	17080	17328	17852	18654	16291	16539	17064	17865	15327	15575	16100	16901	14447	14695	15220	16021
	S/T	1.00	0.81	0.67	0.53	1.00	0.82	0.68	0.53	1.00	0.70	0.56	0.42	1.00	0.50	0.36	0.22	1.00	0.30	0.16	0.02	1.00	0.10	0.00	0.00
	Evap dT	27	25	22	18	27	25	22	18	27	25	22	19	27	25	22	18	27	25	21	18	27	25	22	19
	Pr Suc	130	132	135	141	138	140	143	149	145	147	150	156	151	153	156	162	157	158	162	167	164	166	169	174
	Pr Dis	226	227	229	233	262	263	265	269	299	300	302	306	339	340	342	346	383	384	385	389	429	430	432	435
	Amps	3.3	3.3	3.3	3.3	3.7	3.7	3.7	3.7	4.2	4.2	4.2	4.3	4.8	4.8	4.8	4.8	5.4	5.4	5.4	5.4	6.1	6.1	6.1	6.1
kW	0.87	0.87	0.86	0.87	0.97	0.97	0.97	0.98	1.09	1.09	1.09	1.09	1.22	1.21	1.21	1.22	1.36	1.36	1.35	1.36	1.52	1.52	1.52	1.53	
Capacity	17888	18136	18660	19461	17731	17979	18503	19304	17272	17520	18045	18846	16483	16731	17256	18057	15520	15768	16292	17093	14640	14888	15412	16213	
S/T	1.00	0.86	0.72	0.57	1.00	0.86	0.73	0.58	1.00	0.75	0.61	0.47	1.00	0.40	0.26	0.12	1.00	0.20	0.06	0.00	1.00	0.00	0.00	0.00	
Evap dT	26	24	21	17	26	24	21	17	26	24	21	18	26	24	21	17	26	24	21	17	27	25	22	18	
Pr Suc	132	134	137	142	140	142	145	150	147	148	152	157	153	154	158	163	158	160	163	169	166	167	170	176	
Pr Dis	228	229	231	235	264	265	266	270	301	302	303	307	341	342	344	348	384	385	387	391	431	432	433	437	
Amps	3.3	3.3	3.3	3.3	3.7	3.7	3.7	3.8	4.2	4.2	4.2	4.3	4.8	4.8	4.8	4.8	5.4	5.4	5.4	5.4	6.1	6.1	6.1	6.2	
kW	0.87	0.87	0.87	0.88	0.98	0.98	0.97	0.98	1.09	1.09	1.09	1.10	1.22	1.22	1.22	1.23	1.36	1.36	1.36	1.37	1.53	1.53	1.53	1.53	
Capacity	18236	18484	19009	19810	18079	18327	18852	19653	17621	17869	18393	19194	16832	17080	17604	18405	15868	16116	16640	17442	14988	15236	15760	16562	
S/T	1.00	0.90	0.76	0.61	1.00	0.90	0.76	0.62	1.00	0.79	0.64	0.50	1.00	0.40	0.26	0.12	1.00	0.20	0.06	0.00	1.00	0.00	0.00	0.00	
Evap dT	25	23	20	16	25	23	20	16	25	23	20	17	25	23	20	16	25	23	20	16	26	24	21	17	
Pr Suc	135	136	140	145	143	144	147	153	149	151	154	160	155	157	160	166	161	163	166	171	168	170	173	179	
Pr Dis	230	231	233	237	266	267	268	272	303	304	306	310	343	344	346	350	387	388	389	393	433	434	435	439	
Amps	3.3	3.3	3.3	3.3	3.8	3.8	3.8	3.8	4.3	4.3	4.3	4.3	4.8	4.8	4.8	4.8	5.4	5.4	5.4	5.4	6.2	6.2	6.2	6.2	
kW	0.88	0.88	0.87	0.88	0.98	0.98	0.98	0.99	1.10	1.10	1.10	1.10	1.23	1.22	1.22	1.23	1.37	1.37	1.36	1.37	1.53	1.53	1.53	1.54	

85	Capacity	17991	18239	18764	19565	17834	18082	18607	19408	17376	17624	18148	18949	16587	16835	17360	18161	15623	15871	16396	17197	14743	14991	15516	16317
	S/T	1.00	0.91	0.77	0.63	1.00	0.80	0.67	0.53	1.00	0.60	0.47	0.33	1.00	0.30	0.16	0.02	1.00	0.10	0.00	0.00	1.00	0.00	0.00	0.00
	Evap dT	30	29	25	22	30	29	25	22	31	29	25	22	30	29	25	22	30	28	25	22	31	29	26	23
	Pr Suc	132	134	137	143	140	142	145	151	147	149	152	158	153	155	158	163	159	160	164	169	166	168	171	176
	Pr Dis	228	229	230	234	263	264	266	270	300	301	303	307	341	342	343	347	384	385	386	390	430	431	433	437
	Amps	3.3	3.3	3.3	3.3	3.7	3.7	3.7	3.8	4.2	4.2	4.2	4.3	4.8	4.8	4.8	4.8	5.4	5.4	5.4	5.4	6.1	6.1	6.1	6.1
kW	0.87	0.87	0.87	0.88	0.97	0.97	0.97	0.98	1.09	1.09	1.09	1.10	1.22	1.22	1.22	1.23	1.36	1.36	1.36	1.36	1.52	1.52	1.52	1.53	
Capacity	18184	18432	18956	19757	18026	18274	18799	19600	17568	17816	18340	19142	16779	17027	17552	18353	15815	16063	16588	17389	14935	15183	15708	16509	
S/T	1.00	0.82	0.68	0.54	1.00	0.80	0.67	0.53	1.00	0.60	0.47	0.33	1.00	0.30	0.16	0.02	1.00	0.10	0.00	0.00	1.00	0.00	0.00	0.00	
Evap dT	29	28	24	21	29	28	24	21	30	28	25	21	29	28	24	21	29	27	24	21	30	29	25	22	
Pr Suc	134	136	139	144	142	143	147	152	149	150	154	159	155	156	160	165	160	162	165	171	168	169	172	178	
Pr Dis	229	230	232	236	265	266	267	271	302	303	305	308	342	343	345	349	385	386	388	392	432	433	434	438	
Amps	3.3	3.3	3.3	3.3	3.7	3.7	3.7	3.8	4.3	4.3	4.3	4.3	4.8	4.8	4.8	4.8	5.4	5.4	5.4	5.4	6.1	6.1	6.1	6.2	
kW	0.87	0.87	0.87	0.88	0.98	0.98	0.98	0.98	1.10	1.09	1.09	1.10	1.22	1.22	1.22	1.23	1.36	1.36	1.36	1.37	1.53	1.53	1.53	1.53	
Capacity	18532	18780	19305	20106	18375	18623	19147	19948	17917	18164	18688	19490	17128	17376	17900	18701	16164	16412	16936	17737	15284	15532	16056	16857	
S/T	1.00	0.86	0.72	0.58	1.00	0.80	0.67	0.53	1.00	0.60	0.47	0.33	1.00	0.30	0.16	0.02	1.00	0.10	0.00	0.00	1.00	0.00	0.00	0.00	
Evap dT	28	27	23	20	28	27	23	20	29	27	24	20	28	27	23	20	28	26	23	20	29	27	24	21	
Pr Suc	137	138	142	147	145	146	149	155	151	153	156	162	157	159	162	168	163	165	168	173	170	172	175	181	
Pr Dis	231	232	234	238	267	268	270	273	304	305	307	311	344	345	347	351	388	389	390	394	434	435	436	440	
Amps	3.3	3.3	3.3	3.3	3.8	3.8	3.8	3.8	4.3	4.3	4.3	4.3	4.8	4.8	4.8	4.8	5.4	5.4	5.4	5.4	6.2	6.2	6.2	6.2	
kW	0.88	0.88	0.88	0.88	0.98	0.98	0.98	0.99	1.10	1.10	1.10	1.11	1.23	1.23	1.22	1.23	1.37	1.37	1.37	1.37	1.53	1.53	1.53	1.54	

IDB: Entering Indoor Dry Bulb Temperature
 High and low pressures are measured at the liquid and suction service valves.
 Shaded area reflects AHRI (TVA) conditions
 kW = Total system power
 Amps = outdoor unit amps (compressor + fan)

EXPANDING COOLING DATA — GLZT7CA3610A*+DMVT42CP1300A*

IDB	AIRFLOW	OUTDOOR AMBIENT TEMPERATURE																																			
		65°F						75°F						85°F						95°F						105°F						115°F					
		59	63	67	71	75	79	59	63	67	71	75	79	59	63	67	71	75	79	59	63	67	71	75	79	59	63	67	71	75	79	59	63	67	71	75	79
1050	Capacity	35430	35930	36988	-	35113	35613	36671	-	34189	34689	35746	-	32598	33098	34156	-	30654	31154	32212	-	28880	29380	30437	-	30654	31154	32212	-	28880	29380	30437	-				
	S/T	0.63	0.55	0.41	-	0.63	0.56	0.42	-	0.66	0.58	0.44	-	1.00	0.60	0.46	-	1.00	0.62	0.48	-	1.00	0.68	0.54	-	1.00	0.62	0.48	-	1.00	0.68	0.54	-				
	Evap dT	19	17	14	-	19	17	14	-	19	18	14	-	19	17	14	-	19	17	14	-	19	17	14	-	19	17	14	-	19	17	14	-				
	Pr Suc	124	125	128	-	131	133	136	-	138	139	142	-	143	145	148	-	149	150	153	-	156	157	160	-	149	150	153	-	156	157	160	-				
	Pr Dis	236	237	239	-	273	274	276	-	312	313	315	-	354	355	357	-	399	401	402	-	448	449	450	-	399	401	402	-	448	449	450	-				
Amps	6.5	6.5	6.5	-	7.4	7.4	7.4	-	8.5	8.5	8.5	-	9.6	9.6	9.6	-	10.9	10.9	10.9	-	12.4	12.4	12.4	-	10.9	10.9	10.9	-	12.4	12.4	12.4	-					
kW	1.84	1.84	1.84	-	2.06	2.05	2.05	-	2.30	2.29	2.29	-	2.56	2.55	2.55	-	2.85	2.85	2.85	-	3.19	3.19	3.18	-	2.85	2.85	2.85	-	3.19	3.19	3.18	-					
70	Capacity	35870	36370	37428	-	35553	36053	37111	-	34629	35129	36186	-	33038	33538	34596	-	31094	31594	32652	-	29319	29819	30877	-	31094	31594	32652	-	29319	29819	30877	-				
	S/T	0.68	0.61	0.47	-	0.69	0.61	0.47	-	0.72	0.64	0.50	-	1.00	0.66	0.52	-	1.00	0.68	0.54	-	1.00	0.73	0.59	-	1.00	0.68	0.54	-	1.00	0.73	0.59	-				
	Evap dT	18	16	13	-	18	16	13	-	18	17	13	-	18	16	13	-	18	16	13	-	19	17	14	-	18	16	13	-	19	17	14	-				
	Pr Suc	125	127	130	-	133	134	138	-	139	141	144	-	145	147	150	-	150	152	155	-	157	159	162	-	150	152	155	-	157	159	162	-				
	Pr Dis	238	239	241	-	275	276	278	-	314	315	317	-	356	357	359	-	401	402	404	-	450	451	452	-	356	357	359	-	401	402	404	-				
Amps	6.5	6.5	6.5	-	7.5	7.5	7.5	-	8.5	8.5	8.5	-	9.7	9.7	9.6	-	10.9	10.9	10.9	-	12.4	12.4	12.4	-	10.9	10.9	10.9	-	12.4	12.4	12.4	-					
kW	1.85	1.85	1.85	-	2.07	2.06	2.06	-	2.31	2.31	2.30	-	2.57	2.57	2.56	-	2.86	2.86	2.85	-	3.20	3.20	3.19	-	2.86	2.86	2.85	-	3.20	3.20	3.19	-					
1350	Capacity	36475	36975	38033	-	36158	36658	37716	-	35234	35734	36792	-	33643	34143	35201	-	31699	32199	33257	-	29925	30425	31482	-	31699	32199	33257	-	29925	30425	31482	-				
	S/T	0.72	0.64	0.50	-	0.73	0.65	0.51	-	0.75	0.67	0.54	-	1.00	0.69	0.56	-	1.00	0.72	0.58	-	1.00	0.77	0.63	-	1.00	0.72	0.58	-	1.00	0.77	0.63	-				
	Evap dT	17	15	12	-	17	15	12	-	17	16	12	-	17	15	12	-	17	15	12	-	18	16	13	-	17	15	12	-	18	16	13	-				
	Pr Suc	127	129	132	-	135	137	140	-	142	143	146	-	147	149	152	-	153	154	157	-	159	161	164	-	147	149	152	-	153	154	157	-				
	Pr Dis	240	241	243	-	277	278	280	-	316	317	319	-	358	359	361	-	403	404	406	-	452	453	454	-	358	359	361	-	403	404	406	-				
Amps	6.6	6.6	6.6	-	7.5	7.5	7.5	-	8.6	8.6	8.6	-	9.7	9.7	9.7	-	11.0	11.0	10.9	-	12.5	12.4	12.4	-	10.9	10.9	10.9	-	12.5	12.4	12.4	-					
kW	1.86	1.86	1.86	-	2.08	2.07	2.07	-	2.32	2.32	2.31	-	2.58	2.58	2.57	-	2.87	2.87	2.86	-	3.21	3.21	3.20	-	2.87	2.87	2.86	-	3.21	3.21	3.20	-					

1050	Capacity	35451	35951	37009	38624	35134	35634	36692	38307	34209	34709	35767	37383	32619	33119	34176	35792	30675	31175	32233	33848	28900	29400	30458	32073
	S/T	0.76	0.68	0.54	0.40	0.77	0.69	0.55	0.40	1.00	0.71	0.57	0.43	1.00	0.73	0.59	0.45	1.00	0.76	0.62	0.47	1.00	1.00	0.67	0.52
	Evap dT	23	21	18	15	23	21	18	14	23	22	18	15	23	21	18	14	23	21	18	14	24	22	19	15
	Pr Suc	124	125	128	134	131	133	136	141	138	139	142	148	143	145	148	153	149	150	153	159	156	157	160	166
	Pr Dis	236	237	239	243	273	274	276	280	312	313	315	319	354	355	357	361	400	401	402	407	448	449	451	455
Amps	6.5	6.5	6.5	6.5	7.4	7.4	7.4	7.5	8.5	8.5	8.5	8.5	9.6	9.6	9.6	9.7	10.9	10.9	10.9	10.9	12.4	12.3	12.3	12.4	
kW	1.84	1.84	1.83	1.85	2.05	2.05	2.05	2.07	2.30	2.29	2.29	2.31	2.56	2.55	2.55	2.57	2.85	2.84	2.84	2.86	3.19	3.19	3.18	3.20	
1190	Capacity	35891	36391	37448	39064	35574	36074	37132	38747	34649	35149	36207	37823	33059	33559	34616	36232	31115	31615	32672	34288	29340	29840	30898	32513
	S/T	0.82	0.74	0.60	0.45	0.82	0.74	0.61	0.46	1.00	0.77	0.63	0.48	1.00	0.79	0.65	0.50	1.00	0.81	0.67	0.53	1.00	1.00	0.73	0.58
	Evap dT	22	20	17	14	22	20	17	13	22	20	17	14	22	20	17	13	22	20	17	13	23	21	18	14
	Pr Suc	125	127	130	135	133	134	138	143	139	141	144	149	145	150	155	160	150	152	155	160	157	159	162	167
	Pr Dis	238	239	241	245	275	276	278	282	314	315	317	321	356	357	359	363	402	403	404	408	450	451	453	457
Amps	6.5	6.5	6.5	6.6	7.5	7.5	7.5	7.5	8.5	8.5	8.5	8.6	9.7	9.6	9.6	9.7	10.9	10.9	10.9	11.0	12.4	12.4	12.4	12.4	
kW	1.85	1.85	1.84	1.86	2.07	2.06	2.06	2.08	2.31	2.30	2.30	2.32	2.57	2.56	2.56	2.58	2.86	2.85	2.85	2.87	3.20	3.20	3.19	3.21	
1350	Capacity	36496	36996	38054	39669	36179	36679	37737	39352	35254	35755	36812	38428	33664	34164	35222	36837	31720	32220	33278	34893	29945	30445	31503	33119
	S/T	0.85	0.78	0.64	0.49	0.85	0.78	0.64	0.50	1.00	0.81	0.67	0.52	1.00	0.83	0.69	0.54	1.00	0.85	0.71	0.56	1.00	1.00	0.76	0.62
	Evap dT	21	19	16	13	21	19	16	13	21	20	16	13	21	19	16	12	21	19	16	12	22	20	17	13
	Pr Suc	128	129	132	137	135	137	140	145	142	143	146	152	147	149	152	157	153	154	157	163	159	161	164	169
	Pr Dis	240	241	243	247	277	278	280	284	316	317	319	323	358	359	361	365	404	405	406	410	452	453	455	459
Amps	6.6	6.6	6.6	6.6	7.5	7.5	7.5	7.6	8.6	8.6	8.6	8.6	9.7	9.7	9.7	9.7	11.0	11.0	10.9	11.0	12.4	12.4	12.4	12.5	
kW	1.86	1.86	1.85	1.87	2.08	2.07	2.07	2.09	2.32	2.31	2.31	2.33	2.58	2.57	2.57	2.59	2.87	2.86	2.86	2.88	3.21	3.21	3.20	3.22	

IDB: Entering Indoor Dry Bulb Temperature
 High and low pressures are measured at the liquid and suction service valves.
 Shaded area reflects ACCA (TVA) conditions
 kW = Total system power
 Amps = outdoor unit amps (compressor + fan)

EXPANDING COOLING DATA — GLZT7CA3610A*+DMVT42CP1300A* (CONT.)

IDB	AIRFLOW	OUTDOOR AMBIENT TEMPERATURE																							
		65°F				75°F				95°F				105°F				115°F							
		59	63	67	71	59	63	67	71	59	63	67	71	59	63	67	71	59	63	67	71				
1050	Capacity	35634	36134	37192	38807	35317	35817	36875	38491	34393	34893	35951	37566	32802	33302	34360	35975	30858	31358	32416	34031	29084	29584	30641	32257
	S/T	1.00	0.81	0.67	0.52	1.00	0.82	0.68	0.53	1.00	0.84	0.70	0.56	1.00	1.00	0.72	0.58	1.00	1.00	0.75	0.60	1.00	1.00	0.80	0.65
	Evap dT	27	25	22	18	27	25	22	18	27	25	22	19	27	25	22	18	27	25	22	18	28	26	23	19
	Pr Suc	124	126	129	134	132	133	136	142	138	140	143	148	144	145	149	154	149	151	154	159	156	158	161	166
	Pr Dis	237	238	239	243	274	275	277	281	313	314	316	320	355	356	358	362	400	401	403	407	448	449	451	455
Amps	6.5	6.5	6.5	6.6	7.4	7.4	7.4	7.5	8.5	8.5	8.5	8.5	9.6	9.6	9.6	9.7	10.9	10.9	10.9	10.9	12.4	12.4	12.4	12.4	
kW	1.84	1.84	1.84	1.85	2.06	2.05	2.05	2.07	2.30	2.29	2.29	2.31	2.56	2.55	2.55	2.57	2.85	2.85	2.85	2.86	3.19	3.19	3.19	3.20	
80	Capacity	36074	36574	37632	39247	35757	36257	37315	38930	34833	35333	36390	38006	33242	33742	34800	36415	31298	31798	32856	34471	29523	30024	31081	32697
	S/T	1.00	0.87	0.73	0.58	1.00	0.87	0.73	0.59	1.00	0.90	0.76	0.61	1.00	1.00	0.78	0.63	1.00	1.00	0.80	0.66	1.00	1.00	0.86	0.71
	Evap dT	26	24	21	18	27	25	22	18	27	25	22	18	27	25	22	18	27	25	21	18	28	26	23	19
	Pr Suc	126	127	131	136	133	135	138	143	140	142	145	150	146	147	150	155	151	153	156	161	158	159	163	168
	Pr Dis	239	240	241	245	276	277	278	283	315	316	317	322	357	358	359	364	402	403	405	409	450	451	453	457
Amps	6.5	6.5	6.5	6.6	7.5	7.5	7.5	7.5	8.5	8.5	8.5	8.6	9.7	9.7	9.6	9.7	10.9	10.9	10.9	11.0	12.4	12.4	12.4	12.5	
kW	1.85	1.85	1.85	1.86	2.07	2.06	2.06	2.08	2.31	2.30	2.30	2.32	2.57	2.57	2.56	2.58	2.86	2.86	2.86	2.87	3.20	3.20	3.20	3.21	
1350	Capacity	36679	37179	38237	39853	36362	36862	37920	39536	35438	35938	36996	38611	33847	34347	35405	37021	31903	32403	33461	35077	30129	30629	31686	33302
	S/T	1.00	0.90	0.76	0.62	1.00	0.91	0.77	0.62	1.00	0.94	0.80	0.65	1.00	1.00	0.82	0.67	1.00	1.00	0.84	0.69	1.00	1.00	0.89	0.75
	Evap dT	25	23	20	17	25	23	20	16	25	23	20	17	25	23	20	16	25	23	20	16	26	24	21	18
	Pr Suc	128	130	133	138	136	137	140	146	142	144	147	152	148	149	152	158	153	155	158	163	160	162	165	170
	Pr Dis	241	242	243	247	278	279	281	285	317	318	320	324	359	360	362	366	404	405	407	411	452	453	455	459
Amps	6.6	6.6	6.6	6.6	7.5	7.5	7.5	7.6	8.6	8.6	8.5	8.6	9.7	9.7	9.7	9.8	11.0	11.0	10.9	11.0	12.5	12.4	12.4	12.5	
kW	1.86	1.86	1.86	1.87	2.08	2.07	2.07	2.09	2.32	2.31	2.31	2.33	2.58	2.58	2.57	2.59	2.87	2.87	2.86	2.88	3.21	3.21	3.21	3.22	

1050	Capacity	36231	36731	37789	39404	35914	36414	37472	39087	34989	35489	36547	38163	33399	33899	34956	36572	31455	31955	33012	34628	29680	30180	31238	32853
	S/T	1.00	0.91	0.78	0.63	1.00	0.92	0.78	0.63	1.00	1.00	0.81	0.66	1.00	1.00	0.83	0.68	1.00	1.00	0.85	0.70	1.00	1.00	1.00	0.76
	Evap dT	31	29	25	22	30	29	25	22	31	29	26	22	30	29	25	22	30	28	25	22	31	30	26	23
	Pr Suc	126	128	131	136	134	135	138	143	140	142	145	150	146	147	150	156	151	153	156	161	158	160	163	168
	Pr Dis	238	239	240	245	275	276	278	282	314	315	317	321	356	357	359	363	401	402	404	408	450	451	452	456
Amps	6.5	6.5	6.5	6.6	7.5	7.4	7.4	7.5	8.5	8.5	8.5	8.5	9.6	9.6	9.6	9.7	10.9	10.9	10.9	10.9	12.4	12.4	12.4	12.4	
kW	1.84	1.84	1.84	1.86	2.06	2.06	2.05	2.07	2.30	2.30	2.29	2.31	2.56	2.56	2.56	2.57	2.85	2.85	2.85	2.86	3.19	3.19	3.19	3.20	
1190	Capacity	36671	37171	38228	39844	36354	36854	37911	39527	35429	35929	36987	38603	33839	34339	35396	37012	31895	32395	33452	35068	30120	30620	31678	33293
	S/T	1.00	0.97	0.83	0.69	1.00	1.00	0.84	0.69	1.00	1.00	0.86	0.72	1.00	1.00	0.88	0.74	1.00	1.00	0.91	0.76	1.00	1.00	1.00	0.81
	Evap dT	30	28	24	21	29	28	24	21	30	28	25	21	29	28	24	21	29	27	24	21	30	29	25	22
	Pr Suc	128	129	132	138	135	137	140	145	142	143	147	152	147	149	152	157	153	154	158	163	160	161	164	170
	Pr Dis	240	241	242	246	277	278	280	284	316	317	319	323	358	359	361	365	403	404	406	410	451	452	454	458
Amps	6.6	6.6	6.5	6.6	7.5	7.5	7.5	7.5	8.5	8.5	8.5	8.6	9.7	9.7	9.7	9.7	10.9	10.9	10.9	11.0	12.4	12.4	12.4	12.5	
kW	1.86	1.85	1.85	1.87	2.07	2.07	2.07	2.08	2.31	2.31	2.31	2.32	2.57	2.57	2.57	2.58	2.86	2.86	2.86	2.87	3.20	3.20	3.20	3.21	
1350	Capacity	37276	37776	38834	40449	36959	37459	38517	40132	36034	36535	37592	39208	34444	34944	36002	37617	32500	33000	34058	35673	30725	31225	32283	33898
	S/T	1.00	1.00	0.87	0.72	1.00	1.00	0.88	0.73	1.00	1.00	0.90	0.75	1.00	1.00	0.92	0.77	1.00	1.00	1.00	0.80	1.00	1.00	1.00	0.85
	Evap dT	29	27	23	20	28	27	23	20	29	27	24	20	28	27	23	20	28	26	23	20	29	28	24	21
	Pr Suc	130	131	135	140	137	139	142	147	144	146	149	154	150	151	154	160	155	157	160	165	162	163	167	172
	Pr Dis	242	243	244	249	279	280	282	286	318	319	321	325	360	361	363	367	405	406	408	412	454	455	456	460
Amps	6.6	6.6	6.6	6.7	7.5	7.5	7.5	7.6	8.6	8.6	8.6	8.6	9.7	9.7	9.7	9.8	11.0	11.0	11.0	11.0	12.5	12.5	12.4	12.5	
kW	1.87	1.86	1.86	1.88	2.08	2.08	2.08	2.09	2.32	2.32	2.32	2.33	2.58	2.58	2.58	2.59	2.87	2.87	2.87	2.88	3.21	3.21	3.21	3.22	

IDB: Entering Indoor Dry Bulb Temperature
 High and low pressures are measured at the liquid and suction service valves.
 Shaded area reflects AHRl (TVA) conditions
 kW = Total system power
 Amps = outdoor unit amps (compressor + fan)

EXPANDING COOLING DATA — GLZT7CA3610A*+DMVT42CP1300A* (70%)

IDB	AIRFLOW	OUTDOOR AMBIENT TEMPERATURE																							
		65°F				75°F				85°F				95°F				105°F				115°F			
		59	63	67	71	59	63	67	71	59	63	67	71	59	63	67	71	59	63	67	71	59	63	67	71
70	Capacity	25474	25834	26594	-	25246	25606	26366	-	24582	24941	25702	-	23438	23798	24558	-	22040	22400	23160	-	20764	21124	21884	-
	S/T	0.64	0.56	0.42	-	0.65	0.57	0.43	-	0.68	0.60	0.45	-	1.00	0.62	0.47	-	1.00	0.64	0.50	-	1.00	0.69	0.55	-
	Evap dT	18	17	14	-	18	17	14	-	19	17	14	-	18	17	14	-	18	16	13	-	19	18	14	-
	Pr Suc	127	129	132	-	135	136	140	-	142	143	146	-	147	149	152	-	153	154	158	-	160	161	165	-
	Pr Dis	127	227	228	-	261	262	264	-	298	299	301	-	339	340	341	-	382	383	384	-	428	429	431	-
	Amps	4.1	4.1	4.1	-	4.7	4.7	4.7	-	5.3	5.3	5.3	-	6.0	6.0	6.0	-	6.8	6.8	6.8	-	7.8	7.8	7.8	-
	kW	1.16	1.16	1.15	-	1.29	1.29	1.29	-	1.44	1.44	1.44	-	1.61	1.61	1.60	-	1.79	1.79	1.79	-	2.01	2.00	2.00	-
	Capacity	25791	26150	26911	-	25563	25922	26683	-	24898	25258	26018	-	23754	24114	24874	-	22357	22716	23477	-	21081	21440	22201	-
	S/T	0.70	0.62	0.48	-	0.71	0.63	0.49	-	1.00	0.66	0.51	-	1.00	0.68	0.53	-	1.00	0.70	0.56	-	1.00	0.75	0.61	-
	Evap dT	18	16	13	-	17	16	13	-	18	16	13	-	17	16	13	-	17	16	12	-	18	17	13	-
Pr Suc	129	130	134	-	137	138	141	-	143	145	148	-	149	151	154	-	155	156	159	-	162	163	166	-	
Pr Dis	227	228	230	-	263	264	266	-	300	301	303	-	340	341	343	-	384	385	386	-	430	431	432	-	
Amps	4.1	4.1	4.1	-	4.7	4.7	4.7	-	5.4	5.4	5.4	-	6.1	6.1	6.1	-	6.9	6.9	6.9	-	7.8	7.8	7.8	-	
kW	1.16	1.16	1.16	-	1.30	1.30	1.30	-	1.45	1.45	1.45	-	1.61	1.61	1.61	-	1.80	1.80	1.79	-	2.01	2.01	2.01	-	
Capacity	26226	26585	27346	-	25998	26357	27118	-	25333	25693	26453	-	24189	24549	25309	-	22792	23151	23912	-	21516	21875	22636	-	
S/T	0.74	0.66	0.52	-	0.75	0.67	0.52	-	1.00	0.69	0.55	-	1.00	0.71	0.57	-	1.00	0.74	0.59	-	1.00	1.00	0.65	-	
Evap dT	17	15	12	-	17	15	12	-	17	15	12	-	17	15	12	-	16	15	11	-	17	16	12	-	
Pr Suc	131	133	136	-	139	140	144	-	146	147	150	-	151	153	156	-	157	158	162	-	164	165	169	-	
Pr Dis	229	230	232	-	265	266	268	-	302	303	305	-	342	343	345	-	386	387	388	-	432	433	434	-	
Amps	4.1	4.1	4.1	-	4.7	4.7	4.7	-	5.4	5.4	5.4	-	6.1	6.1	6.1	-	6.9	6.9	6.9	-	7.8	7.8	7.8	-	
kW	1.17	1.17	1.17	-	1.31	1.31	1.30	-	1.46	1.46	1.45	-	1.62	1.62	1.62	-	1.80	1.80	1.80	-	2.02	2.02	2.02	-	

75	Capacity	25489	25849	26609	27771	25261	25621	26381	27543	24597	24956	25717	26878	23453	23812	24573	25734	22055	22415	23175	24337	20779	21139	21899	23061
	S/T	0.78	0.70	0.56	0.41	1.00	0.71	0.56	0.41	1.00	0.73	0.59	0.44	1.00	0.75	0.61	0.46	1.00	0.78	0.63	0.48	1.00	1.00	0.69	0.54
	Evap dT	22	21	17	14	22	21	17	14	22	21	17	13	22	20	17	14	22	20	17	14	23	21	18	15
	Pr Suc	127	129	132	137	135	136	140	145	142	143	146	152	147	149	152	158	153	154	158	163	160	162	165	170
	Pr Dis	226	227	228	232	261	262	264	268	299	300	301	305	339	340	341	345	382	383	385	389	428	429	431	435
	Amps	4.1	4.1	4.1	4.1	4.7	4.7	4.7	4.7	5.3	5.3	5.3	5.4	6.0	6.0	6.0	6.1	6.8	6.8	6.8	6.9	7.8	7.8	7.8	7.8
	kW	1.16	1.16	1.15	1.16	1.29	1.29	1.29	1.30	1.44	1.44	1.44	1.45	1.61	1.61	1.60	1.61	1.79	1.79	1.79	1.80	2.00	2.00	2.00	2.01
	Capacity	25805	26165	26925	28087	25578	25937	26698	27859	24913	25272	26033	27194	23769	24129	24889	26051	22371	22731	23491	24653	21096	21455	22215	23377
	S/T	0.84	0.76	0.62	0.46	1.00	0.77	0.62	0.47	1.00	0.79	0.65	0.50	1.00	0.81	0.67	0.52	1.00	1.00	0.69	0.54	1.00	1.00	0.75	0.60
	Evap dT	21	20	16	13	21	20	16	13	21	20	17	13	21	20	16	13	21	19	16	13	22	20	17	14
Pr Suc	129	130	134	139	137	138	141	147	143	145	148	154	149	151	154	159	155	156	159	165	162	163	167	172	
Pr Dis	228	229	230	234	263	264	266	270	300	301	303	307	341	342	343	347	384	385	386	390	430	431	433	437	
Amps	4.1	4.1	4.1	4.1	4.7	4.7	4.7	4.7	5.4	5.4	5.3	5.4	6.1	6.1	6.1	6.1	6.9	6.9	6.9	6.9	7.8	7.8	7.8	7.8	
kW	1.16	1.16	1.16	1.17	1.30	1.30	1.30	1.31	1.45	1.45	1.45	1.46	1.61	1.61	1.61	1.62	1.80	1.80	1.79	1.80	2.01	2.01	2.01	2.02	
Capacity	26241	26600	27361	28522	26013	26372	27133	28294	25348	25708	26468	27630	24204	24564	25324	26486	22807	23166	23927	25088	21531	21890	22651	23812	
S/T	0.88	0.80	0.65	0.50	1.00	0.80	0.66	0.51	1.00	0.83	0.69	0.54	1.00	0.85	0.71	0.56	1.00	1.00	0.73	0.58	1.00	1.00	0.78	0.63	
Evap dT	20	19	15	12	20	19	15	12	21	19	16	12	20	19	15	12	20	18	15	12	21	19	16	13	
Pr Suc	131	133	136	141	139	140	144	149	146	147	150	156	151	153	156	162	157	158	162	167	164	166	169	174	
Pr Dis	230	231	232	236	265	266	268	272	302	303	305	309	343	344	345	349	386	387	388	392	432	433	435	439	
Amps	4.1	4.1	4.1	4.2	4.7	4.7	4.7	4.8	5.4	5.4	5.4	5.4	6.1	6.1	6.1	6.1	6.9	6.9	6.9	6.9	7.8	7.8	7.8	7.9	
kW	1.17	1.17	1.17	1.18	1.31	1.30	1.30	1.31	1.46	1.46	1.45	1.46	1.62	1.62	1.62	1.63	1.80	1.80	1.80	1.81	2.02	2.02	2.02	2.02	

IDB: Entering Indoor Dry Bulb Temperature
 High and low pressures are measured at the liquid and suction service valves.
 Shaded area reflects ACCA (TVA) conditions
 kW = Total system power
 Amps = outdoor unit amps (compressor + fan)

EXPANDING COOLING DATA — GLZT7CA3610A*+DMVT42CP1300A* (70%) (CONT.)

IDB	AIRFLOW	OUTDOOR AMBIENT TEMPERATURE																							
		65°F				75°F				85°F				95°F				105°F				115°F			
		59	63	67	71	59	63	67	71	59	63	67	71	59	63	67	71	59	63	67	71	59	63	67	71
80	Capacity	25621	25981	26741	27903	25393	25753	26513	27675	24728	25088	25848	27010	23585	23944	24705	25866	22187	22547	23307	24469	20911	21271	22031	23193
	S/T	1.00	0.83	0.69	0.54	1.00	0.84	0.70	0.54	1.00	0.87	0.72	0.57	1.00	1.00	0.74	0.59	1.00	1.00	0.77	0.62	1.00	1.00	0.82	0.67
	Evap dT	26	24	21	18	26	24	21	18	26	25	21	18	26	24	21	18	26	24	21	18	27	25	22	19
	Pr Suc	128	129	132	138	135	137	140	146	142	144	147	152	148	149	153	158	153	155	158	164	161	162	165	171
	Pr Dis	226	227	229	233	262	263	264	268	299	300	302	306	339	340	342	346	383	384	385	389	429	430	431	435
	Amps	4.1	4.1	4.1	4.1	4.7	4.7	4.7	4.7	5.3	5.3	5.3	5.4	6.0	6.0	6.0	6.1	6.8	6.8	6.8	6.9	7.8	7.8	7.8	7.8
kW	1.16	1.16	1.15	1.16	1.29	1.29	1.29	1.30	1.44	1.44	1.44	1.45	1.61	1.61	1.60	1.61	1.79	1.79	1.79	1.80	2.01	2.00	2.00	2.01	
Capacity	25937	26297	27057	28219	25709	26069	26829	27991	25045	25404	26165	27326	23901	24261	25021	26183	22503	22863	23623	24785	21227	21587	22347	23509	
S/T	1.00	0.89	0.75	0.60	1.00	0.90	0.75	0.60	1.00	1.00	0.78	0.63	1.00	1.00	0.80	0.65	1.00	1.00	0.82	0.67	1.00	1.00	1.00	0.73	
Evap dT	25	23	20	17	25	23	20	17	25	24	20	17	25	23	20	17	25	23	20	17	26	24	21	18	
Pr Suc	129	131	134	140	137	139	142	147	144	145	149	154	150	151	154	160	155	157	160	165	162	164	167	172	
Pr Dis	228	229	231	235	264	265	266	270	301	302	303	307	341	342	344	348	384	385	387	391	431	432	433	437	
Amps	4.1	4.1	4.1	4.1	4.7	4.7	4.7	4.7	5.4	5.4	5.4	5.4	6.1	6.1	6.1	6.1	6.9	6.9	6.9	6.9	7.8	7.8	7.8	7.8	
kW	1.16	1.16	1.16	1.17	1.30	1.30	1.30	1.31	1.45	1.45	1.45	1.46	1.61	1.61	1.61	1.62	1.80	1.80	1.80	1.81	2.01	2.01	2.01	2.02	
Capacity	26372	26732	27492	28654	26145	26504	27265	28426	25480	25839	26600	27761	24336	24696	25456	26618	22938	23298	24058	25220	21663	22022	22782	23944	
S/T	1.00	0.93	0.79	0.63	1.00	0.93	0.79	0.64	1.00	1.00	0.82	0.67	1.00	1.00	0.84	0.69	1.00	1.00	0.86	0.71	1.00	1.00	1.00	0.77	
Evap dT	24	22	19	16	24	22	19	16	24	23	19	16	24	22	19	16	24	22	19	16	25	23	20	17	
Pr Suc	132	133	136	142	139	141	144	150	146	148	151	156	152	153	157	162	157	159	162	168	165	166	169	175	
Pr Dis	230	231	233	237	266	267	268	272	303	304	305	309	343	344	346	350	386	387	389	393	433	434	435	439	
Amps	4.1	4.1	4.1	4.2	4.7	4.7	4.7	4.8	5.4	5.4	5.4	5.4	6.1	6.1	6.1	6.1	6.9	6.9	6.9	6.9	7.8	7.8	7.8	7.9	
kW	1.17	1.17	1.17	1.18	1.31	1.30	1.30	1.31	1.46	1.46	1.46	1.46	1.62	1.62	1.62	1.63	1.80	1.80	1.80	1.81	2.02	2.02	2.02	2.03	

85	Capacity	26050	26409	27170	28332	25822	26182	26942	28104	25157	25517	26277	27439	24014	24373	25134	26295	22616	22976	23736	24898	21340	21700	22460	23622
	S/T	1.00	0.94	0.80	0.65	1.00	1.00	0.80	0.65	1.00	1.00	0.83	0.68	1.00	1.00	0.85	0.70	1.00	1.00	1.00	0.72	1.00	1.00	1.00	0.78
	Evap dT	29	28	25	21	29	28	24	21	30	28	25	21	29	28	24	21	29	27	24	21	30	29	25	22
	Pr Suc	130	131	134	140	137	139	142	148	144	146	149	154	150	151	155	160	155	157	160	166	162	164	167	173
	Pr Dis	227	228	230	234	263	264	265	269	300	301	303	307	340	341	343	347	384	385	386	390	430	431	432	436
	Amps	4.1	4.1	4.1	4.1	4.7	4.7	4.7	4.7	5.3	5.3	5.3	5.4	6.1	6.1	6.0	6.1	6.9	6.8	6.8	6.9	7.8	7.8	7.8	7.8
kW	1.16	1.16	1.16	1.17	1.30	1.29	1.29	1.30	1.45	1.45	1.44	1.45	1.61	1.61	1.61	1.62	1.79	1.79	1.79	1.80	2.01	2.01	2.00	2.01	
Capacity	26366	26726	27486	28648	26138	26498	27258	28420	25474	25833	26594	27755	24330	24690	25450	26612	22932	23292	24052	25214	21656	22016	22776	23938	
S/T	1.00	1.00	0.85	0.70	1.00	1.00	0.86	0.71	1.00	1.00	0.89	0.74	1.00	1.00	0.91	0.76	1.00	1.00	1.00	0.78	1.00	1.00	1.00	0.83	
Evap dT	28	27	24	20	28	27	24	20	29	27	24	20	28	27	23	20	28	26	23	20	29	28	24	21	
Pr Suc	131	133	136	142	139	141	144	149	146	147	151	156	152	153	156	162	157	159	162	167	164	166	169	174	
Pr Dis	229	230	232	236	265	266	267	271	302	303	305	308	342	343	345	349	385	386	388	392	432	433	434	438	
Amps	4.1	4.1	4.1	4.2	4.7	4.7	4.7	4.7	5.4	5.4	5.4	5.4	6.1	6.1	6.1	6.1	6.9	6.9	6.9	6.9	7.8	7.8	7.8	7.8	
kW	1.17	1.17	1.16	1.17	1.30	1.30	1.30	1.31	1.45	1.45	1.45	1.46	1.62	1.62	1.61	1.62	1.80	1.80	1.80	1.81	2.01	2.01	2.01	2.02	
Capacity	26801	27161	27921	29083	26573	26933	27693	28855	25909	26268	27029	28190	24765	25125	25885	27047	23367	23727	24487	25649	22091	22451	23211	24373	
S/T	1.00	1.00	0.89	0.74	1.00	1.00	0.90	0.75	1.00	1.00	0.93	0.77	1.00	1.00	1.00	0.79	1.00	1.00	1.00	0.82	1.00	1.00	1.00	0.87	
Evap dT	28	26	23	19	27	26	23	19	28	26	23	19	27	26	23	19	27	26	22	19	28	27	23	20	
Pr Suc	134	135	138	144	141	143	146	151	148	150	153	158	154	155	159	164	159	161	164	170	166	168	171	177	
Pr Dis	231	232	234	238	267	268	269	273	304	305	307	310	344	345	347	351	387	388	390	394	434	435	436	440	
Amps	4.2	4.2	4.1	4.2	4.7	4.7	4.7	4.8	5.4	5.4	5.4	5.4	6.1	6.1	6.1	6.1	6.9	6.9	6.9	6.9	7.8	7.8	7.8	7.9	
kW	1.17	1.17	1.17	1.18	1.31	1.31	1.31	1.32	1.46	1.46	1.46	1.47	1.62	1.62	1.62	1.63	1.81	1.81	1.80	1.81	2.02	2.02	2.02	2.03	

IDB: Entering Indoor Dry Bulb Temperature
 High and low pressures are measured at the liquid and suction service valves.
 Shaded area reflects AHRl (TVA) conditions
 kW = Total system power
 Amps = outdoor unit amps (compressor + fan)

EXPANDING COOLING DATA — GLZT7CA4810A*+DMVT60DP1300A* (CONT.)

IDB	AIRFLOW	OUTDOOR AMBIENT TEMPERATURE																							
		65°F				75°F				95°F				105°F				115°F							
		59	63	67	71	59	63	67	71	59	63	67	71	59	63	67	71	59	63	67	71				
80	Capacity	47768	48436	49850	52008	47345	48013	49426	51585	46109	46778	48191	50350	43984	44652	46065	48224	41386	42055	43468	45627	39015	39683	41097	43255
	S/T	1.00	0.81	0.67	0.53	1.00	0.84	0.70	0.56	1.00	0.86	0.72	0.58	1.00	0.86	0.72	0.58	1.00	1.00	0.74	0.60	1.00	1.00	0.80	0.65
	Evap dT	28	26	23	19	28	26	23	19	28	26	22	19	28	26	22	19	27	26	22	19	29	27	23	20
	Pr Suc	124	125	128	134	131	133	136	141	138	139	142	148	143	145	148	153	149	150	153	159	156	157	160	165
	Pr Dis	248	249	251	255	287	288	290	294	327	329	330	335	371	372	374	378	419	420	421	426	469	470	472	476
	Amps	8.9	8.9	8.9	9.0	10.2	10.2	10.2	10.2	11.6	11.6	11.6	11.7	13.1	13.1	13.1	13.2	14.8	14.8	14.8	14.9	16.8	16.8	16.8	16.9
	kW	2.49	2.49	2.49	2.51	2.78	2.78	2.78	2.80	3.11	3.10	3.10	3.12	3.46	3.45	3.45	3.47	3.85	3.84	3.84	3.86	4.30	4.30	4.30	4.32
	Capacity	48203	48871	50284	52443	47779	48447	49860	52019	46544	47212	48625	50784	44418	45086	46500	48658	41821	42489	43902	46061	39449	40118	41531	43690
	S/T	1.00	0.85	0.71	0.57	1.00	0.85	0.72	0.57	1.00	0.88	0.74	0.60	1.00	1.00	0.76	0.62	1.00	1.00	0.78	0.64	1.00	1.00	0.83	0.69
	Evap dT	27	25	22	18	27	25	22	18	27	25	22	18	27	25	22	18	27	25	21	18	28	26	23	19
Pr Suc	125	127	130	135	133	134	137	142	139	141	144	149	145	146	149	154	150	152	155	160	157	158	161	167	
Pr Dis	249	250	252	256	288	289	291	295	329	330	332	336	373	374	376	380	420	421	423	427	471	472	473	478	
Amps	9.0	9.0	8.9	9.0	10.2	10.2	10.2	10.3	11.6	11.6	11.6	11.7	13.2	13.1	13.1	13.2	14.9	14.8	14.8	14.9	16.8	16.8	16.8	16.9	
kW	2.50	2.50	2.50	2.52	2.79	2.79	2.78	2.81	3.12	3.11	3.11	3.13	3.47	3.46	3.46	3.48	3.86	3.85	3.85	3.87	4.31	4.31	4.31	4.33	
Capacity	49299	49967	51380	53539	48875	49543	50957	53115	47640	48308	49721	51880	45514	46183	47596	49754	42917	43585	44998	47157	40546	41214	42627	44786	
S/T	1.00	0.89	0.75	0.61	1.00	0.89	0.76	0.61	1.00	0.92	0.78	0.64	1.00	1.00	0.80	0.66	1.00	1.00	0.82	0.68	1.00	1.00	0.88	0.73	
Evap dT	26	24	20	17	26	24	20	17	26	24	21	17	26	24	20	17	25	24	20	17	27	25	21	18	
Pr Suc	128	129	133	138	135	137	140	145	142	143	147	152	147	149	152	157	153	154	158	163	160	161	164	170	
Pr Dis	252	253	255	259	291	292	294	298	332	333	335	339	376	377	378	383	423	424	426	430	473	474	476	480	
Amps	9.0	9.0	9.0	9.1	10.3	10.3	10.3	10.4	11.7	11.7	11.7	11.8	13.2	13.2	13.2	13.3	14.9	14.9	14.9	15.0	16.9	16.9	16.9	17.0	
kW	2.52	2.52	2.51	2.53	2.81	2.81	2.80	2.82	3.13	3.13	3.13	3.15	3.48	3.48	3.48	3.50	3.87	3.87	3.87	3.89	4.33	4.33	4.33	4.35	

85	Capacity	48565	49234	50647	52805	48142	48810	50223	52382	46907	47575	48988	51147	44781	45449	46863	49021	42184	42852	44265	46424	39812	40480	41894	44052
	S/T	1.00	0.91	0.77	0.63	1.00	0.92	0.78	0.64	1.00	1.00	0.80	0.66	1.00	1.00	0.82	0.68	1.00	1.00	0.85	0.70	1.00	1.00	1.00	0.75
	Evap dT	31	30	26	23	31	30	26	23	32	30	26	23	31	30	26	22	31	29	26	22	32	30	27	23
	Pr Suc	126	127	130	136	133	135	138	143	140	141	144	150	145	147	150	155	151	152	155	160	157	159	162	167
	Pr Dis	249	250	252	256	288	289	291	295	329	330	331	336	372	374	375	380	420	421	423	427	470	471	473	477
	Amps	8.9	8.9	8.9	9.0	10.2	10.2	10.2	10.3	11.6	11.6	11.6	11.7	13.1	13.1	13.1	13.2	14.8	14.8	14.8	14.9	16.8	16.8	16.8	16.9
	kW	2.50	2.50	2.49	2.51	2.79	2.79	2.78	2.80	3.11	3.11	3.11	3.13	3.46	3.46	3.46	3.48	3.85	3.85	3.84	3.87	4.31	4.31	4.31	4.33
	Capacity	49000	49668	51081	53240	48576	49244	50658	52816	47341	48009	49422	51581	45215	45884	47297	49456	42618	43286	44699	46858	40247	40915	42328	44487
	S/T	1.00	0.95	0.81	0.67	1.00	1.00	0.82	0.67	1.00	1.00	0.84	0.70	1.00	1.00	0.86	0.72	1.00	1.00	0.88	0.74	1.00	1.00	1.00	0.79
	Evap dT	31	29	25	22	31	29	25	22	31	29	26	22	31	29	25	22	30	29	25	22	32	30	26	23
Pr Suc	127	128	132	137	134	136	139	144	141	142	146	151	146	148	151	156	152	153	156	162	159	160	163	168	
Pr Dis	250	251	253	257	289	290	292	296	330	331	333	337	374	375	377	381	421	422	424	428	472	473	474	479	
Amps	9.0	9.0	9.0	9.1	10.3	10.2	10.2	10.3	11.7	11.6	11.6	11.7	13.2	13.2	13.1	13.2	14.9	14.9	14.8	14.9	16.9	16.9	16.8	16.9	
kW	2.51	2.51	2.50	2.52	2.80	2.80	2.79	2.81	3.12	3.12	3.12	3.14	3.47	3.47	3.46	3.49	3.86	3.86	3.85	3.88	4.32	4.32	4.32	4.34	
Capacity	50096	50764	52177	54336	49672	50340	51754	53912	48437	49105	50518	52677	46311	46980	48393	50552	43714	44382	45795	47954	41343	42011	43424	45583	
S/T	1.00	0.99	0.85	0.71	1.00	1.00	0.86	0.72	1.00	1.00	0.88	0.74	1.00	1.00	0.90	0.76	1.00	1.00	1.00	0.78	1.00	1.00	1.00	0.83	
Evap dT	29	28	24	20	29	28	24	20	30	28	24	20	29	27	24	20	29	27	24	20	30	28	25	21	
Pr Suc	130	131	134	140	137	139	142	147	144	145	148	154	149	151	154	159	155	156	159	165	162	163	166	171	
Pr Dis	253	254	256	260	292	293	295	299	333	334	336	340	377	378	380	384	424	425	427	431	475	476	477	482	
Amps	9.1	9.1	9.0	9.1	10.3	10.3	10.3	10.4	11.7	11.7	11.7	11.8	13.3	13.2	13.2	13.3	15.0	14.9	14.9	15.0	16.9	16.9	16.9	17.0	
kW	2.53	2.52	2.52	2.54	2.81	2.81	2.81	2.83	3.14	3.14	3.14	3.15	3.49	3.49	3.48	3.50	3.88	3.88	3.87	3.89	4.34	4.34	4.34	4.35	

IDB: Entering Indoor Dry Bulb Temperature
 High and low pressures are measured at the liquid and suction service valves.
 Shaded area reflects AHRl (TVA) conditions
 kW = Total system power
 Amps = outdoor unit amps (compressor + fan)

EXPANDING COOLING DATA — GLZT7CA4810A*+DMVT60DP1300A* (70%)

IDB	AIRFLOW	OUTDOOR AMBIENT TEMPERATURE																							
		65°F				75°F				85°F				95°F				105°F				115°F			
		59	63	67	71	59	63	67	71	59	63	67	71	59	63	67	71	59	63	67	71	59	63	67	71
70	Capacity	34149	34630	35646	-	33845	34325	35341	-	32957	33437	34453	-	31428	31909	32925	-	29561	30041	31057	-	27856	28336	29352	-
	S/T	0.65	0.57	0.43	-	0.65	0.57	0.43	-	0.68	0.60	0.46	-	1.00	0.62	0.48	-	1.00	0.64	0.50	-	1.00	0.70	0.56	-
	Evap dT	19	17	14	-	19	17	14	-	19	17	14	-	19	17	14	-	19	17	14	-	20	18	15	-
	Pr Suc	127	128	131	-	134	136	139	-	141	143	146	-	147	148	152	-	152	154	157	-	159	161	164	-
	Pr Dis	127	237	239	-	273	274	276	-	312	313	315	-	354	355	357	-	400	401	402	-	448	449	451	-
	Amps	5.6	5.6	5.6	-	6.4	6.4	6.4	-	7.3	7.3	7.3	-	8.2	8.2	8.2	-	9.3	9.3	9.3	-	10.6	10.6	10.6	-
	kW	1.57	1.57	1.56	-	1.75	1.75	1.75	-	1.95	1.95	1.95	-	2.17	2.17	2.17	-	2.42	2.42	2.42	-	2.71	2.71	2.70	-
	Capacity	34462	34942	35958	-	34157	34638	35654	-	33269	33749	34765	-	31741	32221	33237	-	29873	30354	31370	-	28168	28649	29665	-
	S/T	0.68	0.61	0.47	-	0.69	0.61	0.47	-	0.72	0.64	0.50	-	1.00	0.66	0.52	-	1.00	0.68	0.54	-	1.00	0.73	0.59	-
	Evap dT	18	16	13	-	18	16	13	-	18	17	13	-	18	16	13	-	18	16	13	-	19	17	14	-
Pr Suc	128	130	133	-	136	137	140	-	142	144	147	-	148	150	153	-	154	155	158	-	161	162	165	-	
Pr Dis	238	239	240	-	275	276	277	-	314	315	316	-	356	357	358	-	401	402	404	-	449	450	452	-	
Amps	5.6	5.6	5.6	-	6.4	6.4	6.4	-	7.3	7.3	7.3	-	8.3	8.3	8.3	-	9.3	9.3	9.3	-	10.6	10.6	10.6	-	
kW	1.57	1.57	1.57	-	1.76	1.75	1.75	-	1.96	1.96	1.96	-	2.18	2.18	2.18	-	2.43	2.42	2.42	-	2.71	2.71	2.71	-	
Capacity	35250	35730	36746	-	34945	35426	36442	-	34057	34537	35553	-	32529	33009	34025	-	30661	31142	32158	-	28956	29437	30453	-	
S/T	0.73	0.65	0.51	-	0.73	0.66	0.52	-	1.00	0.68	0.54	-	1.00	0.70	0.56	-	1.00	0.72	0.58	-	1.00	1.00	0.64	-	
Evap dT	17	15	12	-	17	15	12	-	17	15	12	-	17	15	12	-	17	15	12	-	18	16	13	-	
Pr Suc	131	132	136	-	139	140	143	-	145	147	150	-	151	153	156	-	157	158	161	-	164	165	168	-	
Pr Dis	240	241	243	-	278	279	280	-	317	318	319	-	358	359	361	-	404	405	406	-	452	453	455	-	
Amps	5.7	5.7	5.7	-	6.5	6.5	6.5	-	7.4	7.4	7.3	-	8.3	8.3	8.3	-	9.4	9.4	9.4	-	10.6	10.6	10.6	-	
kW	1.59	1.58	1.58	-	1.77	1.77	1.76	-	1.97	1.97	1.97	-	2.19	2.19	2.19	-	2.44	2.44	2.43	-	2.72	2.72	2.72	-	

75	Capacity	34177	34657	35673	37226	34177	34657	35673	37226	33289	33769	34785	36337	31761	32241	33257	34809	29893	30373	31389	32942	28188	28668	29685	31237
	S/T	0.82	0.74	0.60	0.45	1.00	0.75	0.61	0.46	1.00	0.77	0.63	0.48	1.00	0.79	0.65	0.50	1.00	1.00	0.67	0.53	1.00	1.00	0.73	0.58
	Evap dT	22	20	17	14	22	20	17	14	22	21	17	14	22	20	17	14	22	20	17	13	23	21	18	14
	Pr Suc	128	130	133	138	136	137	140	146	142	144	147	153	148	150	153	158	154	155	158	164	161	162	165	171
	Pr Dis	238	239	241	245	275	276	278	282	314	315	317	321	356	357	359	363	401	402	404	408	449	450	452	456
	Amps	5.6	5.6	5.6	5.7	6.4	6.4	6.4	6.5	7.3	7.3	7.3	7.4	8.3	8.3	8.2	8.3	9.3	9.3	9.3	9.4	10.6	10.6	10.6	10.6
	kW	1.57	1.57	1.57	1.58	1.76	1.75	1.74	1.76	1.95	1.95	1.95	1.96	2.17	2.18	2.17	2.17	2.42	2.42	2.42	2.43	2.71	2.71	2.71	2.72
	Capacity	34481	34962	35978	37530	34177	34657	35673	37226	33289	33769	34785	36337	31761	32241	33257	34809	29893	30373	31389	32942	28188	28668	29685	31237
	S/T	0.86	0.78	0.64	0.50	1.00	0.79	0.65	0.50	1.00	0.81	0.67	0.53	1.00	0.79	0.65	0.50	1.00	1.00	0.72	0.57	1.00	1.00	0.77	0.62
	Evap dT	21	19	16	12	21	19	16	12	21	19	16	13	21	20	19	16	21	19	15	12	22	20	17	13
Pr Suc	131	133	136	141	139	140	143	149	145	147	150	156	151	153	156	161	157	158	161	167	164	165	168	174	
Pr Dis	241	242	243	247	278	279	280	285	317	318	319	323	359	360	361	365	404	405	407	411	452	453	455	459	
Amps	5.7	5.7	5.7	5.7	6.5	6.5	6.5	6.5	7.4	7.4	7.3	7.4	8.3	8.3	8.3	8.4	9.4	9.4	9.4	9.4	10.6	10.6	10.6	10.7	
kW	1.58	1.58	1.58	1.59	1.77	1.76	1.76	1.78	1.97	1.97	1.97	1.98	2.19	2.18	2.18	2.20	2.44	2.43	2.43	2.44	2.72	2.72	2.72	2.73	

IDB: Entering Indoor Dry Bulb Temperature
 High and low pressures are measured at the liquid and suction service valves.
 Shaded area reflects ACCA (TVA) conditions
 kW = Total system power
 Amps = outdoor unit amps (compressor + fan)

EXPANDING COOLING DATA — GLZT7CA4810A*+DMVT60DP1300A* (70%) (CONT.)

IDB	AIRFLOW	OUTDOOR AMBIENT TEMPERATURE																							
		65°F				75°F				85°F				95°F				105°F				115°F			
		59	63	67	71	59	63	67	71	59	63	67	71	59	63	67	71	59	63	67	71	59	63	67	71
80	Capacity	34345	34826	35842	37394	34041	34521	35537	37090	33153	33633	34649	36201	31624	32105	33121	34673	29757	30237	31253	32806	28052	28532	29548	31101
	S/T	1.00	0.83	0.69	0.54	1.00	0.84	0.70	0.55	1.00	0.86	0.72	0.58	1.00	1.00	0.74	0.60	1.00	1.00	0.76	0.62	1.00	1.00	0.82	0.67
	Evap dT	27	25	22	18	27	25	22	18	27	25	22	18	27	25	22	18	27	25	21	18	28	26	23	19
	Pr Suc	127	129	132	137	135	137	140	145	142	143	146	152	147	149	152	157	153	154	158	163	160	161	165	170
	Pr Dis	237	238	240	244	274	275	277	281	313	314	316	320	355	356	358	362	400	401	403	407	448	449	451	455
Amps	5.6	5.6	5.6	5.7	6.4	6.4	6.4	6.4	7.3	7.3	7.3	7.3	8.2	8.2	8.3	8.3	9.3	9.3	9.3	9.4	10.6	10.6	10.6	10.6	
kW	1.57	1.57	1.57	1.58	1.75	1.75	1.75	1.76	1.95	1.95	1.95	1.96	2.17	2.17	2.17	2.18	2.42	2.42	2.42	2.43	2.71	2.71	2.71	2.72	
Capacity	34658	35138	36154	37706	34353	34834	35850	37402	33465	33945	34961	36514	31937	32417	33433	34985	30069	30550	31566	33118	28364	28845	29861	31413	
S/T	1.00	0.87	0.73	0.58	1.00	0.87	0.74	0.59	1.00	0.90	0.76	0.61	1.00	1.00	0.78	0.63	1.00	1.00	0.80	0.66	1.00	1.00	0.86	0.71	
Evap dT	26	24	21	18	26	24	21	17	26	25	21	18	26	24	21	17	26	24	21	17	27	25	22	18	
Pr Suc	129	130	133	139	136	138	141	146	143	145	148	153	149	150	153	159	154	156	159	164	161	163	166	171	
Pr Dis	238	239	241	245	275	276	278	282	314	315	317	321	356	357	359	363	402	403	404	408	450	451	452	457	
Amps	5.6	5.6	5.6	5.7	6.4	6.4	6.4	6.5	7.3	7.3	7.3	7.4	8.3	8.3	8.3	8.3	9.3	9.3	9.3	9.4	10.6	10.6	10.6	10.6	
kW	1.57	1.57	1.57	1.58	1.76	1.76	1.76	1.77	1.96	1.96	1.96	1.97	2.19	2.19	2.17	2.19	2.43	2.43	2.43	2.44	2.71	2.71	2.71	2.72	
Capacity	35446	35926	36942	38494	35141	35622	36638	38190	34253	34733	35750	37302	32725	33205	34221	35773	30857	31338	32354	33906	29152	29633	30649	32201	
S/T	1.00	0.91	0.77	0.62	1.00	0.92	0.78	0.63	1.00	1.00	0.80	0.66	1.00	1.00	0.82	0.68	1.00	1.00	0.85	0.70	1.00	1.00	0.86	0.71	
Evap dT	25	23	20	16	25	23	20	16	25	23	20	17	25	23	20	16	25	23	19	16	26	24	21	17	
Pr Suc	132	133	136	142	139	141	144	149	146	147	151	156	152	153	156	162	157	159	162	167	164	166	169	174	
Pr Dis	241	242	244	248	278	279	281	285	317	318	320	324	359	360	362	366	404	405	407	411	453	454	455	459	
Amps	5.7	5.7	5.7	5.7	6.5	6.5	6.5	6.5	7.4	7.4	7.3	7.4	8.3	8.3	8.3	8.4	9.4	9.4	9.4	9.4	10.6	10.6	10.6	10.7	
kW	1.58	1.58	1.58	1.59	1.77	1.77	1.76	1.78	1.97	1.97	1.97	1.98	2.19	2.19	2.19	2.20	2.44	2.43	2.43	2.45	2.72	2.72	2.72	2.73	

80	Capacity	34918	35399	36415	37967	34614	35094	36111	37663	33726	34206	35222	36774	32198	32678	33694	35246	30330	30810	31827	33379	28625	29105	30122	31674
	S/T	1.00	0.93	0.79	0.65	1.00	1.00	0.80	0.65	1.00	1.00	0.83	0.68	1.00	1.00	0.85	0.70	1.00	1.00	0.72	0.57	1.00	1.00	0.77	0.62
	Evap dT	30	29	25	22	30	29	25	22	31	29	25	22	30	28	25	22	30	28	25	21	31	29	26	23
	Pr Suc	129	131	134	139	137	138	142	147	144	145	148	154	149	151	154	159	155	156	160	165	162	163	167	172
	Pr Dis	238	239	241	245	275	276	278	282	314	315	317	321	356	357	359	363	401	402	404	408	450	451	452	456
Amps	5.6	5.6	5.6	5.7	6.4	6.4	6.4	6.5	7.3	7.3	7.3	7.3	8.3	8.3	8.2	8.3	9.3	9.3	9.3	9.4	10.6	10.6	10.6	10.6	
kW	1.57	1.57	1.57	1.58	1.75	1.75	1.75	1.76	1.96	1.96	1.96	1.97	2.18	2.18	2.17	2.19	2.42	2.42	2.42	2.43	2.71	2.71	2.71	2.72	
Capacity	35231	35711	36727	38279	34926	35407	36423	37975	34038	34518	35535	37087	32510	32990	34006	35559	30642	31123	32139	33691	28937	29418	30434	31986	
S/T	1.00	0.97	0.83	0.69	1.00	1.00	0.84	0.69	1.00	1.00	0.86	0.72	1.00	1.00	0.88	0.74	1.00	1.00	0.76	0.61	1.00	1.00	0.82	0.67	
Evap dT	30	28	25	21	30	28	24	21	30	28	25	22	30	28	24	21	29	28	24	21	30	29	25	22	
Pr Suc	130	132	135	141	138	140	143	148	145	146	150	155	151	152	155	161	156	158	161	166	163	165	168	173	
Pr Dis	239	240	242	246	277	278	279	283	316	317	318	322	357	358	360	364	403	404	405	409	451	452	454	458	
Amps	5.7	5.6	5.6	5.7	6.4	6.4	6.4	6.5	7.3	7.3	7.3	7.4	8.3	8.3	8.3	8.3	9.4	9.4	9.3	9.4	10.6	10.6	10.6	10.7	
kW	1.58	1.58	1.57	1.59	1.76	1.76	1.76	1.77	1.96	1.96	1.96	1.97	2.18	2.18	2.18	2.19	2.43	2.43	2.42	2.44	2.72	2.72	2.71	2.73	
Capacity	36019	36499	37515	39067	35714	36195	37211	38763	34826	35307	36323	37875	33298	33778	34794	36347	31430	31911	32927	34479	29725	30206	31222	32774	
S/T	1.00	1.00	0.88	0.73	1.00	1.00	0.88	0.73	1.00	1.00	0.91	0.76	1.00	1.00	0.93	0.78	1.00	1.00	0.80	0.65	1.00	1.00	0.86	0.71	
Evap dT	28	27	23	20	28	27	23	20	29	27	23	20	28	27	23	20	28	26	23	20	29	27	24	21	
Pr Suc	133	135	138	144	141	143	146	151	148	149	153	158	153	155	158	164	159	161	164	169	166	168	171	176	
Pr Dis	242	243	245	249	279	280	282	286	318	319	321	325	360	361	363	367	405	406	408	412	454	455	456	460	
Amps	5.7	5.7	5.7	5.7	6.5	6.5	6.5	6.5	7.4	7.4	7.4	7.4	8.3	8.3	8.3	8.4	9.4	9.4	9.4	9.4	10.7	10.7	10.6	10.7	
kW	1.59	1.59	1.58	1.60	1.77	1.77	1.77	1.78	1.97	1.97	1.97	1.98	2.19	2.19	2.19	2.20	2.44	2.44	2.44	2.45	2.73	2.73	2.72	2.74	

IDB: Entering Indoor Dry Bulb Temperature
 High and low pressures are measured at the liquid and suction service valves.
 Shaded area reflects AHRl (TVA) conditions
 kW = Total system power
 Amps = outdoor unit amps (compressor + fan)

EXPANDING COOLING DATA — GLZT7CA6010A*+DMVT60DP1300A*

IDB	AIRFLOW	OUTDOOR AMBIENT TEMPERATURE																							
		65°F				75°F				85°F				95°F				105°F				115°F			
		59	63	67	71	59	63	67	71	59	63	67	71	59	63	67	71	59	63	67	71	59	63	67	71
70	Capacity	58285	59104	60836	-	57766	58585	60317	-	56252	57071	58803	-	53646	54465	56198	-	50462	51281	53014	-	47555	48375	50107	-
	S/T	0.63	0.55	0.42	-	0.63	0.56	0.42	-	0.66	0.58	0.45	-	0.68	0.60	0.47	-	1.00	0.62	0.49	-	1.00	0.67	0.54	-
	Evap dT	19	17	14	-	19	17	14	-	19	17	14	-	19	17	14	-	19	17	14	-	20	18	15	-
	Pr Suc	120	122	125	-	127	129	132	-	134	135	138	-	139	141	144	-	144	146	149	-	151	152	155	-
	Pr Dis	256	257	259	-	296	297	299	-	338	339	341	-	384	385	387	-	433	434	436	-	485	486	488	-
Amps	11.4	11.4	11.4	-	13.1	13.1	13.1	-	15.0	14.9	14.9	-	17.0	17.0	16.9	-	19.2	19.2	19.2	-	21.9	21.8	21.8	-	
kW	3.31	3.31	3.30	-	3.69	3.69	3.68	-	4.12	4.12	4.11	-	4.58	4.58	4.57	-	5.10	5.10	5.09	-	5.71	5.70	5.70	-	
70	Capacity	58753	59572	61304	-	58234	59053	60785	-	56719	57538	59271	-	54114	54933	56665	-	50930	51749	53481	-	48023	48842	50575	-
	S/T	0.66	0.58	0.45	-	0.66	0.59	0.45	-	0.69	0.61	0.48	-	0.71	0.63	0.50	-	1.00	0.65	0.52	-	1.00	0.71	0.57	-
	Evap dT	18	17	13	-	18	17	13	-	19	17	13	-	18	17	13	-	18	16	13	-	19	17	14	-
	Pr Suc	121	123	126	-	128	130	133	-	135	136	139	-	140	142	145	-	145	147	150	-	152	153	156	-
	Pr Dis	257	258	260	-	297	299	300	-	340	341	343	-	385	386	388	-	434	435	437	-	486	487	489	-
Amps	11.5	11.5	11.4	-	13.1	13.1	13.1	-	15.0	15.0	15.0	-	17.0	17.0	17.0	-	19.3	19.3	19.2	-	21.9	21.9	21.9	-	
kW	3.32	3.32	3.31	-	3.70	3.70	3.69	-	4.13	4.13	4.12	-	4.59	4.59	4.58	-	5.11	5.11	5.10	-	5.72	5.71	5.71	-	
2250	Capacity	60219	61038	62770	-	59699	60519	62251	-	58185	59004	60737	-	55580	56399	58131	-	52396	53215	54947	-	49489	50308	52040	-
	S/T	0.70	0.62	0.49	-	0.71	0.63	0.50	-	0.73	0.66	0.52	-	1.00	0.67	0.54	-	1.00	0.70	0.56	-	1.00	0.75	0.61	-
	Evap dT	17	15	12	-	17	15	12	-	17	15	12	-	17	15	12	-	17	15	12	-	18	16	13	-
	Pr Suc	124	126	129	-	131	133	136	-	138	139	142	-	143	145	148	-	148	150	153	-	155	157	160	-
	Pr Dis	260	262	263	-	301	302	304	-	343	344	346	-	388	389	391	-	437	438	440	-	489	491	492	-
Amps	11.6	11.6	11.5	-	13.3	13.2	13.2	-	15.1	15.1	15.1	-	17.1	17.1	17.1	-	19.4	19.4	19.3	-	22.0	22.0	22.0	-	
kW	3.34	3.34	3.34	-	3.73	3.72	3.72	-	4.16	4.15	4.15	-	4.62	4.62	4.61	-	5.14	5.13	5.13	-	5.74	5.74	5.73	-	
75	Capacity	58319	59138	60870	63516	57800	58619	60351	62997	56285	57104	58837	61483	53680	54499	56232	58878	50496	51315	53047	55694	47589	48408	50141	52787
	S/T	0.75	0.68	0.54	0.40	0.76	0.68	0.55	0.41	1.00	0.71	0.58	0.43	1.00	0.73	0.59	0.45	1.00	0.75	0.62	0.48	1.00	0.80	0.67	0.53
	Evap dT	23	21	18	14	23	21	18	14	23	21	18	15	23	21	18	14	23	21	18	14	24	22	19	15
	Pr Suc	120	122	125	130	127	129	132	137	134	135	138	143	139	141	144	149	144	146	149	154	151	152	155	161
	Pr Dis	256	257	259	264	296	298	299	304	339	340	341	346	384	385	387	391	433	434	436	440	485	486	488	493
Amps	11.4	11.4	11.4	11.5	13.1	13.1	13.0	13.2	14.9	14.9	14.9	15.0	17.0	16.9	16.9	17.0	19.2	19.2	19.2	19.3	21.8	21.8	21.8	21.9	
kW	3.31	3.30	3.30	3.33	3.69	3.69	3.68	3.71	4.12	4.11	4.11	4.14	4.58	4.58	4.57	4.60	5.10	5.09	5.09	5.12	5.70	5.70	5.69	5.72	
75	Capacity	58787	59606	61338	63984	58267	59087	60819	63465	56753	57572	59305	61951	54148	54967	56699	59345	50964	51783	53515	56161	48057	48876	50608	53255
	S/T	0.79	0.71	0.58	0.44	0.79	0.72	0.58	0.44	1.00	0.74	0.61	0.47	1.00	0.76	0.63	0.49	1.00	0.78	0.65	0.51	1.00	0.83	0.70	0.56
	Evap dT	22	21	17	14	22	21	17	14	23	21	17	14	22	21	17	14	22	20	17	13	23	21	18	15
	Pr Suc	121	123	126	131	128	130	133	138	135	136	139	144	140	142	145	150	145	147	150	155	152	153	157	162
	Pr Dis	257	259	260	265	298	299	301	305	340	341	343	347	385	386	388	393	434	435	437	442	486	488	489	494
Amps	11.5	11.5	11.4	11.6	13.1	13.1	13.1	13.2	15.0	15.0	15.0	15.1	17.0	17.0	17.0	17.1	19.3	19.2	19.2	19.3	21.9	21.9	21.9	22.0	
kW	3.32	3.31	3.31	3.34	3.70	3.70	3.69	3.72	4.13	4.13	4.12	4.15	4.59	4.59	4.58	4.61	5.11	5.11	5.10	5.13	5.71	5.71	5.71	5.73	
2250	Capacity	60252	61071	62804	65450	59733	60552	62285	64931	58219	59038	60770	63417	55614	56433	58165	60811	52430	53249	54981	57627	49523	50342	52074	54720
	S/T	0.83	0.75	0.62	0.48	0.83	0.76	0.62	0.48	1.00	0.78	0.65	0.51	1.00	0.80	0.67	0.53	1.00	0.82	0.69	0.55	1.00	1.00	0.74	0.60
	Evap dT	21	19	16	12	21	19	16	12	21	19	16	13	21	19	16	12	21	19	16	12	22	20	17	13
	Pr Suc	124	126	129	134	131	133	136	141	138	139	142	147	143	145	148	153	148	150	153	158	155	157	160	165
	Pr Dis	261	262	264	268	301	302	304	308	343	344	346	350	388	390	391	396	437	439	440	445	490	491	493	497
Amps	11.6	11.6	11.5	11.7	13.2	13.2	13.2	13.3	15.1	15.1	15.1	15.2	17.1	17.1	17.1	17.2	19.4	19.4	19.3	19.5	22.0	22.0	22.0	22.1	
kW	3.34	3.34	3.33	3.36	3.73	3.72	3.72	3.75	4.15	4.15	4.14	4.17	4.62	4.61	4.61	4.64	5.13	5.13	5.12	5.15	5.74	5.74	5.73	5.76	

Shaded area reflects ACCA (TVA) conditions
 kW = Total system power
 Amps = outdoor unit amps (compressor + fan)

EXPANDING COOLING DATA — GLZT7CA6010A*+DMVT60DP1300A* (CONT.)

IDB	AIRFLOW	OUTDOOR AMBIENT TEMPERATURE																							
		65°F				75°F				85°F				95°F				105°F				115°F			
		59	63	67	71	59	63	67	71	59	63	67	71	59	63	67	71	59	63	67	71	59	63	67	71
80	Capacity	58619	59438	61171	63817	58100	58919	60652	63298	56586	57405	59137	61783	53981	54800	56532	59178	50796	51616	53348	55994	47890	48709	50441	53087
	S/T	0.88	0.80	0.67	0.53	1.00	0.81	0.67	0.53	1.00	0.83	0.70	0.56	1.00	0.85	0.72	0.58	1.00	1.00	0.74	0.60	1.00	1.00	0.79	0.65
	Evap dT	27	25	22	18	27	25	22	18	27	25	22	19	27	25	22	18	27	25	22	18	28	26	23	19
	Pr Suc	121	122	125	130	128	129	132	137	134	136	139	144	140	141	144	149	145	146	149	154	151	153	156	161
	Pr Dis	257	258	260	264	297	298	300	304	339	340	342	346	384	386	387	392	433	435	436	441	486	487	489	493
	Amps	11.4	11.4	11.4	11.5	13.1	13.1	13.1	13.2	15.0	14.9	14.9	15.0	17.0	17.0	16.9	17.1	19.2	19.2	19.2	19.3	21.9	21.9	21.8	21.9
kW	3.31	3.31	3.30	3.33	3.69	3.69	3.68	3.71	4.12	4.12	4.11	4.14	4.58	4.58	4.57	4.60	5.10	5.10	5.09	5.12	5.71	5.70	5.70	5.73	
1750	Capacity	59087	59906	61638	64285	58568	59387	61119	63765	57054	57873	59605	62251	54448	55267	57000	59646	51264	52083	53816	56462	48357	49176	50909	53555
	S/T	0.91	0.83	0.70	0.56	1.00	0.84	0.71	0.57	1.00	0.86	0.73	0.59	1.00	0.88	0.75	0.61	1.00	1.00	0.77	0.63	1.00	1.00	0.82	0.68
	Evap dT	26	25	21	18	27	25	22	18	27	25	22	18	27	25	22	18	27	25	21	18	28	26	23	19
	Pr Suc	122	123	126	131	129	130	133	139	135	137	140	145	141	142	145	150	146	147	150	156	153	154	157	162
	Pr Dis	258	259	261	265	298	299	301	306	340	341	343	348	386	387	389	393	435	436	438	442	487	488	490	494
	Amps	11.5	11.5	11.4	11.6	13.1	13.1	13.1	13.2	15.0	15.0	15.0	15.1	17.0	17.0	17.0	17.1	19.3	19.3	19.2	19.4	21.9	21.9	21.9	22.0
kW	3.32	3.32	3.31	3.34	3.70	3.70	3.69	3.72	4.13	4.13	4.12	4.15	4.59	4.59	4.58	4.61	5.11	5.11	5.10	5.13	5.72	5.71	5.71	5.74	
2250	Capacity	60553	61372	63104	65750	60034	60853	62585	65231	58519	59338	61071	63717	55914	56733	58466	61112	52730	53549	55281	57928	49823	50642	52375	55021
	S/T	1.00	0.88	0.74	0.60	1.00	0.88	0.75	0.61	1.00	0.91	0.77	0.63	1.00	0.93	0.79	0.65	1.00	1.00	0.81	0.67	1.00	1.00	0.86	0.72
	Evap dT	25	23	20	16	25	23	20	16	25	23	20	17	25	23	20	16	25	23	20	16	26	24	21	18
	Pr Suc	125	126	129	134	132	133	136	142	138	140	143	148	144	145	148	153	149	150	153	159	156	157	160	165
	Pr Dis	261	262	264	268	301	302	304	309	344	345	346	351	389	390	392	396	438	439	441	445	490	491	493	497
	Amps	11.6	11.6	11.5	11.7	13.3	13.2	13.2	13.3	15.1	15.1	15.1	15.2	17.1	17.1	17.1	17.2	19.4	19.4	19.3	19.5	22.0	22.0	22.0	22.1
kW	3.34	3.34	3.33	3.36	3.73	3.72	3.72	3.75	4.16	4.15	4.15	4.17	4.62	4.61	4.61	4.64	5.13	5.13	5.13	5.15	5.74	5.74	5.74	5.76	

1750	Capacity	59596	60415	62148	64794	59077	59896	61629	64275	57563	58382	60114	62761	54958	55777	57509	60155	51774	52593	54325	56971	48867	49686	51418	54064
	S/T	1.00	0.90	0.77	0.63	1.00	0.91	0.77	0.63	1.00	1.00	0.80	0.66	1.00	1.00	0.82	0.68	1.00	1.00	0.84	0.70	1.00	1.00	0.89	0.75
	Evap dT	31	29	25	22	31	29	25	22	31	29	26	22	30	29	25	22	30	28	25	22	31	30	26	23
	Pr Suc	122	124	127	132	130	131	134	139	136	137	141	146	141	143	146	151	147	148	151	156	153	155	158	163
	Pr Dis	258	259	261	265	298	299	301	305	340	341	343	348	386	387	389	393	435	436	438	442	487	488	490	494
	Amps	11.5	11.5	11.4	11.6	13.1	13.1	13.1	13.2	15.0	15.0	14.9	15.1	17.0	17.0	17.0	17.1	19.2	19.2	19.2	19.3	21.9	21.9	21.8	22.0
kW	3.32	3.31	3.31	3.34	3.70	3.70	3.69	3.72	4.13	4.12	4.12	4.15	4.59	4.59	4.58	4.61	5.11	5.10	5.10	5.13	5.71	5.71	5.71	5.73	
1890	Capacity	60064	60883	62616	65262	59545	60364	62096	64743	58031	58850	60582	63228	55425	56244	57977	60623	52241	53060	54793	57439	49335	50154	51886	54532
	S/T	1.00	0.93	0.80	0.66	1.00	0.94	0.81	0.67	1.00	1.00	0.83	0.69	1.00	1.00	0.85	0.71	1.00	1.00	0.87	0.73	1.00	1.00	1.00	0.78
	Evap dT	30	28	25	21	30	28	25	21	30	28	25	21	30	28	25	21	30	28	24	21	31	29	26	22
	Pr Suc	123	125	128	133	131	132	135	140	137	139	142	147	142	144	147	152	148	149	152	157	154	156	159	164
	Pr Dis	259	260	262	266	299	300	302	307	342	343	344	349	387	388	390	394	436	437	439	443	488	489	491	495
	Amps	11.5	11.5	11.5	11.6	13.2	13.2	13.1	13.3	15.0	15.0	15.0	15.1	17.1	17.0	17.0	17.1	19.3	19.3	19.3	19.4	21.9	21.9	21.9	22.0
kW	3.33	3.32	3.32	3.35	3.71	3.71	3.70	3.73	4.14	4.13	4.13	4.16	4.60	4.60	4.59	4.62	5.12	5.11	5.11	5.14	5.72	5.72	5.72	5.74	
2250	Capacity	61530	62349	64081	66728	61011	61830	63562	66208	59497	60316	62048	64694	56891	57710	59443	62089	53707	54526	56259	58905	50800	51619	53352	55998
	S/T	1.00	0.98	0.84	0.70	1.00	0.98	0.85	0.71	1.00	1.00	0.87	0.73	1.00	1.00	0.89	0.75	1.00	1.00	0.91	0.77	1.00	1.00	1.00	0.82
	Evap dT	29	27	23	20	29	27	23	20	29	27	24	20	29	27	23	20	28	26	23	20	29	28	24	21
	Pr Suc	126	128	131	136	134	135	138	143	140	142	145	150	145	147	150	155	151	152	155	160	157	159	162	167
	Pr Dis	262	263	265	270	303	304	305	310	345	346	348	352	390	391	393	397	439	440	442	446	491	492	494	499
	Amps	11.6	11.6	11.6	11.7	13.3	13.3	13.2	13.4	15.1	15.1	15.1	15.2	17.2	17.1	17.1	17.2	19.4	19.4	19.4	19.5	22.0	22.0	22.0	22.1
kW	3.35	3.35	3.34	3.37	3.73	3.73	3.73	3.75	4.16	4.16	4.15	4.18	4.63	4.62	4.62	4.64	5.14	5.14	5.13	5.16	5.75	5.75	5.75	5.77	

IDB: Entering Indoor Dry Bulb Temperature
 High and low pressures are measured at the liquid and suction service valves.
 Shaded area reflects AHRI (TVA) conditions
 kW = Total system power
 Amps = outdoor unit amps (compressor + fan)

EXPANDING COOLING DATA — GLZT7CA4810A*+DMVT60DP1300A* (70%)

IDB	AIRFLOW	OUTDOOR AMBIENT TEMPERATURE																							
		65°F				75°F				85°F				95°F				105°F				115°F			
		59	63	67	71	59	63	67	71	59	63	67	71	59	63	67	71	59	63	67	71	59	63	67	71
70	Capacity	41907	42496	43741	-	41534	42123	43368	-	40445	41034	42279	-	38572	39161	40406	-	36282	36871	38117	-	34192	34781	36027	-
	S/T	0.64	0.57	0.43	-	0.65	0.57	0.43	-	0.67	0.60	0.46	-	0.69	0.62	0.48	-	1.00	0.64	0.50	-	1.00	0.69	0.55	-
	Evap dT	18	17	13	-	18	17	13	-	19	17	14	-	18	17	13	-	18	16	13	-	19	17	14	-
	Pr Suc	123	125	128	-	131	132	135	-	137	139	142	-	143	144	148	-	148	150	153	-	155	157	160	-
	Pr Dis	123	246	247	-	283	284	286	-	323	325	326	-	367	368	370	-	414	415	416	-	464	465	466	-
	Amps	7.2	7.2	7.2	-	8.2	8.2	8.2	-	9.4	9.4	9.4	-	10.7	10.7	10.6	-	12.1	12.1	12.1	-	13.7	13.7	13.7	-
	kW	2.08	2.08	2.08	-	2.32	2.32	2.32	-	2.59	2.59	2.59	-	2.88	2.88	2.88	-	3.21	3.21	3.20	-	3.59	3.59	3.58	-
	Capacity	42243	42832	44078	-	41870	42459	43704	-	40781	41370	42616	-	38908	39497	40742	-	36619	37208	38453	-	34529	35118	36363	-
	S/T	0.68	0.60	0.46	-	0.68	0.60	0.47	-	0.71	0.63	0.49	-	1.00	0.65	0.51	-	1.00	0.67	0.53	-	1.00	0.72	0.59	-
	Evap dT	18	16	13	-	18	16	13	-	18	16	13	-	18	16	13	-	17	16	12	-	19	17	14	-
Pr Suc	124	126	129	-	132	133	137	-	138	140	143	-	144	146	149	-	149	151	154	-	156	158	161	-	
Pr Dis	246	247	249	-	284	285	287	-	325	326	327	-	368	369	371	-	415	416	418	-	465	466	468	-	
Amps	7.2	7.2	7.2	-	8.3	8.3	8.2	-	9.4	9.4	9.4	-	10.7	10.7	10.7	-	12.1	12.1	12.1	-	13.8	13.8	13.8	-	
kW	2.09	2.09	2.08	-	2.33	2.33	2.32	-	2.60	2.60	2.59	-	2.89	2.89	2.88	-	3.21	3.21	3.21	-	3.60	3.59	3.59	-	
Capacity	43297	43886	45132	-	42924	43513	44758	-	41835	42424	43670	-	39962	40551	41796	-	37673	38261	39507	-	35583	36172	37417	-	
S/T	0.72	0.64	0.50	-	0.73	0.65	0.51	-	0.75	0.67	0.54	-	1.00	0.69	0.56	-	1.00	0.72	0.58	-	1.00	0.77	0.63	-	
Evap dT	16	15	11	-	16	15	11	-	17	15	12	-	16	15	11	-	16	14	11	-	17	16	12	-	
Pr Suc	128	129	132	-	135	137	140	-	142	143	146	-	147	149	152	-	153	154	157	-	159	161	164	-	
Pr Dis	249	250	252	-	287	289	290	-	328	329	331	-	371	372	374	-	418	419	421	-	468	469	471	-	
Amps	7.3	7.3	7.3	-	8.3	8.3	8.3	-	9.5	9.5	9.5	-	10.8	10.8	10.7	-	12.2	12.2	12.2	-	13.8	13.8	13.8	-	
kW	2.10	2.10	2.10	-	2.34	2.34	2.34	-	2.61	2.61	2.61	-	2.90	2.90	2.90	-	3.23	3.23	3.22	-	3.61	3.61	3.61	-	

75	Capacity	41931	42520	43766	45668	41558	42147	43392	45295	40469	41058	42304	44206	38596	39185	40430	42333	36307	36896	38141	40044	34217	34806	36051	37954
	S/T	0.77	0.70	0.56	0.41	0.78	0.70	0.57	0.42	1.00	0.73	0.59	0.45	1.00	0.75	0.61	0.47	1.00	0.77	0.63	0.49	1.00	1.00	0.69	0.54
	Evap dT	22	20	17	14	22	20	17	14	22	21	17	14	22	20	17	14	22	20	17	14	23	21	18	15
	Pr Suc	123	125	128	133	131	132	136	141	137	139	142	147	143	144	148	153	148	150	153	158	155	157	160	165
	Pr Dis	245	246	248	252	283	284	286	290	324	325	326	331	367	368	370	374	414	415	417	421	464	465	467	471
	Amps	7.2	7.2	7.2	7.2	8.2	8.2	8.2	8.3	9.4	9.4	9.4	9.5	10.7	10.7	10.6	10.7	12.1	12.1	12.1	12.1	13.7	13.7	13.7	13.8
	kW	2.08	2.08	2.07	2.09	2.32	2.32	2.31	2.33	2.59	2.59	2.58	2.60	2.88	2.88	2.87	2.89	3.21	3.20	3.20	3.22	3.59	3.59	3.58	3.60
	Capacity	42268	42856	44102	46005	41894	42483	43729	45631	40806	41394	42640	44543	38932	39521	40767	42669	36643	37232	38477	40380	34553	35142	36387	38290
	S/T	0.81	0.73	0.59	0.45	0.81	0.74	0.60	0.45	1.00	0.76	0.62	0.48	1.00	0.78	0.64	0.50	1.00	0.80	0.67	0.52	1.00	1.00	0.72	0.57
	Evap dT	22	20	17	13	22	20	17	13	22	20	17	13	22	20	17	13	21	20	16	13	22	21	17	14
Pr Suc	125	126	129	134	132	133	137	142	139	140	143	148	144	146	149	154	149	151	154	159	156	158	161	166	
Pr Dis	246	247	249	253	285	286	287	292	325	326	328	332	368	369	371	375	415	416	418	422	465	466	468	472	
Amps	7.2	7.2	7.2	7.3	8.3	8.3	8.2	8.3	9.4	9.4	9.4	9.5	10.7	10.7	10.8	10.8	12.1	12.1	12.1	12.2	13.8	13.8	13.7	13.8	
kW	2.09	2.09	2.08	2.10	2.33	2.33	2.32	2.34	2.60	2.59	2.59	2.61	2.89	2.89	2.88	2.90	3.21	3.21	3.21	3.23	3.59	3.59	3.59	3.61	
Capacity	43321	43910	45156	47059	42948	43537	44783	46685	41859	42448	43694	45597	39986	40575	41821	43723	37697	38286	39531	41434	35607	36196	37441	39344	
S/T	0.85	0.77	0.63	0.49	1.00	0.78	0.64	0.50	1.00	0.80	0.67	0.52	1.00	0.82	0.69	0.54	1.00	0.85	0.71	0.56	1.00	1.00	0.76	0.62	
Evap dT	20	19	15	12	20	19	15	12	21	19	16	12	20	19	15	12	20	18	15	12	21	19	16	13	
Pr Suc	128	129	132	138	135	137	140	145	142	143	146	152	147	149	152	157	153	154	157	162	159	161	164	169	
Pr Dis	249	250	252	256	288	289	290	295	328	329	331	335	371	372	374	378	418	419	421	425	468	469	471	475	
Amps	7.3	7.3	7.3	7.3	8.3	8.3	8.3	8.4	9.5	9.5	9.5	9.6	10.8	10.8	10.7	10.8	12.2	12.2	12.2	12.2	13.8	13.8	13.8	13.9	
kW	2.10	2.10	2.10	2.11	2.34	2.34	2.34	2.36	2.61	2.61	2.61	2.62	2.90	2.90	2.90	2.92	3.23	3.23	3.23	3.24	3.61	3.61	3.60	3.62	

IDB: Entering Indoor Dry Bulb Temperature
 High and low pressures are measured at the liquid and suction service valves.
 Shaded area reflects ACCA (TVA) conditions
 kW = Total system power
 Amps = outdoor unit amps (compressor + fan)

EXPANDING COOLING DATA — GLZT7CA4810A*+DMVT60DP1300A* (70%) (CONT.)

IDB	AIRFLOW	OUTDOOR AMBIENT TEMPERATURE																							
		65°F				75°F				85°F				95°F				105°F				115°F			
		59	63	67	71	59	63	67	71	59	63	67	71	59	63	67	71	59	63	67	71	59	63	67	71
80	Capacity	42147	42736	43982	45884	41774	42363	43608	45511	40685	41274	42520	44422	38812	39401	40646	42549	36523	37112	38357	40260	34433	35022	36267	38170
	S/T	1.00	0.82	0.69	0.54	1.00	0.83	0.69	0.55	1.00	0.86	0.72	0.57	1.00	0.88	0.74	0.59	1.00	1.00	0.76	0.62	1.00	1.00	0.81	0.67
	Evap dT	26	24	21	18	26	24	21	18	26	25	21	18	26	24	21	18	26	24	21	17	27	25	22	18
	Pr Suc	124	125	129	134	131	133	136	141	138	139	143	148	143	145	148	153	149	150	154	159	156	157	160	166
	Pr Dis	245	246	248	252	284	285	287	291	324	325	327	331	368	369	370	375	414	415	417	421	464	465	467	471
	Amps	7.2	7.2	7.2	7.2	8.2	8.2	8.2	8.3	9.4	9.4	9.4	9.5	10.7	10.7	10.6	10.7	12.1	12.1	12.1	12.1	13.7	13.7	13.7	13.8
	kW	2.08	2.08	2.08	2.09	2.32	2.32	2.32	2.33	2.59	2.59	2.58	2.60	2.88	2.88	2.88	2.89	3.21	3.21	3.20	3.22	3.59	3.59	3.59	3.60
80	Capacity	42484	43072	44318	46221	42110	42699	43945	45847	41022	41610	42856	44759	39148	39737	40983	42885	36859	37448	38693	40596	34769	35358	36603	38506
	S/T	1.00	0.86	0.72	0.57	1.00	0.86	0.73	0.58	1.00	0.89	0.75	0.61	1.00	1.00	0.77	0.63	1.00	1.00	0.79	0.65	1.00	1.00	0.85	0.70
	Evap dT	25	24	20	17	25	24	20	17	26	24	21	17	25	24	20	17	25	23	20	17	26	25	21	18
	Pr Suc	128	130	133	138	133	134	137	142	139	141	144	149	145	146	149	154	150	152	155	160	157	158	161	167
	Pr Dis	247	248	249	254	285	286	288	292	325	326	328	332	369	370	372	376	416	417	418	423	465	467	468	473
	Amps	7.2	7.2	7.2	7.3	8.3	8.3	8.3	8.3	9.4	9.4	9.4	9.5	10.7	10.7	10.7	10.8	12.1	12.1	12.1	12.2	13.8	13.8	13.8	13.8
	kW	2.09	2.09	2.08	2.10	2.33	2.33	2.32	2.34	2.60	2.60	2.59	2.61	2.89	2.89	2.88	2.90	3.21	3.21	3.21	3.23	3.60	3.59	3.59	3.61
80	Capacity	43537	44126	45372	47275	43164	43753	44959	46901	42075	42664	43910	45813	40202	40791	42037	43939	37913	38502	39747	41650	35823	36412	37657	39560
	S/T	1.00	0.90	0.76	0.62	1.00	0.91	0.77	0.62	1.00	0.93	0.79	0.65	1.00	1.00	0.81	0.67	1.00	1.00	0.84	0.69	1.00	1.00	0.89	0.74
	Evap dT	24	22	19	16	24	22	19	16	24	23	19	16	24	22	19	16	24	22	19	16	25	23	20	17
	Pr Suc	128	130	133	138	136	137	140	146	142	144	147	152	148	149	152	158	153	155	158	163	160	161	165	170
	Pr Dis	250	251	252	257	288	289	291	295	328	329	331	335	372	373	375	379	419	420	421	426	469	470	471	476
	Amps	7.3	7.3	7.3	7.3	8.3	8.3	8.3	8.4	9.5	9.5	9.5	9.6	10.8	10.8	10.7	10.8	12.2	12.2	12.2	12.2	13.8	13.8	13.8	13.8
	kW	2.10	2.10	2.10	2.12	2.34	2.34	2.34	2.36	2.61	2.61	2.61	2.63	2.90	2.90	2.90	2.92	3.23	3.23	3.23	3.24	3.61	3.61	3.61	3.62

85	Capacity	42850	43439	44684	46587	42477	43065	44311	46214	41388	41977	43222	45125	39515	40103	41349	43252	37225	37814	39060	40962	35135	35724	36970	38872
	S/T	1.00	0.93	0.79	0.64	1.00	0.93	0.80	0.65	1.00	1.00	0.82	0.68	1.00	1.00	0.84	0.70	1.00	1.00	0.86	0.72	1.00	1.00	1.00	0.77
	Evap dT	29	28	24	21	29	28	24	21	30	28	25	21	29	28	24	21	29	27	24	21	30	29	25	22
	Pr Suc	126	127	130	136	133	135	138	143	140	141	144	150	145	147	150	155	151	152	155	161	158	159	162	167
	Pr Dis	247	248	249	254	285	286	288	292	325	326	328	332	369	370	371	376	415	417	418	423	465	466	468	472
	Amps	7.2	7.2	7.2	7.3	8.3	8.3	8.2	8.3	9.4	9.4	9.4	9.5	10.7	10.7	10.7	10.7	12.1	12.1	12.1	12.2	13.8	13.8	13.7	13.8
	kW	2.09	2.08	2.08	2.10	2.33	2.32	2.32	2.34	2.60	2.59	2.59	2.61	2.89	2.88	2.88	2.90	3.21	3.21	3.21	3.22	3.59	3.59	3.59	3.61
85	Capacity	43186	43775	45021	46923	42813	43402	44647	46550	41724	42313	43559	45461	39851	40440	41685	43588	37562	38150	39396	41299	35472	36060	37306	39209
	S/T	1.00	0.96	0.82	0.68	1.00	1.00	0.83	0.68	1.00	1.00	0.85	0.71	1.00	1.00	0.87	0.73	1.00	1.00	0.90	0.75	1.00	1.00	1.00	0.80
	Evap dT	29	27	24	21	29	27	24	20	29	27	24	21	29	27	24	20	29	27	24	20	30	28	25	21
	Pr Suc	127	128	132	137	134	136	139	144	141	142	146	151	146	148	151	156	152	153	156	162	159	160	163	168
	Pr Dis	248	249	250	255	286	287	289	293	326	328	329	334	370	371	373	377	417	418	419	424	467	468	469	474
	Amps	7.2	7.2	7.2	7.3	8.3	8.3	8.3	8.3	9.5	9.5	9.4	9.5	10.7	10.7	10.7	10.8	12.1	12.1	12.1	12.2	13.8	13.8	13.8	13.9
	kW	2.09	2.09	2.09	2.11	2.33	2.33	2.33	2.35	2.60	2.60	2.60	2.62	2.89	2.89	2.89	2.91	3.22	3.22	3.22	3.23	3.60	3.60	3.60	3.61
85	Capacity	44240	44829	46074	47977	43867	44456	45701	47604	42778	43367	44612	46515	40905	41494	42739	44642	38615	39204	40450	42353	36525	37114	38360	40263
	S/T	1.00	1.00	0.86	0.72	1.00	1.00	0.87	0.73	1.00	1.00	0.90	0.75	1.00	1.00	0.92	0.77	1.00	1.00	1.00	0.79	1.00	1.00	1.00	0.85
	Evap dT	28	26	23	19	28	26	23	19	28	26	23	19	28	26	23	19	27	26	22	19	28	27	23	20
	Pr Suc	130	132	135	140	138	139	142	147	144	146	149	154	150	151	154	159	155	157	160	165	162	163	166	172
	Pr Dis	251	252	254	258	289	290	292	296	330	331	332	337	373	374	376	380	420	421	423	427	470	471	472	477
	Amps	7.3	7.3	7.3	7.4	8.4	8.3	8.3	8.4	9.5	9.5	9.5	9.6	10.8	10.8	10.8	10.8	12.2	12.2	12.2	12.3	13.9	13.9	13.8	13.9
	kW	2.11	2.11	2.10	2.12	2.35	2.35	2.34	2.36	2.62	2.62	2.62	2.63	2.91	2.91	2.90	2.92	3.23	3.23	3.23	3.25	3.62	3.61	3.61	3.63

IDB: Entering Indoor Dry Bulb Temperature
 High and low pressures are measured at the liquid and suction service valves.
 Shaded area reflects AHRI (TVA) conditions
 kW = Total system power
 Amps = outdoor unit amps (compressor + fan)

HEATING DATA - HIGH STAGE

GLZT7CA2410A*+DMVT30BP1300A*

100 % CAPACITY

	OUTDOOR AMBIENT TEMPERATURE																
	65	60	55	50	47	45	40	35	30	25	20	17	15	10	5	0	-5
MBh	30.20	28.30	26.42	24.58	23.40	22.54	20.34	18.30	16.63	15.39	14.49	14.00	13.37	11.81	10.24	8.67	7.11
T/R	34.48	32.62	30.76	28.90	27.78	26.76	24.15	21.72	19.74	18.27	17.20	16.62	15.88	14.02	12.16	10.30	8.44
KW	1.76	1.74	1.71	1.68	1.67	1.66	1.63	1.60	1.58	1.55	1.52	1.51	1.50	1.47	1.44	1.42	1.39
AMPS	6.4	6.3	6.2	6.1	6.0	6.0	5.9	5.7	5.6	5.5	5.4	5.3	5.3	5.2	5.0	4.9	4.8
COP	5.02	4.77	4.53	4.28	4.11	3.98	3.65	3.34	3.09	2.91	2.78	2.72	2.62	2.35	2.08	1.79	1.50
Hi PR	404	391	378	365	357	352	339	325	312	299	286	278	273	260	247	233	220
LO PR	149	140	131	122	116	112	103	94	84	75	66	60	56	47	38	29	19

GLZT7CA3610A*+DMVT42CP1300A*

100 % CAPACITY

	OUTDOOR AMBIENT TEMPERATURE																
	65	60	55	50	47	45	40	35	30	25	20	17	15	10	5	0	-5
MBh	44.1	41.4	38.7	36.1	34.4	33.2	30.1	27.1	24.7	23.0	21.7	21.0	20.1	17.9	15.6	13.4	11.2
T/R	33.0	31.3	29.5	27.8	26.8	25.8	23.4	21.1	19.2	17.9	16.9	16.3	15.6	13.9	12.2	10.4	8.7
KW	2.7	2.6	2.6	2.6	2.5	2.5	2.5	2.5	2.4	2.4	2.4	2.3	2.3	2.3	2.3	2.2	2.2
AMPS	9.7	9.5	9.4	9.2	9.1	9.1	8.9	8.8	8.6	8.5	8.3	8.2	8.2	8.0	7.9	7.8	7.6
COP	4.87	4.63	4.39	4.14	3.98	3.86	3.54	3.24	3.00	2.82	2.70	2.64	2.54	2.29	2.04	1.77	1.50
Hi PR	404	391	378	365	357	352	339	325	312	299	286	278	273	260	247	233	220
LO PR	149	140	131	122	116	112	103	94	84	75	66	60	56	47	38	29	19

GLZT7CA4810A*+DMVT60DP1300A*

100 % CAPACITY

	OUTDOOR AMBIENT TEMPERATURE																
	65	60	55	50	47	45	40	35	30	25	20	17	15	10	5	0	-5
MBh	61.4	57.8	54.2	50.8	48.5	46.9	42.9	39.0	35.8	33.5	31.9	31.0	29.8	26.9	24.0	21.1	18.2
T/R	35.7	33.9	32.2	30.4	29.4	28.4	26.0	23.6	21.7	20.3	19.3	18.8	18.1	16.3	14.5	12.8	11.0
KW	3.7	3.7	3.6	3.6	3.6	3.5	3.5	3.5	3.4	3.4	3.3	3.3	3.3	3.2	3.2	3.2	3.1
AMPS	13.7	13.5	13.3	13.1	13.0	13.0	12.8	12.6	12.4	12.2	12.0	11.9	11.9	11.7	11.5	11.3	11.1
COP	4.86	4.62	4.39	4.16	4.00	3.88	3.60	3.31	3.08	2.92	2.81	2.75	2.66	2.43	2.20	1.95	1.71
Hi PR	443	428	414	400	391	385	371	356	342	328	313	305	299	284	270	256	241
LO PR	143	134	125	116	111	107	99	90	81	72	63	58	54	45	36	27	18

GLZT7CA6010A*+DMVT60DP1300A*

100 % CAPACITY

	OUTDOOR AMBIENT TEMPERATURE																
	65	60	55	50	47	45	40	35	30	25	20	17	15	10	5	0	-5
MBh	72.8	68.7	64.6	60.6	58.0	56.1	51.6	47.0	43.5	40.9	39.0	38.0	36.7	33.3	30.0	26.7	23.3
T/R	34.3	32.7	31.0	29.4	28.4	27.6	25.3	23.1	21.3	20.0	19.1	18.6	18.0	16.3	14.7	13.1	11.4
KW	4.5	4.4	4.4	4.3	4.3	4.3	4.2	4.2	4.1	4.1	4.0	4.0	4.0	3.9	3.9	3.8	3.8
AMPS	16.6	16.3	16.1	15.9	15.8	15.7	15.4	15.2	15.0	14.8	14.6	14.4	14.3	14.1	13.9	13.7	13.4
COP	4.74	4.52	4.31	4.09	3.94	3.83	3.57	3.29	3.08	2.93	2.83	2.78	2.70	2.48	2.26	2.04	1.81
Hi PR	404	391	378	365	357	352	339	325	312	299	286	278	273	260	247	233	220
LO PR	137	128	120	111	106	103	94	86	77	69	60	55	52	43	35	26	18

Calculations are based on nominal CFM and 70 °F indoor dry bulb.

Amps = Outdoor unit amps (comp.+fan)

Note: Shaded area is AHRI Rating Conditions at 47°F outdoor ambient temperature

kW = Total system power

GLZT7CA2410A*+DMVT30BP1300A*

70 % CAPACITY

	OUTDOOR AMBIENT TEMPERATURE																
	65	60	55	50	47	45	40	35	30	25	20	17	15	10	5	0	-5
MBh	22.4	20.9	19.4	17.9	16.9	16.1	14.3	12.6	11.2	10.1	9.4	8.9	8.4	7.1	5.8	4.4	3.1
T/R	38.7	36.3	34.0	31.6	30.2	28.8	25.5	22.4	20.0	18.1	16.7	16.0	15.0	12.7	10.3	7.9	5.6
KW	1.1	1.0	1.0	1.0	1.0	1.0	0.9	0.9	0.9	0.8	0.8	0.8	0.8	0.7	0.7	0.7	0.6
AMPS	3.9	3.7	3.6	3.5	3.4	3.3	3.2	3.0	2.9	2.8	2.6	2.5	2.5	2.3	2.2	2.1	1.9
COP	6.08	5.84	5.59	5.32	5.13	4.97	4.55	4.15	3.84	3.62	3.47	3.40	3.25	2.86	2.44	1.97	1.45
Hi PR	392	379	366	354	346	341	328	315	303	290	277	270	264	252	239	226	213
LO PR	147	138	129	119	114	110	101	92	83	74	65	59	55	46	37	28	19

GLZT7CA3610A*+DMVT42CP1300A*

70 % CAPACITY

	OUTDOOR AMBIENT TEMPERATURE																
	65	60	55	50	47	45	40	35	30	25	20	17	15	10	5	0	-5
MBh	32.9	30.7	28.4	26.2	24.8	23.7	21.0	18.6	16.6	15.1	14.0	13.4	12.6	10.7	8.8	6.9	5.0
T/R	35.5	33.3	31.2	29.1	27.8	26.6	23.6	20.8	18.6	16.9	15.7	15.0	14.2	12.0	9.9	7.8	5.6
KW	1.6	1.6	1.5	1.5	1.5	1.4	1.4	1.4	1.3	1.3	1.2	1.2	1.2	1.1	1.1	1.0	1.0
AMPS	5.8	5.6	5.4	5.2	5.1	5.0	4.8	4.6	4.4	4.2	4.0	3.9	3.8	3.6	3.4	3.2	3.0
COP	5.93	5.68	5.42	5.15	4.97	4.81	4.41	4.03	3.72	3.51	3.37	3.30	3.16	2.79	2.40	1.96	1.49
Hi PR	392	379	366	354	346	341	328	315	303	290	277	270	264	252	239	226	213
LO PR	147	138	129	119	114	110	101	92	83	74	65	59	55	46	37	28	19

GLZT7CA4810A*+DMVT60DP1300A*

70 % CAPACITY

	OUTDOOR AMBIENT TEMPERATURE																
	65	60	55	50	47	45	40	35	30	25	20	17	15	10	5	0	-5
MBh	45.9	42.8	39.8	36.9	35.0	33.6	30.0	26.7	24.1	22.1	20.6	19.8	18.8	16.2	13.7	11.2	8.6
T/R	40.4	38.1	35.8	33.5	32.1	30.8	27.5	24.5	22.1	20.2	18.9	18.1	17.2	14.9	12.6	10.2	7.9
KW	2.3	2.2	2.2	2.1	2.1	2.0	2.0	1.9	1.8	1.8	1.7	1.7	1.7	1.6	1.5	1.5	1.4
AMPS	8.3	8.0	7.7	7.5	7.3	7.2	7.0	6.7	6.4	6.2	5.9	5.7	5.6	5.4	5.1	4.8	4.6
COP	5.92	5.68	5.43	5.17	4.99	4.85	4.47	4.11	3.82	3.62	3.50	3.44	3.31	2.97	2.61	2.21	1.79
Hi PR	429	415	401	387	379	373	359	345	331	318	304	295	290	276	262	248	234
LO PR	141	132	123	114	109	106	97	88	79	71	62	57	53	44	36	27	18

GLZT7CA6010A*+DMVT60DP1300A*

70 % CAPACITY

	OUTDOOR AMBIENT TEMPERATURE																
	65	60	55	50	47	45	40	35	30	25	20	17	15	10	5	0	-5
MBh	54.5	50.9	47.5	44.0	41.8	40.2	36.1	32.3	29.2	26.9	25.2	24.3	23.1	20.2	17.2	14.3	11.4
T/R	40.5	38.2	36.0	33.7	32.3	31.1	27.9	25.0	22.6	20.8	19.5	18.8	17.8	15.6	13.3	11.1	8.8
KW	2.8	2.7	2.6	2.5	2.5	2.5	2.4	2.3	2.2	2.2	2.1	2.0	2.0	1.9	1.9	1.8	1.7
AMPS	10.1	9.8	9.5	9.1	8.9	8.8	8.5	8.2	7.8	7.5	7.2	7.0	6.9	6.5	6.2	5.9	5.6
COP	5.79	5.56	5.33	5.09	4.92	4.79	4.43	4.09	3.82	3.64	3.53	3.48	3.36	3.04	2.70	2.34	1.94
Hi PR	392	379	366	354	346	341	328	315	303	290	277	270	264	252	239	226	213
LO PR	134	126	117	109	104	101	92	84	76	67	59	54	51	42	34	26	17

Calculations are based on nominal CFM and 70 °F indoor dry bulb.

Amps = Outdoor unit amps (comp.+fan)

Note: Shaded area is AHRI Rating Conditions at 47°F outdoor ambient temperature

kW = Total system power

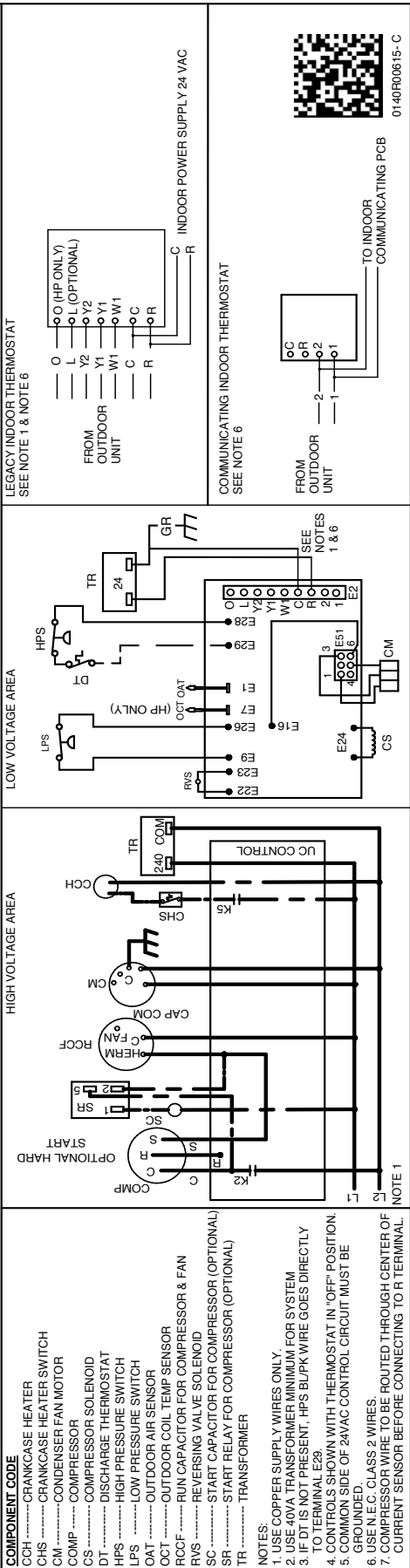
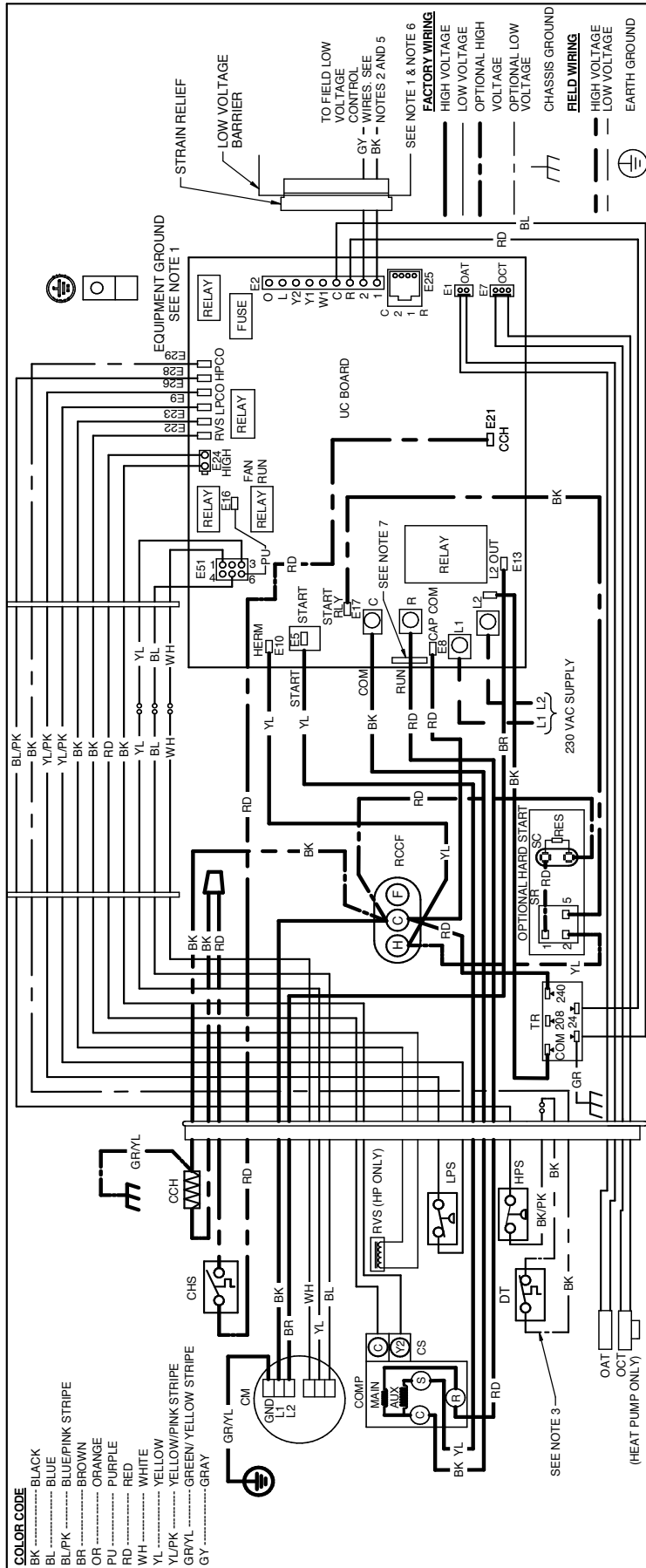

WARNING

High Voltage: Disconnect all power before servicing or installing this unit. Multiple power sources may be present. Failure to do so may cause property damage, personal injury, or death.

Wiring is subject to change. Always refer to the wiring diagram or the unit for the most up-to-date wiring.



01-40R00615-C

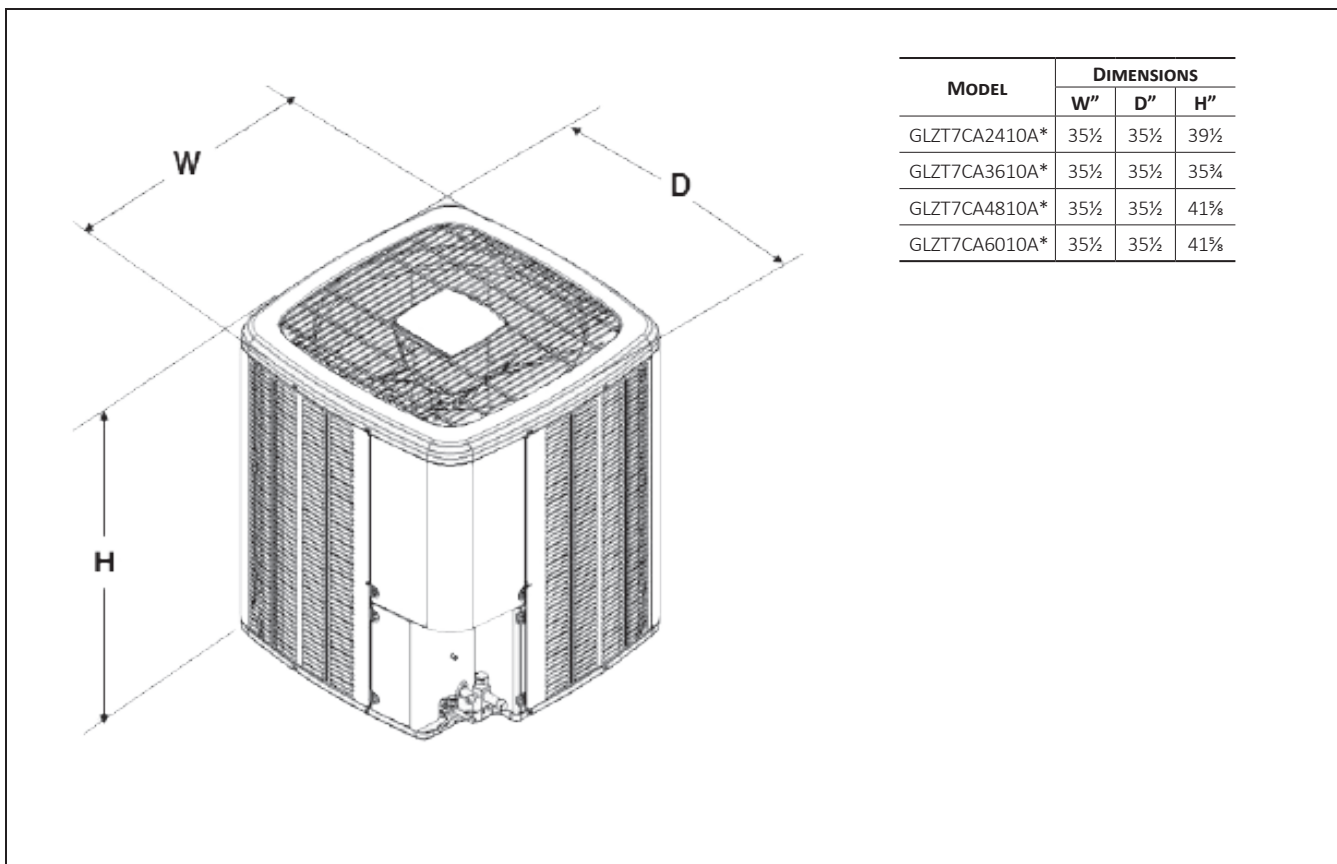

ACCESSORIES

MODEL	DESCRIPTION	GLZT7CA 2410A*	GLZT7CA 3610A*	GLZT7CA 4810A*	GLZT7CA 6010A*
ABK-20	Anchor Bracket Kit ◊	X	X	X	X
CSR-U-1	Hard-start Kit	X	X		
CSR-U-2	Hard-start Kit		X	X	X
CSR-U-3	Hard-start Kit			X	X
FSK01A ¹	Freeze Protection Kit	X	X	X	X
OT18-60A ²	Outdoor Thermostat w/ Lockout Stat	X	X	X	X
TXV-FX-KX-2T ³	TXV Kit	X			
TXV-FX-KX-3T ³	TXV Kit		X		
TXV-FX-KX-4T ³	TXV Kit			X	
TXV-FX-KX-5T ³	TXV Kit				X

Note: Maximum number of installed accessories at the same time is limited by the size of the unit's control box.

⁰ Contains 20 brackets; four brackets needed to anchor unit to pad

¹ Installed on indoor coil

² Available in 24V legacy mode only. This feature is integrated in the communicating mode. Required for heat pump applications where ambient temperature falls below 0 OF with 50% or higher relative humidity.

³ Condensing units and heat pumps with reciprocating or rotary compressors require the use of start-assist components when used in conjunction with an indoor coil using a non-bleed thermal expansion valve refrigerant metering device or liquid solenoid kit. The TXV should always be sized based on the tonnage of the outdoor unit.

All AHRI system ratings are accessible in the System Configurator tool via PartnerLink.

