

R-32 PACKAGED GAS / ELECTRIC UP TO 15.2 SEER2/ 81% AFUE 2 TO 5 TONS

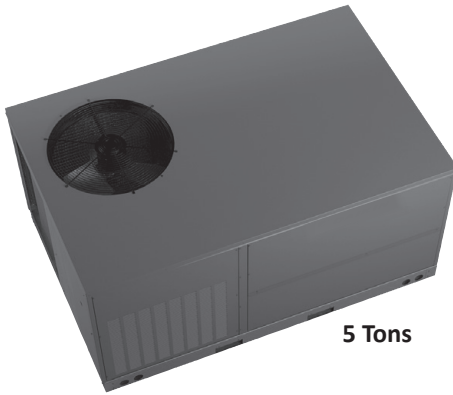

5 Tons



2 - 4 Tons

R32



Contents

Nomenclature.....	2
Product Specifications.....	3
Expanded Cooling Data.....	4
Airflow Data.....	28
Dimensions.....	32
Wiring Diagram.....	37
Accessories.....	39

Standard Features

- Durable, corrosion-resistant T-140 aluminized steel tubular heat exchanger
- High-efficiency two-stage scroll compressor
- Convertible airflow: horizontal or downflow application
- Variable-speed ECM indoor blower motor
- Copper tube/aluminum fin condenser coil
- All-aluminum evaporator coil on 2- to 4-ton units
- Aluminum-copper evaporator coil on 5-ton units
- Power-assisted combustion
- Loss-of-charge protection & high-pressure switch
- Two-stage gas valve; natural gas with easy conversion to propane with accessory kit
- Direct spark ignition system includes a microprocessor-based control for the entire ignition sequence
- All blower operation and all safety circuits complete with self-diagnostics
- All models comply with California Low NOx emission standards (40ng/J NOx)
- GPGM3 models comply with California Low NOx standards (40ng/J NOx), but are not eligible for installation in California's South Coast Air Quality Management District (SCAQMD), San Joaquin Valley Air Pollution Control District (SJVAPCD), or Bay Area Air Quality Management District (BAAQMD).
- AHRI Certified; UL Listed

Cabinet Features

- Fully insulated heavy-gauge, zinc-coated steel cabinet with UV-resistant powder-paint finish
- Aluminum foil-facing internal insulation reinforced with fiberglass scrim
- Convenient access panels
- One roof curb fits 2-4 ton units
- Bottom, 2" high base rails for easier handling
- 2-4 ton models fit a standard-size pick-up truck
- When properly anchored, meets the 2020 Florida Building Code unit integrity requirements for hurricane-type winds (Anchor bracket kits available.)
- Meets cabinet air leakage requirements when tested in accordance with ASHRAE standard 193

20 YEAR HEAT EXCHANGER LIMITED WARRANTY*

10 YEAR PARTS LIMITED WARRANTY*



COMPANY WITH ENVIRONMENTAL SYSTEM CERTIFIED BY DNV GL = ISO 14001 =

COMPANY WITH QUALITY SYSTEM CERTIFIED BY DNV GL = ISO 9001 =



* Complete warranty details available from your local dealer or at www.goodmanmfg.com. To receive the 20-Year Heat Exchanger Limited Warranty (good for as long as you own your home), and 10-Year Parts Limited Warranty, online registration must be completed within 60 days of installation. Online registration and some of the additional requirements are not required in Florida, California, or Québec. The duration of warranty coverage in Texas and Florida differs in some cases. Other limitations and exclusions apply; refer to complete warranty details for a full list of limitations and exclusions.

NOMENCLATURE

	G	P	G	M	5	36	120	3	1	A	A	
	1	2	3	4	5	6,7	8,9,10	11	12	13	14	
Brand G- Goodman Brand											Minor Revision A	
Product Category P - Packaged Unit											Major Revision A	
Unit Type G - Gas/Electric D - Dual Fuel U - Ultra Low NOx											Electrical 1 - 208/230V single-phase, 60 Hz 3 - 208/230 V,3 Phase, 60 Hz	
Airflow M - Multi-position											Refrigerant 3 - R-32	
Efficiency 3 13.4 SEER2 5 15.2 SEER2											Heat Input 060 60 MBTU/H 100 100 MBTU/H 080 80 MBTU/H 140 140 MBTU/H	
											Tonnage Nominal 24 - 2 tons 42 - 3½ tons 30 - 2½ tons 48 - 4 tons 36 - 3 tons 60 - 5 tons	

	GPGM5 2406031	GPGM5 3008031	GPGM5 3608031	GPGM5 4210031	GPGM5 4810031	GPGM5 6014031
COOLING CAPACITY						
Total BTU/h	23,800	29,400	35,600	41,500	46,000	59,000
Sensible BTU/h	18,370	23,100	28,550	30,040	32,600	43,660
SEER2	15.2	14.8	15.2	15.2	15.2	15.4
EER2	11.5	11.5	11.5	11.5	11.5	11.5
Decibels	78	73	76	76	77	78
HEATING CAPACITY (BTU/H)						
Input BTU/h	60,000 / 45,000	80,000 / 60,000	80,000 / 60,000	100,000 / 75,000	100,000 / 75,000	135000 / 101250
Output BTU/h	48600 / 36450	64800 / 48600	64800 / 48600	81000 / 60750	81000 / 60750	109350 / 82000
AFUE	81	81	81	81	81	81
Temperature Rise Range	25-55	35-65	35-65	35-65	35-65	35-65
No. of Burners	3	4	4	5	5	6
EVAPORATOR MOTOR						
Type	ECM	ECM	ECM	ECM	ECM	ECM
Wheel (D x W)	10" x 8"	10" x 9"	11" x 10"	11" x 10"	11" x 10"	11" x 10"
Indoor Nominal CFM	800	950	1,200	1,250	1,300	2,000
No. of Speeds	5	5	5	5	5	5
Indoor Blower FLA	9.8	9.8	5.4	5.4	5.4	6.9
Horsepower	1/2	1/2	3/4	3/4	3/4	1
Evaporator Coil						
FACE AREA (FT ²)	4.3	4.3	5.7	5.7	5.7	9.2
Rows Deep/Fins per Inch	3 / 14	3 / 14	3 / 14	3 / 14	3 / 14	4 / 16
Piston Size (Cooling)	TXV	TXV	TXV	TXV	TXV	TXV
Drain Size (NPT)	3/4"	3/4"	3/4"	3/4"	3/4"	3/4"
Refrigerant Charge (oz.)	58	49	80	118	82	100
Condenser Fan / Coil						
OUTDOOR FAN FLA	0.98	1.3	1.4	1.4	1.4	2.6
Horsepower	1/6	1/4	1/4	1/4	1/4	1/3
Blade Diameter	22"	22"	22"	22"	22"	22"
Outdoor Nominal CFM	2,279	1,895	2,741	2,927	2,741	4,200
Face Area (ft ²)	12.3	8.7	14.4	14.9	14.4	19
Rows Deep/Fins per Inch	1 / 24	2 / 27	2 / 27	2 / 16	2 / 27	2 / 28
Compressor						
TYPE	Scroll	Scroll	Scroll	Scroll	Scroll	Scroll
Stage	2	2	2	2	2	2
RLA	10	13	15	18	23	27
LRA	67.5	88	91	126	128.4	178
ELECTRICAL DATA						
Voltage (Frequency 60Hz)	208/230	208/230	208/230	208/230	208/230	208/230
Phase	1	1	1	1	1	1
Min. Circuit Ampacity	17.2	21.4	25	29.8	35.8	43.3
Max. Overcurrent Protection	25	30	35	45	50	70
OPERATING / SHIP WEIGHTS (LBS)						
	370 / 380	370 / 380	380 / 410	380 / 410	400 / 410	400 / 410

¹ Wire size should be determined in accordance with National Electrical Codes. Extensive wire runs will require larger wire sizes.

² Must use time-delay fuses or HACR-type circuit breakers of the same size as noted.

Note: Always check the S&R plate for electrical data on the unit being installed.

EXPANDED COOLING DATA — GPGM524***31 LOW STAGE

IDB	AIRFLOW	OUTDOOR AMBIENT TEMPERATURE																																																							
		65°F						75°F						85°F						95°F						105°F						115°F																									
		59	63	67	71	59	63	67	71	59	63	67	71	59	63	67	71	59	63	67	71	59	63	67	71	59	63	67	71																												
500	MBh	17.3	17.6	18.1	-	17.2	17.4	18.0	-	16.7	17.0	17.5	-	15.9	16.2	16.7	-	15.0	15.2	15.8	-	14.1	14.4	14.9	-	15.0	15.2	15.8	-	14.1	14.4	14.9	-	15.0	15.2	15.8	-	14.1	14.4	14.9	-	15.0	15.2	15.8	-	14.1	14.4	14.9	-	15.0	15.2	15.8	-	14.1	14.4	14.9	-
	S/T	0.60	0.53	0.38	-	0.61	0.53	0.39	-	0.64	0.56	0.42	-	1.00	0.58	0.44	-	1.00	0.60	0.46	-	1.00	0.66	0.51	-	1.00	0.60	0.46	-	1.00	0.66	0.51	-	1.00	0.60	0.46	-	1.00	0.66	0.51	-	1.00	0.60	0.46	-	1.00	0.66	0.51	-	1.00	0.60	0.46	-	1.00	0.66	0.51	-
	ΔT	19.51	17.75	14.45	-	19.47	17.70	14.40	-	19.71	17.95	14.65	-	19.45	17.68	14.38	-	19.21	17.44	14.15	-	20.32	18.55	15.25	-	19.21	17.44	14.15	-	20.32	18.55	15.25	-	19.21	17.44	14.15	-	20.32	18.55	15.25	-	19.21	17.44	14.15	-	20.32	18.55	15.25	-	19.21	17.44	14.15	-	20.32	18.55	15.25	-
	kW	1001	1000	998	-	1127	1126	1123	-	1266	1265	1263	-	1418	1417	1415	-	1587	1586	1584	-	1786	1785	1782	-	1587	1586	1584	-	1786	1785	1782	-	1587	1586	1584	-	1786	1785	1782	-	1587	1586	1584	-	1786	1785	1782	-	1587	1586	1584	-	1786	1785	1782	-
	Amps	3.80	3.80	3.79	-	4.35	4.34	4.33	-	4.95	4.95	4.94	-	5.61	5.61	5.60	-	6.35	6.34	6.33	-	7.21	7.21	7.20	-	6.35	6.34	6.33	-	7.21	7.21	7.20	-	6.35	6.34	6.33	-	7.21	7.21	7.20	-	6.35	6.34	6.33	-	7.21	7.21	7.20	-	6.35	6.34	6.33	-	7.21	7.21	7.20	-
	Hi PR	244	245	247	-	283	284	286	-	324	325	326	-	367	368	370	-	414	415	417	-	464	465	467	-	414	415	417	-	464	465	467	-	414	415	417	-	464	465	467	-	414	415	417	-	464	465	467	-	414	415	417	-	464	465	467	-
	Lo PR	128	129	133	-	136	137	140	-	142	144	147	-	148	150	153	-	154	155	159	-	161	163	166	-	154	155	159	-	161	163	166	-	154	155	159	-	161	163	166	-	154	155	159	-	161	163	166	-	154	155	159	-	161	163	166	-
	MBh	17.6	17.9	18.4	-	17.5	17.7	18.2	-	17.0	17.3	17.8	-	16.2	16.5	17.0	-	15.3	15.5	16.1	-	14.4	14.7	15.2	-	15.3	15.5	16.1	-	14.4	14.7	15.2	-	15.3	15.5	16.1	-	14.4	14.7	15.2	-	15.3	15.5	16.1	-	14.4	14.7	15.2	-	15.3	15.5	16.1	-	14.4	14.7	15.2	-
	S/T	0.70	0.62	0.47	-	0.70	0.62	0.48	-	1.00	0.65	0.51	-	1.00	0.67	0.53	-	1.00	0.69	0.55	-	1.00	1.00	0.60	-	1.00	0.69	0.55	-	1.00	1.00	0.60	-	1.00	0.69	0.55	-	1.00	1.00	0.60	-	1.00	0.69	0.55	-	1.00	1.00	0.60	-	1.00	0.69	0.55	-	1.00	1.00	0.60	-
	ΔT	18.04	16.27	12.97	-	17.99	16.22	12.92	-	18.24	16.47	13.17	-	17.97	16.20	12.90	-	17.73	15.97	12.67	-	18.84	17.07	13.77	-	17.73	15.97	12.67	-	18.84	17.07	13.77	-	17.73	15.97	12.67	-	18.84	17.07	13.77	-	17.73	15.97	12.67	-	18.84	17.07	13.77	-	17.73	15.97	12.67	-	18.84	17.07	13.77	-
kW	1010	1009	1007	-	1136	1135	1132	-	1275	1274	1272	-	1427	1426	1424	-	1596	1595	1593	-	1795	1794	1791	-	1596	1595	1593	-	1795	1794	1791	-	1596	1595	1593	-	1795	1794	1791	-	1596	1595	1593	-	1795	1794	1791	-	1596	1595	1593	-	1795	1794	1791	-	
Amps	3.84	3.84	3.83	-	4.38	4.38	4.37	-	4.99	4.99	4.98	-	5.65	5.65	5.64	-	6.39	6.38	6.37	-	7.25	7.25	7.24	-	6.39	6.38	6.37	-	7.25	7.25	7.24	-	6.39	6.38	6.37	-	7.25	7.25	7.24	-	6.39	6.38	6.37	-	7.25	7.25	7.24	-	6.39	6.38	6.37	-	7.25	7.25	7.24	-	
Hi PR	247	248	250	-	286	287	289	-	326	327	329	-	370	371	373	-	417	418	420	-	467	468	470	-	417	418	420	-	467	468	470	-	417	418	420	-	467	468	470	-	417	418	420	-	467	468	470	-	417	418	420	-	467	468	470	-	
Lo PR	130	132	135	-	138	140	143	-	145	146	150	-	151	152	156	-	156	158	161	-	163	165	168	-	156	158	161	-	163	165	168	-	156	158	161	-	163	165	168	-	156	158	161	-	163	165	168	-	156	158	161	-	163	165	168	-	
MBh	18.0	18.3	18.8	-	17.9	18.1	18.6	-	17.4	17.7	18.2	-	16.6	16.9	17.4	-	15.7	15.9	16.4	-	14.8	15.0	15.6	-	15.7	15.9	16.4	-	14.8	15.0	15.6	-	15.7	15.9	16.4	-	14.8	15.0	15.6	-	15.7	15.9	16.4	-	14.8	15.0	15.6	-									
S/T	0.74	0.66	0.52	-	0.74	0.66	0.52	-	1.00	0.69	0.55	-	1.00	0.71	0.57	-	1.00	0.73	0.59	-	1.00	1.00	0.65	-	1.00	0.73	0.59	-	1.00	1.00	0.65	-	1.00	0.73	0.59	-	1.00	1.00	0.65	-	1.00	0.73	0.59	-	1.00	1.00	0.65	-									
ΔT	16.86	15.10	11.80	-	16.82	15.05	11.75	-	17.06	15.30	12.00	-	16.80	15.03	11.73	-	16.56	14.79	11.50	-	17.67	15.90	12.60	-	16.56	14.79	11.50	-	17.67	15.90	12.60	-	16.56	14.79	11.50	-	17.67	15.90	12.60	-	16.56	14.79	11.50	-	17.67	15.90	12.60	-									
kW	1017	1016	1014	-	1143	1142	1140	-	1283	1282	1279	-	1434	1433	1431	-	1603	1602	1600	-	1802	1801	1799	-	1603	1602	1600	-	1802	1801	1799	-	1603	1602	1600	-	1802	1801	1799	-	1603	1602	1600	-	1802	1801	1799	-									
Amps	3.87	3.87	3.86	-	4.42	4.41	4.40	-	5.02	5.02	5.01	-	5.68	5.68	5.67	-	6.42	6.41	6.40	-	7.28	7.28	7.27	-	6.42	6.41	6.40	-	7.28	7.28	7.27	-	6.42	6.41	6.40	-	7.28	7.28	7.27	-	6.42	6.41	6.40	-	7.28	7.28	7.27	-									
Hi PR	250	251	253	-	289	290	291	-	329	330	332	-	373	374	375	-	420	421	423	-	470	471	473	-	420	421	423	-	470	471	473	-	420	421	423	-	470	471	473	-	420	421	423	-	470	471	473	-									
Lo PR	133	135	138	-	141	142	146	-	148	149	153	-	154	155	158	-	159	161	164	-	166	168	171	-	159	161	164	-	166	168	171	-	159	161	164	-	166	168	171	-	159	161	164	-	166	168	171	-									
MBh	17.4	17.6	18.1	18.9	17.2	17.4	18.0	18.8	16.7	17.0	17.5	18.3	16.0	16.2	16.7	17.5	15.0	15.2	15.8	16.6	14.1	14.4	14.9	15.7	15.0	15.2	15.8	16.6	14.1	14.4	14.9	15.7	15.0	15.2	15.8	16.6	14.1	14.4	14.9	15.7	15.0	15.2	15.8	16.6	14.1	14.4	14.9	15.7									
S/T	0.74	0.66	0.52	0.4	1.00	0.67	0.52	0.4	1.00	0.69	0.55	0.4	1.00	0.71	0.57	0.4	1.00	0.73	0.59	0.4	1.00	1.00	0.65	0.5	1.00	0.73	0.59	0.4	1.00	1.00	0.65	0.5	1.00	0.73	0.59	0.4	1.00	1.00	0.65	0.5	1.00	0.73	0.59	0.4	1.00	1.00	0.65	0.5									
ΔT	23.40	21.63	18.33	14.9	23.35	21.58	18.28	14.9	23.60	21.83	18.53	15.1	23.33	21.57	18.27	14.8	23.10	21.33	18.03	14.6	24.20	22.44	19.14	15.7	23.10	21.33	18.03	14.6	24.20	22.44	19.14	15.7	23.10	21.33	18.03	14.6	24.20	22.44	19.14	15.7	23.10	21.33	18.03	14.6	24.20	22.44	19.14	15.7									
kW	1000	999	997	1007	1126	1125	1123	1132	1266	1265	1263	1272	1417	1416	1414	1424	1586	1585	1583	1593	1785	1784	1782	1791	1586	1585	1583	1593	1785	1784	1782	1791	1586	1585	1583	1593	1785	1784	1782	1791	1586	1585	1583	1593	1785	1784	1782	1791									
Amps	3.80	3.79	3.78	3.8	4.34	4.34	4.33	4.4	4.95	4.95	4.94	5.0	5.61	5.60	5.60	5.6	6.34	6.34	6.33	6.4	7.21	7.20	7.19	7.2	6.34	6.34	6.33	6.4	7.21	7.20	7.19	7.2	6.34	6.34	6.33	6.4	7.21	7.20	7.19	7.2	6.34	6.34	6.33	6.4	7.21	7.20	7.19	7.2									
Hi PR	245	246	247	251.6	283	284	286	290.3	324	325	327	330.8	367	368	370	374.5	414	415	417	421.5	465	466	467	471.7	414	415	417	421.5	465	466	467	471.7	414	415	417	421.5	465	466	467	471.7	414	415	417	421.5	465	466	467	471.7									
Lo PR																																																									

EXPANDED COOLING DATA — GPGM524***31 LOW STAGE (CONT.)

IDB	AIRFLOW	OUTDOOR AMBIENT TEMPERATURE																																															
		65°F						75°F						85°F						95°F						105°F						115°F																	
		59	63	67	71	75	79	59	63	67	71	75	79	59	63	67	71	75	79	59	63	67	71	75	79	59	63	67	71	75	79	59	63	67	71	75	79												
		ENTERING INDOOR WET BULB TEMPERATURE																																															
80	MBh	17.4	17.7	18.2	19.0	17.3	17.5	18.1	18.8	16.8	17.1	17.6	18.4	16.0	16.3	16.8	17.6	15.1	15.3	15.9	16.7	14.2	14.5	15.0	15.8	17.4	17.7	18.2	19.0	17.3	17.5	18.1	18.8	16.8	17.1	17.6	18.4	16.0	16.3	16.8	17.6	15.1	15.3	15.9	16.7	14.2	14.5	15.0	15.8
	S/T	1.00	0.79	0.65	0.5	1.00	0.80	0.66	0.5	1.00	0.82	0.68	0.5	1.00	1.00	0.70	0.6	1.00	1.00	0.73	0.6	1.00	1.00	0.78	0.6	1.00	0.79	0.65	0.5	1.00	0.80	0.66	0.5	1.00	0.82	0.68	0.5	1.00	1.00	0.70	0.6	1.00	1.00	0.73	0.6	1.00	1.00	0.78	0.6
	ΔT	27.31	25.54	22.24	18.8	27.26	25.49	22.20	18.8	27.51	25.74	22.44	19.0	27.24	25.48	22.18	18.8	27.01	25.24	21.94	18.5	27.01	25.24	21.94	18.5	27.31	25.54	22.24	18.8	27.26	25.49	22.20	18.8	27.51	25.74	22.44	19.0	27.24	25.48	22.18	18.8	27.01	25.24	21.94	18.5	27.01	25.24	21.94	18.5
	kW	1001	1000	998	1008	1126	1125	1123	1133	1266	1265	1263	1273	1418	1417	1415	1424	1587	1586	1584	1593	1785	1784	1782	1792	1001	1000	998	1008	1126	1125	1123	1133	1266	1265	1263	1273	1418	1417	1415	1424	1587	1586	1584	1593	1785	1784	1782	1792
	Amps	3.80	3.80	3.79	3.8	4.34	4.34	4.33	4.4	4.95	4.95	4.94	5.0	5.61	5.61	5.60	5.6	6.35	6.34	6.33	6.4	7.21	7.21	7.20	7.2	3.80	3.80	3.79	3.8	4.34	4.34	4.33	4.4	4.95	4.95	4.94	5.0	5.61	5.61	5.60	5.6	6.35	6.34	6.33	6.4	7.21	7.21	7.20	7.2
Hi PR	245	246	248	252.1	284	285	286	290.8	324	325	327	331.3	368	369	371	374.9	415	416	418	421.9	465	466	468	472.1	245	246	248	252.1	284	285	286	290.8	324	325	327	331.3	368	369	371	374.9	415	416	418	421.9	465	466	468	472.1	
Lo PR	128	130	133	138.7	136	138	141	146.5	143	145	148	153.3	149	150	154	159.1	154	156	159	164.8	162	163	166	171.9	128	130	133	138.7	136	138	141	146.5	143	145	148	153.3	149	150	154	159.1	154	156	159	164.8	162	163	166	171.9	
80	MBh	17.7	18.0	18.5	19.3	17.6	17.8	18.3	19.1	17.1	17.4	17.9	18.7	16.3	16.6	17.1	17.9	15.4	15.6	16.2	17.0	14.5	14.8	15.3	16.1	17.7	18.0	18.5	19.3	17.6	17.8	18.3	19.1	17.1	17.4	17.9	18.7	16.3	16.6	17.1	17.9	15.4	15.6	16.2	17.0	14.5	14.8	15.3	16.1
	S/T	1.00	0.88	0.74	0.6	1.00	0.89	0.75	0.6	1.00	1.00	0.77	0.6	1.00	1.00	0.79	0.6	1.00	1.00	0.82	0.7	1.00	1.00	0.78	0.7	1.00	0.88	0.74	0.6	1.00	0.89	0.75	0.6	1.00	1.00	0.77	0.6	1.00	1.00	0.79	0.6	1.00	1.00	0.82	0.7	1.00	1.00	0.78	0.7
	ΔT	25.83	24.07	20.77	17.3	25.78	24.02	20.72	17.3	26.03	24.27	20.97	17.5	25.77	24.00	20.70	17.3	25.53	23.76	20.46	17.0	26.64	24.87	21.57	18.2	25.83	24.07	20.77	17.3	25.78	24.02	20.72	17.3	26.03	24.27	20.97	17.5	25.77	24.00	20.70	17.3	25.53	23.76	20.46	17.0	26.64	24.87	21.57	18.2
	kW	1010	1009	1007	1017	1135	1134	1132	1142	1275	1274	1272	1282	1427	1426	1424	1433	1596	1595	1593	1602	1794	1793	1791	1801	1010	1009	1007	1017	1135	1134	1132	1142	1275	1274	1272	1282	1427	1426	1424	1433	1596	1595	1593	1602	1794	1793	1791	1801
	Amps	3.84	3.83	3.83	3.9	4.38	4.38	4.37	4.4	4.99	4.99	4.98	5.0	5.65	5.65	5.64	5.7	6.39	6.38	6.37	6.4	7.25	7.24	7.24	7.3	3.84	3.83	3.83	3.9	4.38	4.38	4.37	4.4	4.99	4.99	4.98	5.0	5.65	5.65	5.64	5.7	6.39	6.38	6.37	6.4	7.25	7.24	7.24	7.3
Hi PR	248	249	251	254.9	287	288	289	293.6	327	328	330	334.1	371	372	373	377.7	418	419	420	424.8	468	469	471	475.0	248	249	251	254.9	287	288	289	293.6	327	328	330	334.1	371	372	373	377.7	418	419	420	424.8	468	469	471	475.0	
Lo PR	131	132	136	141.1	139	140	143	149.0	145	147	150	155.8	151	153	156	161.6	157	159	162	167.2	164	166	169	174.4	131	132	136	141.1	139	140	143	149.0	145	147	150	155.8	151	153	156	161.6	157	159	162	167.2	164	166	169	174.4	
700	MBh	18.1	18.4	18.9	19.7	18.0	18.2	18.7	19.5	17.5	17.8	18.3	19.1	16.7	17.0	17.5	18.3	15.8	16.0	16.5	17.3	14.9	15.1	15.7	16.5	18.1	18.4	18.9	19.7	18.0	18.2	18.7	19.5	17.5	17.8	18.3	19.1	16.7	17.0	17.5	18.3	15.8	16.0	16.5	17.3	14.9	15.1	15.7	16.5
	S/T	1.00	0.92	0.78	0.6	1.00	0.93	0.79	0.6	1.00	1.00	0.81	0.7	1.00	1.00	0.83	0.7	1.00	1.00	0.86	0.7	1.00	1.00	0.80	0.8	1.00	0.92	0.78	0.6	1.00	0.93	0.79	0.6	1.00	1.00	0.81	0.7	1.00	1.00	0.83	0.7	1.00	1.00	0.86	0.7	1.00	1.00	0.80	0.8
	ΔT	24.66	22.89	19.59	16.2	24.61	22.84	19.55	16.1	24.86	23.09	19.79	16.4	24.59	22.83	19.53	16.1	24.36	22.59	19.29	15.9	25.46	23.70	20.40	17.0	24.66	22.89	19.59	16.2	24.61	22.84	19.55	16.1	24.86	23.09	19.79	16.4	24.59	22.83	19.53	16.1	24.36	22.59	19.29	15.9	25.46	23.70	20.40	17.0
	kW	1017	1016	1014	1024	1143	1142	1139	1149	1282	1281	1279	1289	1434	1433	1431	1440	1603	1602	1600	1609	1801	1800	1798	1808	1017	1016	1014	1024	1143	1142	1139	1149	1282	1281	1279	1289	1434	1433	1431	1440	1603	1602	1600	1609	1801	1800	1798	1808
	Amps	3.87	3.87	3.86	3.9	4.41	4.41	4.40	4.4	5.02	5.02	5.01	5.1	5.68	5.68	5.67	5.7	6.42	6.41	6.40	6.4	7.28	7.28	7.27	7.3	3.87	3.87	3.86	3.9	4.41	4.41	4.40	4.4	5.02	5.02	5.01	5.1	5.68	5.68	5.67	5.7	6.42	6.41	6.40	6.4	7.28	7.28	7.27	7.3
Hi PR	251	252	253	257.6	289	290	292	296.3	330	331	333	336.8	373	374	376	380.4	420	421	423	427.5	471	472	473	477.7	251	252	253	257.6	289	290	292	296.3	330	331	333	336.8	373	374	376	380.4	420	421	423	427.5	471	472	473	477.7	
Lo PR	134	135	139	144.0	141	143	146	151.8	148	150	153	158.6	154	156	159	164.4	160	161	165	170.1	167	168	172	177.2	134	135	139	144.0	141	143	146	151.8	148	150	153	158.6	154	156	159	164.4	160	161	165	170.1	167	168	172	177.2	
500	MBh	17.7	18.0	18.5	19.3	17.6	17.8	18.3	19.1	17.1	17.4	17.9	18.7	16.3	16.6	17.1	17.9	15.4	15.6	16.2	17.0	14.5	14.8	15.3	16.1	17.7	18.0	18.5	19.3	17.6	17.8	18.3	19.1	17.1	17.4	17.9	18.7	16.3	16.6	17.1	17.9	15.4	15.6	16.2	17.0	14.5	14.8	15.3	16.1
	S/T	1.00	0.90	0.76	0.6	1.00	0.91	0.77	0.6	1.00	1.00	0.82	0.7	1.00	1.00	0.84	0.7	1.00	1.00	0.87	0.7	1.00	1.00	0.81	0.8	1.00	0.90	0.76	0.6	1.00	0.91	0.77	0.6	1.00	1.00	0.82	0.7	1.00	1.00	0.84	0.7	1.00	1.00	0.87	0.7	1.00	1.00	0.81	0.8
	ΔT	30.78	29.01	25.71	22.3	30.73	28.96	25.66	22.2	30.98	29.21	25.91	22.5	30.71	28.95	25.65	22.2	30.48	28.71	25.41	22.0	31.58	29.82	26.52	23.1	30.78	29.01	25.71	22.3	30.73	28.96	25.66	22.2	30.98	29.21	25.91	22.5	30.71	28.95	25.65	22.2	30.48	28.71	25.41	22.0	31.58	29.82	26.52	23.1
	kW	1003	1002	1000	1010	1129	1128	1126	1135	1269	1268	1266	1275	1420	1419	1417	1427	1589	1588	1586	1596	1788	1787	1785	1794	1003	1002	1000	1010	1129	1128	1126	1135	1269	1268	1266	1275	1420	1419	1417	1427	1589	1588	1586	1596	1788	1787	1785	1794
	Amps	3.81	3.81	3.80	3.8	4.36	4.35	4.34	4.4	4.96	4.96	4.95	5.0	5.62	5.62	5.61	5.7	6.36	6.35	6.34	6.4	7.22	7.22	7.21	7.2	3.81	3.81	3.80	3.8	4.36	4.35	4.34	4.4	4.96	4.96	4.95	5.0	5.62	5.62	5.61	5.7	6.36	6.35	6.34	6.4	7.22	7.22	7.21	7.2
Hi PR	246	247	249	253.2	285	286	288	291.9	325	326	328	332.4	369	370	372	376.1	416	417	419	423.1	466	467	469	473.3	246	247	249																						

EXPANDED COOLING DATA — GPGM524***31 HIGH STAGE

IDB	AIRFLOW	OUTDOOR AMBIENT TEMPERATURE																							
		65°F				75°F				85°F				95°F				105°F				115°F			
		59	63	67	71	59	63	67	71	59	63	67	71	59	63	67	71	59	63	67	71	59	63	67	71
600	MBh	23.9	24.3	25.0	-	23.7	24.1	24.8	-	23.1	23.4	24.2	-	22.0	22.3	23.1	-	20.7	21.0	21.7	-	19.5	19.8	20.5	-
	S/T	0.52	0.44	0.31	-	0.53	0.45	0.31	-	0.55	0.48	0.34	-	0.57	0.50	0.36	-	1.00	0.52	0.38	-	1.00	0.57	0.43	-
	ΔT	21.19	19.36	15.94	-	21.14	19.31	15.89	-	21.40	19.57	16.15	-	21.12	19.29	15.87	-	20.88	19.05	15.63	-	22.02	20.19	16.77	-
	kW	1583	1581	1578	-	1782	1780	1777	-	2004	2003	1999	-	2245	2244	2240	-	2514	2512	2509	-	2830	2828	2825	-
	Amps	6.00	6.00	5.98	-	6.87	6.86	6.85	-	7.84	7.83	7.81	-	8.88	8.88	8.86	-	10.05	10.05	10.03	-	11.42	11.42	11.40	-
70	Hi PR	254	255	257	-	294	296	297	-	337	338	340	-	382	384	385	-	432	433	435	-	484	485	487	-
	Lo PR	123	125	128	-	131	132	135	-	137	139	142	-	143	145	148	-	148	150	153	-	155	157	160	-
	MBh	24.5	24.9	25.6	-	24.3	24.7	25.4	-	23.7	24.0	24.7	-	22.6	22.9	23.7	-	21.3	21.6	22.3	-	20.1	20.4	21.1	-
	S/T	0.68	0.60	0.46	-	0.68	0.61	0.47	-	0.71	0.63	0.49	-	1.00	0.65	0.51	-	1.00	0.67	0.54	-	1.00	0.73	0.59	-
	ΔT	18.69	16.86	13.44	-	18.64	16.81	13.39	-	18.90	17.07	13.65	-	18.62	16.79	13.37	-	18.38	16.55	13.13	-	19.52	17.69	14.27	-
1000	kW	1606	1604	1601	-	1805	1804	1800	-	2028	2026	2023	-	2268	2267	2264	-	2537	2536	2532	-	2853	2851	2848	-
	Amps	6.10	6.10	6.08	-	6.97	6.96	6.95	-	7.94	7.93	7.92	-	8.98	8.98	8.96	-	10.15	10.15	10.13	-	11.53	11.52	11.50	-
	Hi PR	259	260	261	-	299	300	302	-	341	342	344	-	387	388	390	-	436	437	439	-	489	490	492	-
	Lo PR	127	128	131	-	134	136	139	-	141	142	146	-	147	148	151	-	152	154	157	-	159	161	164	-
	MBh	25.4	25.7	26.4	-	25.2	25.5	26.2	-	24.5	24.9	25.6	-	23.4	23.8	24.5	-	22.1	22.4	23.2	-	20.9	21.2	22.0	-

IDB	AIRFLOW	OUTDOOR AMBIENT TEMPERATURE																							
		65°F				75°F				85°F				95°F				105°F				115°F			
		59	63	67	71	59	63	67	71	59	63	67	71	59	63	67	71	59	63	67	71	59	63	67	71
600	MBh	24.0	24.3	25.0	26.1	23.7	24.1	24.8	25.9	23.1	23.5	24.2	25.3	22.0	22.4	23.1	24.2	20.7	21.0	21.8	22.9	19.5	19.8	20.5	21.6
	S/T	0.65	0.58	0.44	0.3	0.66	0.58	0.44	0.3	1.00	0.61	0.47	0.3	1.00	0.63	0.49	0.3	1.00	0.65	0.51	0.4	1.00	1.00	0.56	0.4
	ΔT	25.22	23.38	19.97	16.4	25.17	23.33	19.92	16.4	25.42	23.59	20.17	16.6	25.15	23.32	19.90	16.4	24.90	23.07	19.65	16.1	26.05	24.22	20.80	17.3
	kW	1581	1580	1576	1592	1781	1779	1776	1791	2003	2002	1998	2013	2244	2242	2239	2254	2513	2511	2508	2523	2828	2827	2823	2839
	Amps	6.00	5.99	5.98	6.0	6.86	6.86	6.84	6.9	7.83	7.82	7.81	7.9	8.88	8.87	8.86	8.9	10.05	10.04	10.03	10.1	11.42	11.41	11.40	11.5
75	Hi PR	254	255	257	261.6	295	296	298	302.0	337	338	340	344.4	383	384	386	390.0	432	433	435	439.2	484	485	487	491.7
	Lo PR	123	125	128	133.2	131	132	135	140.8	137	139	142	147.4	143	145	148	153.0	149	150	153	158.5	155	157	160	165.5
	MBh	24.5	24.9	25.6	26.7	24.3	24.7	25.4	26.5	23.7	24.0	24.8	25.9	22.6	23.0	23.7	24.8	21.3	21.6	22.3	23.4	20.1	20.4	21.1	22.2
	S/T	0.81	0.73	0.59	0.4	1.00	0.74	0.60	0.5	1.00	0.76	0.62	0.5	1.00	0.78	0.64	0.5	1.00	0.81	0.67	0.5	1.00	1.00	0.72	0.6
	ΔT	22.72	20.89	17.47	13.9	22.67	20.84	17.42	13.9	22.92	21.09	17.67	14.1	22.65	20.82	17.40	13.9	22.40	20.57	17.15	13.6	23.55	21.72	18.30	14.8
800	kW	1605	1603	1600	1615	1804	1802	1799	1814	2026	2025	2021	2037	2267	2266	2262	2277	2536	2535	2531	2546	2852	2850	2847	2862
	Amps	6.10	6.09	6.08	6.1	6.97	6.96	6.94	7.0	7.93	7.93	7.91	8.0	8.98	8.96	8.96	9.0	10.15	10.14	10.13	10.2	11.52	11.51	11.50	11.6
	Hi PR	259	260	262	266.2	299	300	302	306.6	342	343	345	349.0	387	388	390	394.6	436	438	439	443.8	489	490	492	496.3
	Lo PR	127	128	131	136.7	134	136	139	144.3	141	142	146	151.0	147	151	156.6	161.0	152	154	157	162.1	159	161	164	169.1
	MBh	25.4	25.7	26.5	27.6	25.2	25.5	26.2	27.3	24.5	24.9	25.6	26.7	23.5	23.8	24.5	25.6	22.1	22.5	23.2	24.3	20.9	21.2	22.0	23.1
1000	S/T	0.85	0.78	0.64	0.5	1.00	0.78	0.65	0.5	1.00	0.81	0.67	0.5	1.00	0.83	0.69	0.5	1.00	1.00	0.71	0.6	1.00	1.00	0.77	0.6
	ΔT	20.96	19.13	15.71	12.2	20.91	19.08	15.66	12.1	21.17	19.34	15.92	12.4	20.89	19.06	15.64	12.1	20.65	18.82	15.40	11.9	21.79	19.96	16.54	13.0
	kW	1621	1620	1616	1631	1820	1819	1815	1831	2043	2041	2038	2053	2284	2282	2279	2294	2552	2551	2547	2563	2868	2866	2863	2878
	Amps	6.17	6.16	6.15	6.2	7.04	7.03	7.01	7.1	8.00	8.00	7.98	8.0	9.05	9.04	9.03	9.1	10.22	10.21	10.20	10.3	11.59	11.58	11.57	11.6
	Hi PR	263	264	266	270.4	304	305	306	310.9	346	347	349	353.3	392	393	394	398.9	441	442	444	448.1	493	494	496	500.6
Lo PR	131	133	136	141.1	139	140	143	148.7	145	147	150	155.3	151	152	156	161.0	156	158	161	166.5	163	165	168	173.4	

IDB: Entering Indoor Dry Bulb Temperature
 High and low pressures are measured at the liquid and suction service valves.
 Shaded area reflects ACCA (TVA) conditions
 kW = Total system power
 Amps = outdoor unit amps (comp. + fan)

EXPANDED COOLING DATA — GPGM524***31 HIGH STAGE (CONT.)

IDB	AIRFLOW	OUTDOOR AMBIENT TEMPERATURE																							
		65°F				75°F				85°F				95°F				105°F				115°F			
		59	63	67	71	59	63	67	71	59	63	67	71	59	63	67	71	59	63	67	71	59	63	67	71
		ENTERING INDOOR WET BULB TEMPERATURE																							
		24.1	24.4	25.1	26.3	23.9	24.2	24.9	26.0	23.2	23.6	24.3	25.4	22.1	22.5	23.2	24.3	20.8	21.2	21.9	23.0	19.6	19.9	20.7	21.8
		1.0	0.7	0.6	0.4	1.0	0.7	0.6	0.4	1.0	0.7	0.6	0.5	1.0	0.8	0.6	0.5	1.0	1.0	0.6	0.5	1.0	1.0	0.7	0.5
		29.3	27.4	24.0	20.5	29.2	27.4	24.0	20.4	29.5	27.6	24.2	20.7	29.2	27.4	24.0	20.4	29.0	27.1	23.7	20.2	30.1	28.3	24.9	21.3
600	kW	1,582	1,581	1,577	1,593	1,782	1,780	1,777	1,792	2,004	2,003	1,999	2,014	2,245	2,243	2,240	2,255	2,514	2,512	2,509	2,524	2,829	2,828	2,824	2,840
	Amps	6.0	6.0	6.0	6.0	6.9	6.9	6.8	6.9	7.8	7.8	7.8	7.9	8.9	8.9	8.9	8.9	10.1	10.0	10.0	10.1	11.4	11.4	11.4	11.5
	Hi PR	254.6	255.8	257.6	262.0	295.1	296.2	298.0	302.5	337.5	338.6	340.4	344.9	383.1	384.2	386.0	390.5	432.3	433.4	435.2	439.7	484.8	485.9	487.7	492.2
	Lo PR	123.7	125.2	128.4	133.7	131.3	132.8	136.0	141.3	137.9	139.5	142.6	148.0	143.5	145.1	148.3	153.6	149.1	150.6	153.8	159.1	156.0	157.5	160.7	166.0
		24.7	25.0	25.7	26.8	24.5	24.8	25.5	26.6	23.8	24.2	24.9	26.0	22.7	23.1	23.8	24.9	21.4	21.7	22.5	23.6	20.2	20.5	21.3	22.4
		1.0	0.9	0.7	0.6	1.0	0.9	0.7	0.6	1.0	0.9	0.8	0.6	1.0	1.0	0.8	0.6	1.0	1.0	0.8	0.6	1.0	1.0	0.8	0.7
		26.8	24.9	21.5	18.0	26.7	24.9	21.5	17.9	27.0	25.1	21.7	18.2	26.7	24.9	21.5	17.9	26.5	24.6	21.2	17.7	27.6	25.8	22.4	18.8
800	kW	1,606	1,604	1,601	1,616	1,805	1,804	1,800	1,815	2,028	2,026	2,023	2,038	2,268	2,267	2,263	2,279	2,537	2,536	2,532	2,547	2,853	2,851	2,848	2,863
	Amps	6.1	6.1	6.1	6.1	7.0	7.0	6.9	7.0	7.9	7.9	7.9	8.0	9.0	9.0	9.0	9.0	10.2	10.1	10.1	10.2	11.5	11.5	11.5	11.6
	Hi PR	259.2	260.4	262.2	266.6	299.7	300.8	302.6	307.1	342.1	343.2	345.0	349.5	387.7	388.8	390.6	395.1	436.9	438.0	439.8	444.3	489.4	490.5	492.3	496.8
	Lo PR	127.3	128.8	132.0	137.3	134.9	136.4	139.6	144.9	141.5	143.1	146.2	151.5	147.1	148.7	151.9	157.2	152.7	154.2	157.4	162.7	159.6	161.1	164.3	169.6
		25.5	25.9	26.6	27.7	25.3	25.6	26.4	27.5	24.7	25.0	25.7	26.8	23.6	23.9	24.6	25.7	22.2	22.6	23.3	24.4	21.0	21.4	22.1	23.2
		1.0	0.9	0.8	0.6	1.0	0.9	0.8	0.6	1.0	1.0	0.8	0.7	1.0	1.0	0.8	0.7	1.0	1.0	0.8	0.7	1.0	1.0	0.7	0.7
		25.0	23.2	19.8	16.2	25.0	23.1	19.7	16.2	25.2	23.4	20.0	16.4	24.9	23.1	19.7	16.2	24.7	22.9	19.4	15.9	25.8	24.0	20.6	17.1
1000	kW	1,622	1,621	1,617	1,632	1,821	1,820	1,816	1,832	2,044	2,042	2,039	2,054	2,285	2,283	2,280	2,295	2,554	2,552	2,549	2,564	2,869	2,867	2,864	2,879
	Amps	6.2	6.2	6.2	6.2	7.0	7.0	7.0	7.1	8.0	8.0	8.0	8.1	9.1	9.0	9.0	9.1	10.2	10.2	10.2	10.3	11.6	11.6	11.6	11.6
	Hi PR	263.5	264.6	266.4	270.9	304.0	305.1	306.9	311.4	346.4	347.5	349.3	353.7	392.0	393.1	394.9	399.4	441.2	442.3	444.1	448.6	493.7	494.8	496.6	501.1
	Lo PR	131.6	133.2	136.3	141.6	139.2	140.7	143.9	149.2	145.9	147.4	150.6	155.9	151.5	153.0	156.2	161.5	157.0	158.5	161.7	167.0	163.9	165.5	168.6	174.0

		24.3	24.6	25.3	26.4	24.2	24.6	25.3	26.4	23.6	24.0	24.7	25.8	22.6	22.9	23.6	24.7	21.2	21.6	22.3	23.4	20.0	20.4	21.1	22.2
		1.0	0.8	0.7	0.5	1.0	1.0	0.7	0.5	1.0	1.0	0.7	0.6	1.0	1.0	0.7	0.6	1.0	1.0	0.7	0.6	1.0	1.0	1.0	0.6
		32.9	31.0	27.6	24.1	32.8	31.0	27.6	24.0	33.1	31.2	27.8	24.3	32.8	31.0	27.5	24.0	32.5	30.7	27.3	23.8	33.7	31.9	28.4	24.9
600	kW	1,586	1,585	1,581	1,596	1,785	1,784	1,781	1,796	2,008	2,006	2,003	2,018	2,249	2,247	2,244	2,259	2,518	2,516	2,513	2,528	2,833	2,832	2,828	2,843
	Amps	6.0	6.0	6.0	6.1	6.9	6.9	6.9	6.9	7.9	7.8	7.8	7.9	8.9	8.9	8.9	8.9	10.1	10.1	10.0	10.1	11.4	11.4	11.4	11.5
	Hi PR	255.9	257.0	258.8	263.2	296.3	297.4	299.2	303.7	338.7	339.8	341.6	346.1	384.3	385.4	387.2	391.7	433.5	434.6	436.4	440.9	486.0	487.2	489.0	493.4
	Lo PR	125.5	127.1	130.3	135.6	133.1	134.7	137.9	143.2	139.8	141.3	144.5	149.8	145.4	147.0	150.1	155.5	150.9	152.5	155.7	161.0	157.8	159.4	162.6	167.9
		25.1	25.4	26.1	27.2	24.9	25.2	25.9	27.0	24.2	24.6	25.3	26.4	23.1	23.5	24.2	25.3	21.8	22.2	22.9	24.0	20.6	20.9	21.7	22.8
		1.0	1.0	0.8	0.7	1.0	1.0	0.8	0.7	1.0	1.0	0.9	0.7	1.0	1.0	0.9	0.7	1.0	1.0	0.8	0.8	1.0	1.0	1.0	0.8
		30.4	28.5	25.1	21.6	30.3	28.5	25.1	21.5	30.6	28.7	25.3	21.8	30.3	28.5	25.0	21.5	30.1	28.2	24.8	21.3	31.2	29.4	25.9	22.4
800	kW	1,610	1,608	1,605	1,620	1,809	1,807	1,804	1,819	2,031	2,030	2,026	2,042	2,272	2,270	2,267	2,282	2,541	2,539	2,536	2,551	2,857	2,855	2,852	2,867
	Amps	6.1	6.1	6.1	6.2	7.0	7.0	7.0	7.0	8.0	7.9	7.9	8.0	9.0	9.0	9.0	9.0	10.2	10.2	10.1	10.2	11.5	11.5	11.5	11.6
	Hi PR	260.5	261.6	263.4	267.8	300.9	302.0	303.8	308.3	343.3	344.4	346.2	350.7	388.9	390.0	391.8	396.3	438.1	439.2	441.0	445.5	490.6	491.8	493.6	498.0
	Lo PR	129.1	130.7	133.9	139.2	136.7	138.3	141.4	146.8	143.4	144.9	148.1	153.4	149.0	150.5	153.7	159.0	154.5	156.1	159.2	164.6	161.4	163.0	166.2	171.5
		25.9	26.3	27.0	28.1	25.7	26.0	26.8	27.9	25.1	25.4	26.1	27.2	24.0	24.3	25.0	26.2	22.7	23.0	23.7	24.8	21.4	21.8	22.5	23.6
		1.0	1.0	0.9	0.7	1.0	1.0	0.9	0.7	1.0	1.0	0.9	0.8	1.0	1.0	0.9	0.8	1.0	1.0	0.8	0.8	1.0	1.0	1.0	0.9
		28.6	26.8	23.4	19.8	28.6	26.7	23.3	19.8	28.8	27.0	23.6	20.0	28.5	26.7	23.3	19.7	28.3	26.5	23.0	19.5	29.4	27.6	24.2	20.6
1000	kW	1,626	1,624	1,621	1,636	1,825	1,824	1,820	1,835	2,048	2,046	2,043	2,058	2,288	2,287	2,283	2,299	2,557	2,556	2,552	2,568	2,873	2,871	2,868	2,883
	Amps	6.2	6.2	6.2	6.2	7.1	7.1	7.0	7.1	8.0	8.0	8.0	8.1	9.1	9.1	9.0	9.1	10.2	10.2	10.2	10.3	11.6	11.6	11.6	11.7
	Hi PR	264.7	265.8	267.6	272.1	305.2	306.3	308.1	312.6	347.6	348.7	350.5	355.0	393.2	394.3	396.1	400.6	442.4	443.5	445.3	449.8	494.9	496.0	497.8	502.3
	Lo PR	133.5	135.0	138.2	143.5	141.1	142.6	145.8	151.1	147.7	149.3	152.4	157.8	153.4	154.9	158.1	163.4	158.9	160.4	163.6	168.9	165.8	167.3	170.5	175.8

IDB: Entering Indoor Dry Bulb Temperature
 High and low pressures are measured at the liquid and suction service valves.
 Shaded area reflects AHRI (TVA) conditions
 kW = Total system power
 Amps = outdoor unit amps (comp.+fan)

EXPANDED COOLING DATA — GPGM530***31 LOW STAGE

IDB	AIRFLOW	OUTDOOR AMBIENT TEMPERATURE																																			
		65°F						75°F						85°F						95°F						105°F						115°F					
		59	63	67	71	75	79	59	63	67	71	75	79	59	63	67	71	75	79	59	63	67	71	75	79	59	63	67	71	75	79	59	63	67	71	75	79
																			ENTERING INDOOR WET BULB TEMPERATURE																		
600	MBh	21.5	21.8	22.4	-	-	21.3	21.6	22.2	-	-	20.7	21.0	21.7	-	-	19.7	20.1	20.7	-	-	18.6	18.9	19.5	-	-	17.5	17.8	18.4	-	-						
	S/T	0.63	0.55	0.41	-	-	0.64	0.56	0.41	-	-	0.67	0.58	0.44	-	-	1.00	0.61	0.46	-	-	1.00	0.63	0.48	-	-	1.00	0.68	0.54	-	-						
	ΔT	20.61	18.72	15.19	-	-	20.56	18.67	15.14	-	-	20.82	18.93	15.41	-	-	20.54	18.65	15.12	-	-	20.28	18.39	14.87	-	-	21.47	19.58	16.05	-	-						
	kW	1245	1243	1241	-	-	1398	1396	1394	-	-	1568	1567	1565	-	-	1753	1752	1749	-	-	1960	1958	1956	-	-	2202	2201	2198	-	-						
	Amps	4.66	4.66	4.65	-	-	5.33	5.32	5.31	-	-	6.07	6.06	6.05	-	-	6.87	6.87	6.86	-	-	7.77	7.77	7.75	-	-	8.82	8.82	8.81	-	-						
	Hi PR	248	249	251	-	-	287	288	290	-	-	328	329	331	-	-	372	373	375	-	-	420	421	423	-	-	471	472	473	-	-						
Lo PR	125	126	130	-	-	132	134	137	-	-	139	141	144	-	-	145	146	150	-	-	150	152	155	-	-	157	159	162	-	-							
700	MBh	21.8	22.1	22.7	-	-	21.6	21.9	22.5	-	-	21.0	21.3	22.0	-	-	20.1	20.4	21.0	-	-	18.9	19.2	19.8	-	-	17.8	18.1	18.8	-	-						
	S/T	0.71	0.63	0.48	-	-	0.71	0.63	0.49	-	-	0.74	0.66	0.52	-	-	1.00	0.68	0.54	-	-	1.00	0.70	0.56	-	-	1.00	0.76	0.62	-	-						
	ΔT	19.28	17.39	13.87	-	-	19.23	17.34	13.82	-	-	19.50	17.61	14.08	-	-	19.21	17.32	13.80	-	-	18.96	17.07	13.54	-	-	20.14	18.25	14.73	-	-						
	kW	1254	1253	1250	-	-	1407	1406	1403	-	-	1578	1576	1574	-	-	1762	1761	1759	-	-	1969	1968	1965	-	-	2211	2210	2207	-	-						
	Amps	4.70	4.70	4.69	-	-	5.37	5.36	5.35	-	-	6.11	6.10	6.09	-	-	6.91	6.91	6.90	-	-	7.81	7.81	7.79	-	-	8.86	8.86	8.85	-	-						
	Hi PR	250	251	253	-	-	289	291	292	-	-	330	332	333	-	-	375	376	377	-	-	422	423	425	-	-	473	474	476	-	-						
Lo PR	127	129	132	-	-	135	136	139	-	-	141	143	146	-	-	147	148	152	-	-	152	154	157	-	-	159	161	164	-	-							
800	MBh	22.2	22.5	23.1	-	-	22.0	22.3	22.9	-	-	21.4	21.7	22.4	-	-	20.5	20.8	21.4	-	-	19.3	19.6	20.2	-	-	18.2	18.5	19.1	-	-						
	S/T	0.75	0.67	0.52	-	-	0.75	0.67	0.53	-	-	1.00	0.70	0.56	-	-	1.00	0.72	0.58	-	-	1.00	0.74	0.60	-	-	1.00	0.80	0.65	-	-						
	ΔT	18.19	16.31	12.78	-	-	18.14	16.25	12.73	-	-	18.41	16.52	12.99	-	-	18.12	16.23	12.71	-	-	17.87	15.98	12.46	-	-	19.05	17.17	13.64	-	-						
	kW	1261	1260	1258	-	-	1414	1413	1411	-	-	1585	1584	1581	-	-	1770	1769	1766	-	-	1976	1975	1973	-	-	2219	2217	2215	-	-						
	Amps	4.73	4.73	4.72	-	-	5.40	5.39	5.38	-	-	6.14	6.14	6.13	-	-	6.95	6.94	6.93	-	-	7.84	7.84	7.83	-	-	8.90	8.89	8.88	-	-						
	Hi PR	253	254	255	-	-	292	293	295	-	-	333	334	336	-	-	377	378	380	-	-	425	426	427	-	-	475	476	478	-	-						
Lo PR	129	131	134	-	-	137	138	142	-	-	144	145	148	-	-	149	151	154	-	-	155	156	159	-	-	162	163	166	-	-							

600	MBh	21.5	21.8	22.4	23.4	-	21.3	21.6	22.2	23.2	-	-	20.7	21.0	21.7	22.7	19.8	20.1	20.7	21.7	-	-	18.6	18.9	19.5	20.5	-	-	17.5	17.8	18.4	19.4		
	S/T	0.77	0.69	0.54	0.4	-	0.78	0.70	0.55	0.4	-	-	1.00	0.72	0.58	0.4	1.00	0.74	0.60	0.4	-	-	1.00	0.77	0.62	0.5	1.00	1.00	0.68	0.5	1.00	0.75	0.6	
	ΔT	24.76	22.87	19.34	15.7	-	24.71	22.82	19.29	15.6	-	-	24.97	23.08	19.56	15.9	24.69	22.80	19.27	15.6	-	-	24.44	22.55	19.02	15.4	25.62	23.73	20.20	16.6	25.62	23.73	20.20	16.6
	kW	1244	1242	1240	1252	-	1397	1395	1393	1405	-	-	1567	1566	1564	1575	1752	1751	1748	1760	-	-	1959	1957	1955	1967	2201	2200	2197	2209	2201	2200	2197	2209
	Amps	4.66	4.65	4.64	4.7	-	5.32	5.32	5.31	5.4	-	-	6.07	6.06	6.05	6.1	6.87	6.86	6.85	6.9	-	-	7.77	7.76	7.75	7.8	8.82	8.81	8.80	8.9	8.82	8.81	8.80	8.9
	Hi PR	248	249	251	255.2	-	287	288	290	294.4	-	-	328	329	331	335.4	372	373	375	379.6	-	-	420	421	423	427.2	471	472	474	478.0	471	472	474	478.0
Lo PR	125	126	130	135.0	-	133	134	137	142.6	-	-	139	141	144	149.2	145	146	150	154.9	-	-	150	152	155	160.4	157	159	162	167.3	157	159	162	167.3	
700	MBh	21.8	22.1	22.7	23.7	-	21.6	21.9	22.6	23.5	-	-	21.0	21.4	22.0	23.0	20.1	20.4	21.0	22.0	-	-	18.9	19.2	19.8	20.8	17.8	18.1	18.8	19.7	17.8	18.1	18.8	19.7
	S/T	0.85	0.76	0.62	0.5	-	1.00	0.77	0.63	0.5	-	-	1.00	0.80	0.65	0.5	1.00	0.82	0.67	0.5	-	-	1.00	0.84	0.70	0.5	1.00	1.00	0.75	0.6	1.00	1.00	0.75	0.6
	ΔT	23.44	21.55	18.02	14.4	-	23.38	21.49	17.97	14.3	-	-	23.65	21.76	18.23	14.6	23.36	21.48	17.95	14.3	-	-	23.11	21.22	17.70	14.0	24.29	22.41	18.88	15.2	24.29	22.41	18.88	15.2
	kW	1253	1252	1249	1261	-	1406	1405	1402	1414	-	-	1577	1575	1573	1584	1761	1760	1758	1769	-	-	1968	1967	1964	1976	2210	2209	2206	2218	2210	2209	2206	2218
	Amps	4.70	4.69	4.68	4.7	-	5.36	5.36	5.35	5.4	-	-	6.11	6.10	6.09	6.1	6.91	6.89	6.89	6.9	-	-	7.81	7.80	7.79	7.8	8.86	8.85	8.84	8.9	8.86	8.85	8.84	8.9
	Hi PR	250	252	253	257.6	-	290	291	292	296.8	-	-	331	332	333	337.8	375	376	378	382.0	-	-	422	424	425	429.6	473	474	476	480.4	473	474	476	480.4
Lo PR	127	129	132	137.0	-	135	136	139	144.7	-	-	141	143	146	151.3	147	148	152	157.0	-	-	152	154	157	162.5	159	161	164	169.4	159	161	164	169.4	
800	MBh	22.2	22.5	23.1	24.1	-	22.0	22.3	22.9	23.9	-	-	21.4	21.7	22.4	23.4	20.5	20.8	21.4	22.4	-	-	19.3	19.6	20.2	21.2	18.2	18.5	19.2	20.1	18.2	18.5	19.2	20.1
	S/T	0.88	0.80	0.66	0.5	-	1.00	0.81	0.67	0.5	-	-	1.00	0.84	0.69	0.5	1.00	0.86	0.71	0.6	-	-	1.00	0.88	0.74	0.6	1.00	1.00	0.79	0.6	1.00	1.00	0.79	0.6
	ΔT	22.35	20.46	16.93	13.3	-	22.30	20.41	16.88	13.2	-	-	22.56	20.67	17.15	13.5	22.28	20.39	16.86	13.2	-	-	22.02	20.14	16.61	13.0	23.21	21.32	17.79	14.1	23.21	21.32	17.79	14.1
	kW	1260	1259	1257	1268	-	1413	1412	1410	1421	-	-	1584	1583	1580	1592	1769	1768	1765	1777	-	-	1975	1974	1972	1983	2218	2216	2214	2226	2218	2216	2214	2226
	Amps	4.73	4.73	4.71	4.8	-	5.40	5.39	5.38	5.4	-	-	6.14	6.13	6.12	6.2	6.94	6.94	6.93	7.0	-	-	7.84	7.83	7.82	7.9	8.89	8.89	8.88	8.9	8.89	8.89	8.88	8.9
	Hi PR	253	254	256	260.0	-	292	293	295	299.1	-	-	333	334	336	340.2	377	378	380	384.3	-	-	425	426	428	432.0	476	477	478	482.8	476	477	478	482.8
Lo PR	129	131	134	139.4	-	137	138	142	147.0	-	-	144	145	148	153.7	149	151	154	159.3	-	-	155	156	160	164.8	162	163	166	171.8	162	163	166	171.8	

IDB: Entering Indoor Dry Bulb Temperature
 High and low pressures are measured at the liquid and suction service valves.
 Shaded area reflects ACCA (TVA) conditions
 kW = Total system power
 Amps = outdoor unit amps (comp.+fan)

IDB	AIRFLOW	OUTDOOR AMBIENT TEMPERATURE																								
		65°F				75°F				85°F				95°F				105°F				115°F				
		59	63	67	71	59	63	67	71	59	63	67	71	59	63	67	71	59	63	67	71	59	63	67	71	
600	MBh	21.6	21.9	22.2	22.9	23.8	21.4	21.7	22.3	23.3	20.8	21.1	21.8	22.8	19.9	20.2	20.8	21.8	18.7	19.0	19.6	20.6	17.6	17.9	18.6	19.5
	S/T	1.00	0.82	0.68	0.5	0.5	1.00	0.83	0.68	0.5	1.00	0.86	0.71	0.6	1.00	1.00	1.00	0.73	1.00	1.00	1.00	0.76	1.00	1.00	1.00	0.81
	ΔT	28.94	27.05	23.53	19.9	18.5	28.89	27.00	23.47	19.8	29.15	27.27	23.74	20.1	28.87	26.98	23.45	19.8	28.62	26.73	23.20	19.5	29.80	27.91	24.38	20.7
	kW	1244	1243	1241	1252	1252	1397	1396	1394	1405	1568	1567	1564	1576	1753	1752	1749	1761	1959	1958	1956	1967	2202	2200	2198	2210
	Amps	4.66	4.66	4.64	4.7	4.7	5.33	5.32	5.31	5.4	6.07	6.06	6.05	6.1	6.87	6.87	6.86	6.9	7.77	7.76	7.75	7.8	8.82	8.82	8.81	8.9
80	Hi PR	249	250	251	255.7	255.7	288	289	291	294.8	329	330	332	335.9	373	374	376	380.0	421	422	423	427.7	471	472	474	478.5
	Lo PR	125	127	130	135.5	135.5	133	135	138	143.1	140	141	144	149.8	145	147	150	155.4	151	152	156	161.0	158	159	163	167.9
	MBh	21.9	22.2	22.9	23.8	24.2	21.7	22.0	22.7	23.6	21.2	21.5	22.1	23.1	20.2	20.5	21.1	22.1	19.0	19.3	20.0	20.9	17.9	18.2	18.9	19.9
	S/T	1.00	0.90	0.75	0.6	0.6	1.00	0.90	0.76	0.6	1.00	0.93	0.79	0.6	1.00	1.00	1.00	0.81	1.00	1.00	1.00	0.83	1.00	1.00	1.00	0.89
	ΔT	27.62	25.73	22.20	18.5	18.5	27.56	25.68	22.15	18.5	27.83	25.94	22.41	18.8	27.55	25.66	22.13	18.5	27.29	25.40	21.88	18.2	28.48	26.59	23.06	19.4
800	kW	1254	1252	1250	1262	1269	1407	1405	1403	1415	1577	1576	1574	1585	1762	1761	1758	1770	1969	1967	1965	1977	2211	2210	2207	2219
	Amps	4.70	4.70	4.68	4.7	4.7	5.37	5.36	5.35	5.4	6.11	6.10	6.09	6.1	6.91	6.91	6.90	6.9	7.81	7.80	7.79	7.8	8.86	8.86	8.85	8.9
	Hi PR	251	252	254	258.1	258.1	290	291	293	297.3	331	332	334	338.3	375	376	378	382.5	423	424	426	430.1	474	475	477	480.9
	Lo PR	128	129	132	137.6	137.6	135	137	140	145.2	142	143	147	151.9	147	149	152	157.5	153	155	158	163.0	160	161	165	170.0
	MBh	22.3	22.6	23.3	24.2	24.2	22.1	22.4	23.1	24.0	21.6	21.9	22.5	23.5	20.6	20.9	21.5	22.5	19.4	19.7	20.4	21.3	18.3	18.6	19.3	20.3
85	S/T	1.00	0.94	0.79	0.6	0.6	1.00	0.94	0.80	0.6	1.00	1.00	0.83	0.7	1.00	1.00	1.00	0.85	1.00	1.00	1.00	0.87	1.00	1.00	1.00	0.92
	ΔT	26.53	24.64	21.11	17.5	17.5	26.48	24.59	21.06	17.4	26.74	24.85	21.33	17.7	26.46	24.57	21.04	17.4	26.21	24.32	20.79	17.1	27.39	25.50	21.97	18.3
	kW	1261	1260	1257	1269	1269	1414	1413	1410	1422	1585	1584	1581	1593	1770	1769	1766	1778	1976	1975	1972	1984	2218	2217	2215	2226
	Amps	4.73	4.73	4.72	4.8	4.8	5.40	5.39	5.38	5.4	6.14	6.14	6.13	6.2	6.95	6.94	6.93	7.0	7.84	7.84	7.83	7.9	8.90	8.89	8.88	8.9
	Hi PR	253	254	256	260.4	260.4	292	294	295	299.6	333	335	336	340.6	378	379	380	384.8	425	426	428	432.4	476	477	479	483.2
600	Lo PR	130	131	135	139.9	139.9	138	139	142	147.6	144	146	149	154.2	150	151	155	159.9	155	157	160	165.4	162	164	167	172.3
	MBh	22.0	22.3	22.9	23.9	24.2	21.8	22.1	22.7	23.7	21.2	21.5	22.1	23.1	20.2	20.5	21.2	22.2	19.1	19.4	20.0	21.0	18.0	18.3	18.9	19.9
	S/T	1.00	0.93	0.79	0.6	0.6	1.00	1.00	0.79	0.6	1.00	1.00	0.82	0.7	1.00	1.00	1.00	0.84	1.00	1.00	1.00	0.86	1.00	1.00	1.00	0.8
	ΔT	32.65	30.76	27.23	23.6	23.6	32.60	30.71	27.18	23.5	32.86	30.97	27.45	23.8	32.58	30.69	27.16	23.5	32.33	30.44	26.91	23.3	33.51	31.62	28.09	24.4
	kW	1247	1246	1244	1255	1255	1400	1399	1397	1408	1571	1570	1567	1579	1756	1755	1752	1764	1962	1961	1959	1970	2205	2203	2201	2213
700	Amps	4.67	4.67	4.66	4.7	4.7	5.34	5.33	5.32	5.4	6.08	6.08	6.07	6.1	6.89	6.88	6.87	6.9	7.78	7.78	7.77	7.8	8.84	8.83	8.82	8.9
	Hi PR	250	251	253	256.8	256.8	289	290	292	296.0	330	331	333	337.0	374	375	377	381.2	422	423	424	428.8	473	474	475	479.6
	Lo PR	127	129	132	137.4	137.4	135	136	140	145.0	142	143	146	151.7	147	149	152	157.3	153	154	158	162.8	160	161	164	169.8
	MBh	22.3	22.6	23.2	24.2	24.2	22.1	22.4	23.0	24.0	21.5	21.8	22.5	23.4	20.6	20.9	21.5	22.5	19.4	19.7	20.3	21.3	18.3	18.6	19.2	20.2
	S/T	1.00	1.00	0.86	0.7	0.7	1.00	1.00	0.87	0.7	1.00	1.00	0.89	0.7	1.00	1.00	1.00	0.92	1.00	1.00	1.00	0.8	1.00	1.00	1.00	0.8
800	ΔT	31.32	29.44	25.91	22.3	22.3	31.27	29.38	25.86	22.2	31.54	29.65	26.12	22.5	31.25	29.36	25.84	22.2	31.00	29.11	25.59	21.9	32.18	30.29	26.77	23.1
	kW	1257	1255	1253	1264	1264	1410	1408	1406	1417	1580	1579	1577	1588	1765	1764	1761	1773	1972	1970	1968	1979	2214	2213	2210	2222
	Amps	4.71	4.71	4.70	4.7	4.7	5.38	5.37	5.36	5.4	6.12	6.12	6.11	6.2	6.93	6.92	6.91	7.0	7.82	7.82	7.81	7.9	8.88	8.87	8.86	8.9
	Hi PR	252	253	255	259.3	259.3	291	292	294	298.4	332	333	335	339.4	376	378	379	383.6	424	425	427	431.2	475	476	478	482.1
	Lo PR	129	131	134	139.5	139.5	137	139	142	147.1	144	145	148	153.8	149	151	154	159.4	155	156	160	164.9	162	163	167	171.8
800	MBh	22.7	23.0	23.6	24.6	24.6	22.5	22.8	23.4	24.4	21.9	22.2	22.9	23.8	20.9	21.3	21.9	22.9	19.8	20.1	20.7	21.7	18.7	19.0	19.6	20.6
	S/T	1.00	1.00	0.90	0.7	0.7	1.00	1.00	0.91	0.8	1.00	1.00	0.93	0.8	1.00	1.00	1.00	0.95	1.00	1.00	1.00	0.8	1.00	1.00	1.00	0.9
	ΔT	30.24	28.35	24.82	21.2	21.2	30.19	28.30	24.77	21.1	30.45	28.56	25.04	21.4	30.17	28.28	24.75	21.1	29.91	28.02	24.50	20.8	31.10	29.21	25.68	22.0
	kW	1264	1263	1260	1272	1272	1417	1416	1413	1425	1588	1587	1584	1596	1773	1771	1769	1781	1979	1978	1975	1987	2221	2220	2218	2229
	Amps	4.75	4.74	4.73	4.8	4.8	5.41	5.41	5.40	5.4	6.15	6.15	6.14	6.2	6.96	6.95	6.94	7.0	7.86	7.85	7.84	7.9	8.91	8.90	8.89	8.9
800	Hi PR	254	256	257	261.6	261.6	294	295	296	300.8	335	336	337	341.8	379	380	382	386.0	426	428	429	433.6	477	478	480	484.4
	Lo PR	132	133	136	141.8	141.8	139	141	144	149.4	146	148	151	156.1	152	153	156	161.7	157	159	162	167.3	164	166	169	174.2

IDB: Entering Indoor Dry Bulb Temperature
 High and low pressures are measured at the liquid and suction service valves.
 Shaded area reflects AHRI (TVA) conditions
 kW = Total system power
 Amps = outdoor unit amps (comp.+fan)

EXPANDED COOLING DATA — GPGM530***31 HIGH STAGE

IDB	AIRFLOW	OUTDOOR AMBIENT TEMPERATURE												ENTERING INDOOR WET BULB TEMPERATURE											
		65°F				75°F				85°F				95°F				105°F				115°F			
		59	63	67	71	59	63	67	71	59	63	67	71	59	63	67	71	59	63	67	71	59	63	67	71
70	MBh	29.8	30.2	31.1	-	29.6	30.0	30.9	-	28.8	29.2	30.1	-	27.4	27.8	28.7	-	25.8	26.2	27.1	-	24.3	24.7	25.6	-
	S/T	0.61	0.53	0.39	-	0.61	0.53	0.39	-	0.64	0.56	0.42	-	0.66	0.58	0.44	-	1.00	0.60	0.46	-	1.00	0.66	0.52	-
	ΔT	21.52	19.56	15.91	-	21.47	19.51	15.85	-	21.74	19.78	16.13	-	21.45	19.49	15.83	-	21.18	19.23	15.57	-	22.41	20.45	16.80	-
	kW	1977	1975	1971	-	2220	2218	2214	-	2492	2490	2486	-	2785	2784	2779	-	3114	3112	3108	-	3499	3497	3493	-
	Amps	7.40	7.40	7.38	-	8.46	8.45	8.44	-	9.62	9.63	9.62	-	10.92	10.91	10.89	-	12.35	12.34	12.32	-	14.02	14.01	13.99	-
	Hi PR	259	260	262	-	300	301	303	-	343	344	346	-	389	390	392	-	439	440	442	-	492	493	495	-
Lo PR	121	123	126	-	129	130	133	-	135	137	140	-	141	142	145	-	146	148	151	-	153	154	157	-	
800	MBh	30.3	30.7	31.6	-	30.0	30.5	31.4	-	29.3	29.7	30.6	-	27.9	28.3	29.2	-	26.3	26.7	27.6	-	24.8	25.2	26.1	-
	S/T	0.69	0.61	0.47	-	0.70	0.62	0.48	-	0.72	0.64	0.50	-	0.74	0.66	0.52	-	1.00	0.69	0.55	-	1.00	0.74	0.60	-
	ΔT	19.98	18.02	14.37	-	19.93	17.97	14.32	-	20.20	18.25	14.59	-	19.91	17.95	14.30	-	19.65	17.69	14.03	-	20.87	18.91	15.26	-
	kW	1993	1991	1987	-	2237	2235	2231	-	2508	2506	2502	-	2802	2800	2796	-	3130	3128	3124	-	3515	3513	3509	-
	Amps	7.48	7.47	7.45	-	8.53	8.52	8.51	-	9.71	9.71	9.69	-	10.99	10.98	10.96	-	12.42	12.41	12.39	-	14.09	14.08	14.07	-
	Hi PR	262	263	265	-	303	304	306	-	346	347	349	-	392	393	395	-	442	443	445	-	495	496	498	-
Lo PR	123	125	128	-	131	132	136	-	137	139	142	-	143	144	147	-	148	150	153	-	155	156	160	-	
1100	MBh	30.9	31.3	32.2	-	30.6	31.1	32.0	-	29.9	30.3	31.2	-	28.5	28.9	29.8	-	26.9	27.3	28.2	-	25.4	25.8	26.7	-
	S/T	0.73	0.65	0.51	-	0.74	0.66	0.52	-	0.76	0.68	0.54	-	1.00	0.70	0.56	-	1.00	0.73	0.59	-	1.00	0.78	0.64	-
	ΔT	18.75	16.79	13.13	-	18.69	16.73	13.08	-	18.97	17.01	13.36	-	18.67	16.71	13.06	-	18.41	16.45	12.80	-	19.64	17.68	14.02	-
	kW	2007	2005	2000	-	2250	2248	2244	-	2521	2519	2515	-	2815	2813	2809	-	3143	3141	3137	-	3528	3526	3522	-
	Amps	7.53	7.52	7.51	-	8.59	8.58	8.56	-	9.77	9.76	9.74	-	11.05	11.04	11.02	-	12.48	12.47	12.45	-	14.15	14.14	14.12	-
	Hi PR	264	266	267	-	305	307	308	-	348	349	351	-	395	396	398	-	444	446	447	-	498	499	501	-
Lo PR	126	128	131	-	133	135	138	-	140	141	145	-	145	147	150	-	151	152	155	-	158	159	162	-	

75	MBh	29.8	30.3	31.2	32.5	29.6	30.0	30.9	32.2	28.8	29.2	30.1	31.5	27.4	27.9	28.8	30.1	25.8	26.2	27.1	28.5	24.3	24.7	25.6	27.0
	S/T	0.74	0.66	0.52	0.4	0.75	0.67	0.53	0.4	1.00	0.69	0.55	0.4	1.00	0.71	0.57	0.4	1.00	0.74	0.60	0.4	1.00	0.79	0.65	0.6
	ΔT	25.82	23.87	20.21	16.4	25.77	23.81	20.16	16.4	26.04	24.09	20.43	16.6	25.75	23.79	20.14	16.4	25.49	23.53	19.88	16.1	26.71	24.76	21.10	17.3
	kW	1975	1974	1969	1988	2219	2217	2213	2231	2490	2488	2484	2503	2784	2782	2778	2796	3112	3110	3106	3125	3497	3495	3491	3510
	Amps	7.40	7.39	7.37	7.5	8.45	8.45	8.43	8.5	9.64	9.63	9.61	9.7	10.91	10.90	10.89	11.0	12.34	12.33	12.31	12.4	14.01	14.01	13.99	14.1
	Hi PR	259	260	262	266.7	300	301	303	307.6	343	344	346	350.5	389	390	392	396.8	439	440	442	446.6	492	493	495	499.7
Lo PR	121	123	126	131.1	129	130	133	138.5	135	137	140	145.0	141	142	145	150.4	146	148	151	155.8	153	154	157	162.6	
950	MBh	30.3	30.7	31.6	33.0	30.1	30.5	31.4	32.7	29.3	29.7	30.6	32.0	27.9	28.4	29.2	30.6	26.3	26.7	27.6	29.0	24.8	25.2	26.1	27.5
	S/T	0.82	0.74	0.60	0.5	0.83	0.75	0.61	0.5	1.00	0.78	0.64	0.5	1.00	0.80	0.66	0.5	1.00	0.82	0.68	0.5	1.00	1.00	0.73	0.6
	ΔT	24.29	22.33	18.67	14.9	24.23	22.27	18.62	14.8	24.51	22.55	18.89	15.1	24.21	22.25	18.60	14.8	23.95	21.99	18.34	14.6	25.18	23.22	19.56	15.8
	kW	1992	1990	1986	2004	2235	2233	2229	2248	2507	2505	2500	2519	2800	2798	2794	2813	3129	3127	3123	3141	3514	3512	3508	3526
	Amps	7.47	7.46	7.44	7.5	8.53	8.52	8.50	8.6	9.71	9.70	9.68	9.8	10.98	10.98	10.96	11.0	12.41	12.40	12.38	12.5	14.09	14.08	14.06	14.1
	Hi PR	262	263	265	269.5	303	304	306	310.5	346	347	349	353.4	392	393	395	399.6	442	443	445	449.4	495	496	498	502.6
Lo PR	124	125	128	133.3	131	132	136	140.7	137	139	142	147.2	143	144	148	152.7	148	150	153	158.1	155	157	160	164.8	
1100	MBh	30.9	31.4	32.2	33.6	30.7	31.1	32.0	33.3	29.9	30.3	31.2	32.6	28.5	29.0	29.9	31.2	26.9	27.3	28.2	29.6	25.4	25.8	26.7	28.1
	S/T	0.86	0.78	0.64	0.5	1.00	0.79	0.65	0.5	1.00	0.82	0.68	0.5	1.00	0.84	0.70	0.5	1.00	0.86	0.72	0.6	1.00	1.00	0.77	0.6
	ΔT	23.05	21.09	17.44	13.7	23.00	21.04	17.38	13.6	23.27	21.31	17.66	13.9	22.98	21.02	17.36	13.6	22.71	20.76	17.10	13.3	23.94	21.98	18.33	14.5
	kW	2005	2003	1999	2017	2248	2246	2242	2261	2520	2518	2514	2532	2813	2812	2807	2826	3142	3140	3136	3154	3527	3525	3521	3539
	Amps	7.53	7.52	7.50	7.6	8.58	8.58	8.56	8.6	9.76	9.76	9.74	9.8	11.04	11.03	11.01	11.1	12.47	12.46	12.44	12.5	14.14	14.13	14.12	14.2
	Hi PR	265	266	268	272.2	306	307	309	313.2	349	350	352	356.1	395	396	398	402.3	445	446	448	452.1	498	499	501	505.3
Lo PR	126	128	131	135.9	133	135	138	143.3	140	141	145	149.7	145	147	150	155.2	151	152	155	160.6	158	159	162	167.4	

IDB: Entering Indoor Dry Bulb Temperature
 High and low pressures are measured at the liquid and suction service valves.
 Shaded area reflects ACCA (TVA) conditions
 kW = Total system power
 Amps = outdoor unit amps (comp. + fan)

EXPANDED COOLING DATA — GPGM530***31 HIGH STAGE (CONT.)

IDB	AIRFLOW	OUTDOOR AMBIENT TEMPERATURE												ENTERING INDOOR WET BULB TEMPERATURE											
		65°F				75°F				85°F				95°F				105°F				115°F			
		59	63	67	71	59	63	67	71	59	63	67	71	59	63	67	71	59	63	67	71	59	63	67	71
80	MBh	30.0	30.4	31.3	32.7	29.7	30.1	31.0	32.4	28.9	29.4	30.3	31.6	27.6	28.0	28.9	30.3	26.0	26.4	27.3	28.6	24.5	24.9	25.8	27.1
	S/T	0.87	0.79	0.65	0.5	1.00	0.80	0.66	0.5	1.00	0.82	0.68	0.5	1.00	0.84	0.70	0.6	1.00	1.00	0.73	0.6	1.00	1.00	0.78	0.6
	ΔT	30.16	28.20	24.54	20.8	30.10	28.15	24.49	20.7	30.38	28.42	24.77	21.0	30.08	28.13	24.47	20.7	29.82	27.86	24.21	20.4	31.05	29.09	25.43	21.6
	kW	1977	1975	1971	1989	2220	2218	2214	2232	2491	2489	2485	2504	2785	2783	2779	2798	3113	3112	3107	3126	3499	3497	3492	3511
	Amps	7.40	7.39	7.38	7.5	8.46	8.45	8.43	8.5	9.64	9.63	9.61	9.7	10.92	10.91	10.89	11.0	12.35	12.34	12.32	12.4	14.02	14.01	13.99	14.1
	Hi PR	260	261	263	267.2	301	302	304	308.1	344	345	347	351.0	390	391	393	397.2	440	441	443	447.1	493	494	496	500.2
	Lo PR	122	123	126	131.6	129	131	134	139.0	136	137	140	145.5	141	143	146	151.0	147	148	151	156.4	153	155	158	163.1
	MBh	30.5	30.9	31.8	33.2	30.2	30.6	31.5	32.9	29.4	29.9	30.7	32.1	28.1	28.5	29.4	30.8	26.4	26.9	27.8	29.1	24.9	25.4	26.3	27.6
	S/T	1.00	0.87	0.73	0.6	1.00	0.88	0.74	0.6	1.00	0.91	0.77	0.6	1.00	0.93	0.79	0.6	1.00	1.00	0.81	0.7	1.00	1.00	0.86	0.7
	ΔT	28.62	26.66	23.01	19.2	28.56	26.61	22.95	19.2	28.84	26.88	23.23	19.4	28.54	26.59	22.93	19.1	28.28	26.33	22.67	18.9	29.51	27.55	23.90	20.1
80	kW	1993	1991	1987	2006	2236	2234	2230	2249	2508	2506	2502	2520	2802	2800	2796	2814	3130	3128	3124	3142	3515	3513	3509	3528
	Amps	7.47	7.47	7.45	7.5	8.53	8.52	8.51	8.6	9.71	9.70	9.69	9.8	10.99	10.98	10.96	11.0	12.42	12.41	12.39	12.5	14.09	14.08	14.06	14.1
	Hi PR	262	264	265	270.0	303	305	306	310.9	346	347	349	353.8	393	394	396	400.1	442	444	445	449.9	496	497	499	503.0
	Lo PR	124	126	129	133.9	131	133	136	141.3	138	139	143	147.7	143	145	148	153.2	149	150	153	158.6	156	157	160	165.3
	MBh	31.1	31.5	32.4	33.8	30.8	31.2	32.1	33.5	30.0	30.5	31.4	32.7	28.7	29.1	30.0	31.4	27.1	27.5	28.4	29.7	25.6	26.0	26.9	28.2
	S/T	1.00	0.91	0.77	0.6	1.00	0.92	0.78	0.6	1.00	0.95	0.81	0.7	1.00	1.00	0.83	0.7	1.00	1.00	0.85	0.7	1.00	1.00	0.90	0.8
	ΔT	27.38	25.42	21.77	18.0	27.33	25.37	21.72	17.9	27.60	25.65	21.99	18.2	27.31	25.35	21.70	17.9	27.05	25.09	21.43	17.6	28.27	26.31	22.66	18.9
	kW	2006	2004	2000	2019	2249	2248	2243	2262	2521	2519	2515	2533	2815	2813	2809	2827	3143	3141	3137	3156	3528	3526	3522	3541
	Amps	7.53	7.52	7.51	7.6	8.59	8.58	8.56	8.6	9.77	9.76	9.74	9.8	11.05	11.04	11.02	11.1	12.47	12.47	12.45	12.5	14.15	14.14	14.12	14.2
	Hi PR	265	266	268	272.7	306	307	309	313.6	349	350	352	356.6	395	396	398	402.8	445	446	448	452.6	498	499	501	505.7
Lo PR	127	128	131	136.4	134	136	139	143.8	141	142	145	150.3	146	147	151	155.8	151	153	156	161.2	158	160	163	167.9	
85	MBh	30.5	30.9	31.8	33.2	30.2	30.6	31.5	32.9	29.4	29.9	30.8	32.1	28.1	28.5	29.4	30.8	26.5	26.9	27.8	29.1	25.0	25.4	26.3	27.6
	S/T	1.00	0.90	0.75	0.6	1.00	0.90	0.76	0.6	1.00	1.00	0.79	0.6	1.00	1.00	0.81	0.7	1.00	1.00	0.83	0.7	1.00	1.00	1.00	0.7
	ΔT	34.00	32.04	28.39	24.6	33.95	31.99	28.33	24.5	34.22	32.26	28.61	24.8	33.93	31.97	28.31	24.5	33.66	31.71	28.05	24.3	34.89	32.93	29.28	25.5
	kW	1981	1979	1975	1994	2225	2223	2218	2237	2496	2494	2490	2509	2790	2788	2784	2802	3118	3116	3112	3131	3503	3501	3497	3516
	Amps	7.42	7.41	7.40	7.5	8.48	8.47	8.45	8.5	9.66	9.65	9.63	9.7	10.94	10.93	10.91	11.0	12.37	12.36	12.34	12.4	14.04	14.03	14.01	14.1
	Hi PR	261	262	264	268.4	302	303	305	309.3	345	346	348	352.2	391	392	394	398.5	441	442	444	448.3	494	495	497	501.4
	Lo PR	124	125	128	133.4	131	133	136	140.8	138	139	142	147.3	143	145	148	152.8	148	150	153	158.2	155	157	160	164.9
	MBh	31.0	31.4	32.3	33.7	30.7	31.1	32.0	33.4	29.9	30.4	31.2	32.6	28.6	29.0	29.9	31.3	26.9	27.4	28.3	29.6	25.4	25.9	26.8	28.1
	S/T	1.00	0.98	0.84	0.7	1.00	0.99	0.85	0.7	1.00	1.00	0.87	0.7	1.00	1.00	0.89	0.7	1.00	1.00	0.91	0.8	1.00	1.00	1.00	0.8
	ΔT	32.46	30.50	26.85	23.1	32.41	30.45	26.80	23.0	32.68	30.72	27.07	23.3	32.39	30.43	26.78	23.0	32.13	30.17	26.51	22.7	33.35	31.39	27.74	24.0
kW	1998	1996	1992	2010	2241	2239	2235	2254	2512	2511	2506	2525	2806	2804	2800	2819	3135	3133	3128	3147	3520	3518	3514	3532	
Amps	7.49	7.49	7.47	7.5	8.55	8.54	8.53	8.6	9.73	9.72	9.71	9.8	11.01	11.00	10.98	11.1	12.44	12.43	12.41	12.5	14.11	14.10	14.09	14.2	
Hi PR	264	265	267	271.2	305	306	308	312.2	348	349	351	355.1	394	395	397	401.3	444	445	447	451.1	497	498	500	504.3	
Lo PR	126	127	130	135.7	133	135	138	143.1	140	141	144	149.6	145	147	150	155.0	151	152	155	160.4	157	159	162	167.2	
MBh	31.6	32.0	32.9	34.3	31.3	31.7	32.6	34.0	30.5	31.0	31.9	33.2	29.2	29.6	30.5	31.9	27.6	28.0	28.9	30.2	26.1	26.5	27.4	28.7	
S/T	1.00	1.00	0.88	0.7	1.00	1.00	0.89	0.7	1.00	1.00	0.91	0.8	1.00	1.00	0.93	0.8	1.00	1.00	0.95	0.8	1.00	1.00	1.00	0.9	
ΔT	31.22	29.27	25.61	21.8	31.17	29.21	25.56	21.8	31.45	29.49	25.83	22.0	31.15	29.19	25.54	21.8	30.89	28.93	25.28	21.5	32.11	30.16	26.50	22.7	
kW	2011	2009	2005	2023	2254	2252	2248	2267	2526	2524	2520	2538	2819	2817	2813	2832	3148	3146	3142	3160	3533	3531	3527	3545	
Amps	7.55	7.54	7.53	7.6	8.61	8.60	8.58	8.7	9.79	9.78	9.76	9.8	11.07	11.06	11.04	11.1	12.49	12.49	12.47	12.5	14.17	14.16	14.14	14.2	
Hi PR	266	268	269	273.9	307	309	310	314.9	350	351	353	357.8	397	398	399	404.0	446	447	449	453.8	499	501	502	507.0	
Lo PR	128	130	133	138.2	136	137	140	145.6	142	144	147	152.1	148	149	152	157.6	153	155	158	163.0	160	161	165	169.7	

IDB: Entering Indoor Dry Bulb Temperature
 High and low pressures are measured at the liquid and suction service valves.
 Shaded area reflects AHRI (TVA) conditions
 kW = Total system power
 Amps = outdoor unit amps (comp.+fan)

EXPANDED COOLING DATA — GPGM536***31 LOW STAGE

IDB	AIRFLOW	OUTDOOR AMBIENT TEMPERATURE																																			
		65°F						75°F						85°F						95°F						105°F						115°F					
		59	63	67	71	75	79	59	63	67	71	75	79	59	63	67	71	75	79	59	63	67	71	75	79	59	63	67	71	75	79	59	63	67	71	75	79
																			ENTERING INDOOR WET BULB TEMPERATURE																		
70	MBh	26.0	26.3	27.1	-	-	25.1	25.4	26.2	-	-	23.9	24.3	25.0	-	-	22.5	22.8	23.6	-	-	22.5	22.8	23.6	-	-	21.2	21.5	22.3	-	-	21.2	21.5	22.3	-	-	
	S/T	0.64	0.56	0.41	-	-	1.00	0.59	0.44	-	-	1.00	0.61	0.46	-	-	1.00	1.00	0.49	-	-	1.00	1.00	0.49	-	-	1.00	1.00	0.54	-	-	1.00	1.00	0.54	-	-	
	ΔT	19.40	17.63	14.33	-	-	19.60	17.83	14.53	-	-	19.34	17.56	14.26	-	-	19.10	17.33	14.02	-	-	19.10	17.33	14.02	-	-	20.21	18.44	15.13	-	-	20.21	18.44	15.13	-	-	
	kW	1534	1532	1529	-	-	1908	1907	1904	-	-	2122	2120	2117	-	-	2360	2359	2356	-	-	2360	2359	2356	-	-	2640	2639	2636	-	-	2640	2639	2636	-	-	
	Amps	5.45	5.44	5.43	-	-	7.08	7.07	7.06	-	-	8.01	8.00	7.99	-	-	9.04	9.04	9.03	-	-	9.04	9.04	9.03	-	-	10.26	10.26	10.24	-	-	10.26	10.26	10.24	-	-	
	Hi PR	236	237	239	-	-	312	313	315	-	-	354	355	357	-	-	400	401	402	-	-	400	401	402	-	-	448	449	451	-	-	448	449	451	-	-	
Lo PR	135	136	140	-	-	143	145	148	-	-	156	158	161	-	-	162	164	167	-	-	162	164	167	-	-	170	171	175	-	-	170	171	175	-	-		
825	MBh	26.4	26.8	27.5	-	-	25.5	25.8	26.6	-	-	24.3	24.7	25.4	-	-	22.9	23.2	24.0	-	-	22.9	23.2	24.0	-	-	21.6	21.9	22.7	-	-	21.6	21.9	22.7	-	-	
	S/T	0.72	0.64	0.49	-	-	1.00	0.65	0.50	-	-	1.00	0.69	0.55	-	-	1.00	1.00	0.57	-	-	1.00	1.00	0.57	-	-	1.00	1.00	0.63	-	-	1.00	1.00	0.63	-	-	
	ΔT	18.07	16.30	13.00	-	-	18.28	16.50	13.20	-	-	18.01	16.24	12.93	-	-	17.77	16.00	12.70	-	-	17.77	16.00	12.70	-	-	18.88	17.11	13.80	-	-	18.88	17.11	13.80	-	-	
	kW	1545	1544	1541	-	-	1919	1918	1915	-	-	2133	2132	2129	-	-	2372	2370	2367	-	-	2372	2370	2367	-	-	2652	2650	2647	-	-	2652	2650	2647	-	-	
	Amps	5.50	5.49	5.48	-	-	7.13	7.12	7.11	-	-	8.06	8.05	8.04	-	-	9.09	9.09	9.07	-	-	9.09	9.09	9.07	-	-	10.31	10.31	10.29	-	-	10.31	10.31	10.29	-	-	
	Hi PR	238	239	241	-	-	315	316	317	-	-	357	358	360	-	-	402	403	405	-	-	402	403	405	-	-	451	452	453	-	-	451	452	453	-	-	
Lo PR	137	139	142	-	-	145	147	150	-	-	159	160	164	-	-	165	166	170	-	-	165	166	170	-	-	172	174	177	-	-	172	174	177	-	-		
1000	MBh	27.1	27.5	28.3	-	-	26.2	26.6	27.4	-	-	25.0	25.4	26.2	-	-	23.6	24.0	24.8	-	-	23.6	24.0	24.8	-	-	22.3	22.7	23.5	-	-	22.3	22.7	23.5	-	-	
	S/T	0.77	0.69	0.54	-	-	1.00	0.69	0.55	-	-	1.00	0.72	0.57	-	-	1.00	1.00	0.62	-	-	1.00	1.00	0.62	-	-	1.00	1.00	0.68	-	-	1.00	1.00	0.68	-	-	
	ΔT	16.61	14.84	11.53	-	-	16.56	14.79	11.49	-	-	16.54	14.77	11.47	-	-	16.31	14.54	11.23	-	-	16.31	14.54	11.23	-	-	17.42	15.64	12.34	-	-	17.42	15.64	12.34	-	-	
	kW	1558	1556	1553	-	-	1932	1931	1928	-	-	2146	2144	2141	-	-	2384	2383	2380	-	-	2384	2383	2380	-	-	2664	2663	2660	-	-	2664	2663	2660	-	-	
	Amps	5.55	5.55	5.53	-	-	7.18	7.18	7.16	-	-	8.11	8.10	8.09	-	-	9.15	9.14	9.13	-	-	9.15	9.14	9.13	-	-	10.37	10.36	10.35	-	-	10.37	10.36	10.35	-	-	
	Hi PR	242	243	244	-	-	318	319	321	-	-	360	361	363	-	-	406	407	408	-	-	406	407	408	-	-	454	455	457	-	-	454	455	457	-	-	
Lo PR	141	143	146	-	-	149	151	154	-	-	162	164	168	-	-	168	170	174	-	-	168	170	174	-	-	176	178	181	-	-	176	178	181	-	-		

700	MBh	26.0	26.4	27.1	28.3	25.8	26.1	26.9	28.1	25.1	25.4	26.2	27.4	23.9	24.3	25.1	26.2	22.9	22.8	23.6	24.8	21.2	21.5	22.3	23.5
	S/T	1.00	0.70	0.55	0.4	1.00	0.70	0.56	0.4	1.00	0.73	0.58	0.4	1.00	1.00	0.60	0.4	22.99	21.22	17.92	14.5	24.10	22.33	19.02	15.6
	ΔT	23.29	21.52	18.22	14.8	23.25	21.48	18.17	14.7	23.50	21.72	18.42	15.0	23.23	21.46	18.15	14.7	22.99	21.22	17.92	14.5	24.10	22.33	19.02	15.6
	kW	1533	1531	1528	1542	1709	1708	1705	1719	1907	1906	1902	1916	2121	2119	2116	2130	2359	2358	2355	2368	2639	2638	2635	2648
	Amps	5.45	5.44	5.43	5.5	6.21	6.21	6.19	6.3	7.07	7.07	7.05	7.1	8.00	8.00	7.98	8.0	9.04	9.03	9.02	9.1	10.26	10.25	10.24	10.3
	Hi PR	236	237	239	242.9	273	274	276	280.2	313	314	315	319.3	355	356	357	361.4	400	401	403	406.8	448	449	451	455.2
Lo PR	135	136	140	145.6	143	145	148	153.8	150	152	155	161.0	156	158	161	167.1	162	164	167	173.0	170	171	175	180.5	
825	MBh	26.4	26.8	27.5	28.7	26.2	26.5	27.3	28.5	25.5	25.9	26.6	27.8	24.3	24.7	25.5	26.6	22.9	23.3	24.0	25.2	21.6	21.9	22.7	23.9
	S/T	1.00	0.78	0.63	0.5	1.00	0.79	0.64	0.5	1.00	0.81	0.67	0.5	1.00	1.00	0.69	0.5	21.66	19.89	16.59	13.2	22.77	21.00	17.70	14.3
	ΔT	21.97	20.20	16.89	13.5	21.92	20.15	16.84	13.4	22.17	20.40	17.09	13.7	21.90	20.13	16.82	13.4	21.66	19.89	16.59	13.2	22.77	21.00	17.70	14.3
	kW	1544	1543	1540	1553	1721	1719	1716	1730	1918	1917	1914	1927	2132	2131	2128	2141	2371	2369	2366	2380	2651	2649	2646	2660
	Amps	5.49	5.49	5.48	5.5	6.26	6.26	6.24	6.3	7.12	7.12	7.10	7.2	8.05	8.04	8.03	8.1	9.09	9.08	9.07	9.1	10.31	10.30	10.29	10.3
	Hi PR	239	240	241	245.4	276	277	279	282.7	315	316	318	321.8	357	358	360	363.9	402	403	405	409.2	451	452	454	457.6
Lo PR	137	139	142	147.9	145	147	150	156.2	153	154	158	163.4	159	160	164	169.4	165	166	170	175.4	172	174	177	182.9	
1000	MBh	27.1	27.5	28.3	29.5	26.9	27.3	28.1	29.2	26.2	26.6	27.4	28.6	25.1	25.4	26.2	27.4	23.6	24.0	24.8	26.0	22.3	22.7	23.5	24.7
	S/T	1.00	0.83	0.68	0.5	1.00	0.83	0.69	0.5	1.00	0.86	0.71	0.6	1.00	1.00	0.74	0.6	20.20	18.43	15.12	11.7	21.31	19.54	16.23	12.8
	ΔT	20.50	18.73	15.43	12.0	20.45	18.68	15.38	12.0	20.70	18.93	15.63	12.2	20.44	18.67	15.36	11.9	20.20	18.43	15.12	11.7	21.31	19.54	16.23	12.8
	kW	1557	1555	1552	1566	1733	1732	1729	1742	1931	1929	1926	1940	2144	2143	2140	2154	2383	2382	2379	2392	2663	2662	2659	2672
	Amps	5.55	5.54	5.53	5.6	6.32	6.31	6.30	6.4	7.18	7.17	7.16	7.2	8.11	8.10	8.09	8.1	9.14	9.14	9.12	9.2	10.36	10.35	10.34	10.4
	Hi PR	242	243	245	248.7	279	280	282	286.0	318	319	321	325.1	360	361	363	367.2	406	407	408	412.6	454	455	457	461.0
Lo PR	141	143	146	151.9	149	151	154	160.1	156	158	162	167.3	162	164	168	173.4	168	170	174	179.3	176	178	181	186.8	

IDB: Entering Indoor Dry Bulb Temperature
 High and low pressures are measured at the liquid and suction service valves.
 Shaded area reflects ACCA (TVA) conditions
 kW = Total system power
 Amps = outdoor unit amps (comp.+fan)

EXPANDED COOLING DATA — GPGM536***31 LOW STAGE1 (CONT.)

IDB	AIRFLOW	OUTDOOR AMBIENT TEMPERATURE												ENTERING INDOOR WET BULB TEMPERATURE											
		65°F				75°F				85°F				95°F				105°F				115°F			
		59	63	67	71	59	63	67	71	59	63	67	71	59	63	67	71	59	63	67	71	59	63	67	71
700	MBh	26.1	26.5	27.3	28.5	25.9	26.3	27.0	28.2	25.2	25.6	26.4	27.5	24.0	24.4	25.2	26.4	22.6	23.0	23.8	24.9	21.3	21.7	22.5	23.6
	S/T	1.00	0.83	0.69	0.5	1.00	0.84	0.69	0.5	1.00	1.00	0.72	0.6	1.00	1.00	0.74	0.6	1.00	1.00	1.00	0.6	1.00	1.00	1.00	0.7
	ΔT	27.21	25.44	22.14	18.7	27.17	25.40	22.09	18.7	27.41	25.64	22.34	18.9	27.15	25.38	22.07	18.6	26.91	25.14	21.83	18.4	28.02	26.25	22.94	19.5
	kW	1534	1532	1529	1543	1710	1709	1706	1720	1908	1906	1903	1917	2121	2120	2117	2131	2360	2359	2356	2369	2640	2639	2636	2649
	Amps	5.45	5.44	5.43	5.5	6.22	6.21	6.20	6.3	7.08	7.07	7.06	7.1	8.01	8.00	7.99	8.0	9.04	9.04	9.02	9.1	10.26	10.25	10.24	10.3
80	Hi PR	237	238	239	243.4	274	275	277	280.7	313	314	316	319.8	355	356	358	361.8	400	401	403	407.2	449	450	451	455.6
	Lo PR	135	137	140	146.2	144	145	149	154.4	151	152	156	161.6	157	158	162	167.7	163	164	168	173.6	170	172	175	181.1
	MBh	26.5	26.9	27.7	28.9	26.3	26.7	27.4	28.6	25.6	26.0	26.8	28.0	24.5	24.8	25.6	26.8	23.0	23.4	24.2	25.4	21.7	22.1	22.9	24.0
	S/T	1.00	0.92	0.77	0.6	1.00	1.00	0.78	0.6	1.00	1.00	0.80	0.6	1.00	1.00	0.82	0.7	1.00	1.00	1.00	0.7	1.00	1.00	1.00	0.7
	ΔT	25.89	24.12	20.81	17.4	25.84	24.07	20.76	17.3	26.09	24.32	21.01	17.6	25.82	24.05	20.74	17.3	25.58	23.81	20.51	17.1	26.69	24.92	21.62	18.2
1000	kW	1545	1544	1541	1554	1722	1720	1717	1731	1919	1918	1915	1928	2133	2131	2128	2142	2372	2370	2367	2381	2652	2650	2647	2661
	Amps	5.50	5.49	5.48	5.5	6.27	6.26	6.25	6.3	7.13	7.12	7.11	7.2	8.05	8.05	8.04	8.1	9.09	9.09	9.07	9.1	10.31	10.30	10.29	10.4
	Hi PR	239	240	242	245.8	276	277	279	283.1	315	316	318	322.2	357	359	360	364.3	403	404	406	409.7	451	452	454	458.1
	Lo PR	138	139	143	148.5	146	148	151	156.8	153	155	158	164.0	159	161	164	170.0	165	167	170	176.0	173	174	178	183.5
	MBh	27.3	27.6	28.4	29.6	27.0	27.4	28.2	29.4	26.4	26.7	27.5	28.7	25.2	25.6	26.3	27.5	23.8	24.1	24.9	26.1	22.5	22.8	23.6	24.8
85	S/T	1.00	0.96	0.82	0.7	1.00	1.00	0.82	0.7	1.00	1.00	0.85	0.7	1.00	1.00	1.00	0.7	1.00	1.00	1.00	0.7	1.00	1.00	1.00	0.8
	ΔT	24.42	22.65	19.35	15.9	24.37	22.60	19.30	15.9	24.62	22.85	19.55	16.1	24.36	22.58	19.28	15.9	24.12	22.35	19.04	15.6	25.23	23.46	20.15	16.7
	kW	1557	1556	1553	1567	1734	1733	1730	1743	1932	1930	1927	1941	2145	2144	2141	2154	2384	2383	2380	2393	2664	2663	2660	2673
	Amps	5.55	5.55	5.53	5.6	6.32	6.32	6.30	6.4	7.18	7.17	7.16	7.2	8.11	8.10	8.09	8.1	9.15	9.14	9.13	9.2	10.36	10.36	10.35	10.4
	Hi PR	242	243	245	249.2	280	281	282	286.5	319	320	321	325.5	361	362	364	367.6	406	407	409	413.0	455	456	457	461.4
700	Lo PR	142	143	147	152.5	150	151	155	160.7	157	159	162	167.9	163	165	168	174.0	169	171	174	179.9	177	178	182	187.4
	MBh	26.6	26.9	27.7	28.9	26.3	26.7	27.5	28.7	25.7	26.0	26.8	28.0	24.5	24.8	25.6	26.8	23.1	23.4	24.2	25.4	21.7	22.1	22.9	24.1
	S/T	1.00	1.00	0.80	0.6	1.00	1.00	0.80	0.6	1.00	1.00	0.83	0.7	1.00	1.00	1.00	0.7	1.00	1.00	1.00	0.7	1.00	1.00	1.00	1.0
	ΔT	30.69	28.92	25.61	22.2	30.64	28.87	25.57	22.1	30.89	29.12	25.81	22.4	30.62	28.85	25.55	22.1	30.39	28.62	25.31	21.9	31.50	29.72	26.42	23.0
	kW	1537	1536	1533	1546	1714	1712	1709	1723	1911	1910	1907	1920	2125	2123	2120	2134	2364	2362	2359	2373	2644	2642	2639	2653
825	Amps	5.46	5.46	5.44	5.5	6.23	6.23	6.21	6.3	7.09	7.09	7.07	7.1	8.02	8.01	8.00	8.1	9.06	9.05	9.04	9.1	10.28	10.27	10.26	10.3
	Hi PR	238	239	240	244.5	275	276	278	281.8	314	315	317	320.9	356	357	359	362.9	402	403	404	408.3	450	451	453	456.7
	Lo PR	137	139	142	148.2	146	147	151	156.4	153	154	158	163.6	159	160	164	169.7	165	166	170	175.6	172	174	177	183.1
	MBh	27.0	27.3	28.1	29.3	26.7	27.1	27.9	29.1	26.1	26.4	27.2	28.4	24.9	25.3	26.0	27.2	23.5	23.8	24.6	25.8	22.2	22.5	23.3	24.5
	S/T	1.00	1.00	0.88	0.7	1.00	1.00	0.89	0.7	1.00	1.00	1.00	0.8	1.00	1.00	1.00	0.8	1.00	1.00	1.00	0.8	1.00	1.00	1.00	1.0
1000	ΔT	29.36	27.59	24.29	20.9	29.31	27.54	24.24	20.8	29.56	27.79	24.49	21.1	29.30	27.53	24.22	20.8	29.06	27.29	23.98	20.6	30.17	28.40	25.09	21.7
	kW	1548	1547	1544	1557	1725	1724	1721	1734	1923	1921	1918	1932	2136	2135	2132	2145	2375	2374	2371	2384	2655	2654	2651	2664
	Amps	5.51	5.51	5.49	5.6	6.28	6.28	6.26	6.3	7.14	7.13	7.12	7.2	8.07	8.06	8.05	8.1	9.11	9.10	9.09	9.1	10.33	10.32	10.31	10.4
	Hi PR	240	241	243	247.0	277	278	280	284.3	317	318	319	323.3	359	360	361	365.4	404	405	407	410.8	452	453	455	459.2
	Lo PR	140	141	145	150.6	148	150	153	158.8	155	157	160	166.0	161	163	166	172.1	167	169	172	178.0	175	176	180	185.5
85	MBh	27.7	28.1	28.9	30.1	27.5	27.9	28.6	29.8	26.8	27.2	28.0	29.1	25.6	26.0	26.8	28.0	24.2	24.6	25.4	26.5	22.9	23.3	24.0	25.2
	S/T	1.00	1.00	0.93	0.8	1.00	1.00	0.93	0.8	1.00	1.00	1.00	0.8	1.00	1.00	1.00	0.8	1.00	1.00	1.00	0.8	1.00	1.00	1.00	1.0
	ΔT	27.90	26.13	22.82	19.4	27.85	26.08	22.77	19.3	28.10	26.33	23.02	19.6	27.83	26.06	22.75	19.3	27.59	25.82	22.52	19.1	28.70	26.93	23.63	20.2
	kW	1561	1559	1556	1570	1738	1736	1733	1747	1935	1934	1931	1944	2149	2147	2144	2158	2387	2386	2383	2397	2667	2666	2663	2677
	Amps	5.57	5.56	5.55	5.6	6.34	6.33	6.32	6.4	7.20	7.19	7.18	7.2	8.12	8.12	8.10	8.2	9.16	9.16	9.14	9.2	10.38	10.37	10.36	10.4
85	Hi PR	243	244	246	250.3	281	282	283	287.6	320	321	323	326.7	362	363	365	368.7	407	408	410	414.1	456	457	458	462.5
	Lo PR	144	145	149	154.5	152	154	157	162.7	159	161	164	169.9	165	167	170	176.0	171	173	176	181.9	179	180	184	189.4

IDB: Entering Indoor Dry Bulb Temperature
 High and low pressures are measured at the liquid and suction service valves.
 Shaded area reflects AHRI (TVA) conditions
 kW = Total system power
 Amps = outdoor unit amps (comp.+fan)

EXPANDED COOLING DATA — GPGM536***31 HIGH STAGE

IDB		OUTDOOR AMBIENT TEMPERATURE																																																
		65°F						75°F						85°F						95°F						105°F						115°F																		
		59	63	67	71	75	79	59	63	67	71	75	79	59	63	67	71	75	79	59	63	67	71	75	79	59	63	67	71	75	79	59	63	67	71	75	79													
AIRFLOW		ENTERING INDOOR WET BULB TEMPERATURE																																																
1000		MBh	36.1	36.6	37.7	-	35.8	36.3	37.3	-	34.8	35.3	36.4	-	33.2	33.7	34.8	-	31.2	31.7	32.8	-	29.4	29.9	31.0	-	36.1	36.6	37.7	-	35.8	36.3	37.3	-	34.8	35.3	36.4	-	33.2	33.7	34.8	-	31.2	31.7	32.8	-	29.4	29.9	31.0	-
		S/T	0.61	0.53	0.39	-	0.62	0.54	0.39	-	1.00	0.56	0.42	-	1.00	0.58	0.44	-	1.00	0.61	0.47	-	1.00	1.00	0.52	-	0.61	0.53	0.39	-	0.62	0.54	0.39	-	1.00	0.56	0.42	-	1.00	0.58	0.44	-	1.00	0.61	0.47	-	1.00	1.00	0.52	-
		ΔT	20.26	18.43	15.00	-	20.21	18.38	14.95	-	20.47	18.64	15.21	-	20.20	18.36	14.94	-	19.95	18.12	14.69	-	21.10	19.26	15.84	-	20.26	18.43	15.00	-	20.21	18.38	14.95	-	20.47	18.64	15.21	-	20.20	18.36	14.94	-	19.95	18.12	14.69	-	21.10	19.26	15.84	-
		kW	2436	2434	2429	-	2718	2715	2710	-	3031	3029	3024	-	3371	3369	3364	-	3751	3748	3744	-	4196	4194	4189	-	2436	2434	2429	-	2718	2715	2710	-	3031	3029	3024	-	3371	3369	3364	-	3751	3748	3744	-	4196	4194	4189	-
		Amps	8.66	8.65	8.63	-	9.88	9.87	9.85	-	11.24	11.23	11.21	-	12.72	12.71	12.69	-	14.37	14.36	14.34	-	16.31	16.30	16.27	-	8.66	8.65	8.63	-	9.88	9.87	9.85	-	11.24	11.23	11.21	-	12.72	12.71	12.69	-	14.37	14.36	14.34	-	16.31	16.30	16.27	-
Hi PR	247	248	249	-	286	287	288	-	326	327	329	-	370	371	373	-	418	419	421	-	469	470	471	-	247	248	249	-	286	287	288	-	326	327	329	-	370	371	373	-	418	419	421	-	469	470	471	-		
Lo PR	131	132	136	-	139	140	144	-	146	147	151	-	152	153	157	-	157	159	162	-	165	166	170	-	131	132	136	-	139	140	144	-	146	147	151	-	152	153	157	-	157	159	162	-	165	166	170	-		
70		MBh	36.7	37.2	38.3	-	36.4	36.9	38.0	-	35.4	35.9	37.0	-	33.8	34.3	35.4	-	31.8	32.3	33.4	-	30.0	30.5	31.6	-	36.7	37.2	38.3	-	36.4	36.9	38.0	-	35.4	35.9	37.0	-	33.8	34.3	35.4	-	31.8	32.3	33.4	-	30.0	30.5	31.6	-
		S/T	0.70	0.62	0.48	-	0.71	0.63	0.49	-	1.00	0.66	0.51	-	1.00	0.68	0.53	-	1.00	0.70	0.56	-	1.00	1.00	0.61	-	0.70	0.62	0.48	-	0.71	0.63	0.49	-	1.00	0.66	0.51	-	1.00	0.68	0.53	-	1.00	0.70	0.56	-	1.00	1.00	0.61	-
		ΔT	18.73	16.90	13.47	-	18.68	16.85	13.42	-	18.94	17.10	13.68	-	18.66	16.83	13.40	-	18.42	16.58	13.16	-	19.56	17.73	14.30	-	18.73	16.90	13.47	-	18.68	16.85	13.42	-	18.94	17.10	13.68	-	18.66	16.83	13.40	-	18.42	16.58	13.16	-	19.56	17.73	14.30	-
		kW	2457	2454	2450	-	2738	2735	2731	-	3052	3049	3045	-	3391	3389	3384	-	3771	3769	3764	-	4216	4214	4209	-	2457	2454	2450	-	2738	2735	2731	-	3052	3049	3045	-	3391	3389	3384	-	3771	3769	3764	-	4216	4214	4209	-
		Amps	8.74	8.73	8.71	-	9.97	9.96	9.94	-	11.33	11.32	11.30	-	12.81	12.80	12.78	-	14.46	14.45	14.43	-	16.39	16.38	16.36	-	8.74	8.73	8.71	-	9.97	9.96	9.94	-	11.33	11.32	11.30	-	12.81	12.80	12.78	-	14.46	14.45	14.43	-	16.39	16.38	16.36	-
Hi PR	249	250	252	-	288	289	291	-	329	330	332	-	373	374	376	-	421	422	424	-	471	472	474	-	249	250	252	-	288	289	291	-	329	330	332	-	373	374	376	-	421	422	424	-	471	472	474	-		
Lo PR	133	135	138	-	141	143	146	-	148	150	153	-	154	156	159	-	160	162	165	-	167	169	172	-	133	135	138	-	141	143	146	-	148	150	153	-	154	156	159	-	160	162	165	-	167	169	172	-		
1400		MBh	37.5	38.0	39.1	-	37.2	37.7	38.8	-	36.2	36.7	37.8	-	34.6	35.1	36.2	-	32.6	33.1	34.2	-	30.8	31.3	32.4	-	37.5	38.0	39.1	-	37.2	37.7	38.8	-	36.2	36.7	37.8	-	34.6	35.1	36.2	-	32.6	33.1	34.2	-	30.8	31.3	32.4	-
		S/T	0.75	0.67	0.52	-	1.00	0.67	0.53	-	1.00	0.70	0.56	-	1.00	0.72	0.58	-	1.00	1.00	0.60	-	1.00	1.00	0.65	-	0.75	0.67	0.52	-	1.00	0.67	0.53	-	1.00	0.70	0.56	-	1.00	0.72	0.58	-	1.00	1.00	0.60	-	1.00	1.00	0.65	-
		ΔT	17.51	15.68	12.25	-	17.46	15.63	12.20	-	17.72	15.89	12.46	-	17.44	15.61	12.18	-	17.20	15.36	11.94	-	18.35	16.51	13.09	-	17.51	15.68	12.25	-	17.46	15.63	12.20	-	17.72	15.89	12.46	-	17.44	15.61	12.18	-	17.20	15.36	11.94	-	18.35	16.51	13.09	-
		kW	2472	2470	2465	-	2754	2751	2747	-	3068	3065	3061	-	3407	3405	3400	-	3787	3784	3780	-	4232	4230	4225	-	2472	2470	2465	-	2754	2751	2747	-	3068	3065	3061	-	3407	3405	3400	-	3787	3784	3780	-	4232	4230	4225	-
		Amps	8.81	8.80	8.78	-	10.04	10.03	10.00	-	11.40	11.39	11.37	-	12.88	12.87	12.85	-	14.53	14.52	14.50	-	16.46	16.45	16.43	-	8.81	8.80	8.78	-	10.04	10.03	10.00	-	11.40	11.39	11.37	-	12.88	12.87	12.85	-	14.53	14.52	14.50	-	16.46	16.45	16.43	-
Hi PR	252	253	255	-	291	292	294	-	332	333	335	-	376	377	379	-	423	425	426	-	474	475	477	-	252	253	255	-	291	292	294	-	332	333	335	-	376	377	379	-	423	425	426	-	474	475	477	-		
Lo PR	136	138	141	-	144	146	149	-	151	153	156	-	157	159	162	-	163	165	168	-	170	172	175	-	136	138	141	-	144	146	149	-	151	153	156	-	157	159	162	-	163	165	168	-	170	172	175	-		

1000		MBh	36.1	36.6	37.7	39.3	35.8	36.3	37.4	39.0	34.8	35.3	36.4	38.1	33.2	33.7	34.8	36.4	31.2	31.7	32.8	34.5	29.4	29.9	31.0	32.6	36.1	36.6	37.7	39.3	35.8	36.3	37.4	39.0	34.8	35.3	36.4	38.1	33.2	33.7	34.8	36.4	31.2	31.7	32.8	34.5	29.4	29.9	31.0	32.6
		S/T	0.75	0.67	0.52	0.4	1.00	0.67	0.53	0.4	1.00	0.70	0.56	0.4	1.00	0.72	0.58	0.4	1.00	1.00	0.60	0.5	1.00	1.00	0.66	0.5	0.75	0.67	0.52	0.4	1.00	0.67	0.53	0.4	1.00	0.70	0.56	0.4	1.00	0.72	0.58	0.4	1.00	1.00	0.60	0.5	1.00	1.00	0.66	0.5
		ΔT	24.30	22.46	19.04	15.5	24.25	22.41	18.99	15.4	24.51	22.67	19.25	15.7	24.23	22.39	18.97	15.4	23.98	22.15	18.72	15.2	25.13	23.30	19.87	16.3	24.30	22.46	19.04	15.5	24.25	22.41	18.99	15.4	24.51	22.67	19.25	15.7	24.23	22.39	18.97	15.4	23.98	22.15	18.72	15.2	25.13	23.30	19.87	16.3
		kW	2435	2432	2427	2449	2716	2713	2709	2730	3030	3027	3023	3044	3369	3367	3362	3384	3749	3746	3742	3763	4194	4192	4187	4208	2435	2432	2427	2449	2716	2713	2709	2730	3030	3027	3023	3044	3369	3367	3362	3384	3749	3746	3742	3763	4194	4192	4187	4208
		Amps	8.65	8.64	8.62	8.7	9.87	9.86	9.84	9.9	11.23	11.23	11.20	11.3	12.71	12.70	12.68	12.8	14.36	14.35	14.33	14.4	16.30	16.29	16.27	16.4	8.65	8.64	8.62	8.7	9.87	9.86	9.84	9.9	11.23	11.23	11.20	11.3	12.71	12.70	12.68	12.8	14.36	14.35	14.33	14.4	16.30	16.29	16.27	16.4
Hi PR	247	248	250	253.9	286	287	289	292.9	327	328	329	333.7	371	372	373	377.8	418	419	421	425.2	469	470	472	475.9	247	248	250	253.9	286	287	289	292.9	327	328	329	333.7	371	372	373	377.8	418	419	421	425.2	469	470	472	475.9		
Lo PR	131	132	136	141.4	139	140	144	149.4	146	147	151	156.4	152	153	157	162.3	158	159	162	168.1	165	166	170	175.4	131	132	136	141.4	139	140	144	149.4	146	147	151	156.4	152	153	157	162.3	158	159	162	168.1	165	166	170	175.4		
75		MBh	36.7	37.2	38.3	40.0	36.4	36.9	38.0	39.6	35.4	36.0	37.0	38.7	33.8	34.3	35.4	37.1	31.8	32.3	33.4	35.1	30.0	30.5	31.6	3																								

EXPANDED COOLING DATA — GPGM536***31 HIGH STAGE (CONT.)

IDB		OUTDOOR AMBIENT TEMPERATURE																																															
		65°F						75°F						85°F						95°F						105°F						115°F																	
		59	63	67	71	75	79	59	63	67	71	75	79	59	63	67	71	75	79	59	63	67	71	75	79	59	63	67	71	75	79	59	63	67	71	75	79												
		ENTERING INDOOR WET BULB TEMPERATURE																																															
		AIRFLOW																																															
80	MBh	36.3	36.8	37.9	39.5	36.0	36.5	37.6	39.2	35.0	35.5	36.6	38.3	33.4	33.9	35.0	36.6	31.4	31.9	33.0	34.6	29.6	30.1	31.2	32.8	36.3	36.8	37.9	39.5	36.0	36.5	37.6	39.2	35.0	35.5	36.6	38.3	33.4	33.9	35.0	36.6	31.4	31.9	33.0	34.6	29.6	30.1	31.2	32.8
	S/T	1.00	0.80	0.66	0.5	1.00	0.81	0.66	0.5	1.00	1.00	0.69	0.5	1.00	1.00	0.71	0.6	1.00	1.00	0.83	0.7	1.00	1.00	0.7	0.6	1.00	0.80	0.66	0.5	1.00	1.00	0.69	0.5	1.00	1.00	0.71	0.6	1.00	1.00	0.83	0.7	1.00	1.00	0.7	0.6				
	ΔT	28.36	26.53	23.10	19.6	28.31	26.47	23.05	19.5	28.57	26.73	23.31	19.8	28.29	26.46	23.03	19.5	28.05	26.21	22.79	19.2	29.19	27.36	23.93	20.4	28.36	26.53	23.10	19.6	28.31	26.47	23.05	19.5	28.57	26.73	23.31	19.8	28.29	26.46	23.03	19.5	28.05	26.21	22.79	19.2	29.19	27.36	23.93	20.4
	kW	2436	2434	2429	2450	2717	2715	2710	2732	3031	3029	3024	3046	3371	3368	3364	3385	3750	3748	3743	3765	4195	4193	4188	4210	2436	2434	2429	2450	2717	2715	2710	2732	3031	3029	3024	3046	3371	3368	3364	3385	3750	3748	3743	3765	4195	4193	4188	4210
	Amps	8.65	8.64	8.62	8.7	9.88	9.87	9.85	9.9	11.24	11.23	11.21	11.3	12.72	12.71	12.69	12.8	14.37	14.36	14.34	14.4	16.30	16.29	16.27	16.4	8.65	8.64	8.62	8.7	9.88	9.87	9.85	9.9	11.24	11.23	11.21	11.3	12.72	12.71	12.69	12.8	14.37	14.36	14.34	14.4	16.30	16.29	16.27	16.4
Hi PR	247	248	250	254.3	286	287	289	293.3	327	328	330	334.2	371	372	374	378.2	419	420	421	425.7	469	470	472	476.3	247	248	250	254.3	286	287	289	293.3	327	328	330	334.2	371	372	374	378.2	419	420	421	425.7	469	470	472	476.3	
Lo PR	131	133	136	141.9	139	141	144	149.9	146	148	151	156.9	152	154	157	162.9	158	160	163	168.7	165	167	170	175.9	131	133	136	141.9	139	141	144	149.9	146	148	151	156.9	152	154	157	162.9	158	160	163	168.7	165	167	170	175.9	
1000	MBh	36.9	37.4	38.5	40.1	36.6	37.1	38.2	39.8	35.6	36.1	37.2	38.9	34.0	34.5	35.6	37.3	32.0	32.5	33.6	35.3	30.2	30.7	31.8	33.4	36.9	37.4	38.5	40.1	36.6	37.1	38.2	39.8	35.6	36.1	37.2	38.9	34.0	34.5	35.6	37.3	32.0	32.5	33.6	35.3	30.2	30.7	31.8	33.4
	S/T	1.00	0.89	0.75	0.6	1.00	0.90	0.76	0.6	1.00	1.00	0.78	0.6	1.00	1.00	0.80	0.7	1.00	1.00	0.83	0.7	1.00	1.00	0.7	0.6	1.00	0.89	0.75	0.6	1.00	0.90	0.76	0.6	1.00	1.00	0.78	0.6	1.00	1.00	0.80	0.7	1.00	1.00	0.83	0.7	1.00	1.00	0.7	0.6
	ΔT	26.83	24.99	21.57	18.0	26.78	24.94	21.51	18.0	27.03	25.20	21.77	18.2	26.76	24.92	21.50	17.9	26.51	24.68	21.25	17.7	27.66	25.83	22.40	18.9	26.83	24.99	21.57	18.0	26.78	24.94	21.51	18.0	27.03	25.20	21.77	18.2	26.76	24.92	21.50	17.9	26.51	24.68	21.25	17.7	27.66	25.83	22.40	18.9
	kW	2456	2454	2449	2471	2737	2735	2730	2752	3051	3049	3044	3066	3391	3389	3384	3405	3770	3768	3763	3785	4216	4213	4209	4230	2456	2454	2449	2471	2737	2735	2730	2752	3051	3049	3044	3066	3391	3389	3384	3405	3770	3768	3763	3785	4216	4213	4209	4230
	Amps	8.74	8.73	8.71	8.8	9.96	9.95	9.93	10.0	11.33	11.32	11.30	11.4	12.81	12.80	12.78	12.9	14.46	14.45	14.43	14.5	16.39	16.38	16.36	16.5	8.74	8.73	8.71	8.8	9.96	9.95	9.93	10.0	11.33	11.32	11.30	11.4	12.81	12.80	12.78	12.9	14.46	14.45	14.43	14.5	16.39	16.38	16.36	16.5
Hi PR	250	251	253	257.2	289	290	292	296.2	330	331	333	337.0	374	375	377	381.1	421	422	424	428.5	472	473	475	479.2	250	251	253	257.2	289	290	292	296.2	330	331	333	337.0	374	375	377	381.1	421	422	424	428.5	472	473	475	479.2	
Lo PR	134	136	139	144.5	142	144	147	152.5	149	151	154	159.5	155	156	160	165.4	161	162	166	171.2	168	170	173	178.5	134	136	139	144.5	142	144	147	152.5	149	151	154	159.5	155	156	160	165.4	161	162	166	171.2	168	170	173	178.5	
1400	MBh	37.7	38.2	39.3	40.9	37.4	37.9	39.0	40.6	36.4	36.9	38.0	39.7	34.8	35.3	36.4	38.0	32.8	33.3	34.4	36.1	31.0	31.5	32.6	34.2	37.7	38.2	39.3	40.9	37.4	37.9	39.0	40.6	36.4	36.9	38.0	39.7	34.8	35.3	36.4	38.0	32.8	33.3	34.4	36.1	31.0	31.5	32.6	34.2
	S/T	1.00	0.93	0.79	0.6	1.00	1.00	0.80	0.6	1.00	1.00	0.82	0.7	1.00	1.00	0.84	0.7	1.00	1.00	0.87	0.7	1.00	1.00	0.8	0.8	1.00	0.93	0.79	0.6	1.00	1.00	0.80	0.6	1.00	1.00	0.82	0.7	1.00	1.00	0.84	0.7	1.00	1.00	0.87	0.7	1.00	1.00	0.8	0.8
	ΔT	25.61	23.77	20.35	16.8	25.56	23.72	20.30	16.7	25.82	23.98	20.55	17.0	25.54	23.70	20.28	16.7	25.29	23.46	20.03	16.5	26.44	24.61	21.18	17.6	25.61	23.77	20.35	16.8	25.56	23.72	20.30	16.7	25.82	23.98	20.55	17.0	25.54	23.70	20.28	16.7	25.29	23.46	20.03	16.5	26.44	24.61	21.18	17.6
	kW	2472	2470	2465	2487	2753	2751	2746	2768	3067	3065	3060	3082	3407	3405	3400	3421	3786	3784	3779	3801	4232	4229	4225	4246	2472	2470	2465	2487	2753	2751	2746	2768	3067	3065	3060	3082	3407	3405	3400	3421	3786	3784	3779	3801	4232	4229	4225	4246
	Amps	8.81	8.80	8.78	8.9	10.03	10.02	10.00	10.1	11.40	11.39	11.37	11.5	12.88	12.87	12.84	12.9	14.53	14.52	14.49	14.6	16.46	16.45	16.43	16.5	8.81	8.80	8.78	8.9	10.03	10.02	10.00	10.1	11.40	11.39	11.37	11.5	12.88	12.87	12.84	12.9	14.53	14.52	14.49	14.6	16.46	16.45	16.43	16.5
Hi PR	253	254	256	259.9	292	293	295	298.9	333	334	335	339.8	377	378	379	383.8	424	425	427	431.2	475	476	478	481.9	253	254	256	259.9	292	293	295	298.9	333	334	335	339.8	377	378	379	383.8	424	425	427	431.2	475	476	478	481.9	
Lo PR	137	138	142	147.4	145	146	150	155.4	152	153	157	162.4	158	159	163	168.3	164	165	169	174.1	171	172	176	181.4	137	138	142	147.4	145	146	150	155.4	152	153	157	162.4	158	159	163	168.3	164	165	169	174.1	171	172	176	181.4	
85	MBh	36.9	37.4	38.5	40.1	36.6	37.1	38.2	39.8	35.6	36.1	37.2	38.9	34.0	34.5	35.6	37.3	32.0	32.5	33.6	35.3	30.2	30.7	31.8	33.4	36.9	37.4	38.5	40.1	36.6	37.1	38.2	39.8	35.6	36.1	37.2	38.9	34.0	34.5	35.6	37.3	32.0	32.5	33.6	35.3	30.2	30.7	31.8	33.4
	S/T	1.00	0.91	0.76	0.6	1.00	1.00	0.77	0.6	1.00	1.00	0.80	0.6	1.00	1.00	0.82	0.7	1.00	1.00	0.85	0.7	1.00	1.00	0.8	0.7	1.00	0.91	0.76	0.6	1.00	1.00	0.77	0.6	1.00	1.00	0.80	0.6	1.00	1.00	0.82	0.7	1.00	1.00	0.85	0.7	1.00	1.00	0.8	0.7
	ΔT	31.96	30.13	26.70	23.2	31.91	30.08	26.65	23.1	32.17	30.33	26.91	23.4	31.89	30.06	26.63	23.1	31.65	29.81	26.39	22.8	32.80	30.96	27.54	24.0	31.96	30.13	26.70	23.2	31.91	30.08	26.65	23.1	32.17	30.33	26.91	23.4	31.89	30.06	26.63	23.1	31.65	29.81	26.39	22.8	32.80	30.96	27.54	24.0
	kW	2441	2439	2434	2456	2723	2720	2716	2737	3036	3034	3029	3051	3376	3374	3369	3391	3756	3753	3749	3770	4201	4199	4194	4215	2441	2439	2434	2456	2723	2720	2716	2737	3036	3034	3029	3051	3376	3374	3369	3391	3756	3753	3749	3770	4201	4199	4194	4215
	Amps	8.68	8.67	8.65	8.7	9.90	9.89	9.87	10.0	11.26	11.26	11.23	11.3	12.74	12.73	12.71	12.8	14.39	14.38	14.36	14.5	16.33	16.32	16.30	16.4	8.68	8.67	8.65	8.7	9.90	9.89	9.87	10.0	11.26	11.26	11.23	11.3	12.74	12.73	12.71	12.8	14.39	14.38	14.36	14.5	16.33	16.32	16.30	16.4
Hi PR	248	249	251	255.5	287	288	290	294.5	328	329	331	335.4	372																																				

EXPANDED COOLING DATA — GPGM542***31 LOW STAGE

IDB	AIRFLOW	OUTDOOR AMBIENT TEMPERATURE												115°F												
		65°F			75°F			85°F			95°F				105°F											
		59	63	67	71	59	63	67	71	59	63	67	71		59	63	67	71	59	63	67	71				
70	800	MBh	30.1	30.6	31.5	-	29.9	30.3	31.2	-	29.1	29.5	30.4	-	27.7	28.1	29.1	-	26.1	26.5	27.4	-	24.5	25.0	25.9	-
		S/T	0.54	0.47	0.34	-	0.55	0.47	0.34	-	0.57	0.50	0.37	-	1.00	0.52	0.39	-	1.00	0.54	0.41	-	1.00	0.59	0.46	-
		ΔT	20.68	18.84	15.41	-	20.63	18.79	15.36	-	20.89	19.05	15.62	-	20.61	18.77	15.34	-	20.37	18.53	15.09	-	21.52	19.68	16.25	-
		kW	1752	1750	1747	-	1968	1966	1962	-	2208	2206	2203	-	2468	2467	2463	-	2759	2758	2754	-	3101	3099	3095	-
		Amps	6.43	6.42	6.41	-	7.37	7.36	7.35	-	8.41	8.41	8.39	-	9.55	9.54	9.52	-	10.81	10.80	10.79	-	12.30	12.29	12.27	-
		Hi PR	250	251	252	-	289	290	292	-	331	332	334	-	375	377	378	-	424	425	426	-	475	476	478	-
Lo PR	125	126	130	-	133	134	137	-	139	141	144	-	145	146	150	-	150	152	155	-	157	159	162	-		
70	1000	MBh	30.8	31.2	32.1	-	30.5	30.9	31.8	-	29.7	30.1	31.0	-	28.3	28.8	29.7	-	26.7	27.1	28.0	-	25.1	25.6	26.5	-
		S/T	0.65	0.58	0.44	-	0.66	0.58	0.45	-	0.68	0.61	0.48	-	1.00	0.63	0.49	-	1.00	0.65	0.52	-	1.00	0.70	0.57	-
		ΔT	18.78	16.94	13.50	-	18.73	16.89	13.45	-	18.98	17.14	13.71	-	18.71	16.87	13.43	-	18.46	16.62	13.19	-	19.61	17.77	14.34	-
		kW	1771	1769	1766	-	1987	1985	1981	-	2227	2226	2222	-	2488	2486	2482	-	2779	2777	2773	-	3120	3118	3115	-
		Amps	6.52	6.51	6.49	-	7.45	7.44	7.43	-	8.50	8.49	8.48	-	9.63	9.62	9.61	-	10.90	10.89	10.87	-	12.38	12.37	12.36	-
		Hi PR	253	254	256	-	293	294	296	-	334	335	337	-	379	380	382	-	427	428	430	-	479	480	481	-
Lo PR	128	129	133	-	135	137	140	-	142	144	147	-	148	149	153	-	153	155	158	-	160	162	165	-		
70	1200	MBh	31.6	32.0	32.9	-	31.3	31.7	32.6	-	30.5	30.9	31.8	-	29.1	29.6	30.5	-	27.5	27.9	28.8	-	26.0	26.4	27.3	-
		S/T	0.69	0.62	0.49	-	0.70	0.63	0.49	-	1.00	0.65	0.52	-	1.00	0.67	0.54	-	1.00	0.69	0.56	-	1.00	1.00	0.61	-
		ΔT	17.33	15.49	12.06	-	17.28	15.44	12.01	-	17.54	15.70	12.27	-	17.26	15.42	11.99	-	17.02	15.18	11.75	-	18.17	16.33	12.90	-
		kW	1786	1784	1780	-	2001	1999	1996	-	2242	2240	2236	-	2502	2500	2497	-	2793	2791	2788	-	3134	3133	3129	-
		Amps	6.58	6.57	6.55	-	7.52	7.51	7.49	-	8.56	8.55	8.54	-	9.69	9.69	9.67	-	10.96	10.95	10.93	-	12.44	12.43	12.42	-
		Hi PR	256	258	259	-	296	297	299	-	338	339	340	-	382	383	385	-	430	432	433	-	482	483	485	-
Lo PR	131	133	136	-	139	140	144	-	146	147	150	-	151	153	156	-	157	158	162	-	164	165	169	-		

75	800	MBh	30.2	30.6	31.5	32.9	29.9	30.3	31.2	32.6	29.1	29.5	30.4	31.8	27.7	28.2	29.1	30.5	26.1	26.5	27.4	28.8	24.5	25.0	25.9	27.3
		S/T	0.67	0.60	0.46	0.3	0.68	0.60	0.47	0.3	0.69	0.63	0.49	0.4	1.00	0.64	0.51	0.4	1.00	0.67	0.53	0.4	1.00	1.00	0.58	0.4
		ΔT	24.73	22.89	19.45	15.9	24.68	22.84	19.40	15.8	24.93	23.09	19.66	16.1	24.66	22.82	19.38	15.8	24.41	22.57	19.14	15.6	25.56	23.72	20.29	16.7
		kW	1751	1749	1745	1762	1966	1964	1961	1977	2207	2205	2201	2218	2467	2465	2462	2478	2758	2756	2753	2769	3099	3098	3094	3110
		Amps	6.43	6.42	6.40	6.5	7.36	7.36	7.34	7.4	8.41	8.40	8.39	8.5	9.54	9.53	9.52	9.6	10.81	10.80	10.78	10.9	12.29	12.28	12.27	12.3
		Hi PR	250	251	253	257.1	289	291	292	296.7	331	332	334	338.2	376	377	379	382.9	424	425	427	431.1	475	476	478	482.5
Lo PR	125	126	130	135.0	133	134	137	142.7	139	141	144	149.4	145	147	150	155.1	151	152	155	160.6	157	159	162	167.6		
75	1000	MBh	30.8	31.2	32.1	33.5	30.5	30.9	31.8	33.2	29.7	30.1	31.0	32.4	28.3	28.8	29.7	31.1	26.7	27.1	28.0	29.4	25.2	25.6	26.5	27.9
		S/T	0.78	0.70	0.57	0.4	1.00	0.71	0.58	0.4	1.00	0.73	0.60	0.5	1.00	0.75	0.62	0.5	1.00	0.77	0.64	0.5	1.00	1.00	0.69	0.6
		ΔT	22.82	20.98	17.55	14.0	22.77	20.93	17.50	13.9	23.03	21.19	17.75	14.2	22.75	20.91	17.48	13.9	22.50	20.67	17.23	13.7	23.66	21.82	18.38	14.8
		kW	1770	1768	1764	1781	1985	1984	1980	1996	2226	2224	2221	2237	2486	2485	2481	2497	2777	2776	2772	2788	3119	3117	3113	3130
		Amps	6.51	6.50	6.49	6.6	7.45	7.44	7.42	7.5	8.49	8.48	8.47	8.5	9.62	9.62	9.60	9.7	10.89	10.88	10.87	10.9	12.37	12.37	12.35	12.4
		Hi PR	253	254	256	260.6	293	294	296	300.2	334	336	337	341.7	379	380	382	386.4	427	428	430	434.6	479	480	482	486.0
Lo PR	128	129	133	137.9	135	137	140	145.6	142	144	147	152.3	148	149	153	158.0	153	155	158	163.6	160	162	165	170.5		
75	1200	MBh	31.6	32.0	32.9	34.3	31.3	31.7	32.6	34.0	30.5	30.9	31.9	33.2	29.2	29.6	30.5	31.9	27.5	27.9	28.8	30.2	26.0	26.4	27.3	28.7
		S/T	0.82	0.75	0.61	0.5	1.00	0.75	0.62	0.5	1.00	0.78	0.64	0.5	1.00	0.80	0.66	0.5	1.00	0.82	0.68	0.5	1.00	1.00	0.74	0.6
		ΔT	21.38	19.54	16.10	12.5	21.33	19.49	16.05	12.5	21.59	19.75	16.31	12.8	21.31	19.47	16.03	12.5	21.06	19.22	15.79	12.2	22.21	20.37	16.94	13.4
		kW	1784	1782	1779	1795	2000	1998	1994	2011	2240	2239	2235	2251	2501	2499	2495	2512	2792	2790	2786	2803	3133	3131	3128	3144
		Amps	6.57	6.56	6.55	6.6	7.51	7.50	7.49	7.6	8.56	8.55	8.53	8.6	9.69	9.68	9.66	9.7	10.95	10.94	10.93	11.0	12.44	12.43	12.41	12.5
		Hi PR	257	258	260	263.9	296	297	299	303.5	338	339	341	345.0	382	384	385	389.7	431	432	434	437.9	482	483	485	489.3
Lo PR	131	133	136	141.4	139	140	144	149.0	146	147	150	155.7	151	153	156	161.4	157	158	162	167.0	164	165	169	173.9		

IDB: Entering Indoor Dry Bulb Temperature
 High and low pressures are measured at the liquid and suction service valves.
 Shaded area reflects ACCA (TVA) conditions
 kW = Total system power
 Amps = outdoor unit amps (comp. fan)

EXPANDED COOLING DATA — GPGM542***31 HIGH STAGE

IDB	AIRFLOW	OUTDOOR AMBIENT TEMPERATURE																			
		65°F			75°F			85°F			95°F			105°F			115°F				
		59	63	67	71	59	63	67	71	59	63	67	71	59	63	67	71	59	63	67	71
70	MBh	41.9	42.5	43.8	-	41.6	42.1	43.4	-	40.5	41.0	42.3	-	38.6	39.2	40.4	-	36.2	36.8	38.1	-
	S/T	0.53	0.46	0.33	-	0.54	0.46	0.33	-	0.56	0.49	0.36	-	0.58	0.50	0.38	-	1.00	0.53	0.40	-
	ΔT	21.43	19.53	15.97	-	21.38	19.47	15.92	-	21.65	19.74	16.18	-	21.36	19.45	15.90	-	21.11	19.20	15.64	-
	kW	2,785	2,783	2,777	-	3,128	3,125	3,119	-	3,511	3,508	3,502	-	3,924	3,922	3,916	-	4,387	4,384	4,378	-
	Amps	10.23	10.21	10.19	-	11.72	11.70	11.68	-	13.38	13.37	13.34	-	15.18	15.17	15.14	-	17.19	17.18	17.15	-
	Hi PR	261	262	264	-	303	304	306	-	346	347	349	-	393	394	396	-	443	444	446	-
Lo PR	121	123	126	-	129	130	134	-	135	137	140	-	141	142	146	-	146	148	151	-	
70	MBh	42.8	43.4	44.6	-	42.4	43.0	44.3	-	41.3	41.9	43.2	-	39.4	40.0	41.3	-	37.1	37.7	38.9	-
	S/T	0.64	0.56	0.43	-	0.64	0.57	0.44	-	0.66	0.59	0.46	-	1.00	0.61	0.48	-	1.00	0.63	0.50	-
	ΔT	19.46	17.55	13.99	-	19.40	17.50	13.94	-	19.67	17.77	14.21	-	19.38	17.48	13.92	-	19.13	17.22	13.67	-
	kW	2,816	2,813	2,807	-	3,159	3,156	3,150	-	3,541	3,538	3,532	-	3,955	3,952	3,946	-	4,418	4,415	4,409	-
	Amps	10.36	10.35	10.32	-	11.85	11.84	11.81	-	13.51	13.50	13.47	-	15.31	15.30	15.27	-	17.32	17.31	17.28	-
	Hi PR	265	266	268	-	306	307	309	-	350	351	353	-	396	398	399	-	447	448	450	-
Lo PR	124	126	129	-	132	133	136	-	138	140	143	-	144	145	148	-	149	151	154	-	
1500	MBh	43.9	44.5	45.8	-	43.5	44.1	45.4	-	42.4	43.0	44.3	-	40.5	41.1	42.4	-	38.2	38.8	40.1	-
	S/T	0.68	0.60	0.47	-	0.68	0.61	0.48	-	0.71	0.63	0.50	-	1.00	0.65	0.52	-	1.00	0.67	0.54	-
	ΔT	17.96	16.06	12.50	-	17.91	16.00	12.45	-	18.18	16.27	12.71	-	17.89	15.98	12.43	-	17.64	15.73	12.17	-
	kW	2,839	2,836	2,830	-	3,181	3,179	3,173	-	3,564	3,561	3,555	-	3,978	3,975	3,969	-	4,440	4,438	4,432	-
	Amps	10.46	10.45	10.42	-	11.95	11.94	11.91	-	13.61	13.60	13.57	-	15.41	15.40	15.37	-	17.42	17.41	17.38	-
	Hi PR	268	269	271	-	310	311	313	-	353	354	356	-	400	401	403	-	450	451	453	-
Lo PR	128	129	132	-	135	137	140	-	142	143	146	-	147	149	152	-	153	154	157	-	

1000	MBh	42.0	42.6	43.8	45.7	41.6	42.2	43.4	45.4	40.5	41.1	42.3	44.3	38.6	39.2	40.4	42.4	36.3	36.9	38.1	40.0
	S/T	0.65	0.58	0.45	0.3	0.66	0.59	0.46	0.3	1.00	0.61	0.48	0.3	1.00	0.63	0.50	0.4	2.50	2.30	2.39	19.83
	ΔT	25.62	23.72	20.16	16.5	25.57	23.66	20.11	16.4	25.84	23.93	20.37	16.7	25.55	23.64	20.09	16.4	25.30	23.41	17.86	14.2
	kW	2,783	2,780	2,775	2,801	3,126	3,123	3,117	3,143	3,508	3,506	3,500	3,526	3,922	3,920	3,914	3,940	4,385	4,382	4,376	4,402
	Amps	10.22	10.20	10.18	10.3	11.71	11.69	11.67	11.8	13.37	13.36	13.33	13.4	15.17	15.16	15.13	15.2	17.18	17.17	17.14	17.3
	Hi PR	261	262	264	268.9	303	304	306	310.4	346	347	349	353.8	393	394	396	400.5	443	444	446	450.9
Lo PR	121	123	126	131.3	129	130	134	138.8	135	137	140	145.3	141	143	146	150.8	146	148	151	156.3	
75	MBh	42.8	43.4	44.7	46.6	42.4	43.0	44.3	46.2	41.3	41.9	43.2	45.1	39.4	40.0	41.3	43.2	37.1	37.7	39.0	40.9
	S/T	0.76	0.69	0.56	0.4	0.76	0.69	0.56	0.4	1.00	0.72	0.59	0.4	1.00	0.73	0.60	0.5	3.00	2.76	2.63	2.5
	ΔT	23.65	21.74	18.18	14.5	23.59	21.69	18.13	14.4	23.86	21.96	18.40	14.7	23.58	21.67	18.11	14.4	23.32	21.41	17.86	14.2
	kW	2,814	2,811	2,805	2,831	3,156	3,154	3,148	3,174	3,539	3,536	3,530	3,556	3,953	3,950	3,944	3,970	4,415	4,413	4,407	4,433
	Amps	10.35	10.34	10.31	10.4	11.84	11.83	11.80	11.9	13.50	13.49	13.46	13.6	15.30	15.29	15.26	15.4	17.31	17.30	17.27	17.4
	Hi PR	265	266	268	272.6	306	308	309	314.0	350	351	353	357.4	397	398	400	404.2	447	448	450	454.6
Lo PR	124	126	129	134.2	132	133	136	141.6	138	140	143	148.2	144	145	148	153.7	149	151	154	159.1	
1500	MBh	43.9	44.5	45.8	47.7	43.6	44.1	45.4	47.3	42.4	43.0	44.3	46.2	40.6	41.1	42.4	44.3	38.2	38.8	40.1	42.0
	S/T	0.80	0.73	0.60	0.5	1.00	0.73	0.60	0.5	1.00	0.76	0.63	0.5	1.00	0.78	0.65	0.5	3.00	2.80	2.67	2.5
	ΔT	22.15	20.25	16.69	13.0	22.10	20.19	16.64	12.9	22.37	20.46	16.90	13.2	22.08	20.17	16.62	12.9	21.83	19.92	16.36	12.7
	kW	2,837	2,834	2,828	2,854	3,179	3,177	3,171	3,197	3,562	3,559	3,553	3,579	3,976	3,973	3,967	3,993	4,438	4,436	4,430	4,456
	Amps	10.45	10.44	10.41	10.5	11.94	11.93	11.90	12.0	13.60	13.59	13.56	13.7	15.40	15.39	15.36	15.5	17.41	17.40	17.37	17.5
	Hi PR	269	270	272	276.1	310	311	313	317.5	353	354	356	360.9	400	401	403	407.7	450	452	453	458.1
Lo PR	128	129	132	137.5	135	137	140	145.0	142	143	146	151.5	147	149	152	157.0	153	154	157	162.4	

IDB: Entering Indoor Dry Bulb Temperature
 High and low pressures are measured at the liquid and suction service valves.
 Shaded area reflects ACCA (TVA) conditions
 kW = Total system power
 Amps = outdoor unit amps (comp. + fan)

EXPANDED COOLING DATA — GPGM548***31 LOW STAGE

IDB	AIRFLOW	OUTDOOR AMBIENT TEMPERATURE												115°F											
		65°F			75°F			85°F			95°F				105°F										
		59	63	71	59	63	71	59	63	71	59	63	71		59	63	71								
		ENTERING INDOOR WET BULB TEMPERATURE																							
800	MBh	33.5	34.0	35.0	-	33.2	33.7	34.7	-	32.4	32.8	33.8	-	30.9	31.3	32.3	-	29.0	29.5	30.5	-	27.3	27.8	28.8	-
	S/T	0.56	0.49	0.36	-	0.57	0.49	0.36	-	0.59	0.52	0.39	-	1.00	0.54	0.41	-	1.00	0.56	0.43	-	1.00	0.61	0.48	-
	ΔT	21.38	19.43	15.80	-	21.32	19.38	15.75	-	21.60	19.65	16.02	-	21.30	19.36	15.73	-	21.04	19.10	15.47	-	22.26	20.32	16.69	-
	kW	1944	1942	1938	-	2184	2182	2178	-	2451	2450	2446	-	2741	2739	2735	-	3065	3063	3059	-	3445	3443	3439	-
	Amps	7.12	7.11	7.09	-	8.16	8.15	8.14	-	9.33	9.32	9.30	-	10.59	10.58	10.56	-	12.00	11.99	11.97	-	13.65	13.64	13.62	-
950	Hi PR	257	258	259	-	297	298	300	-	340	341	343	-	385	387	388	-	435	436	438	-	487	489	490	-
	Lo PR	124	126	129	-	132	133	136	-	138	140	143	-	144	145	149	-	149	151	154	-	156	158	161	-
	MBh	34.1	34.6	35.6	-	33.8	34.3	35.3	-	32.9	33.4	34.4	-	31.4	31.9	32.9	-	29.6	30.0	31.0	-	27.9	28.3	29.3	-
	S/T	0.64	0.57	0.44	-	0.64	0.57	0.44	-	0.67	0.60	0.47	-	1.00	0.61	0.48	-	1.00	0.64	0.51	-	1.00	0.68	0.55	-
	ΔT	19.85	17.90	14.27	-	19.80	17.85	14.22	-	20.07	18.12	14.49	-	19.78	17.83	14.20	-	19.52	17.57	13.94	-	20.73	18.79	15.16	-
1100	kW	1960	1958	1954	-	2200	2198	2194	-	2468	2466	2462	-	2758	2756	2752	-	3081	3080	3075	-	3461	3460	3455	-
	Amps	7.19	7.18	7.16	-	8.23	8.22	8.21	-	9.40	9.39	9.37	-	10.66	10.65	10.63	-	12.07	12.06	12.04	-	13.72	13.71	13.69	-
	Hi PR	259	260	262	-	300	301	303	-	342	344	345	-	388	389	391	-	438	439	441	-	490	491	493	-
	Lo PR	126	128	131	-	134	136	139	-	141	142	145	-	146	148	151	-	152	153	156	-	159	160	163	-
	MBh	34.8	35.3	36.3	-	34.5	35.0	36.0	-	33.6	34.1	35.1	-	32.1	32.6	33.6	-	30.2	30.7	31.7	-	28.6	29.0	30.0	-
800	S/T	0.68	0.60	0.47	-	0.68	0.61	0.48	-	1.00	0.63	0.50	-	1.00	0.65	0.52	-	1.00	0.67	0.54	-	1.00	0.72	0.59	-
	ΔT	18.62	16.68	13.05	-	18.57	16.62	12.99	-	18.84	16.90	13.27	-	18.55	16.60	12.97	-	18.29	16.34	12.71	-	19.50	17.56	13.93	-
	kW	1973	1971	1967	-	2213	2211	2207	-	2481	2479	2475	-	2771	2769	2765	-	3094	3093	3088	-	3474	3472	3468	-
	Amps	7.25	7.24	7.22	-	8.29	8.28	8.26	-	9.45	9.45	9.43	-	10.71	10.71	10.69	-	12.12	12.11	12.10	-	13.77	13.77	13.75	-
	Hi PR	262	263	265	-	303	304	306	-	345	346	348	-	391	392	394	-	440	441	443	-	493	494	496	-
950	Lo PR	129	131	134	-	137	138	141	-	143	145	148	-	149	150	154	-	154	156	159	-	161	163	166	-
	MBh	33.6	34.0	35.0	36.6	33.3	33.7	34.7	36.3	32.4	32.9	33.9	35.4	30.9	31.3	32.4	33.9	29.6	30.0	31.1	32.6	27.9	28.4	29.4	30.9
	S/T	0.76	0.69	0.56	0.4	1.00	0.70	0.57	0.4	1.00	0.72	0.59	0.5	1.00	0.74	0.61	0.5	1.00	0.76	0.63	0.5	1.00	1.00	0.68	0.5
	ΔT	24.12	22.18	18.55	14.8	24.07	22.13	18.50	14.7	24.34	22.40	18.77	15.0	24.05	22.11	18.48	14.7	23.79	21.85	18.22	14.5	25.01	23.06	19.43	15.7
	kW	1958	1956	1952	1971	2198	2196	2192	2211	2466	2464	2460	2478	2756	2754	2750	2768	3080	3078	3074	3092	3460	3458	3454	3472
75	Amps	7.18	7.17	7.16	7.2	8.23	8.22	8.20	8.3	9.39	9.38	9.36	9.4	10.65	10.64	10.62	10.7	12.06	12.05	12.03	12.1	13.71	13.70	13.68	13.8
	Hi PR	260	261	263	267.0	300	301	303	307.6	343	344	346	350.1	388	390	391	395.9	438	439	441	445.2	491	492	493	497.9
	Lo PR	126	128	131	136.4	134	136	139	144.0	141	142	145	150.7	146	148	151	156.3	152	153	156	161.8	159	160	163	168.7
	MBh	34.1	34.6	35.6	37.1	33.8	34.3	35.3	36.8	32.9	33.4	34.4	35.9	31.4	31.9	32.9	34.4	30.3	30.7	31.7	33.3	28.6	29.0	30.1	31.6
	S/T	0.80	0.73	0.60	0.5	1.00	0.73	0.60	0.5	1.00	0.76	0.63	0.5	1.00	0.78	0.65	0.5	1.00	1.00	0.67	0.5	1.00	1.00	0.72	0.6
1100	ΔT	22.89	20.95	17.32	13.6	22.84	20.90	17.27	13.5	23.11	21.17	17.54	13.8	22.82	20.88	17.25	13.5	22.56	20.62	16.99	13.2	23.78	21.83	18.20	14.4
	kW	1971	1969	1965	1984	2211	2209	2205	2224	2479	2477	2473	2491	2769	2767	2763	2781	3093	3091	3087	3105	3473	3471	3467	3485
	Amps	7.24	7.23	7.21	7.3	8.28	8.27	8.26	8.3	9.45	9.44	9.42	9.5	10.71	10.70	10.68	10.8	12.12	12.11	12.09	12.2	13.77	13.76	13.74	13.8
	Hi PR	262	263	265	269.7	303	304	306	310.3	345	346	348	352.8	391	392	394	398.6	441	442	443	447.9	493	494	496	500.6
	Lo PR	129	131	134	139.1	137	138	141	146.6	143	145	148	153.3	149	150	154	158.9	154	156	159	164.4	161	163	166	171.3

IDB: Entering Indoor Dry Bulb Temperature
 High and low pressures are measured at the liquid and suction service valves.
 Shaded area reflects ACCA (TVA) conditions
 kW = Total system power
 Amps = outdoor unit amps (comp.+fan)

EXPANDED COOLING DATA — GPGM548***31 HIGH STAGE

IDB	AIRFLOW	OUTDOOR AMBIENT TEMPERATURE																								
		65°F			75°F			85°F			95°F			105°F			115°F									
		59	63	67	71	59	63	67	71	59	63	67	71	59	63	67	71	59	63	67	71					
70	1000	MBh	46.4	47.0	48.4	-	45.9	46.6	48.0	-	44.7	45.4	46.8	-	42.6	43.3	44.7	-	40.0	40.7	42.1	-	37.7	38.4	39.8	-
		S/T	0.49	0.42	0.30	-	0.50	0.43	0.30	-	0.52	0.45	0.33	-	0.54	0.47	0.34	-	1.00	0.49	0.37	-	1.00	0.54	0.41	-
		ΔT	23.05	21.04	17.28	-	23.00	20.99	17.22	-	23.28	21.27	17.51	-	22.98	20.96	17.20	-	22.71	20.70	16.93	-	23.97	21.96	18.19	-
		kW	3075	3072	3066	-	3457	3454	3447	-	3883	3880	3873	-	4344	4341	4334	-	4858	4855	4849	-	5463	5460	5453	-
		Amps	11.25	11.24	11.21	-	12.91	12.90	12.87	-	14.76	14.75	14.72	-	16.77	16.75	16.73	-	19.01	18.99	18.96	-	21.63	21.62	21.59	-
	Hi PR	267	268	270	-	309	311	312	-	354	355	357	-	402	403	405	-	453	454	456	-	508	510	511	-	
	Lo PR	120	121	124	-	127	129	132	-	134	135	138	-	139	141	144	-	144	146	149	-	151	153	156	-	
	MBh	47.4	48.1	49.5	-	47.0	47.7	49.1	-	45.8	46.4	47.8	-	43.7	44.3	45.7	-	41.1	41.8	43.2	-	38.8	39.4	40.8	-	
	S/T	0.62	0.55	0.42	-	0.63	0.56	0.43	-	0.65	0.58	0.45	-	0.67	0.60	0.47	-	1.00	0.62	0.49	-	1.00	0.67	0.54	-	
	ΔT	20.57	18.55	14.79	-	20.51	18.50	14.74	-	20.80	18.78	15.02	-	20.49	18.48	14.72	-	20.22	18.21	14.45	-	21.48	19.47	15.71	-	
kW	3116	3113	3106	-	3497	3494	3488	-	3923	3920	3914	-	4384	4381	4375	-	4899	4896	4889	-	5503	5500	5494	-		
Amps	11.43	11.42	11.39	-	13.09	13.08	13.05	-	14.94	14.93	14.90	-	16.94	16.93	16.90	-	19.18	19.17	19.14	-	21.81	21.80	21.77	-		
Hi PR	271	272	274	-	314	315	317	-	358	359	361	-	406	407	409	-	458	459	461	-	513	514	516	-		
Lo PR	123	124	128	-	130	132	135	-	137	138	141	-	142	144	147	-	148	149	152	-	154	156	159	-		
MBh	48.9	49.6	51.0	-	48.5	49.1	50.5	-	47.3	47.9	49.3	-	45.1	45.8	47.2	-	42.6	43.2	44.6	-	40.2	40.9	42.3	-		
S/T	0.66	0.59	0.47	-	0.67	0.60	0.47	-	0.69	0.62	0.50	-	1.00	0.64	0.51	-	1.00	0.66	0.53	-	1.00	0.71	0.58	-		
ΔT	18.77	16.75	12.99	-	18.71	16.70	12.94	-	19.00	16.98	13.22	-	18.69	16.68	12.92	-	18.42	16.41	12.65	-	19.69	17.67	13.91	-		
kW	3145	3142	3135	-	3526	3523	3517	-	3952	3949	3943	-	4413	4410	4404	-	4928	4925	4918	-	5532	5529	5523	-		
Amps	11.56	11.54	11.51	-	13.21	13.20	13.17	-	15.07	15.05	15.02	-	17.07	17.06	17.03	-	19.31	19.30	19.27	-	21.94	21.92	21.89	-		
Hi PR	275	277	278	-	318	319	321	-	362	364	365	-	410	411	413	-	462	463	465	-	517	518	520	-		
Lo PR	127	128	131	-	134	136	139	-	141	142	145	-	146	148	151	-	151	153	156	-	158	160	163	-		

75	1000	MBh	46.4	47.0	48.4	50.6	46.0	46.6	48.0	50.2	44.7	45.4	46.8	48.9	42.6	43.3	44.7	46.8	40.1	40.7	42.1	44.3	37.7	38.4	39.8	41.9
		S/T	0.62	0.54	0.42	0.3	0.62	0.55	0.42	0.3	1.00	0.57	0.45	0.3	1.00	0.59	0.47	0.3	1.00	0.61	0.49	0.4	1.00	0.66	0.53	0.4
		ΔT	27.48	25.47	21.71	17.8	27.43	25.41	21.65	17.8	27.71	25.70	21.94	18.0	27.41	25.39	21.63	17.7	27.14	25.12	21.36	17.5	28.40	26.39	22.62	18.7
		kW	3073	3070	3063	3093	3454	3451	3445	3474	3880	3877	3871	3900	4341	4338	4332	4361	4856	4853	4846	4876	5460	5457	5451	5480
		Amps	11.24	11.23	11.20	11.3	12.90	12.89	12.86	13.0	14.75	14.74	14.71	14.8	16.76	16.74	16.72	16.8	19.00	18.98	18.95	19.1	21.62	21.61	21.58	21.7
	Hi PR	267	268	270	274.9	310	311	313	317.3	354	355	357	361.8	402	403	405	409.7	454	455	457	461.3	509	510	512	516.4	
	Lo PR	120	121	124	129.5	127	129	132	136.9	134	135	138	143.3	139	141	144	148.8	144	146	149	154.2	151	153	156	160.9	
	MBh	47.4	48.1	49.5	51.6	47.0	47.7	49.1	51.2	45.8	46.5	47.9	50.0	43.7	44.4	45.8	47.9	41.1	41.8	43.2	45.3	38.8	39.4	40.8	43.0	
	S/T	0.74	0.67	0.54	0.4	0.75	0.68	0.55	0.4	1.00	0.70	0.57	0.4	1.00	0.72	0.59	0.5	1.00	0.74	0.61	0.5	1.00	0.80	0.66	0.5	
	ΔT	25.00	22.98	19.22	15.3	24.94	22.93	19.17	15.3	25.23	23.21	19.45	15.6	24.92	22.91	19.15	15.2	24.65	22.64	18.88	15.0	25.91	23.90	20.14	16.2	
kW	3113	3110	3104	3133	3495	3492	3485	3515	3921	3918	3911	3940	4382	4379	4372	4401	4896	4893	4887	4916	5501	5498	5491	5520		
Amps	11.42	11.41	11.38	11.5	13.08	13.06	13.04	13.2	14.93	14.92	14.89	15.0	16.93	16.92	16.89	17.0	19.17	19.16	19.13	19.3	21.80	21.78	21.76	21.9		
Hi PR	272	273	275	279.3	314	315	317	321.7	358	360	362	366.2	406	408	409	414.1	458	459	461	465.7	513	514	516	520.8		
Lo PR	123	124	128	132.7	130	132	135	140.1	137	138	141	146.6	142	144	147	152.0	148	149	152	157.4	154	156	159	164.1		
MBh	48.9	49.6	51.0	53.1	48.5	49.2	50.6	52.7	47.3	47.9	49.3	51.5	45.2	45.8	47.2	49.4	42.6	43.3	44.7	46.8	40.3	40.9	42.3	44.5		
S/T	0.78	0.71	0.59	0.5	1.00	0.72	0.59	0.5	1.00	0.74	0.62	0.5	1.00	0.76	0.63	0.5	1.00	0.78	0.65	0.5	1.00	0.90	0.70	0.6		
ΔT	23.20	21.18	17.42	13.5	23.14	21.13	17.37	13.5	23.43	21.41	17.65	13.8	23.12	21.11	17.35	13.4	22.85	20.84	17.08	13.2	24.12	22.10	18.34	14.4		
kW	3142	3139	3133	3162	3524	3521	3514	3544	3950	3947	3940	3969	4411	4408	4401	4430	4926	4923	4916	4945	5530	5527	5520	5549		
Amps	11.55	11.53	11.50	11.6	13.20	13.19	13.16	13.3	15.06	15.04	15.01	15.1	17.06	17.05	17.02	17.1	19.30	19.28	19.26	19.4	21.92	21.91	21.88	22.0		
Hi PR	276	277	279	283.4	318	319	321	325.9	363	364	366	370.3	410	412	414	418.2	462	463	465	469.9	517	518	520	525.0		
Lo PR	127	128	131	136.6	134	136	139	144.0	141	142	145	150.4	146	148	151	155.9	151	153	156	161.2	158	160	163	167.9		

IDB: Entering Indoor Dry Bulb Temperature
 High and low pressures are measured at the liquid and suction service valves.
 Shaded area reflects ACCA (TVA) conditions
 kW = Total system power
 Amps = outdoor unit amps (comp. + fan)

EXPANDED COOLING DATA — GPGM560***31 LOW STAGE

IDB	AIRFLOW	OUTDOOR AMBIENT TEMPERATURE												ENTERING INDOOR WET BULB TEMPERATURE											
		65°F				75°F				85°F				95°F				105°F				115°F			
		59	63	67	71	59	63	67	71	59	63	67	71	59	63	67	71	59	63	67	71	59	63	67	71
70	MBh	43.0	43.7	44.9	-	42.7	43.3	44.6	-	41.5	42.1	43.4	-	39.6	40.2	41.5	-	37.2	37.8	39.1	-	35.1	35.7	37.0	-
	S/T	0.59	0.51	0.38	-	0.59	0.52	0.38	-	0.62	0.54	0.41	-	1.00	0.56	0.43	-	1.00	0.59	0.45	-	1.00	0.64	0.50	-
	ΔT	18.89	17.17	13.95	-	18.85	17.12	13.91	-	19.09	17.37	14.15	-	18.83	17.11	13.89	-	18.60	16.88	13.66	-	19.68	17.95	14.74	-
	kW	2145	2143	2138	-	2409	2407	2402	-	2704	2702	2697	-	3023	3021	3016	-	3379	3377	3372	-	3797	3795	3791	-
	Amps	7.62	7.62	7.60	-	8.77	8.76	8.74	-	10.05	10.05	10.03	-	11.44	11.43	11.41	-	12.99	12.98	12.96	-	14.81	14.80	14.78	-
Hi PR	251	252	254	-	291	292	294	-	333	334	336	-	377	379	380	-	426	427	429	-	477	478	480	-	
Lo PR	127	129	132	-	135	137	140	-	142	144	147	-	148	149	153	-	153	155	158	-	160	162	165	-	
MBh	43.7	44.3	45.6	-	43.3	43.9	45.2	-	42.2	42.8	44.1	-	40.3	40.9	42.2	-	37.9	38.5	39.8	-	35.7	36.3	37.6	-	
S/T	0.67	0.59	0.45	-	0.67	0.60	0.46	-	1.00	0.62	0.49	-	1.00	0.64	0.51	-	1.00	0.66	0.53	-	1.00	1.00	0.58	-	
ΔT	17.58	15.86	12.65	-	17.54	15.82	12.60	-	17.78	16.06	12.84	-	17.52	15.80	12.58	-	17.29	15.57	12.35	-	18.37	16.65	13.43	-	
kW	2162	2160	2155	-	2426	2424	2420	-	2721	2719	2714	-	3040	3038	3033	-	3396	3394	3390	-	3814	3812	3808	-	
Amps	7.70	7.69	7.67	-	8.85	8.84	8.82	-	10.13	10.12	10.10	-	11.52	11.51	11.49	-	13.07	13.06	13.04	-	14.88	14.87	14.85	-	
Hi PR	254	255	257	-	294	295	297	-	335	336	338	-	380	381	383	-	428	430	431	-	480	481	483	-	
Lo PR	130	131	135	-	137	139	142	-	144	146	149	-	150	152	155	-	156	157	161	-	163	164	168	-	
MBh	46.5	47.1	48.4	-	46.1	46.7	48.0	-	45.0	45.6	46.9	-	43.1	43.7	45.0	-	40.7	41.3	42.6	-	38.5	39.1	40.4	-	
S/T	0.70	0.62	0.48	-	1.00	0.63	0.49	-	1.00	0.65	0.52	-	1.00	0.67	0.53	-	1.00	1.00	0.56	-	1.00	1.00	0.61	-	
ΔT	15.01	13.29	10.07	-	14.96	13.24	10.02	-	15.20	13.48	10.26	-	14.94	13.22	10.00	-	14.71	12.99	9.77	-	15.79	14.07	10.85	-	
kW	2196	2194	2189	-	2460	2458	2453	-	2755	2752	2748	-	3073	3071	3067	-	3430	3428	3423	-	3848	3846	3841	-	
Amps	7.85	7.84	7.82	-	8.99	8.98	8.96	-	10.28	10.27	10.25	-	11.66	11.65	11.63	-	13.21	13.20	13.18	-	15.03	15.02	15.00	-	
Hi PR	261	262	264	-	301	302	304	-	342	344	345	-	387	388	390	-	436	437	438	-	487	488	490	-	
Lo PR	138	139	143	-	146	147	150	-	152	154	157	-	158	160	163	-	164	165	169	-	171	172	176	-	

1050	MBh	43.1	43.7	45.0	46.9	42.7	43.3	44.6	46.6	41.6	42.2	43.5	45.4	39.6	40.2	41.5	43.5	37.2	37.9	39.1	41.1	35.1	35.7	37.0	39.0
	S/T	0.72	0.64	0.51	0.4	1.00	0.65	0.51	0.4	1.00	0.67	0.54	0.4	1.00	0.69	0.56	0.4	1.00	1.00	0.58	0.4	1.00	1.00	0.63	0.5
	ΔT	22.68	20.96	17.74	14.4	22.63	20.91	17.69	14.4	22.87	21.15	17.94	14.6	22.62	20.89	17.68	14.3	22.39	20.66	17.45	14.1	23.46	21.74	18.52	15.2
	kW	2143	2141	2137	2157	2407	2405	2401	2421	2702	2700	2695	2716	3021	3019	3014	3035	3377	3375	3371	3391	3795	3793	3789	3809
	Amps	7.62	7.61	7.59	7.7	8.77	8.76	8.74	8.8	10.05	10.04	10.02	10.1	11.43	11.42	11.40	11.5	12.98	12.97	12.95	13.0	14.80	14.79	14.77	14.9
Hi PR	252	253	254	258.8	291	292	294	298.5	333	334	336	340.1	378	379	381	384.9	426	427	429	433.3	478	479	480	484.8	
Lo PR	127	129	132	137.7	135	137	140	145.5	142	144	147	152.3	148	149	153	158.1	153	155	158	163.7	161	162	165	170.8	
MBh	43.8	44.4	45.6	47.6	43.4	44.0	45.3	47.2	42.2	42.8	44.1	46.1	40.3	40.9	42.2	44.2	37.9	38.5	39.8	41.8	35.8	36.4	37.7	39.6	
S/T	0.80	0.72	0.58	0.4	1.00	0.73	0.59	0.4	1.00	0.75	0.62	0.5	1.00	0.77	0.63	0.5	1.00	1.00	0.66	0.5	1.00	1.00	0.71	0.6	
ΔT	21.37	19.65	16.43	13.1	21.32	19.60	16.39	13.1	21.57	19.84	16.63	13.3	21.31	19.58	16.37	13.0	21.08	19.35	16.14	12.8	22.16	20.43	17.22	13.9	
kW	2160	2158	2154	2174	2424	2422	2418	2438	2719	2717	2713	2733	3038	3036	3032	3052	3395	3392	3388	3408	3813	3811	3806	3826	
Amps	7.69	7.68	7.66	7.8	8.84	8.83	8.81	8.9	10.12	10.11	10.09	10.2	11.51	11.50	11.48	11.6	13.06	13.05	13.03	13.1	14.88	14.87	14.85	14.9	
Hi PR	254	255	257	261.4	294	295	297	301.1	336	337	338	342.8	380	381	383	387.6	429	430	432	435.9	480	481	483	487.5	
Lo PR	130	131	135	140.0	138	139	142	147.8	144	146	149	154.6	150	152	155	160.4	156	157	161	166.0	163	164	168	173.1	
MBh	46.5	47.2	48.4	50.4	46.2	46.8	48.1	50.0	45.0	45.6	46.9	48.9	43.1	43.7	45.0	47.0	40.7	41.3	42.6	44.6	38.6	39.2	40.5	42.4	
S/T	1.00	0.75	0.61	0.5	1.00	0.75	0.62	0.5	1.00	0.78	0.64	0.5	1.00	1.00	0.66	0.5	1.00	1.00	0.69	0.5	1.00	1.00	0.71	0.6	
ΔT	18.79	17.07	13.86	10.5	18.75	17.03	13.81	10.5	18.99	17.27	14.05	10.7	18.73	17.01	13.79	10.5	18.50	16.78	13.56	10.2	19.58	17.86	14.64	11.3	
kW	2194	2192	2187	2208	2458	2456	2451	2472	2753	2751	2746	2766	3072	3070	3065	3085	3428	3426	3422	3442	3846	3844	3840	3860	
Amps	7.84	7.83	7.81	7.9	8.99	8.98	8.96	9.0	10.27	10.26	10.24	10.3	11.65	11.65	11.63	11.7	13.20	13.20	13.18	13.3	15.02	15.01	14.99	15.1	
Hi PR	261	262	264	268.6	301	302	304	308.3	343	344	346	349.9	387	389	390	394.7	436	437	439	443.1	487	488	490	494.6	
Lo PR	138	139	143	148.1	146	147	150	155.8	152	154	157	162.7	158	160	163	168.4	164	165	169	174.1	171	172	176	181.1	

IDB: Entering Indoor Dry Bulb Temperature
 High and low pressures are measured at the liquid and suction service valves.
 Shaded area reflects ACCA (TVA) conditions
 kW = Total system power
 Amps = outdoor unit amps (comp. fan)

EXPANDED COOLING DATA — GPGM560***31 LOW STAGE (CONT.)

IDB		OUTDOOR AMBIENT TEMPERATURE												ENTERING INDOOR WET BULB TEMPERATURE												
		65°F				75°F				85°F				95°F				105°F				115°F				
		59	63	67	71	59	63	67	71	59	63	67	71	59	63	67	71	59	63	67	71	59	63	67	71	
80	AIRFLOW	MBh	43.3	43.9	45.2	47.2	42.9	43.5	44.8	46.8	41.8	42.4	43.7	45.6	39.8	40.4	41.7	43.7	37.5	38.1	39.4	41.3	35.3	35.9	37.2	39.2
		S/T	1.00	0.77	0.63	0.5	1.00	0.77	0.64	0.5	1.00	0.80	0.66	0.5	1.00	1.00	0.68	0.5	1.00	1.00	0.70	0.6	1.00	1.00	0.76	0.6
	ΔT	26.49	24.77	21.55	18.2	26.45	24.72	21.51	18.2	26.69	24.97	21.75	18.4	26.43	24.71	21.49	18.2	26.20	24.48	21.26	17.9	27.28	25.55	22.34	19.0	
	kW	2145	2142	2138	2158	2409	2407	2402	2422	2705	2701	2697	2717	3022	3020	3016	3036	3379	3377	3372	3392	3797	3795	3790	3810	
	Amps	7.62	7.61	7.59	7.7	8.77	8.76	8.74	8.8	10.05	10.04	10.02	10.1	11.44	11.43	11.41	11.5	12.99	12.98	12.96	13.0	14.81	14.80	14.78	14.9	
	Hi PR	252	253	255	259.2	292	293	295	299.0	333	334	336	340.6	378	379	381	385.4	426	428	429	433.7	478	479	481	485.3	
	Lo PR	128	130	133	138.3	136	137	141	146.1	143	144	147	152.9	148	150	153	158.6	154	156	159	164.3	161	163	166	171.4	
	MBh	44.0	44.6	45.9	47.8	43.6	44.2	45.5	47.5	42.5	43.1	44.4	46.3	40.5	41.1	42.4	44.4	38.2	38.8	40.1	42.0	36.0	36.6	37.9	39.9	
	S/T	1.00	0.85	0.71	0.6	1.00	0.85	0.72	0.6	1.00	1.00	0.74	0.6	1.00	1.00	0.76	0.6	1.00	1.00	0.78	0.6	1.00	1.00	1.00	0.7	
	ΔT	25.18	23.46	20.25	16.9	25.14	23.42	20.20	16.9	25.38	23.66	20.44	17.1	25.12	23.40	20.18	16.8	24.89	23.17	19.95	16.6	25.97	24.25	21.03	17.7	
kW	2162	2160	2155	2175	2426	2424	2419	2439	2721	2718	2714	2734	3040	3037	3033	3053	3396	3394	3389	3410	3814	3812	3808	3828		
Amps	7.70	7.69	7.67	7.8	8.85	8.84	8.82	8.9	10.13	10.12	10.10	10.2	11.51	11.51	11.49	11.6	13.06	13.05	13.04	13.1	14.88	14.87	14.85	14.9		
Hi PR	255	256	257	261.9	294	295	297	301.6	336	337	339	343.2	381	382	384	388.0	429	430	432	436.4	481	482	484	487.9		
Lo PR	130	132	135	140.6	138	140	143	148.4	145	146	150	155.2	151	152	155	160.9	156	158	161	166.6	163	165	168	173.7		
MBh	46.8	47.4	48.7	50.6	46.4	47.0	48.3	50.2	45.3	45.9	47.1	49.1	43.3	43.9	45.2	47.2	40.9	41.6	42.8	44.8	38.8	39.4	40.7	42.6		
S/T	1.00	0.87	0.74	0.6	1.00	1.00	0.74	0.6	1.00	1.00	0.77	0.6	1.00	1.00	0.79	0.6	1.00	1.00	1.00	0.7	1.00	1.00	1.00	0.7		
ΔT	22.61	20.89	17.67	14.3	22.56	20.84	17.62	14.3	22.80	21.08	17.86	14.5	22.54	20.82	17.60	14.3	22.31	20.59	17.37	14.0	23.39	21.67	18.45	15.1		
kW	2195	2193	2189	2209	2459	2457	2453	2473	2754	2752	2748	2768	3073	3071	3067	3087	3430	3427	3423	3443	3848	3846	3841	3861		
Amps	7.84	7.83	7.82	7.9	8.99	8.98	8.96	9.1	10.27	10.26	10.24	10.3	11.66	11.65	11.63	11.7	13.21	13.20	13.18	13.3	15.03	15.02	15.00	15.1		
Hi PR	262	263	265	269.0	302	303	304	308.8	343	344	346	350.4	388	389	391	395.2	436	437	439	443.5	488	489	491	495.1		
Lo PR	138	140	143	148.6	146	148	151	156.4	153	155	158	163.2	159	160	164	169.0	164	166	169	174.6	171	173	176	181.7		

85	AIRFLOW	MBh	44.0	44.6	45.9	47.9	43.6	44.2	45.5	47.5	42.5	43.1	44.4	46.4	40.6	41.2	42.5	44.4	38.2	38.8	40.1	42.1	36.0	36.6	37.9	39.9
		S/T	1.00	0.87	0.73	0.6	1.00	1.00	0.74	0.6	1.00	1.00	0.76	0.6	1.00	1.00	0.78	0.6	1.00	1.00	1.00	0.7	1.00	1.00	1.00	0.7
	ΔT	29.87	28.15	24.94	21.6	29.83	28.11	24.89	21.6	30.07	28.35	25.13	21.8	29.81	28.09	24.87	21.5	29.58	27.86	24.64	21.3	30.66	28.94	25.72	22.4	
	kW	2150	2147	2143	2163	2414	2412	2407	2427	2708	2706	2702	2722	3027	3025	3021	3041	3384	3382	3377	3397	3802	3800	3795	3816	
	Amps	7.64	7.64	7.62	7.7	8.79	8.78	8.76	8.9	10.07	10.07	10.05	10.1	11.46	11.45	11.43	11.5	13.01	13.00	12.98	13.1	14.83	14.82	14.80	14.9	
	Hi PR	253	254	256	260.4	293	294	296	300.1	335	336	337	341.8	379	380	382	386.6	428	429	431	434.9	479	480	482	486.5	
	Lo PR	130	132	135	140.2	138	139	143	148.0	145	146	149	154.8	150	152	155	160.6	156	158	161	166.2	163	165	168	173.3	
	MBh	44.7	45.3	46.6	48.6	44.3	44.9	46.2	48.2	43.2	43.8	45.1	47.1	41.2	41.9	43.1	45.1	38.9	39.5	40.8	42.7	36.7	37.3	38.6	40.6	
	S/T	1.00	0.95	0.81	0.7	1.00	1.00	0.82	0.7	1.00	1.00	0.84	0.7	1.00	1.00	0.86	0.7	1.00	1.00	1.00	0.7	1.00	1.00	1.00	0.8	
	ΔT	28.57	26.84	23.63	20.3	28.52	26.80	23.58	20.2	28.76	27.04	23.82	20.5	28.50	26.78	23.56	20.2	28.27	26.55	23.33	20.0	29.35	27.63	24.41	21.1	
kW	2167	2165	2160	2180	2431	2429	2424	2444	2726	2724	2719	2739	3045	3043	3038	3058	3401	3399	3394	3415	3819	3817	3813	3833		
Amps	7.72	7.71	7.69	7.8	8.87	8.86	8.84	8.9	10.15	10.14	10.12	10.2	11.54	11.53	11.51	11.6	13.09	13.08	13.06	13.1	14.90	14.89	14.88	15.0		
Hi PR	256	257	259	263.1	296	297	298	302.8	337	338	340	344.4	382	383	385	389.2	430	431	433	437.6	482	483	485	489.1		
Lo PR	132	134	137	142.5	140	142	145	150.3	147	148	152	157.1	153	154	157	162.8	158	160	163	168.5	165	167	170	175.6		
MBh	47.5	48.1	49.4	51.4	47.1	47.7	49.0	51.0	46.0	46.6	47.9	49.8	44.0	44.6	45.9	47.9	41.7	42.3	43.6	45.5	39.5	40.1	41.4	43.4		
S/T	1.00	1.00	0.84	0.7	1.00	1.00	0.85	0.7	1.00	1.00	1.00	0.7	1.00	1.00	1.00	0.7	1.00	1.00	1.00	0.8	1.00	1.00	1.00	1.0		
ΔT	25.99	24.27	21.05	17.7	25.94	24.22	21.00	17.7	26.18	24.46	21.25	17.9	25.93	24.20	20.99	17.7	25.69	23.97	20.76	17.4	26.77	25.05	21.83	18.5		
kW	2200	2198	2194	2214	2464	2462	2458	2478	2759	2757	2753	2773	3078	3076	3072	3092	3435	3433	3428	3448	3853	3851	3846	3866		
Amps	7.87	7.86	7.84	7.9	9.01	9.00	8.99	9.1	10.30	10.29	10.27	10.4	11.68	11.67	11.65	11.7	13.23	13.22	13.20	13.3	15.05	15.04	15.02	15.1		
Hi PR	263	264	266	270.2	303	304	306	310.0	344	345	347	351.6	389	390	392	396.4	437	439	440	444.7	489	490	492	496.3		
Lo PR	140	142	145	150.5	148	150	153	158.3	155	156	160	165.1	161	162	165	170.9	166	168	171	176.5	173	175	178	183.6		

IDB: Entering Indoor Dry Bulb Temperature
 High and low pressures are measured at the liquid and suction service valves.
 Shaded area reflects AHRI (TVA) conditions
 kW = Total system power
 Amps = outdoor unit amps (comp.+fan)

EXPANDED COOLING DATA — GPGM560***31 HIGH STAGE

IDB	AIRFLOW	OUTDOOR AMBIENT TEMPERATURE																								
		65°F				75°F				85°F				95°F				105°F				115°F				
		59	63	67	71	59	63	67	71	59	63	67	71	59	63	67	71	59	63	67	71	59	63	67	71	
70	1500	MBh	59.6	60.5	62.2	-	59.1	59.9	61.7	-	57.5	58.3	60.1	-	54.8	55.6	57.4	-	51.5	52.4	54.1	-	48.5	49.3	51.1	-
		S/T	0.54	0.46	0.33	-	0.55	0.47	0.34	-	0.57	0.50	0.36	-	0.59	0.51	0.38	-	1.00	0.54	0.40	-	1.00	0.59	0.45	-
		ΔT	20.10	18.31	14.98	-	20.05	18.26	14.93	-	20.30	18.51	15.18	-	20.03	18.24	14.91	-	19.79	18.01	14.67	-	20.91	19.12	15.79	-
		kW	3.40	3.40	3.39	-	3.82	3.82	3.81	-	4.29	4.28	4.28	-	4.80	4.79	4.78	-	5.36	5.36	5.35	-	6.03	6.02	6.02	-
		Amps	12.08	12.06	12.03	-	13.90	13.89	13.86	-	15.94	15.92	15.89	-	18.14	18.13	18.10	-	20.61	20.59	20.56	-	23.50	23.48	23.45	-
	1880	Hi PR	262	263	265	-	303	305	306	-	347	348	350	-	394	395	397	-	444	446	447	-	498	500	501	-
		Lo PR	123	125	128	-	131	132	136	-	137	139	142	-	143	145	148	-	149	150	153	-	155	157	160	-
		MBh	60.8	61.7	63.5	-	60.3	61.1	62.9	-	58.7	59.6	61.4	-	56.0	56.9	58.7	-	52.7	53.6	55.4	-	49.7	50.6	52.3	-
		S/T	0.65	0.57	0.44	-	0.66	0.58	0.45	-	0.68	0.61	0.47	-	1.00	0.62	0.49	-	1.00	0.65	0.51	-	1.00	0.70	0.56	-
		ΔT	18.22	16.44	13.10	-	18.17	16.39	13.06	-	18.42	16.64	13.31	-	18.16	16.37	13.04	-	17.92	16.13	12.80	-	19.03	17.25	13.92	-
2500	kW	3.44	3.43	3.43	-	3.86	3.85	3.85	-	4.33	4.32	4.32	-	4.83	4.83	4.82	-	5.40	5.40	5.39	-	6.06	6.06	6.05	-	
	Amps	12.24	12.23	12.19	-	14.07	14.05	14.02	-	16.10	16.09	16.06	-	18.31	18.29	18.26	-	20.77	20.76	20.73	-	23.66	23.65	23.62	-	
	Hi PR	266	267	269	-	307	308	310	-	351	352	354	-	398	399	401	-	448	449	451	-	502	503	505	-	
	Lo PR	126	128	131	-	134	135	138	-	140	142	145	-	146	148	151	-	151	153	156	-	158	160	163	-	
	MBh	63.7	64.6	66.4	-	63.2	64.0	65.8	-	61.6	62.5	64.3	-	58.9	59.8	61.6	-	55.6	56.5	58.3	-	52.6	53.5	55.3	-	

75	1500	MBh	59.6	60.5	62.3	65.0	59.1	59.9	61.7	64.5	57.5	58.4	60.2	62.9	54.8	55.7	57.5	60.2	51.5	52.4	54.2	56.9	48.5	49.4	51.2	53.9
		S/T	0.67	0.59	0.46	0.3	0.67	0.60	0.46	0.3	1.00	0.62	0.49	0.3	1.00	0.64	0.51	0.4	23.95	22.17	18.84	15.4	24.83	23.05	19.71	16.3
		ΔT	24.02	22.24	18.90	15.5	23.97	22.19	18.85	15.4	24.22	22.44	19.11	15.7	4.79	4.79	4.78	4.8	20.60	20.58	20.55	20.7	23.49	23.47	23.44	23.6
		kW	3.40	3.39	3.39	3.4	3.82	3.81	3.81	3.8	4.29	4.28	4.27	4.3	4.83	4.83	4.82	4.9	5.36	5.36	5.35	5.4	6.02	6.02	6.01	6.0
		Amps	12.06	12.05	12.02	12.2	13.89	13.87	13.84	14.0	15.93	15.91	15.88	16.0	18.13	18.12	18.09	18.2	20.60	20.58	20.55	20.7	23.49	23.47	23.44	23.6
	1880	Hi PR	262	263	265	269.7	304	305	307	311.3	347	348	350	354.8	394	395	397	401.7	445	446	448	452.2	499	500	502	506.2
		Lo PR	123	125	128	133.3	131	132	136	140.9	137	139	142	147.5	143	145	148	153.1	149	150	153	158.6	155	157	160	165.5
		MBh	60.8	61.7	63.5	66.2	60.3	61.2	63.0	65.7	58.7	59.6	61.4	64.1	56.0	56.9	58.7	61.4	52.8	53.6	55.4	58.1	49.7	50.6	52.4	55.1
		S/T	0.77	0.70	0.57	0.4	1.00	0.71	0.57	0.4	1.00	0.73	0.60	0.5	1.00	0.75	0.62	0.5	1.00	0.77	0.64	0.5	1.00	1.00	0.69	0.6
		ΔT	22.15	20.36	17.03	13.6	22.10	20.31	16.98	13.5	22.35	20.56	17.23	13.8	22.08	20.29	16.96	13.5	21.84	20.06	16.72	13.3	22.96	21.17	17.84	14.4
2500	kW	3.43	3.43	3.42	3.5	3.85	3.85	3.84	3.9	4.32	4.32	4.31	4.3	4.83	4.83	4.82	4.9	5.40	5.39	5.39	5.4	6.06	6.06	6.05	6.1	
	Amps	12.23	12.21	12.18	12.3	14.05	14.04	14.01	14.1	16.09	16.08	16.05	16.2	18.30	18.28	18.25	18.4	20.76	20.75	20.71	20.9	23.65	23.64	23.60	23.7	
	Hi PR	266	267	269	273.4	307	309	310	315.0	351	352	354	358.5	398	399	401	405.4	448	450	451	456.0	502	503	505	509.9	
	Lo PR	126	128	131	136.2	134	135	138	143.8	140	142	145	150.4	146	148	151	156.0	151	153	156	161.5	158	160	163	168.4	
	MBh	63.8	64.6	66.4	69.2	63.2	64.1	65.9	68.6	61.7	62.5	64.3	67.0	59.0	59.8	61.6	64.4	55.7	56.5	58.3	61.1	52.7	53.5	55.3	58.0	

IDB: Entering Indoor Dry Bulb Temperature
 High and low pressures are measured at the liquid and suction service valves.
 Shaded area reflects ACCA (TVA) conditions
 kW = Total system power
 Amps = outdoor unit amps (comp.+fan)

EXPANDED COOLING DATA — GPGM560***31 HIGH STAGE (CONT.)

IDB		OUTDOOR AMBIENT TEMPERATURE															115°F																		
		65°F					75°F					85°F					95°F					105°F					115°F								
		59	63	67	71	75	59	63	67	71	75	59	63	67	71	75	59	63	67	71	75	59	63	67	71	75	59	63	67	71	75				
		ENTERING INDOOR WET BULB TEMPERATURE																																	
		AIRFLOW																																	
1500	MBh	59.9	60.8	62.6	65.3	59.4	60.3	62.1	64.8	57.8	58.7	60.5	63.2	55.1	56.0	57.8	60.5	51.9	52.7	54.5	57.2	48.8	49.7	51.5	54.2	51.9	52.7	54.5	57.2	48.8	49.7	51.5	54.2		
	S/T	1.00	0.71	0.58	0.4	1.00	0.72	0.59	0.4	1.00	0.74	0.61	0.5	1.00	0.76	0.63	0.5	1.00	1.00	1.00	0.65	0.5	1.00	1.00	0.70	0.6	1.00	1.00	1.00	0.65	0.5	1.00	1.00	0.70	0.6
	ΔT	27.97	26.19	22.85	19.4	27.92	26.14	22.81	19.4	28.17	26.39	23.06	19.6	27.90	26.12	22.79	19.3	27.67	25.88	22.55	19.1	28.78	27.00	23.67	20.2	27.67	25.88	22.55	19.1	28.78	27.00	23.67	20.2		
	kW	3.40	3.40	3.40	3.39	3.82	3.82	3.81	3.8	4.29	4.28	4.28	4.3	4.79	4.79	4.78	4.8	5.36	5.36	5.35	5.4	6.03	6.02	6.02	6.0	5.36	5.36	5.35	5.4	6.03	6.02	6.02	6.0		
	Amps	12.07	12.06	12.03	12.2	13.90	13.88	13.85	14.0	15.94	15.92	15.89	16.0	18.14	18.13	18.10	18.2	20.60	20.59	20.56	20.7	23.50	23.48	23.45	23.6	20.60	20.59	20.56	20.7	23.50	23.48	23.45	23.6		
	Hi PR	263	264	266	270.2	304	305	307	311.8	348	349	351	355.3	395	396	398	402.2	445	446	448	452.7	499	500	502	506.7	445	446	448	452.7	499	500	502	506.7		
Lo PR	124	125	129	133.8	131	133	136	141.4	138	140	143	148.0	144	145	148	153.6	149	151	154	159.1	156	158	161	166.0	149	151	154	159.1	156	158	161	166.0			
80	MBh	61.2	62.0	63.8	66.5	60.6	61.5	63.3	66.0	59.1	59.9	61.7	64.4	56.4	57.2	59.0	61.7	53.1	53.9	55.7	58.4	50.1	50.9	52.7	55.4	53.1	53.9	55.7	58.4	50.1	50.9	52.7	55.4		
	S/T	1.00	0.82	0.69	0.6	1.00	0.83	0.70	0.6	1.00	0.85	0.72	0.6	1.00	1.00	0.74	0.6	1.00	1.00	0.76	0.6	1.00	1.00	0.81	0.7	1.00	1.00	0.76	0.6	1.00	1.00	0.81	0.7		
	ΔT	26.10	24.31	20.98	17.5	26.05	24.26	20.93	17.5	26.30	24.52	21.18	17.7	26.03	24.25	20.91	17.5	25.79	24.01	20.68	17.2	26.91	25.13	21.79	18.3	26.03	24.25	20.91	17.2	26.91	25.13	21.79	18.3		
	kW	3.44	3.43	3.43	3.5	3.86	3.85	3.85	3.9	4.33	4.32	4.31	4.3	4.83	4.83	4.82	4.9	5.40	5.40	5.39	5.4	6.06	6.06	6.05	6.1	5.40	5.40	5.39	5.4	6.06	6.06	6.05	6.1		
	Amps	12.24	12.22	12.19	12.3	14.06	14.05	14.02	14.2	16.10	16.09	16.06	16.2	18.31	18.29	18.26	18.4	20.77	20.76	20.72	20.9	23.66	23.65	23.61	23.8	20.77	20.76	20.72	20.9	23.66	23.65	23.61	23.8		
	Hi PR	266	267	269	273.9	308	309	311	315.5	351	353	354	359.0	398	399	401	405.9	449	450	452	456.5	503	504	506	510.4	449	450	452	456.5	503	504	506	510.4		
Lo PR	127	128	131	136.7	134	136	139	144.3	141	142	146	150.9	147	148	151	156.5	152	154	157	162.0	159	160	164	168.9	152	154	157	162.0	159	160	164	168.9			
2500	MBh	64.1	64.9	66.7	69.5	63.5	64.4	66.2	68.9	62.0	62.8	64.6	67.4	59.3	60.1	61.9	64.7	56.0	56.8	58.6	61.4	53.0	53.8	55.6	58.4	56.0	56.8	58.6	61.4	53.0	53.8	55.6	58.4		
	S/T	1.00	0.86	0.73	0.6	1.00	0.87	0.74	0.6	1.00	1.00	0.76	0.6	1.00	1.00	0.78	0.6	1.00	1.00	0.80	0.7	1.00	1.00	1.00	0.7	1.00	1.00	0.80	0.7	1.00	1.00	1.00	0.7		
	ΔT	23.90	22.12	18.79	15.3	23.86	22.07	18.74	15.3	24.11	22.32	18.99	15.5	23.84	22.05	18.72	15.3	23.60	21.81	18.48	15.0	24.72	22.93	19.60	16.1	23.60	21.81	18.48	15.0	24.72	22.93	19.60	16.1		
	kW	3.48	3.48	3.47	3.5	3.90	3.90	3.89	3.9	4.37	4.37	4.36	4.4	4.88	4.87	4.87	4.9	5.44	5.44	5.43	5.5	6.11	6.10	6.10	6.1	5.44	5.44	5.43	5.5	6.11	6.10	6.10	6.1		
	Amps	12.43	12.42	12.38	12.5	14.25	14.24	14.21	14.3	16.29	16.28	16.25	16.4	18.50	18.48	18.45	18.6	20.96	20.95	20.92	21.1	23.85	23.84	23.81	23.9	20.96	20.95	20.92	21.1	23.85	23.84	23.81	23.9		
	Hi PR	272	273	275	279.8	314	315	317	321.4	357	358	360	364.9	404	405	407	411.8	455	456	458	462.3	509	510	512	516.3	455	456	458	462.3	509	510	512	516.3		
Lo PR	133	134	137	142.7	140	142	145	150.3	147	148	152	156.9	153	154	157	162.5	158	160	163	168.0	165	166	170	174.9	158	160	163	168.0	165	166	170	174.9			
1500	MBh	61.0	61.8	63.6	66.3	60.4	61.3	63.1	65.8	58.9	59.7	61.5	64.2	56.2	57.0	58.8	61.5	52.9	53.7	55.5	58.2	49.9	50.7	52.5	55.2	52.9	53.7	55.5	58.2	49.9	50.7	52.5	55.2		
	S/T	1.00	0.81	0.68	0.5	1.00	0.82	0.69	0.5	1.00	1.00	0.71	0.6	1.00	1.00	0.73	0.6	1.00	1.00	0.75	0.6	1.00	1.00	1.00	0.7	1.00	1.00	0.75	0.6	1.00	1.00	1.00	0.7		
	ΔT	31.48	29.69	26.36	22.9	31.43	29.64	26.31	22.9	31.68	29.89	26.56	23.1	31.41	29.62	26.29	22.8	31.17	29.39	26.05	22.6	32.29	30.50	27.17	23.7	31.17	29.39	26.05	22.6	32.29	30.50	27.17	23.7		
	kW	3.41	3.40	3.40	3.4	3.83	3.82	3.82	3.8	4.30	4.29	4.28	4.3	4.80	4.80	4.79	4.8	5.37	5.37	5.36	5.4	6.03	6.03	6.02	6.1	5.37	5.37	5.36	5.4	6.03	6.03	6.02	6.1		
	Amps	12.11	12.09	12.06	12.2	13.93	13.92	13.89	14.0	15.97	15.96	15.93	16.1	18.18	18.16	18.13	18.3	20.64	20.63	20.59	20.7	23.53	23.52	23.48	23.6	20.64	20.63	20.59	20.7	23.53	23.52	23.48	23.6		
	Hi PR	264	265	267	271.4	305	307	308	313.0	349	350	352	356.5	396	397	399	403.4	446	448	449	454.0	500	501	503	507.9	446	448	449	454.0	500	501	503	507.9		
Lo PR	126	127	130	135.7	133	135	138	143.3	140	141	145	149.9	145	147	150	155.5	151	153	156	161.0	158	159	163	167.9	151	153	156	161.0	158	159	163	167.9			
85	MBh	62.2	63.0	64.8	67.6	61.6	62.5	64.3	67.0	60.1	60.9	62.7	65.4	57.4	58.2	60.0	62.8	54.1	54.9	56.7	59.5	51.1	51.9	53.7	56.4	54.1	54.9	56.7	59.5	51.1	51.9	53.7	56.4		
	S/T	1.00	0.92	0.79	0.7	1.00	1.00	0.80	0.7	1.00	1.00	0.82	0.7	1.00	1.00	0.84	0.7	1.00	1.00	0.80	0.7	1.00	1.00	1.00	0.8	1.00	1.00	0.80	0.7	1.00	1.00	1.00	0.8		
	ΔT	29.60	27.82	24.49	21.0	29.55	27.77	24.44	21.0	29.80	28.02	24.69	21.2	29.54	27.75	24.42	21.0	29.30	27.51	24.18	20.7	30.41	28.63	25.30	21.8	29.30	27.51	24.18	20.7	30.41	28.63	25.30	21.8		
	kW	3.44	3.44	3.43	3.5	3.86	3.86	3.85	3.9	4.33	4.33	4.32	4.4	4.84	4.84	4.83	4.9	5.41	5.40	5.40	5.4	6.07	6.07	6.06	6.1	5.41	5.40	5.40	5.4	6.07	6.07	6.06	6.1		
	Amps	12.27	12.26	12.23	12.4	14.10	14.08	14.05	14.2	16.14	16.12	16.09	16.2	18.34	18.33	18.30	18.4	20.80	20.79	20.76	20.9	23.69	23.68	23.65	23.8	20.80	20.79	20.76	20.9	23.69	23.68	23.65	23.8		
	Hi PR	268	269	271	275.2	309	310	312	316.7	353	354	356	360.3	400	401	403	407.1	450	451	453	457.7	504	505	507	511.6	450	451	453	457.7	504	505	507	511.6		
Lo PR	129	130	133	138.6	136	138	141	146.2	143	144	148	152.8	148	150	153	158.4	154	155	159	163.9	161	162	165	170.8	154	155	159	163.9	161	162	165	170.8			
2500	MBh	65.1	65.9	67.7	70.5	64.6	65.4	67.2	69.9	63.0	63.8	65.6	68.4	60.3	61.1	62.9	65.7	57.0	57.8	59.6	62.4	54.0	54.8	56.6	59.4	57.0	57.8	59.6	62.4	54.0	54.8	56.6	59.4		
	S/T	1.00	1.00	0.83	0.7	1.00	1.00	0.84	0.7	1.00	1.00	0.86	0.7	1.00	1.00	0.88	0.7	1.00	1.00	0.80	0.7	1.00	1.00	1.00	0.8	1.00	1.00	0.80	0.7	1.00	1.00	1.00	0.8		
	ΔT	27.41	25.62	22.29	18.8	27.36	25.57	22.24	18.8	27.61	25.83	22.49	19.0	27.34	25.56	22.22	18.8	27.10	25.32	21.99	18.5	28.22	26.44	23.10	19.7	27.10	25.32	21.99	18.5	28.22	26.44	23.10	19.7		
	kW	3.49	3.49	3.48	3.5	3.91	3.91	3.90	3.9	4.38	4.37	4.37	4.4	4.88	4.88	4.87	4.9	5.45																	

AIRFLOW DATA

GPGM52406031 - Rise Range: 25° - 55°												
E.S.P.	T1 LOW STAGE HEATING SPEED			T2 HIGH STAGE HEATING SPEED			T3 LOW STAGE COOLING SPEED		T4 HIGH STAGE COOLING SPEED		T5 COOLING SPEED	
	CFM	WATTS	RISE	CFM	WATTS	RISE	CFM	WATTS	CFM	WATTS	CFM	WATTS
0.1	700	76	48	1,080	197	42	744	72	1,021	149	1,090	197
0.2	665	84	51	1,032	204	44	696	79	976	157	1,055	201
0.3	614	91	55	988	212	46	646	86	932	164	1,020	207
0.4	561	98	60	948	220	47	591	93	885	171	995	212
0.5	505	105	67	902	225	50	524	99	844	178	955	230
0.6	438	114	77	859	231	52	466	106	795	185	915	240
0.7	374	119	90	813	238	55	405	111	744	192	880	255
0.8	318	125	106	770	245	58	356	116	683	199	835	246

GPGM53008031 - Rise Range: 35° - 65°												
E.S.P.	T1 LOW STAGE HEATING SPEED			T2 HIGH STAGE HEATING SPEED			T3 LOW STAGE COOLING SPEED		T4 HIGH STAGE COOLING SPEED		T5 COOLING SPEED	
	CFM	WATTS	RISE	CFM	WATTS	RISE	CFM	WATTS	CFM	WATTS	CFM	WATTS
0.1	1,035	156	43	1,300	287	46	848	89	1,171	201	1,295	289
0.2	990	165	45	1,265	293	47	797	96	1,127	208	1,260	294
0.3	950	173	47	1,220	310	49	740	104	1,087	217	1,220	304
0.4	910	184	49	1,190	306	50	680	112	1,043	224	1,180	313
0.5	865	190	52	1,145	319	52	615	120	990	231	1,140	319
0.6	820	200	55	1,105	320	54	551	126	941	239	1,105	326
0.7	765	204	59	1,070	330	56	462	132	885	245	1,055	334
0.8	725	211	62	1,015	338	59	384	138	826	251	1,015	337

GPGM53608031 - Rise Range: 35° - 65°												
E.S.P.	T1 LOW STAGE HEATING SPEED			T2 HIGH STAGE HEATING SPEED			T3 LOW STAGE COOLING SPEED		T4 HIGH STAGE COOLING SPEED		T5 COOLING SPEED	
	CFM	WATTS	RISE	CFM	WATTS	RISE	CFM	WATTS	CFM	WATTS	CFM	WATTS
0.1	950	115	47	1,245	230	48	960	134	1,450	396	1,440	354
0.2	895	124	50	1,195	238	50	897	142	1,400	405	1,390	365
0.3	840	134	54	1,150	247	52	828	148	1,349	413	1,355	369
0.4	775	146	58	1,095	256	55	766	156	1,302	420	1,300	383
0.5	710	152	63	1,045	263	57	695	163	1,253	428	1,260	396
0.6	650	160	X	990	277	61	634	168	1,203	436	1,210	402
0.7	590	163	X	935	285	64	571	173	1,152	442	1,160	397
0.8	540	171	X	870	288	X	509	178	1,102	449	1,110	415

GPGM54210031 - Rise Range: 35° - 65°												
E.S.P.	T1 LOW STAGE HEATING SPEED			T2 HIGH STAGE HEATING SPEED			T3 LOW STAGE COOLING SPEED		T4 HIGH STAGE COOLING SPEED		T5 COOLING SPEED	
	CFM	WATTS	RISE	CFM	WATTS	RISE	CFM	WATTS	CFM	WATTS	CFM	WATTS
0.1	1,100	172	51	1,420	325	53	1,210	220	1,571	430	1,620	484
0.2	1,040	181	54	1,360	331	55	1,140	226	1,520	439	1,575	489
0.3	985	185	57	1,310	342	57	1,085	235	1,472	448	1,530	497
0.4	920	193	61	1,275	353	59	1,023	243	1,403	454	1,490	500
0.5	875	203	64	1,210	360	62	963	250	1,356	463	1,450	507
0.6	815	207	X	1,165	368	64	901	259	1,302	470	1,405	518
0.7	765	215	X	1,115	369	X	846	266	1,247	476	1,345	516
0.8	710	216	X	1,075	385	X	786	271	1,188	480	1,300	528

GPGM54810031 - Rise Range: 35° - 65°												
E.S.P.	T1 LOW STAGE HEATING SPEED			T2 HIGH STAGE HEATING SPEED			T3 LOW STAGE COOLING SPEED		T4 HIGH STAGE COOLING SPEED		T5 COOLING SPEED	
	CFM	WATTS	RISE	CFM	WATTS	RISE	CFM	WATTS	CFM	WATTS	CFM	WATTS
0.1	1,085	171	52	1,410	326	53	1,326	287	1,601	733	1,790	641
0.2	1,035	178	54	1,365	329	55	1,273	294	1,544	744	1,745	650
0.3	985	184	57	1,315	337	57	1,222	303	1,485	751	1,710	659
0.4	925	193	61	1,270	353	59	1,172	311	1,435	760	1,670	663
0.5	870	198	65	1,220	360	61	1,123	319	1,383	766	1,625	674
0.6	815	208	X	1,175	372	64	1,073	328	1,333	779	1,585	672
0.7	760	213	X	1,115	375	X	1,027	337	1,279	787	1,540	675
0.8	710	219	X	1,080	381	X	978	344	1,219	792	1,495	683

5 Ton Models: GPGM56014031

DOWN FLOW						
SPEED TAP	TORQUE %	TORQUE OZ-FT	EXTERNAL STATIC PRESSURE (ESP), IN W.C.	SCFM	RPM	BHP
T1*	0.2	1135	620	0.16	570	0.14
			0.4	1000	775	0.19
			0.6	865	780	0.2
			0.8	750	845	0.23
T2**	0.2	1910	870	0.63	640	0.20
			0.4	1825	925	0.67
			0.6	1735	970	0.7
			0.8	1655	1020	0.74
T3	0.2	1910	870	0.63	883	0.66
			0.4	1825	925	0.67
			0.6	1735	970	0.7
			0.8	1655	1020	0.74
T4	0.2	1895	865	0.62	883	0.66
			0.4	1810	920	0.66
			0.6	1720	965	0.69
			0.8	1640	1020	0.73
T5	0.2	2145	955	0.91	2196	2.09
			0.4	2065	990	0.94
			0.6	1980	1035	0.99
			0.8	1900	1075	1.02

HORIZONTAL FLOW						
SPEED TAP	TORQUE %	TORQUE OZ-FT	EXTERNAL STATIC PRESSURE (ESP), IN W.C.	SCFM	RPM	BHP
T1*	0.2	1190	605	0.16	606	0.14
			0.4	1055	685	0.18
			0.6	915	755	0.21
			0.8	790	820	0.22
T2**	0.2	2005	845	0.61	617	0.19
			0.4	1915	895	0.65
			0.6	1820	940	0.68
			0.8	1740	990	0.72
T3	0.2	2005	845	0.61	853	0.63
			0.4	1915	895	0.65
			0.6	11820	940	0.68
			0.8	1740	990	0.72
T4	0.2	1990	840	0.6	853	0.63
			0.4	1900	890	0.64
			0.6	1805	935	0.67
			0.8	1720	990	0.71
T5	0.2	2250	925	0.88	929	0.88
			0.4	2170	960	0.91
			0.6	2080	1005	0.96
			0.8	1995	1045	0.99

* - T1 Values Are For Fan Mode Or Part Load Only

** - T2 Values Are For Part Load Only

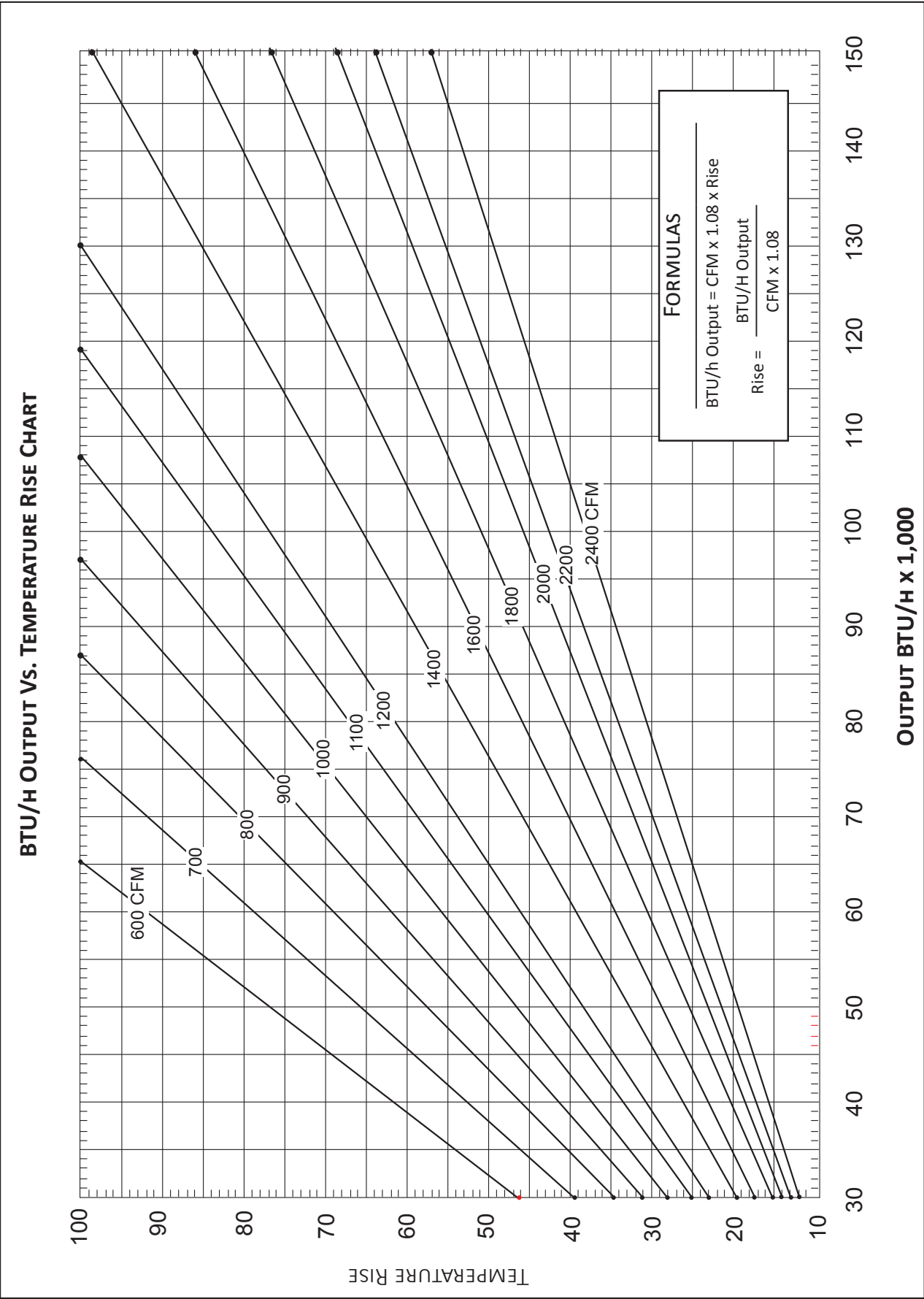

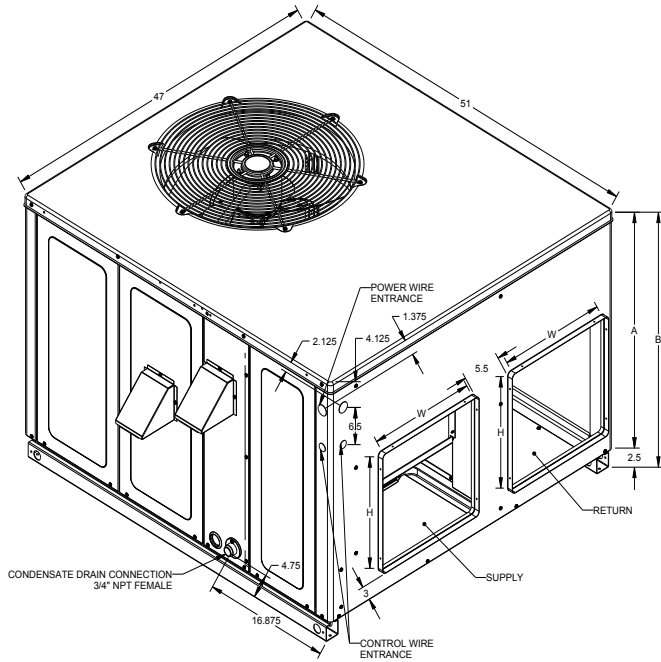

MODEL	UNIT DIMENSIONS (INCHES)				CHASSIS SIZE
			HEIGHT		
	W	D	A	B	
GP*M524***31	47	51	32	34½	Medium
GP*M530***31	47	51	32	34½	Medium
GP*M536***31	47	51	40	42½	Large
GP*M542***31	47	51	40	42½	Large
GP*M548***31	47	51	40	42½	Large
GP*M560***31	73 3/8	47 5/8	40	42½	X-Large

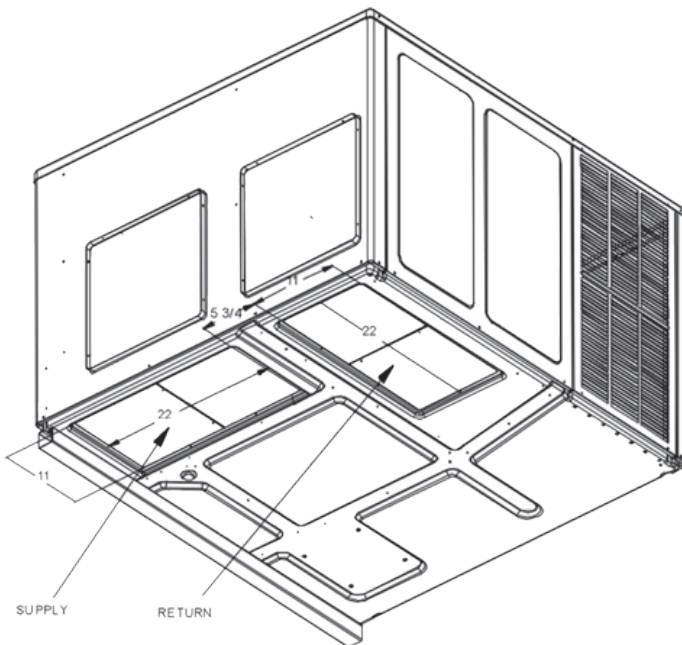

MODEL	DUCT OPENINGS			
	SUPPLY		RETURN	
	W	H	W	H
GP*M524***31	16	16	16	16
GP*M530***31	16	16	16	16
GP*M536***31	16	18	16	18
GP*M542***31	16	18	16	18
GP*M548***31	16	18	16	18
GP*M560***31	17	12	11	25

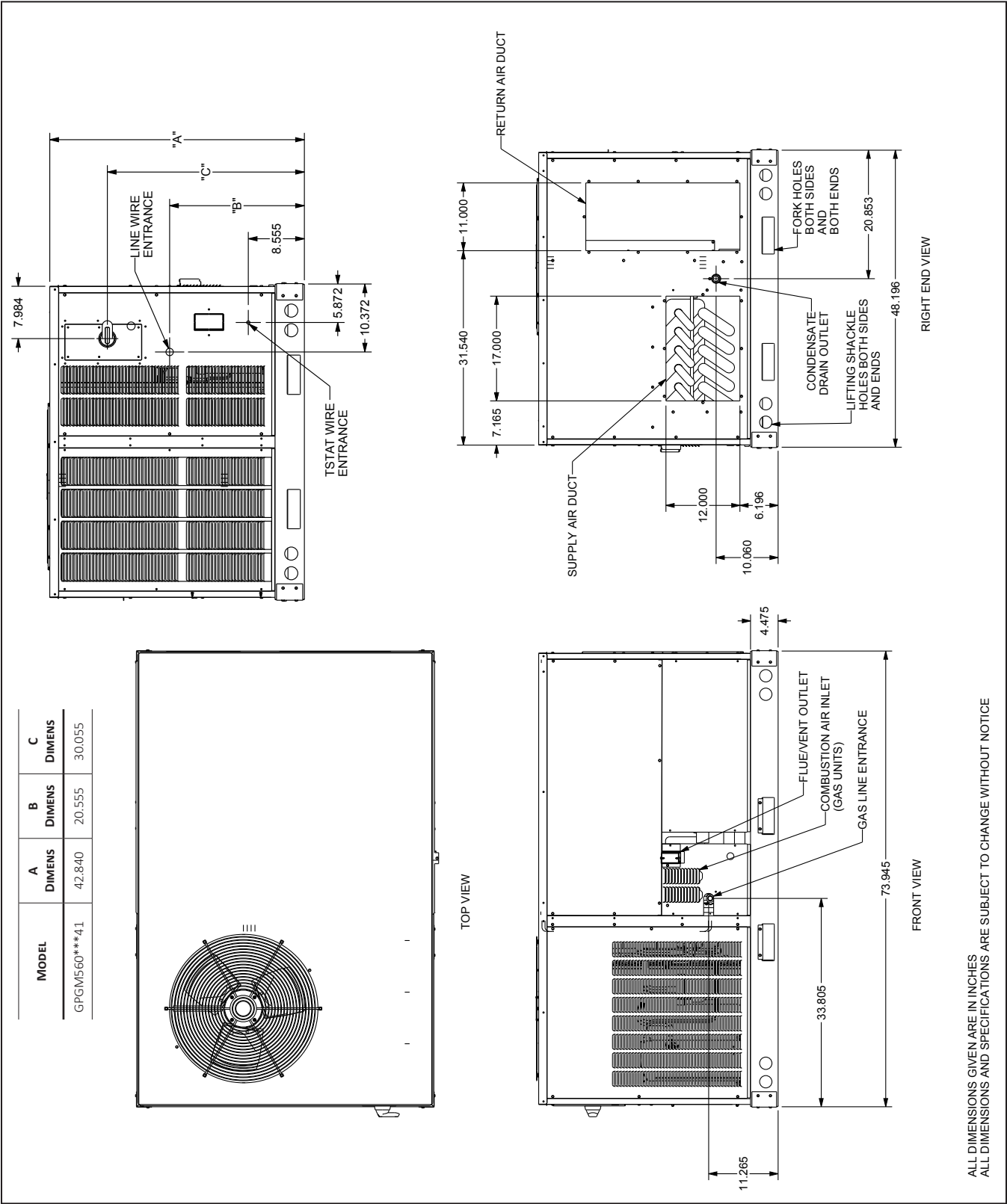

MODEL	A DIMENS	B DIMENS	C DIMENS
GPGM560***41	42.840	20.555	30.055

ALL DIMENSIONS GIVEN ARE IN INCHES
 ALL DIMENSIONS AND SPECIFICATIONS ARE SUBJECT TO CHANGE WITHOUT NOTICE

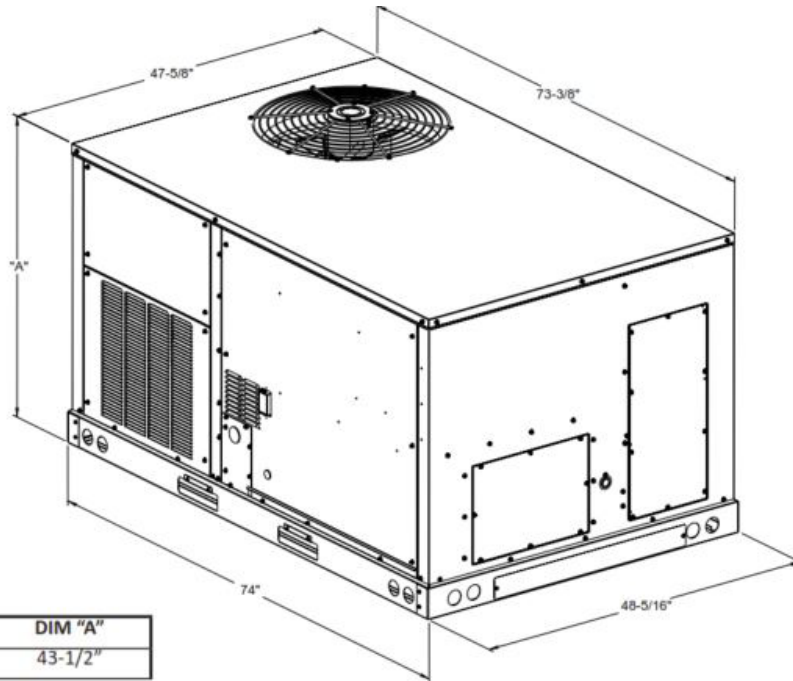

Model size	DIM "A"
5 ton	43-1/2"

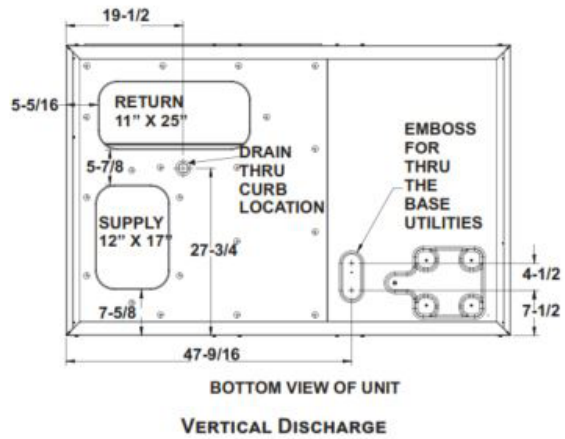
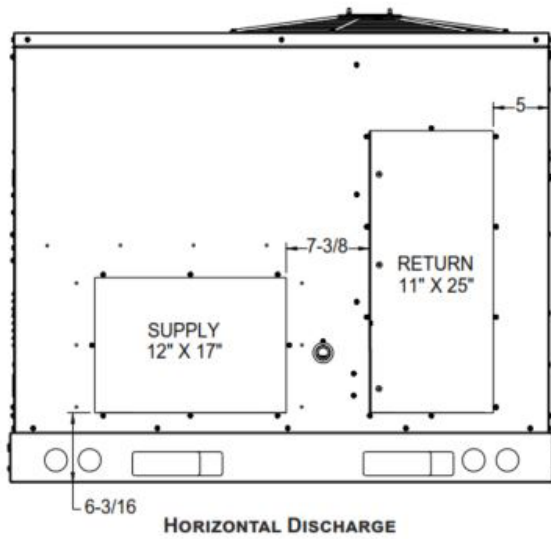

NOTE: REFER TO IOD-7082 INCLUDED IN THE LITERATURE PACK FOR INSTALLING HORIZONTAL DUCT COVERS.

Provisions for forks have been included in the unit base frame. No other fork locations are approved.

- Unit must be lifted by the four lifting holes located at the base frame corners.
- Lifting cables should be attached to the unit with shackles.
- The distance between the crane hook and the top of the unit must not be less than 60".
- Two spreader bars must span over the unit to prevent damage to the cabinet by the lift cables. Spreader bars must be of sufficient length so that cables do not come in contact with the unit during transport. Remove wood struts mounted beneath unit base frame before setting unit on roof curb. These struts are intended to protect unit base frame from fork lift damage. To remove the struts, extract the sheet metal retainers and pull the struts through the base of the unit. Refer to rigging label on the unit.

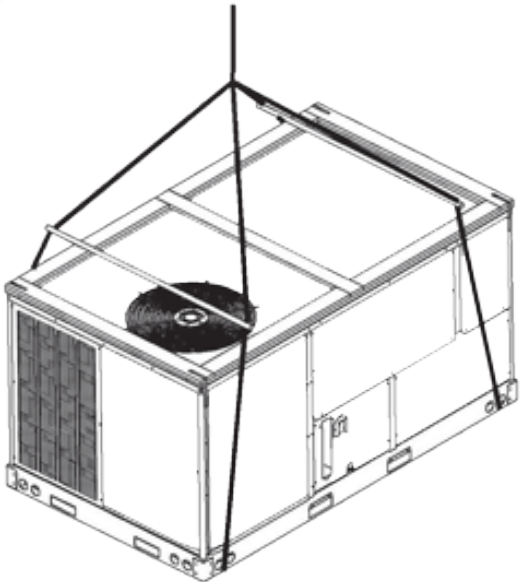

Important: If using bottom discharge with roof curb, duct-work should be attached to the curb prior to installing the unit. Duct-work dimensions are shown in Roof Curb Installation Instructions Manual.

Refer to the Roof Curb Installation Instructions for proper curb installation. Curbing must be installed in compliance with the National Roofing Contractors Association Manual.

Lower unit carefully onto roof mounting curb. While rigging the unit, the center of gravity will cause the condenser end to be lower than the supply air end.

Bring condenser end of unit into alignment with the curb. With condenser end of the unit resting on curb member and using curb as a fulcrum, lower opposite end of the unit until entire unit is seated on the curb. When a rectangular cantilever curb is used, take care to center the unit. Check for proper alignment and orientation of supply and return openings with duct.

To assist in determining rigging requirements, unit weights are shown on the following page.

Curb installations must comply with local codes and should follow the established guidelines of the National Roofing Contractors Association.

Proper unit installation requires that the roof curb be firmly and permanently attached to the roof structure. Check for adequate fastening method prior to setting the unit on the curb.

Full perimeter roof curbs are available from the factory and are shipped unassembled. The installing contractor is responsible for field assembly, squaring, leveling, and mounting on the roof structure. All required hardware necessary for the assembly of the sheet metal curb is included in the curb accessory package.

- Determine sufficient structural support before locating and mounting the curb and package unit.
- Duct-work must be constructed using industry guidelines. The duct-work must be placed into the roof curb before mounting the package unit. Our full perimeter curbs include duct connection frames to be assembled with the curb. Cantilevered-type curbs are not available from the factory.
- Contractor furnishes curb insulation, cant strips, flashing, and general roofing material.
- Support curbs on parallel sides with roof members. To prevent damage to the unit, the roof members cannot penetrate supply and return duct openings.

Note: The unit and curb accessories are designed to allow vertical duct installation before unit placement. Duct installation after unit placement is not recommended.

See the manual shipped with the roof curb for assembly and installation instructions.

3-D VIEW

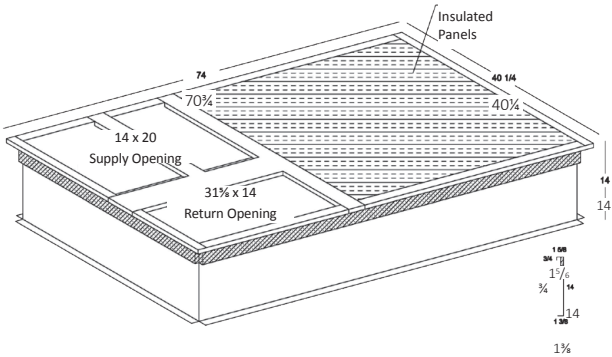

TOP VIEW

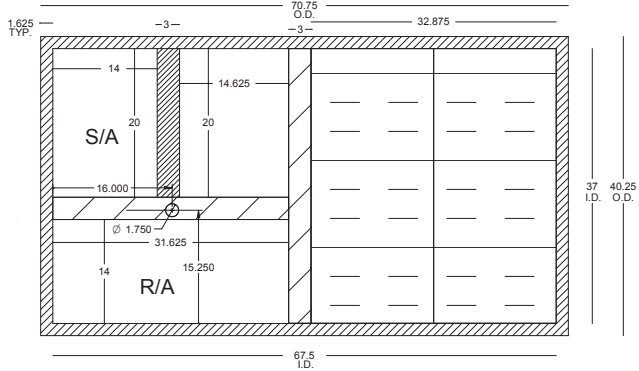

CORNER & CENTER-OF-GRAVITY LOCATIONS

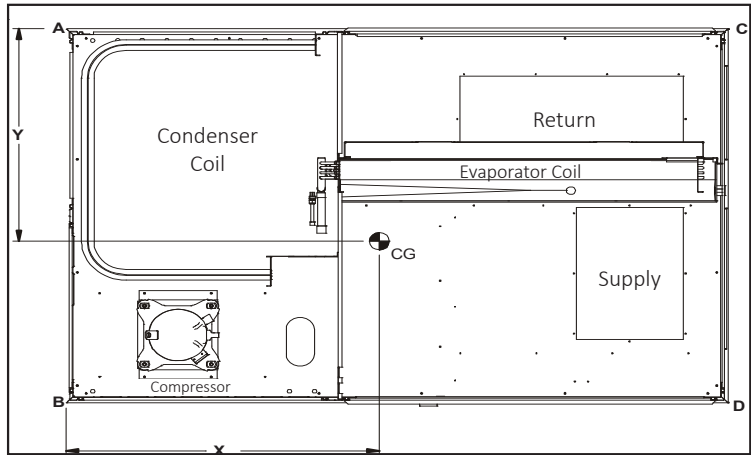

MODEL	X (IN)	Y (IN)	SHIPPING WEIGHT (LBS)	OPERATING WEIGHT (LBS)	CORNER WEIGHTS (LBS.)			
					A	B	C	D
GPGM560***31**	46.4	28.1	655	629	186	204	65	174

UNIT CLEARANCES

Maintain an adequate clearance around the unit for safety, service, maintenance, and proper unit operation. Leave a total clearance of 75" on the main control panel side of the unit for possible removal of fan shaft, coil, electric heat, and gas furnace. Leave a clearance of 48" on all other sides of the unit for possible compressor removal or service access, and to ensure proper ventilation and condenser airflow. Do not install the unit beneath any obstruction. Install the unit away from all building exhausts to inhibit ingestion of exhaust air into the unit's fresh-air intake.

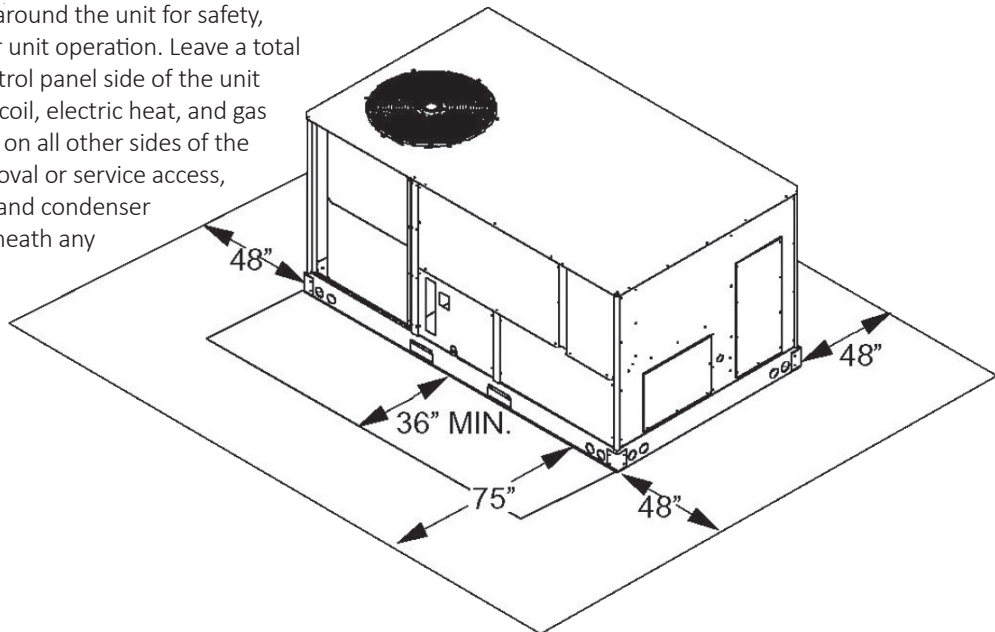

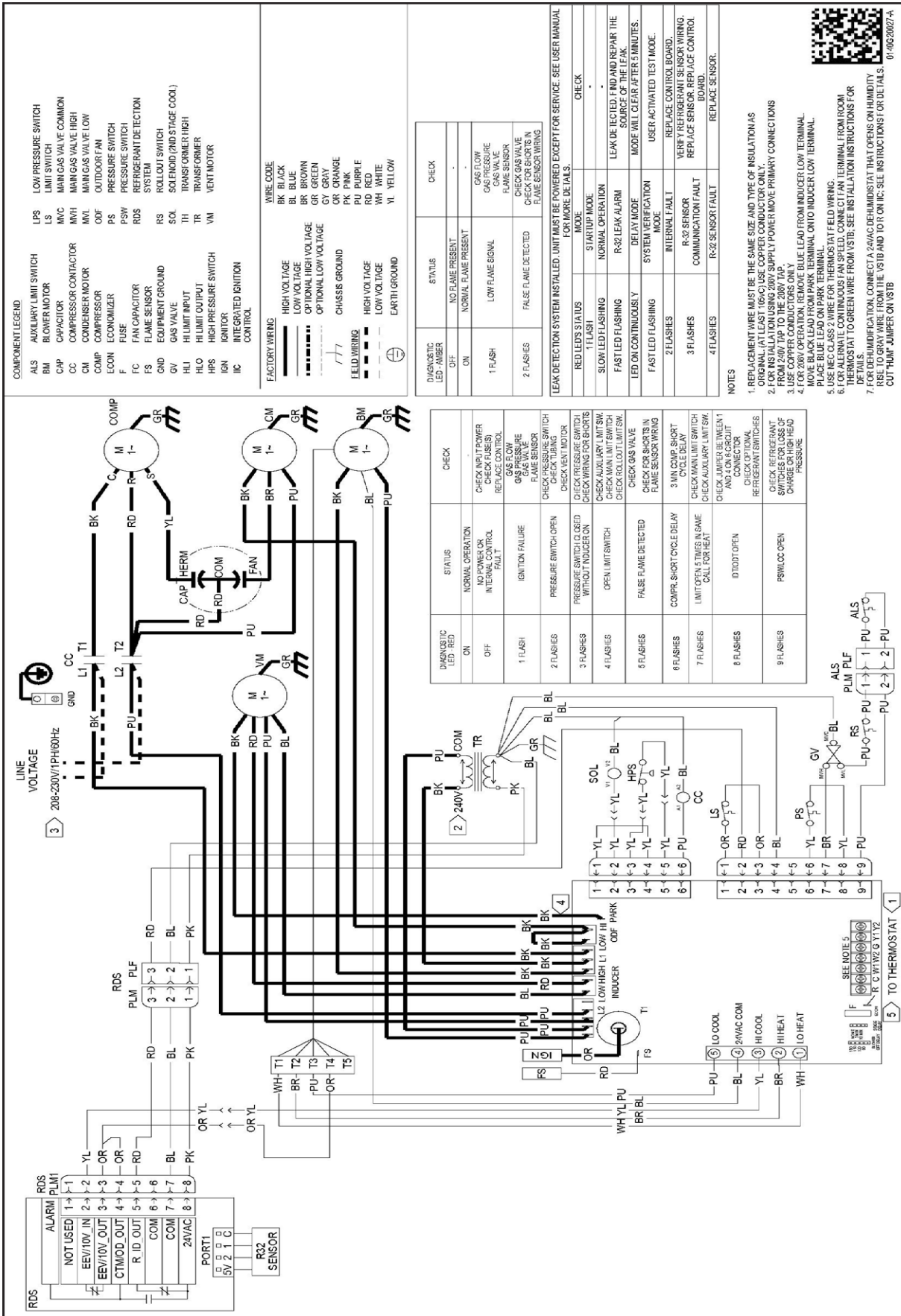

WARNING

High Voltage: Disconnect all power before servicing or installing this unit. Multiple power sources may be present. Failure to do so may cause property damage, personal injury, or death.

Wiring is subject to change. Always refer to the wiring diagram or the unit for the most up-to-date wiring.

FOR GPGM524-48*31 UNITS**

ACCESSORY DESCRIPTION	ITEM NUMBER	
	MEDIUM CHASSIS	LARGE CHASSIS
Concentric Kit	CDK36	CDK4872
Downflow Economizer	PGEDJ101/102	PGEDJ103
Downflow Internal Filter Rack (with economizer)	DDNIFRPGMM	N/A (built into economizer)
Downflow Internal Filter Rack (no economizer)	DDNIFRPGA	DDNIFRPGA
Downflow Manual Damper	PGMDD101/102	PGMDD103
Downflow Motorized Damper	PGMDMD101/102	PGMDMD103
Downflow Square to Round	SQRPG101/102	SQRPG103
Economizer Wiring Harness (2-4 Tons)	0259G00214	0259G00214
Economizer Wiring Harness (5 Tons)	N/A	0259L00412
External Horizontal Filter Rack	DPHFRA	DPHFRA
High-Altitude Kit	HA-03	HA-03
Horizontal Duct Cover	20464501PDGK	20464502PDGK
Horizontal Economizer	DHZECNJPGCHM	DHZECNJPGCHL
Horizontal Manual Damper	PGMDH102	PGMDH103
Horizontal Motorized Damper	PGMDMH102	PGMDMH103
Horizontal Square to Round	SQRPGH101/102	SQRPGH103
Internal Horizontal Filter Rack	DHZIFRPGCHA	DHZIFRPGCHA
LP Conversion Kit (Single-Stage Models)	LPM-07	LPM-07
LP Conversion Kit (Two-Stage Models)	N/A	LPM-08
Outdoor Thermostat with Housing	OTDFPKG-01	OTDFPKG-01
Roof Curb	D14CRBPGCHMA	D14CRBPGCHMA

For GPGM560*31 UNITS**

ITEM #	DESCRIPTION
0221L00014	14" Roof Curb
0270L01166	25% Manual Fresh Air Damper
0270L01165	25% Motorized Fresh Air Damper
0270L01338	Concentric Duct Adapter Kit 18"
0270L01753	Downflow Low-Leak Economizer Enthalpy
0270L01755	Downflow Ultra Low-Leak Economizer Enthalpy
0270L01757	Horizontal Ultra Low-Leak Economizer Enthalpy
0270L01250	Hurricane Restraint Clips (for 0221L00014 Roof Curb)
0270L01261	Hurricane Restraint Clips
HAKT036150	High Altitude Kit
LPHE-036072	LP Conversion Kit
HEFLUE048060	Flue Extension Kit

