

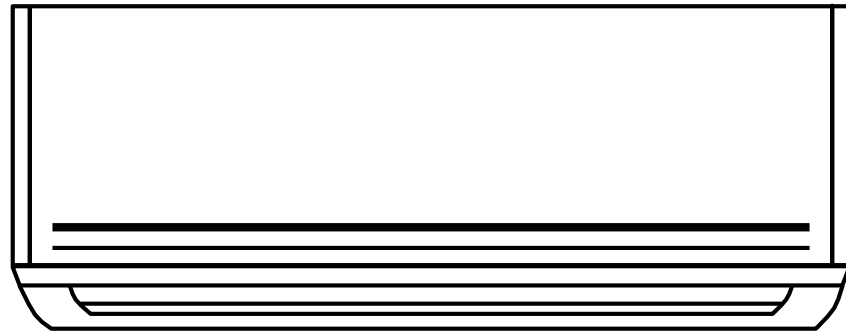

# S4 Quick Install Guide Wall Mount Air Handlers

Series 4 Single Zone Ductless Mini-Split for Heating & Cooling



## MODELS

- BMV6HH27
- BMHH09Y25
- BMV9HH28
- BMV12HH26
- BMV18HH22
- BMV24HH22
- BMV33HH20

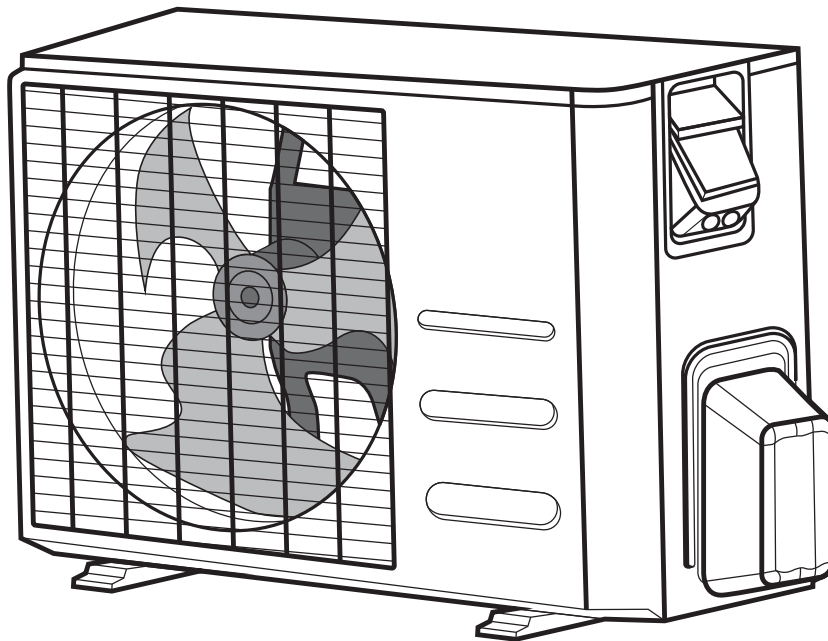

# PREP FOR INSTALL

## 1

Your indoor air handler has been pre-pressurized with nitrogen.

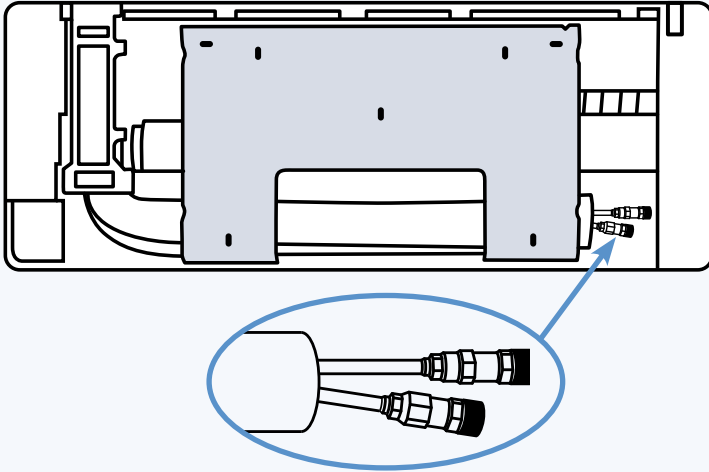

- On the back of the unit, loosen the cap on either of the 2 insulated copper tubes.
- You should hear a hissing noise, which is the release of this harmless gas.
- Allow all of the nitrogen to escape the line, re-tighten the cap, and repeat this process for the other copper tube.

If you don't hear a hissing noise when loosening the cap, please call us at 800.865.5931.

## 2

Choose the place for the indoor unit on an exterior (outermost) wall.

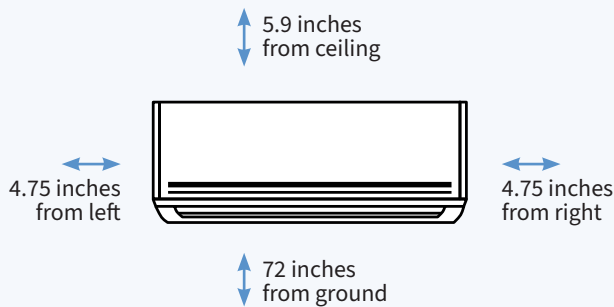

! Maintain listed clearances

If you select not to install the air handler on an exterior wall, please see full Owner & Install manual.

## 3

Choose the location to place the outdoor unit.

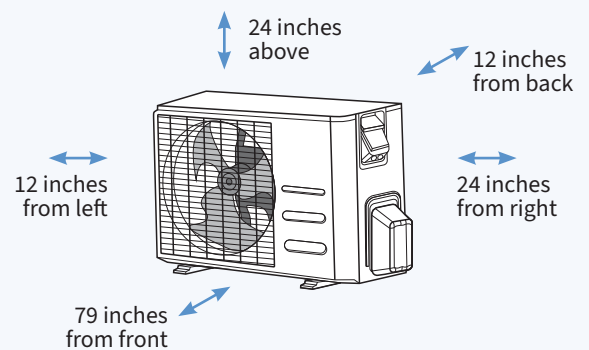

! Maintain listed clearances

# INDOOR UNIT

4

Remove the mounting bracket from the back of the indoor unit and mount it to the wall using the included hardware.

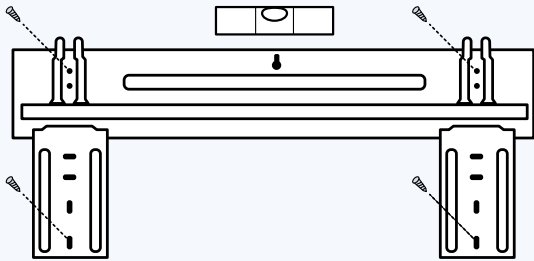

! Bracket must be horizontally level.

5

Mark the position of the large hole for the connecting line set and wires.



By default, the line set will exit the indoor unit on the right side (facing the unit).

If you wish to alter the configuration of the line set, please see full Owner & Install manual.

6

Drill hole through the wall, maintaining a slight pitch downwards to aid outside drainage.

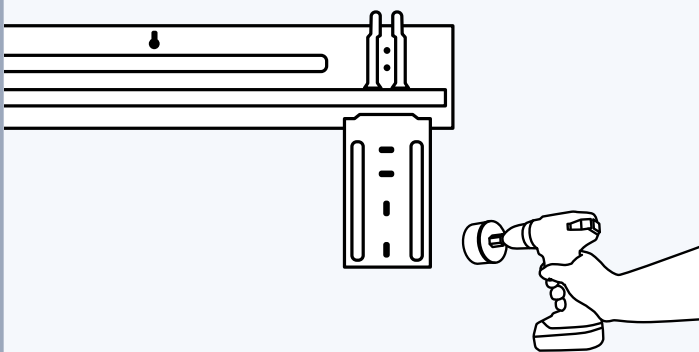

! Hole must be free of electrical wiring, plumbing, or other obstructions.

7

Insert wall sleeve through the wall with the flange facing the exterior.

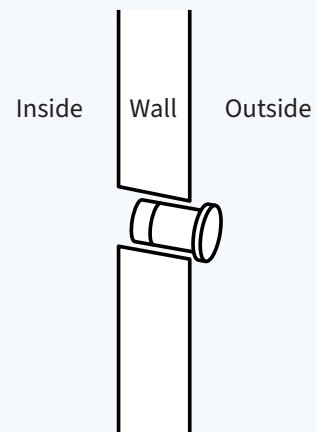

If you can't maintain a downwards pitch, you must install a condensate pump.

# INDOOR UNIT

8

Remove wire cover on front of indoor unit.

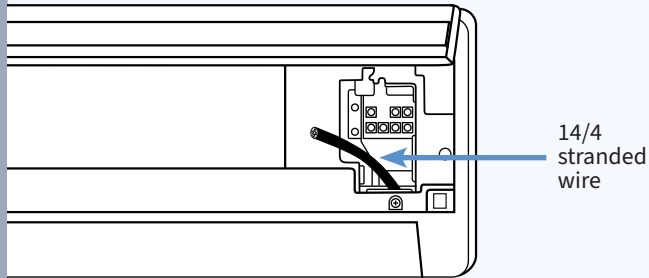

Feed 14/4 stranded wire from the back of the unit to the front.

9

Connect wires to indoor unit.

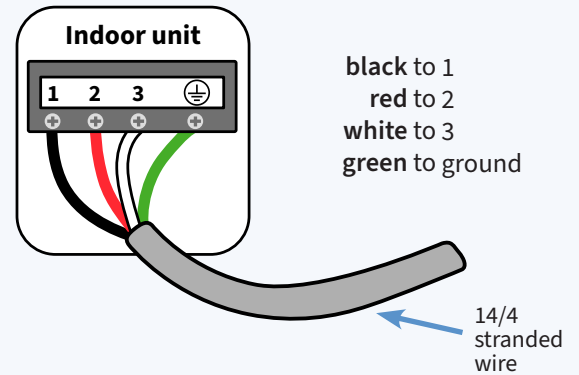

10

Attach the drain hose and prepare the connecting line set, drain, and wires.

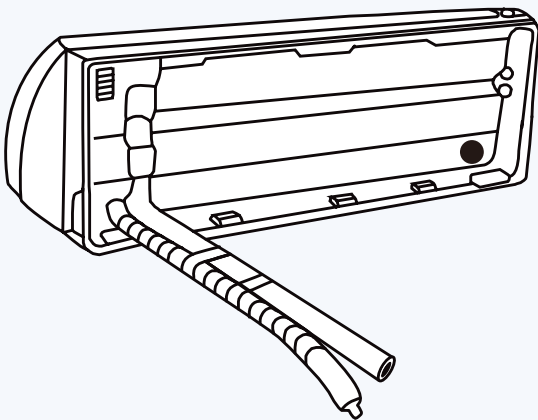

For most installations, the line set will be bent 90° to exit through the wall (as shown above).

11

Bundle the line set, drain, and connection wires together, keeping drain line on bottom.

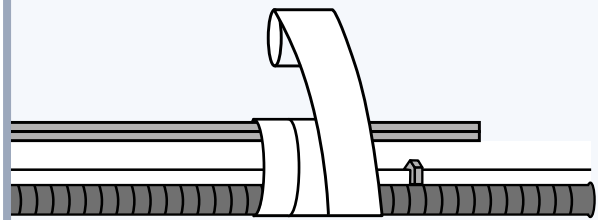

Use PVC electrical tape to secure every 3-4 feet, then install zip ties over taped sections.

! Do not overtighten tape and zip ties, as that will crimp the line set.

The minimum line set is 10 feet. If that length is longer than needed, reposition the outdoor unit or horizontally coil the refrigerant lines after connection.

## INDOOR UNIT

# 12

**Hang the indoor unit on the mounting bracket.**

Feed the bundled connection lines through the hole to the outside.

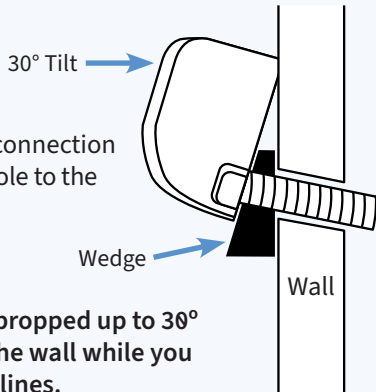

**!** Unit can be propped up to 30° away from the wall while you manage the lines.

# 13

**Bend the line set on the exterior of the wall towards the outdoor unit.**

Run the drain tubing to the ground, at least 12 inches from the structure.

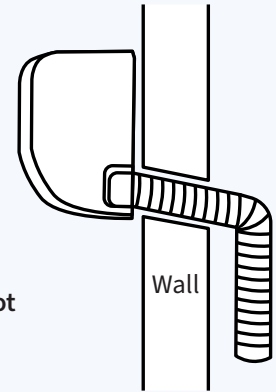

**!** When bending, do not kink the line set.

With lines larger than 3/8 inch OD, use of a tubing bender is recommended.

## OUTDOOR UNIT

# 14

**Mount on a pad, bracket, or stand.**

**!** Position the outdoor unit so it is blowing away from the structure.

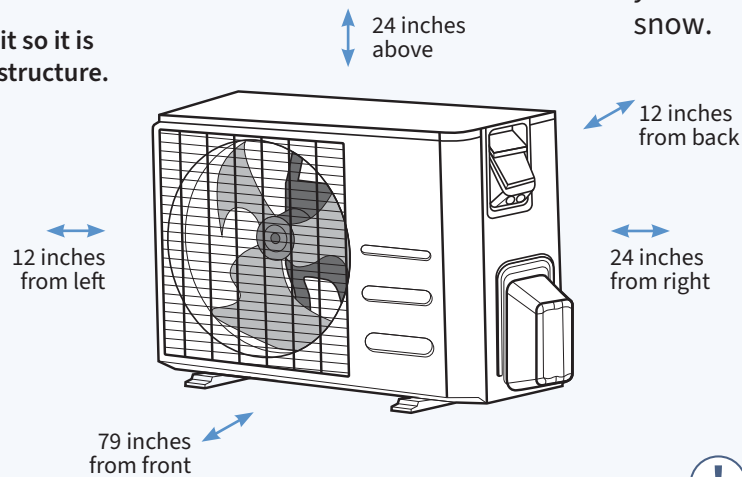

It is highly recommended to install the outdoor unit on a stand or bracket. Especially if you live in an area that can get snow.

**!** Maintain listed clearances

- Any high voltage electrical installation should be performed by an electrician or contractor.
- Make sure the electricity is off.
- Follow all local and national electrical codes.
- Always verify line and load lug locations on the disconnect prior to wiring.
- Wiring shown is based on load, line, line, load.

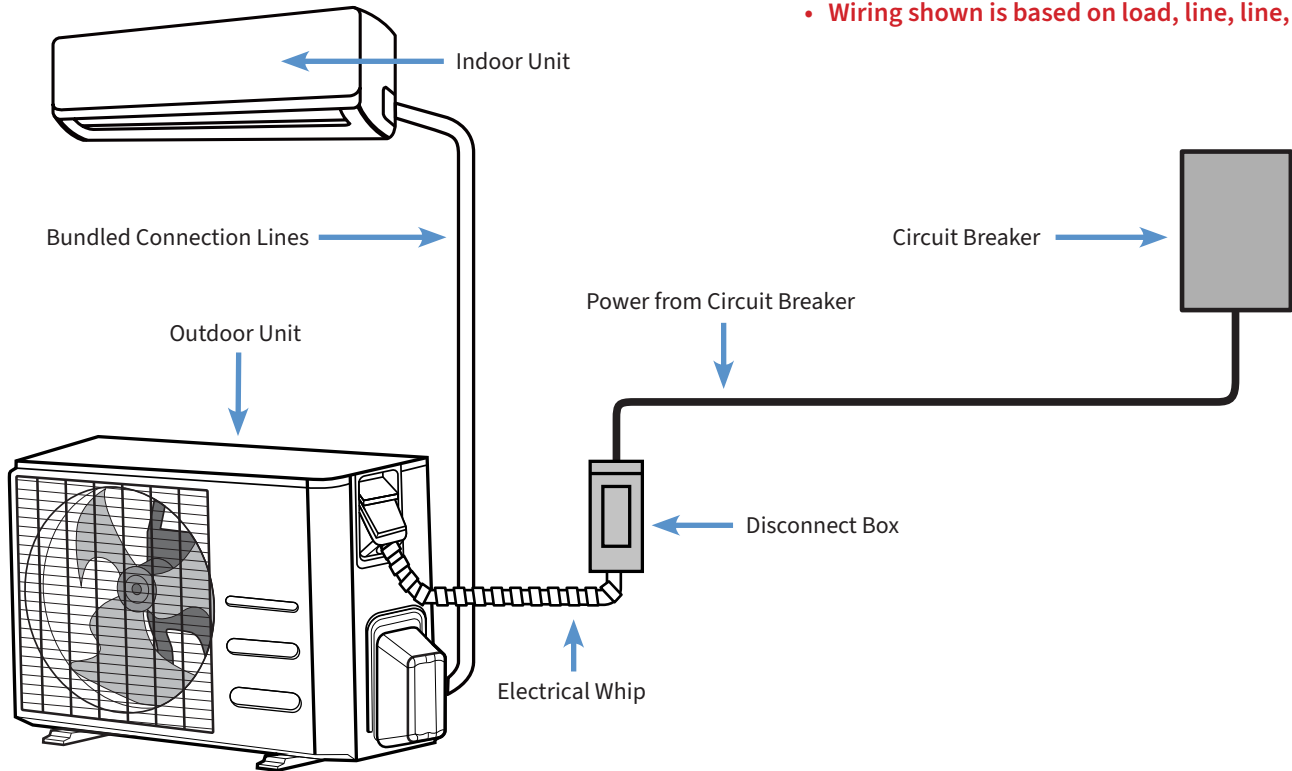

## 15

**Using correct size breaker and wire, run the power to the disconnect box mounted beside the outside unit.**

- Connect the indoor unit to the outdoor unit.
- Connect the outdoor unit to the disconnect box with the electrical whip.

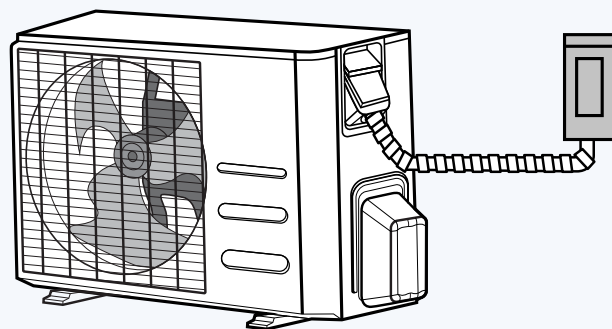

! See next page for wiring diagrams

## FOR 208/240 VOLT SYSTEM

### 16

Connect indoor unit to the outdoor unit.

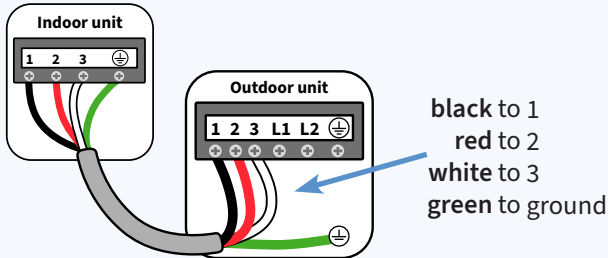

**!** Wiring shown is based on load, line, line, load.

### 17

Connect outdoor unit to disconnect box.

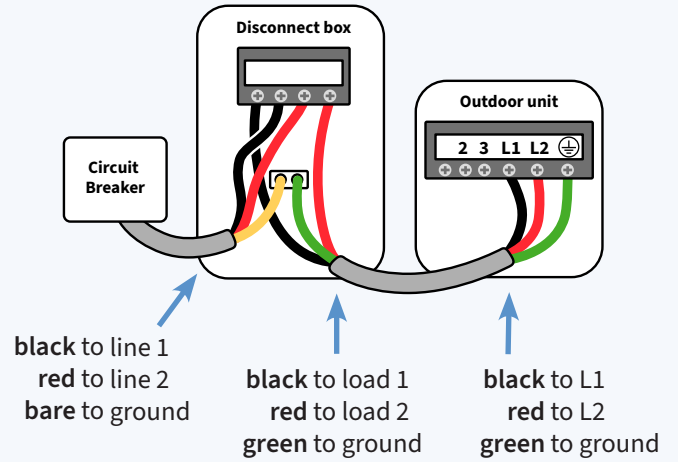

## FOR 110/120 VOLT SYSTEM

### 18

Connect indoor unit to the outdoor unit.

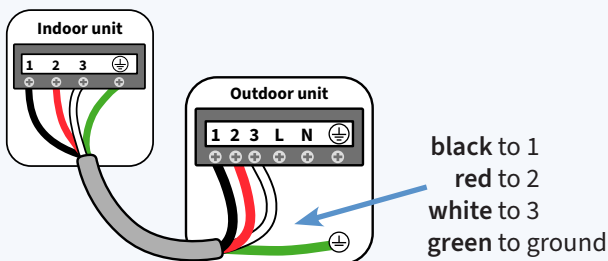

### 19

Connect outdoor unit to disconnect box.

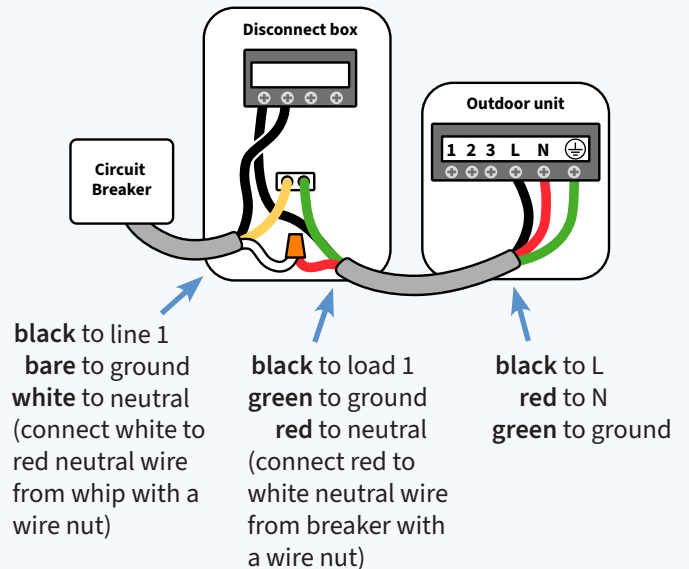

## REFRIGERANT | INDOOR UNIT

### 20

**Remove caps from the line set connections on air handler.**

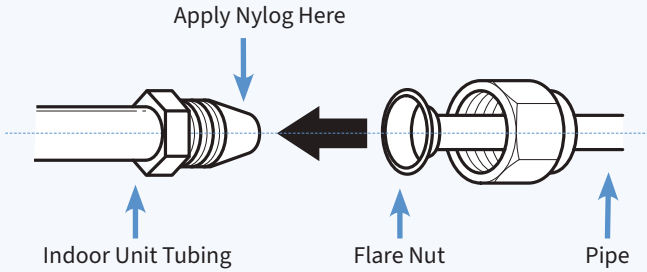

Apply a couple of drops of Nylog sealant to the male side of the flare connection.



**Warning: Refrigerant handling should be done by a trained professional.**

### 21

**Connect the additional length of line set to the line set on the back of the indoor unit.**

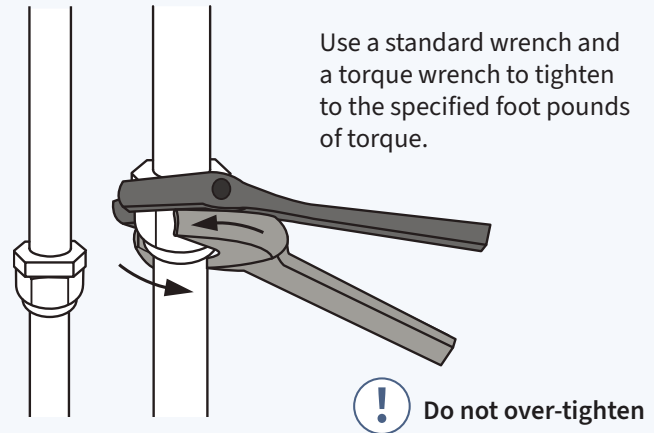

## REFRIGERANT | OUTDOOR UNIT

### 22

**Remove caps from the outdoor unit.**

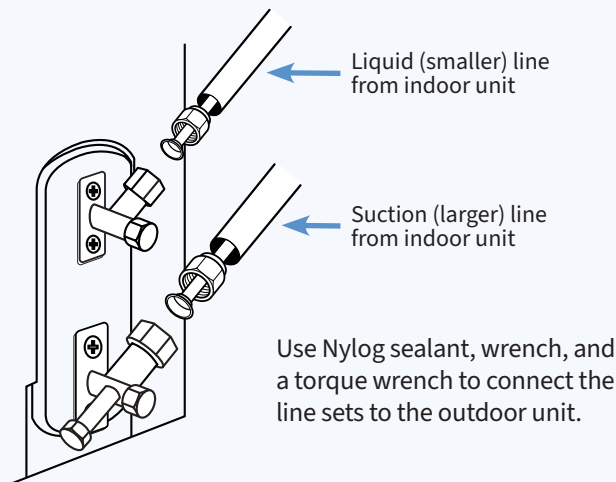

### 23

**Remove cap from the service port on the suction line and perform a pressure test to 300 - 350 psi from the outdoor unit.**

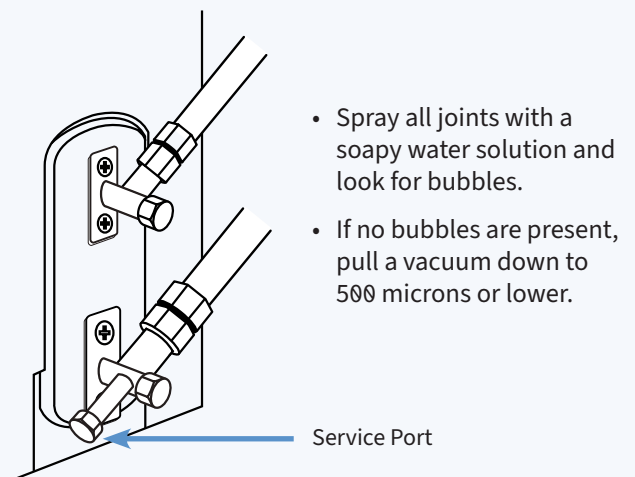

**Warning:** Refrigerant handling should be done by a trained professional.

## 24

After creating the vacuum, close the valves to the vacuum pump.

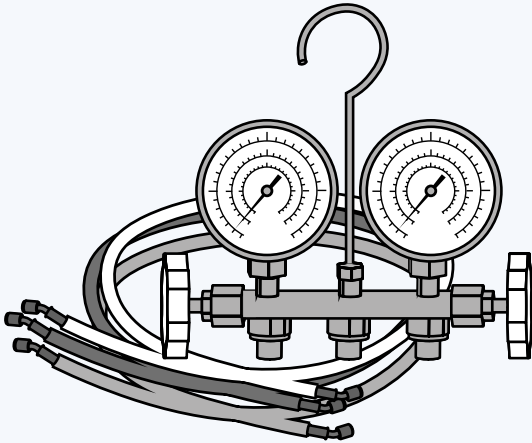

Add refrigerant if the line set used is more than 25 feet in length.

- Add 0.16 oz per foot past 25 if using ¼ inch OD liquid lines (In 0.75, 1.0, and 1.5 ton models)
- Add 0.32 oz per foot past 25 if using ⅜ inch OD liquid lines (In 2.0 ton models)

## 25

Open horizontal facing valve caps.

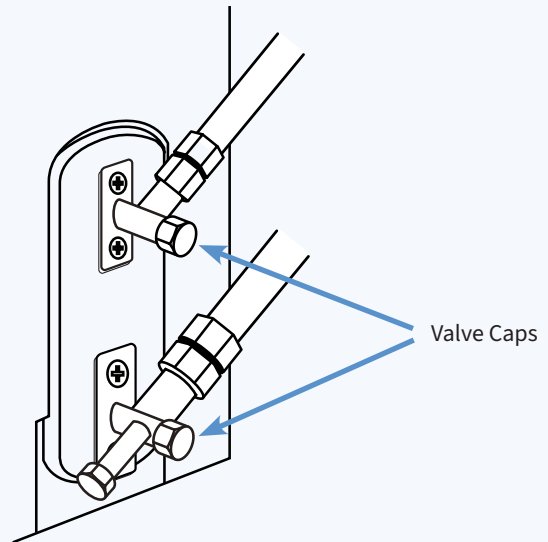

- Use a 5mm allen wrench (hex key) to fully open the lower and then upper valve, releasing the refrigerant into the system.
- Replace caps over open valves.

## 26

Power up and start the system.

Please call 1.800.865.5931 if you have any questions prior to or during the installation process of your Blueridge Mini-Split System.

Because of the Blueridge promise for continuous product innovation and improvement, some specifications and instructions may change without notification.