



# SpeediChannel™

System Installation



# Contents

## ***Introduction***

- 3 DiversiTech Speedichannel™ System
- 4 Features and Benefits

## ***System Installation***

- 6 Step 1
- 7 Step 2
- 8 Step 3
- 9 Step 4
- 10 Step 5
- 11 Step 6

## ***Installation Diagrams***

- 12 Indoor and Outdoor installations
- 14 Flex Joint and Drain Hose diagrams
- 16 Line Set configuration
- 17 Air Handler installations

## ***Sizing Chart***

- 21 Dimensions and Capacities

## ***Technical Information***

- 22 General data and safety information

## ***Mini Component Guide***

- 23 Product information and product layout

## DiversiTech SpeediChannel™ System

DiversiTech SpeediChannel™ is an innovative channel system used to cover air conditioning line sets. The two part system has a base and a cover. The base is fastened to a wall or ceiling, then a clever little plastic clip (**SpeediClip™**) snaps into a channel already molded into the base. SpeediClip™ is the fastest, most convenient way to complete a line set cover installation. Then, using standard cable ties, the line set, cables, control wires, and/or condensate drain line are fastened in place. The cover then simply snaps on top of the base.

The SpeediChannel™ system is available in three widths – 3", 4", and 6". Each piece of SpeediChannel™ is 6-1/2 feet long. A complete line of couplings, elbows, and tees are available for the SpeediChannel™ system.

Manufactured from rigid PVC, the SpeediChannel™ system is a natural color that is a very close match to the typical mini split condensing unit case. However, the SpeediChannel™ system can be painted as desired to match any wall color. The PVC used in the SpeediChannel™ system is resistant to UV light, and is UL rated.



DiversiTech recommends attaching the base to the wall or ceiling and the line sets to the system every 15" to allow for the system to carry the full weight of the line sets.

The SpeediChannel™ system can also be used inside.

## Features and Benefits

- SpeediClip™
  - SpeediClip™ simply slides into place on a railing molded into the inside of the SpeediChannel™ allowing for single person installation. Competitive products must be screwed in place which is extremely time consuming.
- Paintable
  - The SpeediChannel™ can be easily customized to any wall construction. \*See painting specifications below.
- Natural color
  - The original natural color blends well with almost any wall construction aesthetic.
- Large size
  - DiversiTech's large SpeediChannel™ size is a full 6" channel — unlike competitors' products which are only 5-1/2".
- Tight fit corner and flat bottom channel design
  - The flat bottom channel sits on surfaces easier and fits into corners better. It can be silicone sealed against the wall.
- Stainless steel screws
  - Stainless steel screws will not rust.
- Flat wall escutcheon
  - Competitive products have a larger escutcheon that is not aesthetically pleasing and wastes space.
- Integrated flex joint
  - Competitive products require a joiner piece to couple the flex joint to their systems. The DiversiTech flex joint slides right into the end of the SpeediChannel™ with no additional joiner piece.
- Long radius 90° bend
  - DiversiTech's long radius 90° bend allows for a larger bending radius for the line set, making installation easier.

## Features and Benefits

- Single piece wall sleeve • Competitive products are multi-part which is cumbersome.
- 20mm drain line with double connections • Versatile — fits 16, 18, or 20mm drain line.
- True Y connection • Drainline Y is inline. It does not branch.
- English packaging • Competitive products have Japanese on the boxes, potentially leading to product selection errors.

## Painting Specifications

DiversiTech recommends any 100% acrylic latex or 100% acrylic latex with a urethane additive when painting SpeediChannel products. The reason for this recommendation is because of the paint's flexibility. Lacquers are not recommended with PVC products because lacquers are more brittle and won't flex with the channel. Some suggestions: Duration by Sherwin Williams, Manor Hall paints by PPG and Moorelife by Benjamin Moore. In addition to paint type, only light-to-medium colored paints (Light Reflectance Value of 55% units or greater) should be applied to SpeediChannel or most any exterior PVC products. Light Reflectance Value (LRV) is a measurement that indicates how much light a color reflects. An LRV of 0% is absolute black and an LRV of 100% is perfectly reflective white. LRV is on the back of most color swatches and in the index of all major brands' fan decks. It is not safe to assume the paint is a light color. Some paints that appear light beige can have an LRV in the 20s or 30s.

## Step 1

Attach the SpeediChannel™ base to the wall about every 15 inches with screws suitable for the wall construction (siding, stucco, brick, etc.). Screw through the center of the molded rail. Slide the connecting piece (elbow, union, tee, etc.) under the SpeediChannel™ before attaching the end of the channel to the wall. When cutting lengths of SpeediChannel™, allow 1/8" gap between the end of the SpeediChannel™ and the stop inside the fitting to allow for thermal expansion.



## Step 2

Slide one SpeediClip™ with cable tie about every 20 inches along the inside sliding rail.



### Step 3

Install the line set, drain line, and wires inside the SpeediChannel™. Test the equipment installation prior to tightening the cable ties. Tighten the cable ties snug, but not so tight they damage the tubing insulation or kink the drain line. Trim excess length from the cable tie.





## Step 4

Attach the SpeediChannel™ to the base.



**Step 5**

Attach the fitting covers with the screws provided.



## Step 6

When complete, paint the SpeediChannel™ to match surface of installation (if desired).



## Typical Detail of Indoor Installation

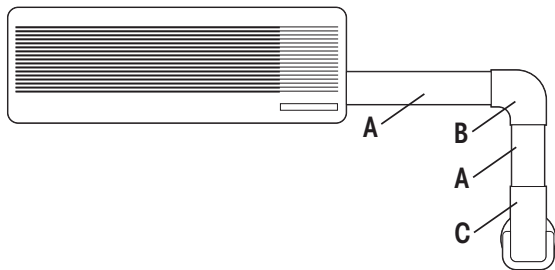

- A - 230-D
- B - 230-FB
- C - 230-WC
- D - 230-EB
- E - 230-EIN
- F - 230-DC
- G - 230-FJ
- H - 230-WS2

NOTE: Suffix parts  
A-G with the duct  
size needed (3, 4,  
or 6)

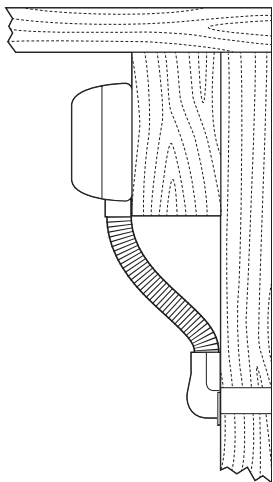
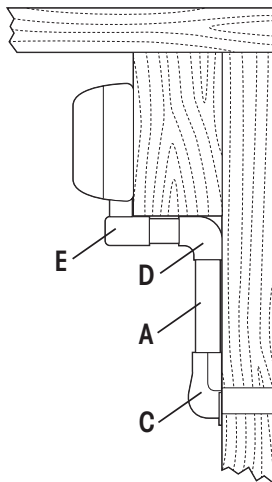

## Typical Detail of Outdoor Installation

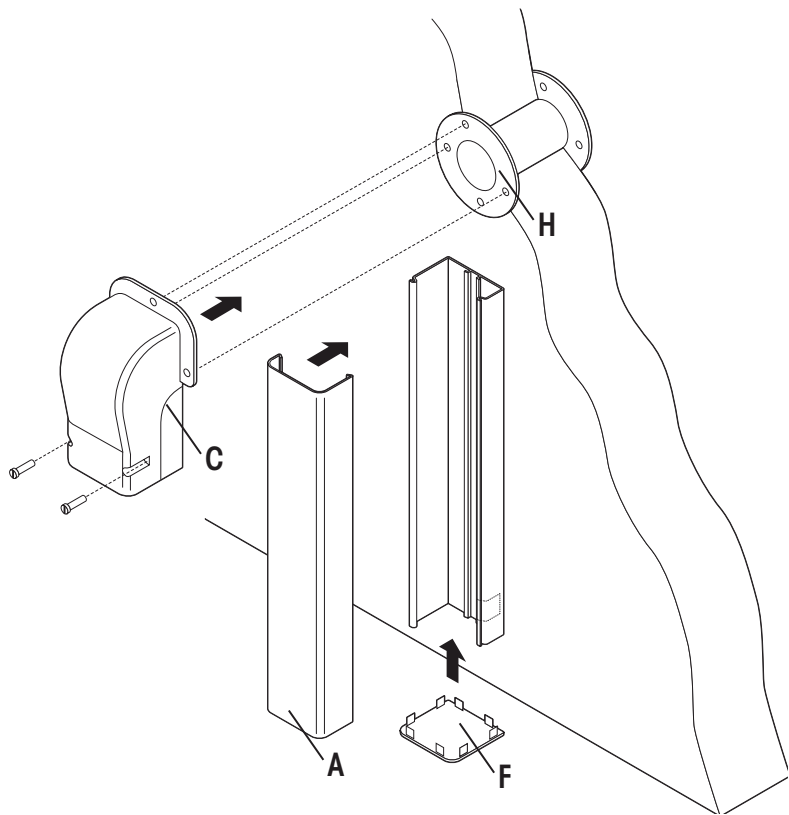

## Typical Detail of Flex Joint Application

- A - 230-D
- B - 230-FB
- C - 230-WC
- D - 230-EB
- E - 230-EIN
- F - 230-DC
- G - 230-FJ
- H - 230-WS2

NOTE: Suffix parts  
A-G with the duct  
size needed (3, 4,  
or 6)

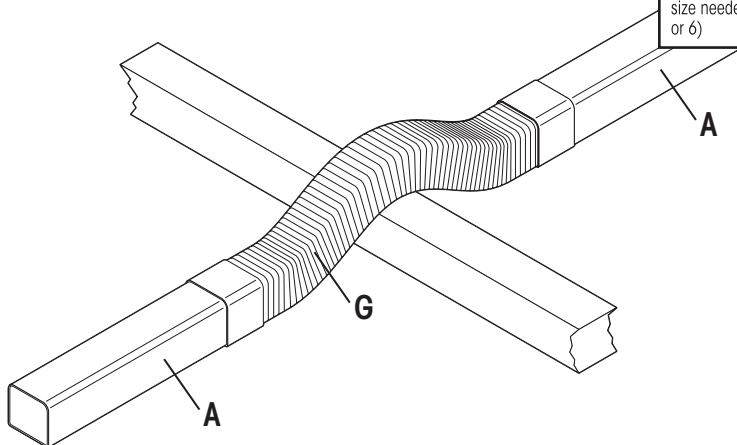

## Typical Detail of Cut-out for Drain Hose

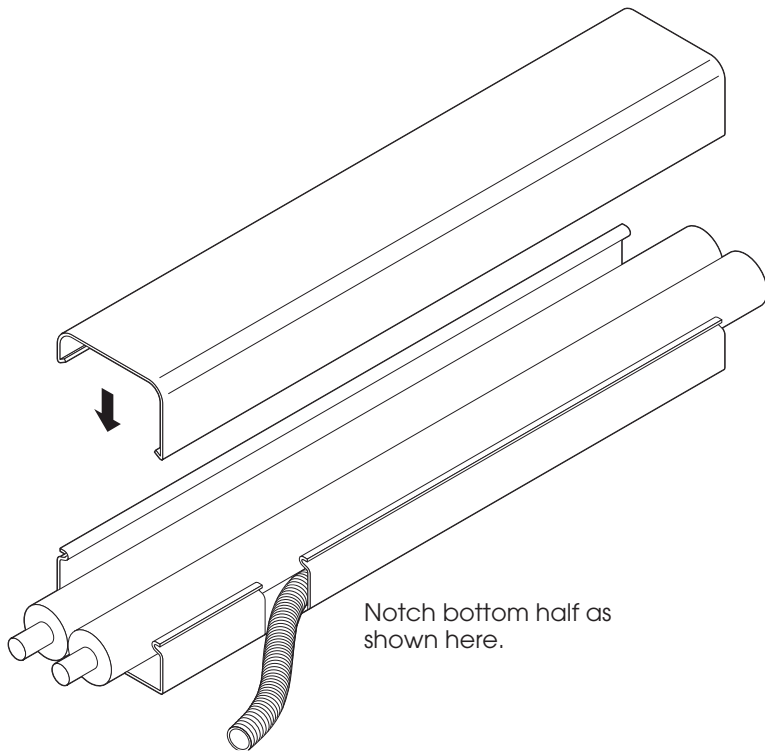

Notch bottom half as  
shown here.

## Typical Line Set, Cable, and Drain Hose Configuration

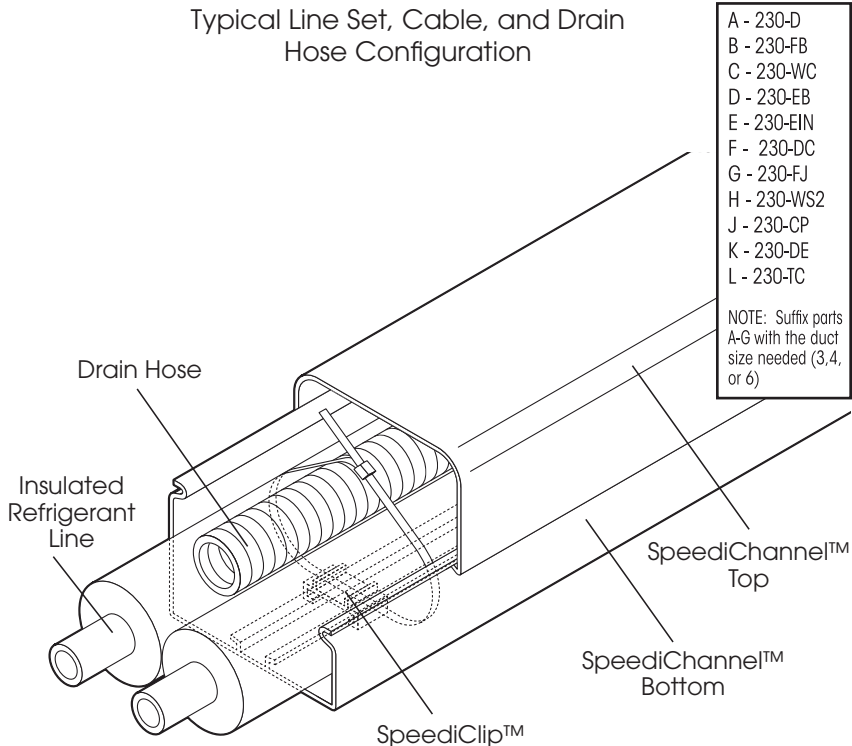



## Basic Application - 1 Air Handler

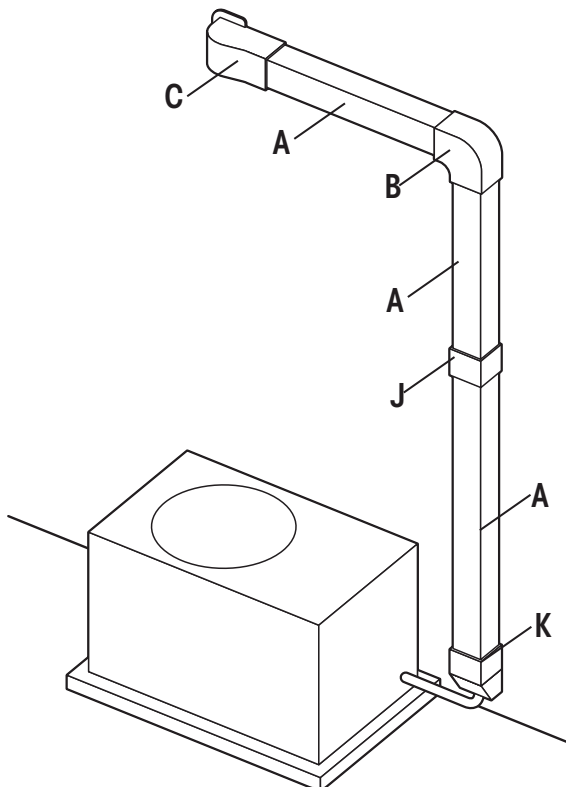

## Vertical Dual Air Handler System Application

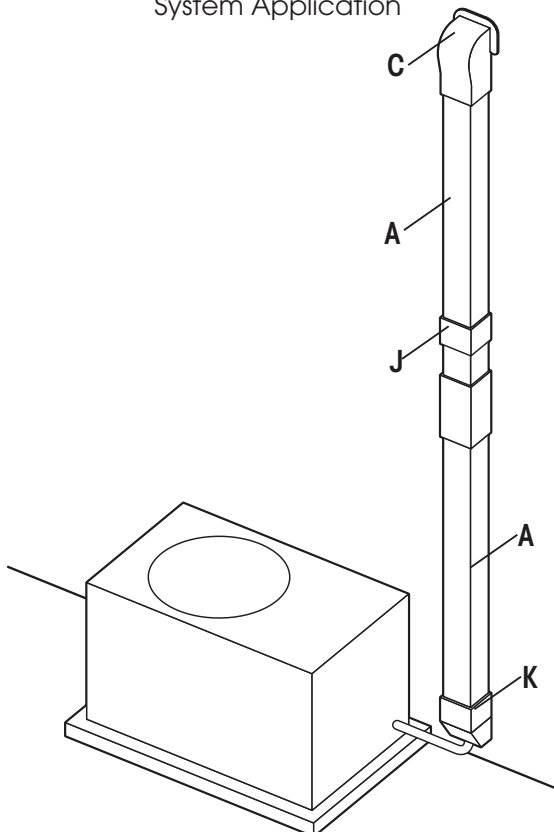

- A - 230-D
- B - 230-FB
- C - 230-WC
- D - 230-EB
- E - 230-EIN
- F - 230-DC
- G - 230-FJ
- H - 230-WS2
- J - 230-CP
- K - 230-DE
- L - 230-TC

NOTE: Suffix parts  
A-G with the duct  
size needed (3, 4,  
or 6)

# Horizontal Dual Air Handler System Application

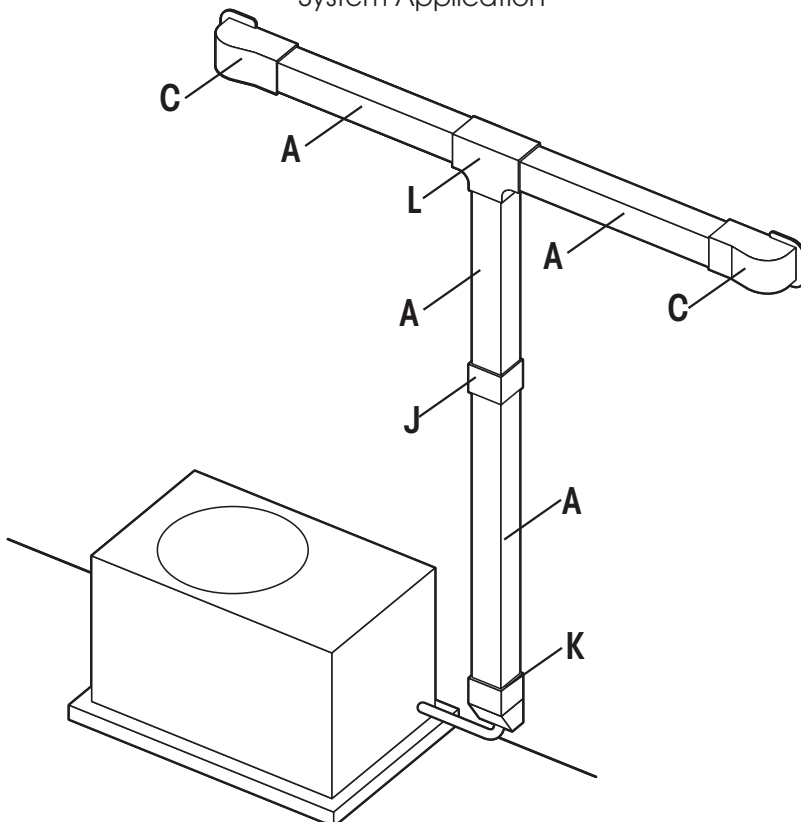

## Building with Different Wall Thickness Application

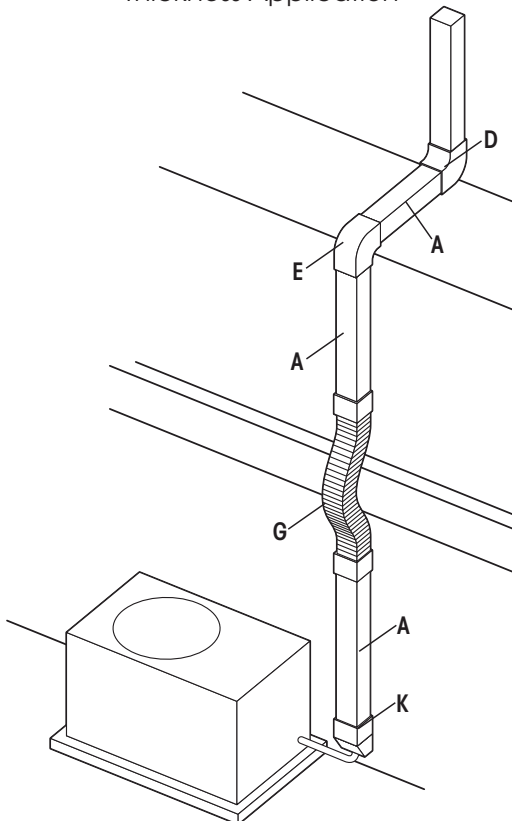

- A - 230-D
- B - 230-FB
- C - 230-WC
- D - 230-EB
- E - 230-EIN
- F - 230-DC
- G - 230-FJ
- H - 230-WS2
- J - 230-CP
- K - 230-DE
- L - 230-TC

NOTE: Suffix parts  
A-G with the duct  
size needed (3, 4,  
or 6)

## Sizing Chart and Selection Information

### Maximum Line Set, Drain Pipe, and Cable Capacity using 3/8" Insulation

Model	30-D32	30-D42	30-D6
Dimensions	3" x 2-1/2"	4" x 2-3/4"	6" x 3"
Length	39"	39"	39"

### Mini Split Systems – Liquid and Suction Line with 3/8" Insulation

Liquid Line	3/8"	2 x 1/4"	1 x 1/4" + 2 x 3/8"
Suction Line	5/8"	2 x 3/8"	1 x 1/2" + 2 x 5/8"
Drain Hose	3/4" OD	2 x 3/4" OD	3 x 3/4" OD
Power Cable	1 x UF 14-3	2 x 1/2" SealTite	3 x 1/2" SealTite
Control Cable	1 Pair 18 AWG	2 Pairs 18 AWG	3 Pairs 18 AWG
Nominal Tonnage	1–3 Tons	1x3 Ton or 2x1 Ton	1x3 Ton or 2x2 Ton

### Conventional Split Systems – Liquid Line Plain, Suction Line with 3/8" Insulation

Liquid Line	3/8"	3/8"	3/8"
Suction Line	3/4" or 7/8"	1-1/8"	1-1/8"
Drain Hose	3/4" PVC	3/4" PVC	3/4" PVC
Power Cable	1 x UF 14-2	1 x 1/2" SealTite	1 x 1/2" SealTite
Control Cable	1 Pair 18 AWG	1 Pair 18 AWG	1 Pair 18 AWG
Nominal Tonnage	Up to 3.5 Tons	4–5 Tons	7.5 Tons and up

## Technical Data

Color	Natural
Size	<b>230-D3:</b> 3" x 2-1/2" OD <b>230-D4:</b> 4" x 2-3/4" OD <b>230-D6:</b> 6" x 3-1/8" OD <b>Standard Length:</b> 39"
Material	Weather Resistant PVC, UV Stabilized and Fire Resistant
Fire Rating	Meets UL 94V-0
Temperature Range	4°F TO 140°F
Weather Resistance	Tested to over 2,000 hours
Fixing Screws	Stainless Steel

# SpeediChannel™

CATALOG NO.	DESCRIPTION	QTY. NEEDED
2 30-D3	3" SpeediChannel™ – 3-1/4' long	
2 30-D4	4" SpeediChannel™ – 3-1/4' long	
2 30-D6	6" SpeediChannel™ – 3-1/4' long	

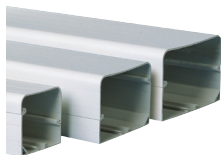

## Wall Penetration

CATALOG NO.	DESCRIPTION	QTY. NEEDED
2 30-WC3	3" Wall Penetration	
2 30-WC4	4" Wall Penetration	
2 30-WC6	6" Wall Penetration	
2 30-WS2	2-1/2" Wall Sleeve	



## Union Coupling

CATALOG NO.	DESCRIPTION	QTY. NEEDED
2 30-CP3	3" Union Coupling	
2 30-CP4	4" Union Coupling	
2 30-CP6	6" Union Coupling	

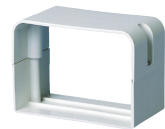

## 90° Long Radius Flat Bend

CATALOG NO.	DESCRIPTION	QTY. NEEDED
2 30-LFB3	3" 90 deg Long Radius Flat Bend	
2 30-LFB4	4" 90 deg Long Radius Flat Bend	
2 30-LFB6	6" 90 deg Long Radius Flat Bend	



## 90° Flat Bend

CATALOG NO.	DESCRIPTION	QTY. NEEDED
2 30-FB3	3" 90 deg Flat Bend	
2 30-FB4	4" 90 deg Flat Bend	
2 30-FB6	6" 90 deg Flat Bend	



## 90° Inside Elbow

CATALOG NO.	DESCRIPTION	QTY. NEEDED
2 30-EB3	3" 90 degree Inside Elbow	
2 30-EB4	4" 90 degree Inside Elbow	
2 30-EB6	6" 90 degree Inside Elbow	



## 90° Outside Elbow

CATALOG NO.	DESCRIPTION	QTY. NEEDED
2 30-EIN3	3" 90 degree Outside Elbow	
2 30-EIN4	4" 90 degree Outside Elbow	
2 30-EIN6	6" 90 degree Outside Elbow	



## 45° Flat Bend

CATALOG NO.	DESCRIPTION	QTY. NEEDED
2 30-FB453	3" 45 degree Flat Bend	
2 30-FB454	4" 45 degree Flat Bend	
2 30-FB456	6" 45 degree Flat Bend	



## T-Joint

CATALOG NO.	DESCRIPTION	QTY. NEEDED
2 30-TJ4	4" T-Joint	
2 30-TJ6	6" T-Joint	

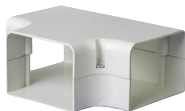

## Reducer Coupling

CATALOG NO.	DESCRIPTION	QTY. NEEDED
2 30-TC34	3" x 4" Reducer Coupling	
2 30-TC46	4" x 6" Reducer Coupling	





## Flex Joint

CATALOG NO.	DESCRIPTION	QTY. NEEDED
230-FJ3	3" Flex Joint	
230-FJ4	4" Flex Joint	

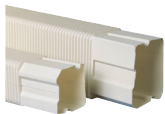

## Duct End

CATALOG NO.	DESCRIPTION	QTY. NEEDED
230-DE3	3" Duct End	
230-DE4	4" Duct End	
230-DE6	6" Duct End	



## Cap

CATALOG NO.	DESCRIPTION	QTY. NEEDED
230-DC3	3" Cap	
230-DC4	4" Cap	
230-DC6	6" Cap	



## Flat Wall Escutcheon

CATALOG NO.	DESCRIPTION	QTY. NEEDED
230-FR3	3" Flat Wall Escutcheon	
230-FR4	4" Flat Wall Escutcheon	
230-FR6	6" Flat Wall Escutcheon	



## Wall Escutcheon

CATALOG NO.	DESCRIPTION	QTY. NEEDED
230-WR3	3" Wall Escutcheon	
230-WR4	4" Wall Escutcheon	
230-WR6	6" Wall Escutcheon	



## Mounting Blocks

CATALOG NO.	DESCRIPTION	QTY. NEEDED
230-MB14W	14" MountBlock (White) pack of 2	
230-MB17W	17" MountBlock (White) pack of 2	
230-MB36W	36" MountBlock (White) pack of 2	
230-MBCW	MountBlock End Cap (White) pack of 4	

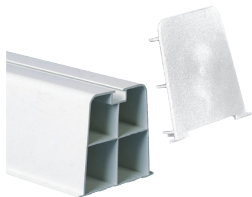

## Condensate Drain Pans

CATALOG NO.	DESCRIPTION	QTY. NEEDED
230-DPPL	Poly Cond Drain Pan (Large)	
230-DPML	Metal Cond Drain Pan (Large)	
230-DPPM	Poly Cond Drain Pan (Medium)	
230-DPMM	Metal Cond Drain Pan (Medium)	



## UltraLite® Equipment Pads

CATALOG NO.	DESCRIPTION	QTY. NEEDED
UC1636-2	16" x 36" x 2" UltraLite® Equipment Pad	
UC1636-3	16" x 36" x 3" UltraLite® Equipment Pad	
UC2448-2	24" x 48" x 2" UltraLite® Equipment Pad	

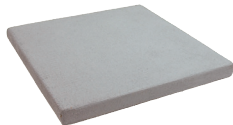

## E Lite® Equipment Pads

CATALOG NO.	DESCRIPTION	QTY. NEEDED
EL1838-3	18" x 38" x 3" E Lite® Equipment Pad	

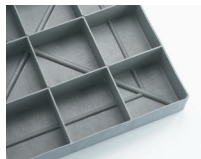

## CladLite® Equipment Pads

CATALOG NO.	DESCRIPTION	QTY. NEEDED
1636-2	16" x 36" x 2" CladLite® Equipment Pad	
1636-3	16" x 36" x 3" CladLite® Equipment Pad	

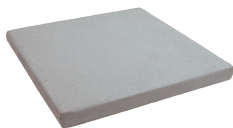

## Type 2 Wall Brackets

CATALOG NO.	DESCRIPTION	QTY. NEEDED
230-B2L	Type 2 Wall Brackets (Large)	
230-B2M	Type 2 Wall Brackets (Medium)	
Arm Length	21" (Large), 18" (Medium)	
Load Rating per Arm	220 lbs. (Large), 165 lbs. (Medium)	



## Type 3 Wall Brackets

CATALOG NO.	DESCRIPTION	QTY. NEEDED
230-B3L	Type 3 Wall Brackets (Large)	
230-B3M	Type 3 Wall Brackets (Medium)	
Arm Length	21" (Large), 19" (Medium)	
Load Rating per Arm	150 lbs. (Large), 100 lbs. (Medium)	





6650 Sugarloaf Parkway  
Duluth, GA 30097

**678.542.3600**  
**800.995.2222**  
**678.542.3700 Fax**



## About DiversiTech

DiversiTech Corporation is North America's largest manufacturer of equipment pads and a leading manufacturer and supplier of components and related products for the heating, ventilating, air conditioning, and refrigeration (HVACR) industry.

Headquartered in the Atlanta, GA metropolitan area, DiversiTech manufactures a suite of products which includes a wide range of mechanical, electrical, chemical, and structural parts for HVACR and electrical systems, and swimming pool installations. The company maintains manufacturing and distribution facilities in key U.S. locations, Europe, and in the Far East. DiversiTech has enjoyed a continued history of successful growth and has acquired industry-recognized names including Devco® Enterprises, Wagner® Manufacturing, The Black Pad®, Hef-T-Pad™, and Specialty Chemical.

Send edits / corrections / comments on this catalog to [feedback@diversitech.com](mailto:feedback@diversitech.com)