

SUBMITTAL DATA SHEET

Ceiling&Floor Heat Pump System BXALA60FC0-BXL2A60UC0

Location:	Approval:
Engineer:	Date:
Submitted to:	Construction:
Submitted by:	Unit #:
Reference:	Drawing #:



INDOOR SPECIFICATION

Indoor Air Flow (Turbo/H/M/L/Si) (CFM)		1365.6 / 1236.1 / 1118.3 / 882.9 / 777.0
Indoor Noise Level (Turbo/H/M/L/Si) (dBA)		N/A/54.5/49.0/42.0/39.0
Dimension (W×D×H)	inch	64.96 x 26.57 x 9.25
	mm	1650.0×675.0×235.0
Package (W×D×H)	inch	67.91 x 29.72 x 12.52
	mm	1725×755×318
Net/Gross Weight	lbs	95.24/111.33
	kg	43.2/50.5

OUTDOOR SPECIFICATION

Compressor Type	TWIN-ROTARY	
Compressor Model	EKPQ440D1UMUB	
Refrigerant	R454B	
Refrigerant Oil Charge(mL)	1300	
Refrigerant Oil	VG75	
Outdoor Air Flow (Max) (CFM)	4237.9	
Outdoor Noise Level (dBA)	64.5	
Dimension (W×D×H)	inch	37.48 x 16.34 x 52.48
	mm	952.0×415.0×1333.0
Package (W×D×H)	inch	43.11 x 19.49 x 58.27
	mm	1095×495×1480
Net/Gross Weight	lbs	230.38/261.69
	kg	104.5/118.7

EFFICIENCY

Cooling		Heating	
SEER2	18	HSPF2-4	10.7
EER2	9.0	COP	3.02

PERFORMANCE of Cooling

Cooling (Btu/hr)	
Rated Capacity	54000
Min/Max Capacity	20000~54500
Moisture Removal(L/h)	7.16
Standard Operating Range(°F/°C)	-22~122(-30~50)
Conditions:	Indoor: 80°F DB/67°F WB Outdoor: 95°F DB/75°F WB

PERFORMANCE of Heating

Heating (Btu/hr)	
1. @ 47°F Rated	60000
1. @ 47°F Min/Max Capacity	21700~65500
2. @ 17°F Rated	41000
3. @ 5°F Rated: Capacity / COP	54000/1.91
3. @ 5°F Max: Capacity	54000
Standard Operating Range(°F/°C)	-22~75(-30~24)
1. Conditions:	Indoor: 70°F DB/60°F WB Outdoor: 47°F DB/43°F WB
2. Conditions:	Indoor: 70°F DB/60°F WB Outdoor: 17°F DB/15°F WB
3. Conditions	Indoor: 70°F DB/60°F WB Outdoor: 5°F DB/5°F WB

ELECTRICAL

Power Supply	208/230V,60Hz,1Ph
System MCA	44.00
Connection Wiring	14#x3
System MOCP	45
Compressor RLA	26.8
Outdoor Fan Motor RLA	2.2
Outdoor Fan Motor W	85
Indoor Fan Motor RLA	2.0
Indoor Fan Motor W	160
System Power Input @ Cooling (W)	6000(2000 ~ 5900)
System Power Input @ Heating (W)	5823(1240 ~6000)
MCA: Min. circuit amps (A)	MOCP: Max. over current protection (A)
RLA: Rated load amps (A)	W: Fan motor rated output (W)

PIPING

Throttle type(Indoor)	N/A
Throttle type(Outdoor)	EXV+Throttle valve
Liquid Size	9.52mm(3/8in)
Gas Size	19mm(3/4in)
Max. Piping Length(ft/m)	246.00(75)
Max. Height Difference(ft/m)	98.40(30)
Max. Pre-charged Length(ft/m)	24.6(7.5)
Refrigerant Pre-charged Amount(oz/kg)	151.68(4.30)
Additional Charge of Refrigerant(oz/ft)/(g/m)	0.32(30)
Connection Method	Flared

Indoor Unit Dimension

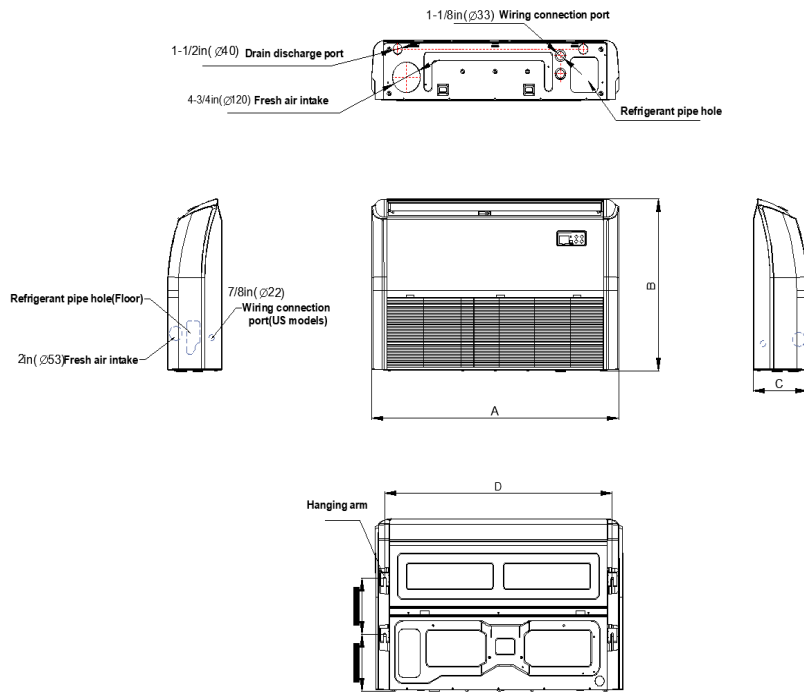

Model	A	B	C	D
18K/24K	42in(1068mm)	26-1/2in(675mm)	9-1/4in(235mm)	38-3/4in(983mm)
36K/48K/60K	65in(1650mm)	26-1/2in(675mm)	9-1/4in(235mm)	61-5/8in(1565mm)

Installation Instruction

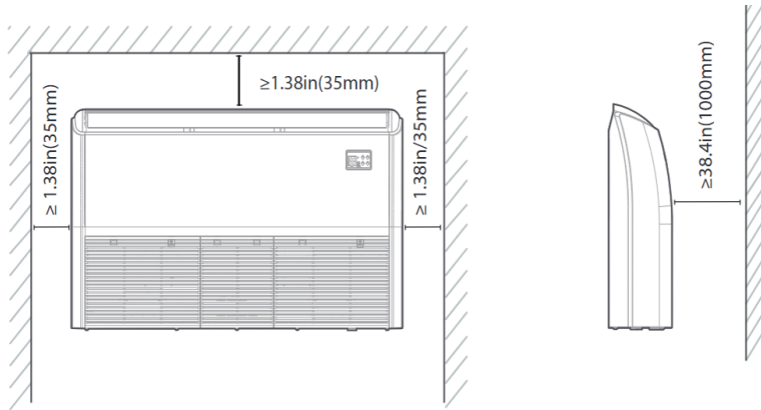

Outdoor Unit Dimension

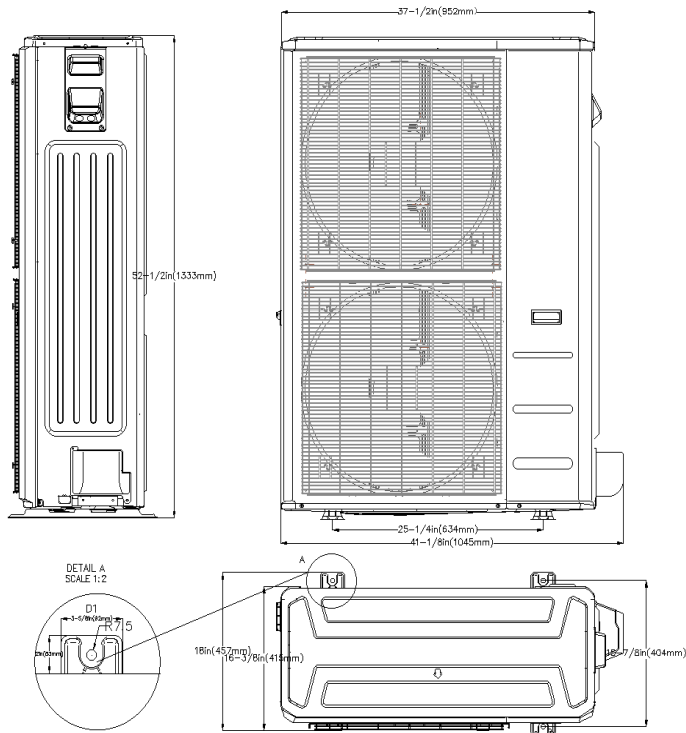

Installation Instruction

REQUIRED CLEARANCE

*1 20in. (500mm) or more when front and sides of the unit are clear

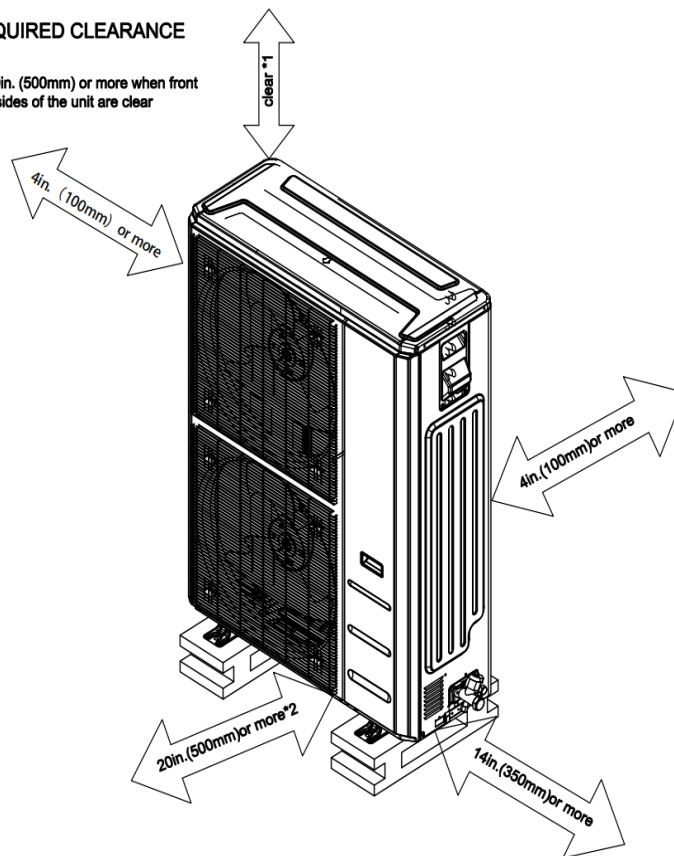

*2 When any 2 sides of left, right and rear of the unit are clear

FEATURES

- 2 Style Installation
- 3D Airflow
- Refrigerant leakage detection sensor
- Humidity sensor
- “88” display tube
- 1~100% fan speed setting
- WiFi capability: through WiFi dongle or wired controller with built-in WiFi
- OTA (by using WiFi dongle)
- 2-pin connector (HA/HB) for programmable wired controller
- Multiple control options available:
 - Two way communication wired controller: 120N(X6)
 - Two way communication wired controller with built-in WiFi: 120N(X6W)
 - Infrared wired controller: 120L
 - Wireless remote controller
 - Third-Party 24V Thermostat*

*24V interface is required.