

SUBMITTAL DATA SHEET

High Wall Heat Pump System BXS1A12WMV-BXS1A12SCV

Location:	Approval:
Engineer:	Date:
Submitted to:	Construction:
Submitted by:	Unit #:
Reference:	Drawing #:



INDOOR SPECIFICATION

Indoor Air Flow (Turbo/H/M/L/Si) (CFM)	312.0 / 312.0 / 241.3 / 176.6 / /	
Indoor Noise Level (Turbo/H/M/L/Si) (dBA)	//42/35/27/19	
Dimension (W×D×H)	inch	31.69 x 7.64 x 11.22
	mm	805.0×194.0×285.0
Package (W×D×H)	inch	34.25 x 10.63 x 14.37
	mm	870×270×365
Net/Gross Weight	lbs	17.64/22.71
	kg	8.0/10.3

OUTDOOR SPECIFICATION

Compressor Type	ROTARY	
Compressor Model	KSK103D33UEZ3	
Refrigerant	R454B	
Refrigerant Oil Charge(mL)	310	
Refrigerant Oil	VG74	
Outdoor Air Flow (Max) (CFM)	1058.8	
Outdoor Noise Level (dBA)	52.0	
Dimension (W×D×H)	inch	28.35 x 10.63 x 19.49
	mm	720.0×270.0×495.0
Package (W×D×H)	inch	32.87 x 11.81 x 21.26
	mm	835×300×540
Net/Gross Weight	lbs	53.79/58.42
	kg	24.4/26.5

EFFICIENCY

Cooling		Heating	
SEER2	19.0	HSPF2-4	9.2
EER2	8.8	COP	2.84

PERFORMANCE of Cooling

Cooling (Btu/hr)	
Rated Capacity	12000
Min/Max Capacity	3600~12500
Moisture Removal(L/h)	1.6
Standard Operating Range(°F/°C)	5~122(-15~50)
Conditions:	Indoor: 80°F DB/67°F WB Outdoor: 95°F DB/75°F WB

PERFORMANCE of Heating

Heating (Btu/hr)	
1. @ 47°F Rated	12000
1. @ 47°F Min/Max Capacity	3800~12400
2. @ 17°F Rated	7700
3. @ 5°F Rated: Capacity / COP	7000/2.20
3. @ 5°F Max: Capacity	7000
Standard Operating Range(°F/°C)	5~72(-15~24)
1. Conditions:	Indoor: 70°F DB/60°F WB Outdoor: 47°F DB/43°F WB
2. Conditions:	Indoor: 70°F DB/60°F WB Outdoor: 17°F DB/15°F WB
3. Conditions	Indoor: 70°F DB/60°F WB Outdoor: 5°F DB/5°F WB

ELECTRICAL

Power Supply	115V,60Hz,1Ph
System MCA	19.5
Connection Wiring	14#x4
System MOCP	20
Compressor RLA	14.3
Outdoor Fan Motor RLA	0.5
Outdoor Fan Motor W	34
Indoor Fan Motor RLA	0.6
Indoor Fan Motor W	15
System Power Input @ Cooling (W)	1364(305 ~ 1400)
System Power Input @ Heating (W)	1240(270 ~1255)
MCA: Min. circuit amps (A)	MOCP: Max. over current protection (A)
RLA: Rated load amps (A)	W: Fan motor rated output (W)

PIPING

Throttle type(Indoor)	N/A
Throttle type(Outdoor)	Capillary
Liquid Size	6.35mm(1/4in)
Gas Size	9.52mm(3/8in)
Max. Piping Length(ft/m)	82.00(25)
Max. Height Difference(ft/m)	49.20(15)
Max. Pre-charged Length(ft/m)	24.6(7.5)
Refrigerant Pre-charged Amount(oz/g)	20.46(0.58)
Additional Charge of Refrigerant((oz/ft)/(g/m))	0.16(15)
Connection Method	Flared

Indoor Unit Dimension

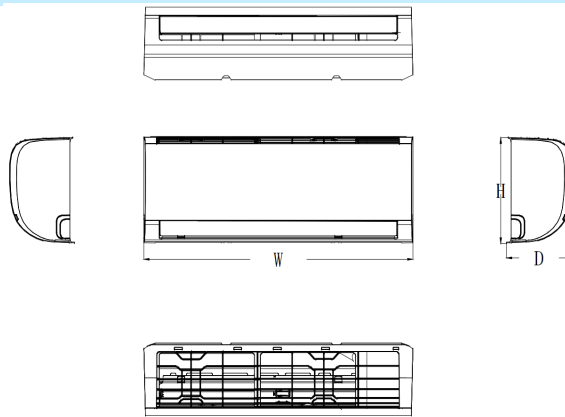

Capacity	Body Code	Unit	W	D	H
9k 115V	A	mm	715	194	285
		inch	28-1/8	7-5/8	11-1/4
9k-12k	B	mm	805	194	285
		inch	31-3/4	7-5/8	11-1/4
18k	C	mm	957	213	302
		inch	37-5/8	8-3/8	11-7/8
24k	D	mm	1040	220	327
		inch	41	8-5/8	12-7/8

Installation Instruction

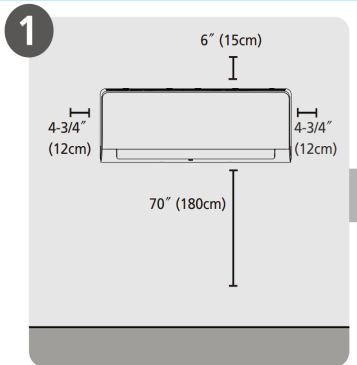

Select Installation Location

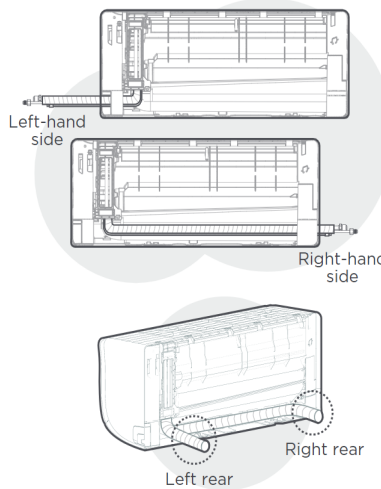

NOTE:
Based on the position of the wall hole relative to the mounting plate, choose the side from which the piping will exit the unit. You have four options for the exit direction of the piping.

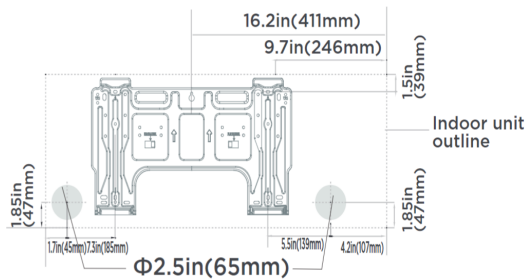

Indoor unit dimensions:
31.7in(805mm)x11.2in(285mm)

NOTE:
When the gas side connective pipe is Φ (5/8in)16mm or more, the wall hole should be (3-1/2in)90mm.

Outdoor Unit Dimension

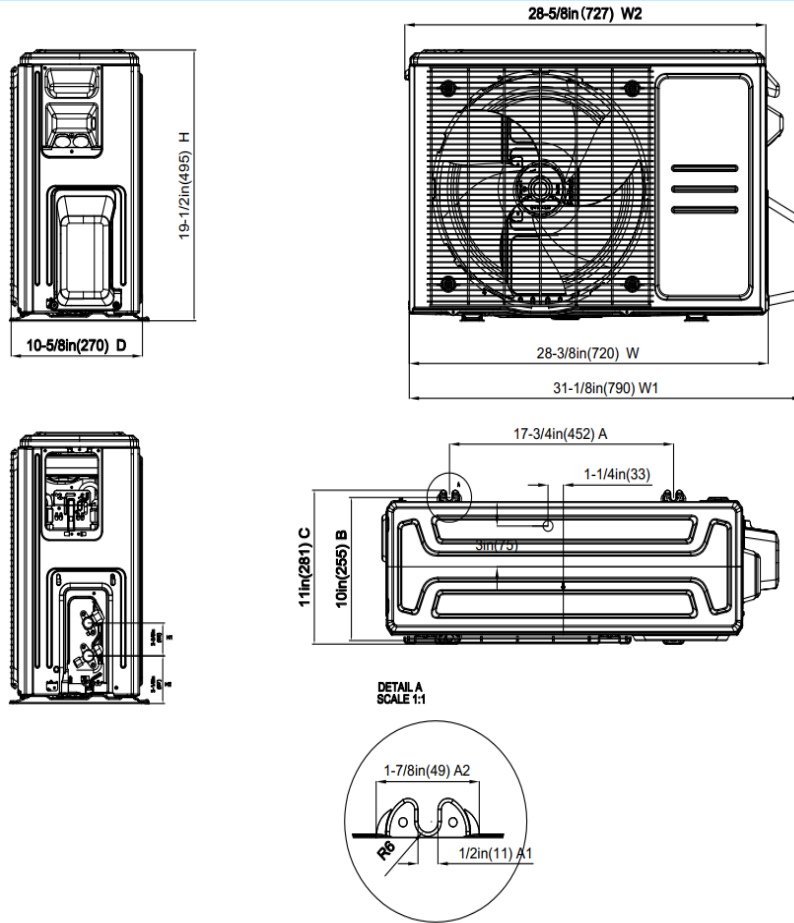

Installation Instruction

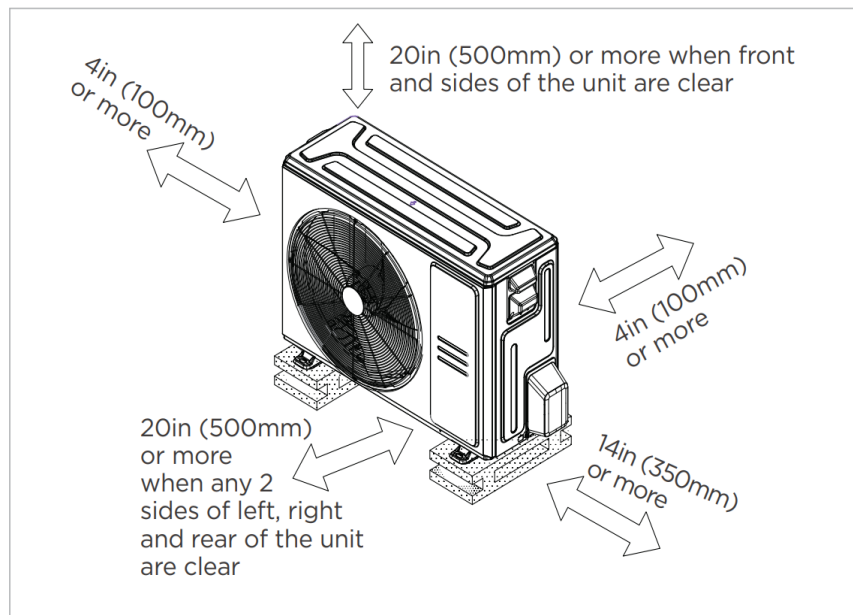

Meets all spatial requirements shown in Installation Clearance Requirements above.

FEATURES

- Indoor unit TU1 copper coil
- 1~100% fan speed setting
- WiFi capability: through WiFi dongle
- Multiple control options available:
 - Infrared wired controller: 120L
 - Wireless remote controller