

SUBMITTAL DATA SHEET

High Wall Heat Pump System BXAF18WM0-BXS5A18UC0

Location:	Approval:
Engineer:	Date:
Submitted to:	Construction:
Submitted by:	Unit #:
Reference:	Drawing #:



INDOOR SPECIFICATION

Indoor Air Flow (Turbo/H/M/L/Si) (CFM)	635.7 / 500.3 / 359.0 / 294.3 / /	
Indoor Noise Level (Turbo/H/M/L/Si) (dBA)	49.5/45.0/38.0/31.5/19.5	
Dimension (W×D×H)	inch	40.06x9.72x12.60
	mm	1017.4x248x319
Package (W×D×H)	inch	43.11x12.80x15.75
	mm	1095x325x400
Net/Gross Weight	lbs	27.34/36.60
	kg	12.4/16.6

OUTDOOR SPECIFICATION

Compressor Type	ROTARY	
Compressor Model	KTM240D46UKT2	
Refrigerant	R454B	
Refrigerant Oil Charge(mL)	620	
Refrigerant Oil	VG74	
Outdoor Air Flow (Max) (CFM)	1764.7	
Outdoor Noise Level (dBA)	59.0	
Dimension (W×D×H)	inch	35.04 x 13.46 x 26.50
	mm	890.0x342.0x673.0
Package (W×D×H)	inch	39.17 x 15.67 x 29.13
	mm	995x398x740
Net/Gross Weight	lbs	99.87/107.80
	kg	45.3/48.9

EFFICIENCY

Cooling		Heating	
SEER2	21.4	HSPF2-4	11.0
EER2	12.5	COP	3.26

PERFORMANCE of Cooling

Cooling (Btu/hr)	
Rated Capacity	18000
Min/Max Capacity	8800~19400
Moisture Removal(L/h)	9.1
Standard Operating Range(°F/°C)	-22~-122(-30~50)
Conditions:	Indoor: 80°F DB/67°F WB Outdoor: 95°F DB/75°F WB

PERFORMANCE of Heating

Heating (Btu/hr)	
1. @ 47°F Rated	18000
1. @ 47°F Min/Max Capacity	11200~19500
2. @ 17°F Rated	15000
3. @ 5°F Rated: Capacity / COP	18000/1.92
3. @ 5°F Max: Capacity	18000
Standard Operating Range(°F/°C)	-22~-75(-30~24)
1. Conditions:	Indoor: 70°F DB/60°F WB Outdoor: 47°F DB/43°F WB
2. Conditions:	Indoor: 70°F DB/60°F WB Outdoor: 17°F DB/15°F WB
3. Conditions	Indoor: 70°F DB/60°F WB Outdoor: 5°F DB/5°F WB

ELECTRICAL

Power Supply	208/230V,60Hz,1Ph	
System MCA	19.0	
Connection Wiring	14#x4	
System MOCP	20	
Compressor RLA	11.7	
Outdoor Fan Motor RLA	0.9	
Outdoor Fan Motor W	80	
Indoor Fan Motor RLA	0.8	
Indoor Fan Motor W	30	
System Power Input @ Cooling (W)	1440(230 ~ 1680)	
System Power Input @ Heating (W)	1618(770 ~2050)	
MCA: Min. circuit amps (A)	MOCP: Max. over current protection (A)	
RLA: Rated load amps (A)	W: Fan motor rated output (W)	

PIPING

Throttle type(Indoor)	N/A
Throttle type(Outdoor)	EXV+Throttle valve
Liquid Size	6.35mm(1/4in)
Gas Size	12.7mm(1/2in)
Max. Piping Length(ft/m)	98.40(30)
Max. Height Difference(ft/m)	65.60(20)
Max. Pre-charged Length(ft/m)	24.6(7.5)
Refrigerant Pre-charged Amount(oz/g)	55.38(1.57)
Additional Charge of Refrigerant((oz/ft)/(g/m))	0.16(15)
Connection Method	Flared

Indoor Unit Dimension

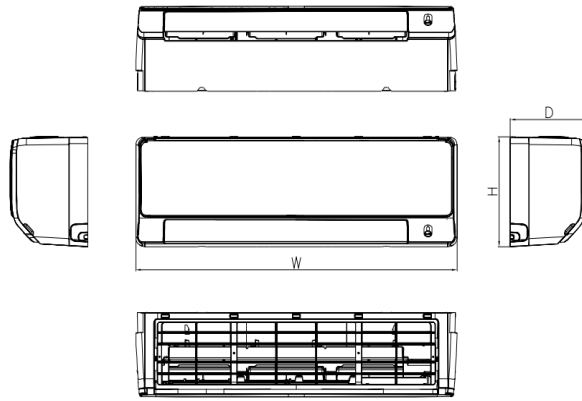

Capacity	Body Code	Unit	W	D	H
6k~12k	B	mm	848	233	300
		inch	33-3/8	9-1/8	11-3/4
18k~24k	C	mm	1017	248	319
		inch	40	9-3/4	12-1/2
24k~36k	D	mm	1190	285	371
		inch	46-7/8	11-1/4	14-5/8

Installation Instruction

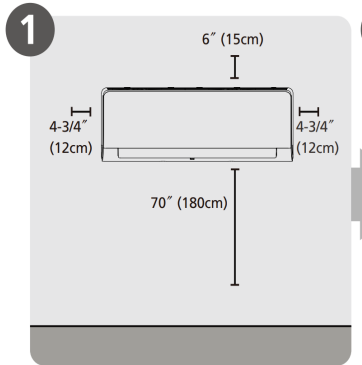

Select Installation Location

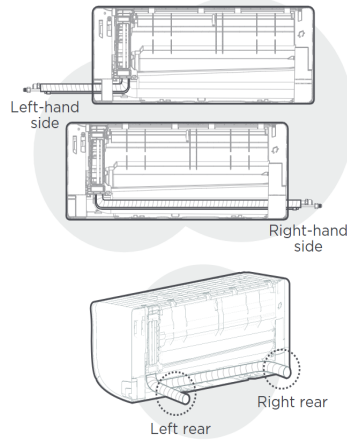

NOTE:
Based on the position of the wall hole relative to the mounting plate, choose the side from which the piping will exit the unit. You have four options for the exit direction of the piping.

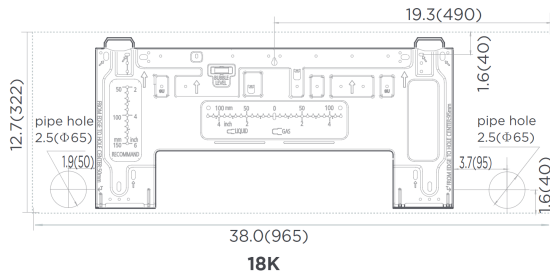

NOTE:
When the gas side connective pipe is Φ (5/8in)16mm or more, the wall hole should be (3-1/2in)90mm.

Outdoor Unit Dimension

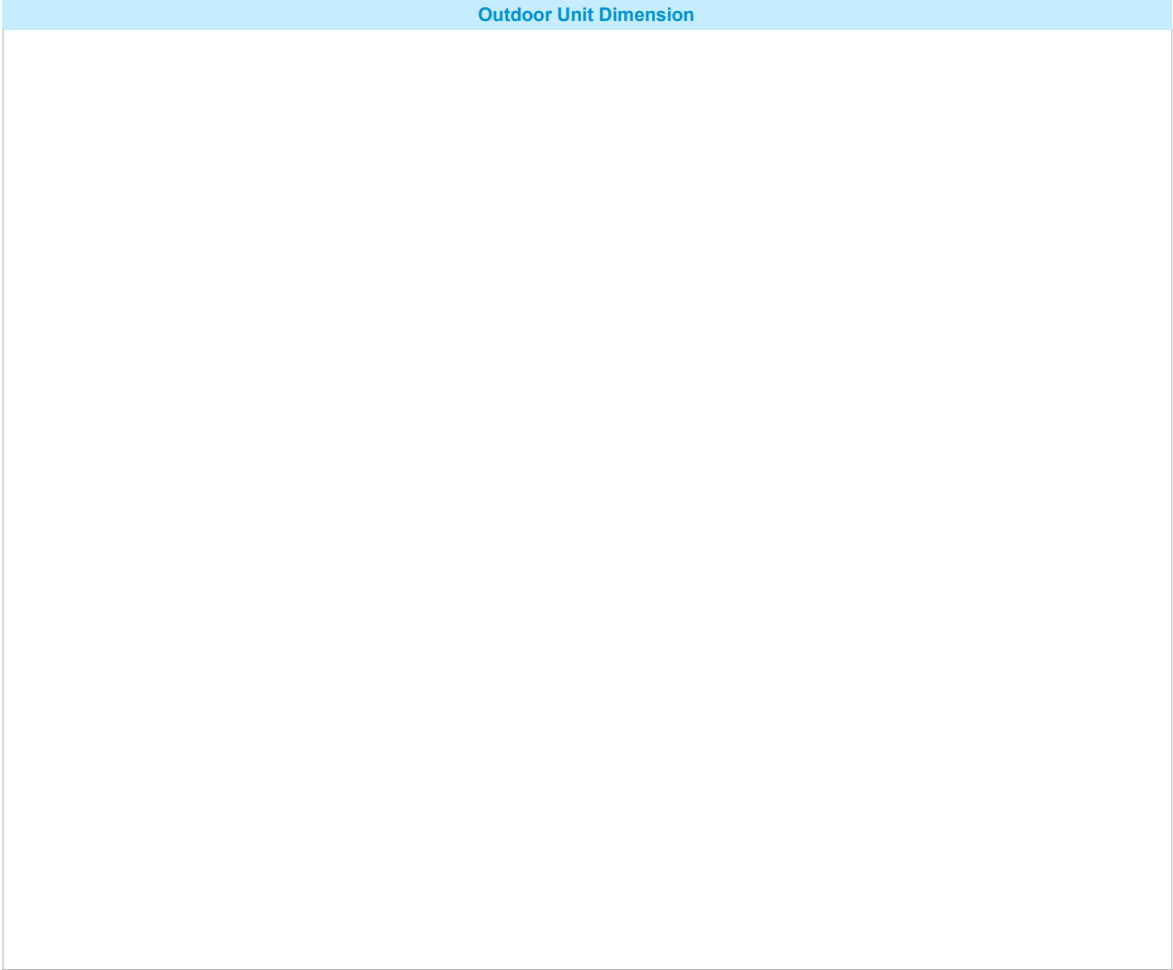

Installation Instruction

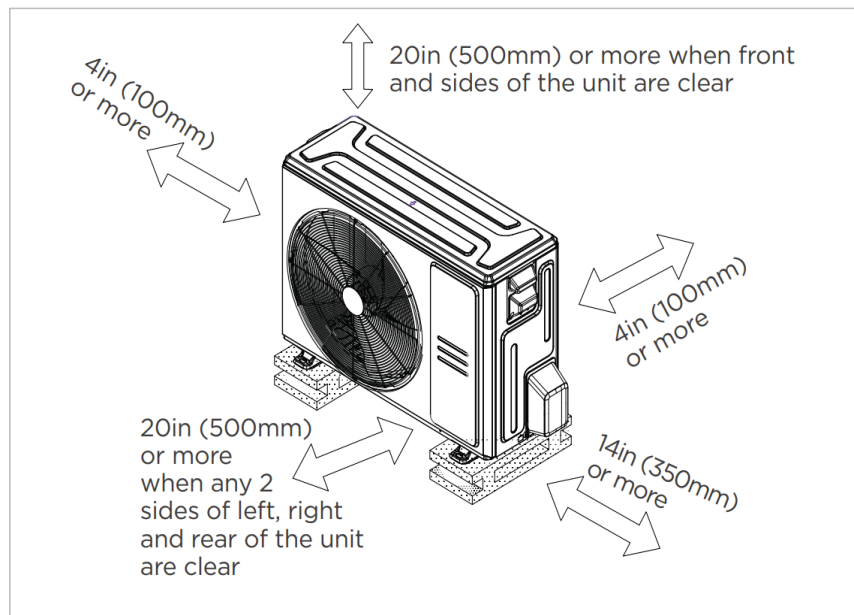

- Meets all spatial requirements shown in Installation Clearance Requirements above.

FEATURES

- Intelligent eye
- Easy maintenance design
- Indoor unit TU1 copper coil
- Humidity control
- 1~100% fan speed setting
- WiFi capability: through WiFi dongle or wired controller with built-in WiFi
- OTA(by using WiFi dongle)
- Multiple control options available:
 - Two way communication wired controller:120N(X6)
 - Two way communication wired controller with built-in WiFi:120N(X6W)
 - Infrared wired controller: 120L
 - Wireless remote controller
 - Third-Party 24V Thermostat*

*24V interface is required.