

# SUBMITTAL DATA SHEET

## High Wall Heat Pump System

Location:	Approval:
Engineer:	Date:
Submitted to:	Construction:
Submitted by:	Unit #:
Reference:	Drawing #:



### INDOOR SPECIFICATION

Indoor Air Flow (Turbo/H/M/L/Si) (CFM)	865.2 / 735.8 / 600.4 / 423.8 / /	
Indoor Noise Level (Turbo/H/M/L/Si) (dBA)	57.0/53.0/46.5/35.5/29.5	
Dimension (W×D×H)	inch	46.85x11.20x14.59
	mm	1190x285x371
Package (W×D×H)	inch	50.39x14.17x17.91
	mm	1280x360x455
Net/Gross Weight	lbs	43.21/55.78
	kg	19.6/25.3

### OUTDOOR SPECIFICATION

Compressor Type	TWIN-ROTARY	
Compressor Model	KTF420D62UNT	
Refrigerant	R454B	
Refrigerant Oil Charge(mL)	1000	
Refrigerant Oil	VG74	
Outdoor Air Flow (Max) (CFM)	2235.3	
Outdoor Noise Level (dBA)	63.5	
Dimension (W×D×H)	inch	37.24 x 16.14 x 31.89
	mm	946.0×410.0×810.0
Package (W×D×H)	inch	42.91 x 19.68 x 34.84
	mm	1090×500×885
Net/Gross Weight	lbs	156.97/167.99
	kg	71.2/76.2

### EFFICIENCY

Cooling		Heating	
SEER2	19.5	HSPF2-4	10.5
EER2	12.0	COP	3.37

### PERFORMANCE of Cooling

Cooling (Btu/hr)	
Rated Capacity	33000
Min/Max Capacity	15000~37000
Moisture Removal(L/h)	4.2
Standard Operating Range(°F/°C)	-22~122(-30~50)
Conditions:	Indoor: 80°F DB/67°F WB Outdoor: 95°F DB/75°F WB

### PERFORMANCE of Heating

Heating (Btu/hr)	
1. @ 47°F Rated	36000
1. @ 47°F Min/Max Capacity	19700~37800
2. @ 17°F Rated	30000
3. @ 5°F Rated: Capacity / COP	35000/1.98
3. @ 5°F Max: Capacity	35000
Standard Operating Range(°F/°C)	-22~75(-30~24)
1. Conditions:	Indoor: 70°F DB/60°F WB Outdoor: 47°F DB/43°F WB
2. Conditions:	Indoor: 70°F DB/60°F WB Outdoor: 17°F DB/15°F WB
3. Conditions:	Indoor: 70°F DB/60°F WB Outdoor: 5°F DB/5°F WB

### ELECTRICAL

Power Supply	208/230V,60Hz,1Ph	
System MCA	34.0	
Connection Wiring	14#x4	
System MOCP	35	
Compressor RLA	24.5	
Outdoor Fan Motor RLA	1.5	
Outdoor Fan Motor W	230	
Indoor Fan Motor RLA	1.6	
Indoor Fan Motor W	58	
System Power Input @ Cooling (W)	2750(440 ~ 3450)	
System Power Input @ Heating (W)	3131(1250 ~3970)	
MCA: Min. circuit amps (A)	MOCP: Max. over current protection (A)	
RLA: Rated load amps (A)	W: Fan motor rated output (W)	

### PIPING

Throttle type(Indoor)	N/A
Throttle type(Outdoor)	EXV
Liquid Size	9.52mm(3/8in)
Gas Size	19mm(3/4in)
Max. Piping Length(ft/m)	164.00(50)
Max. Height Difference(ft/m)	82.00(25)
Max. Pre-charged Length(ft/m)	24.6(7.5)
Refrigerant Pre-charged Amount(oz/g)	87.13(2.47)
Additional Charge of Refrigerant((oz/ft)/(g/m))	0.32(30)
Connection Method	Flared

### Indoor Unit Dimension

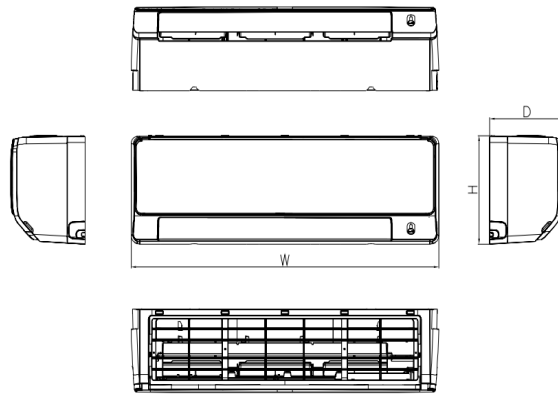

Capacity	Body Code	Unit	W	D	H
6k~12k	B	mm	848	233	300
		inch	33-3/8	9-1/8	11-3/4
18k~24k	C	mm	1017	248	319
		inch	40	9-3/4	12-1/2
24k~36k	D	mm	1190	285	371
		inch	46-7/8	11-1/4	14-5/8

### Installation Instruction

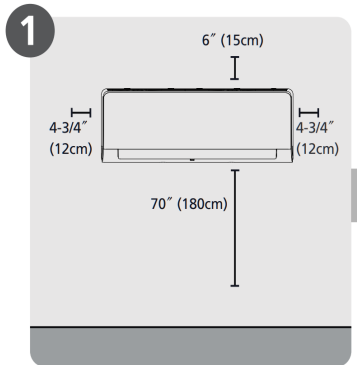

**1** Select Installation Location

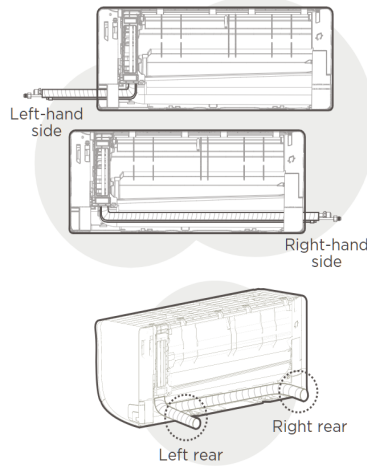

**NOTE:**  
Based on the position of the wall hole relative to the mounting plate, choose the side from which the piping will exit the unit. You have four options for the exit direction of the piping.

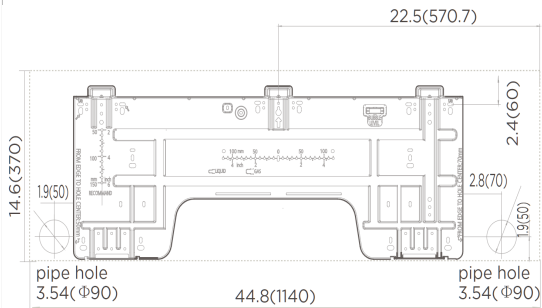

**NOTE:**  
When the gas side connective pipe is  $\Phi$  (5/8in)16mm or more, the wall hole should be (3-1/2in)90mm.

### Outdoor Unit Dimension

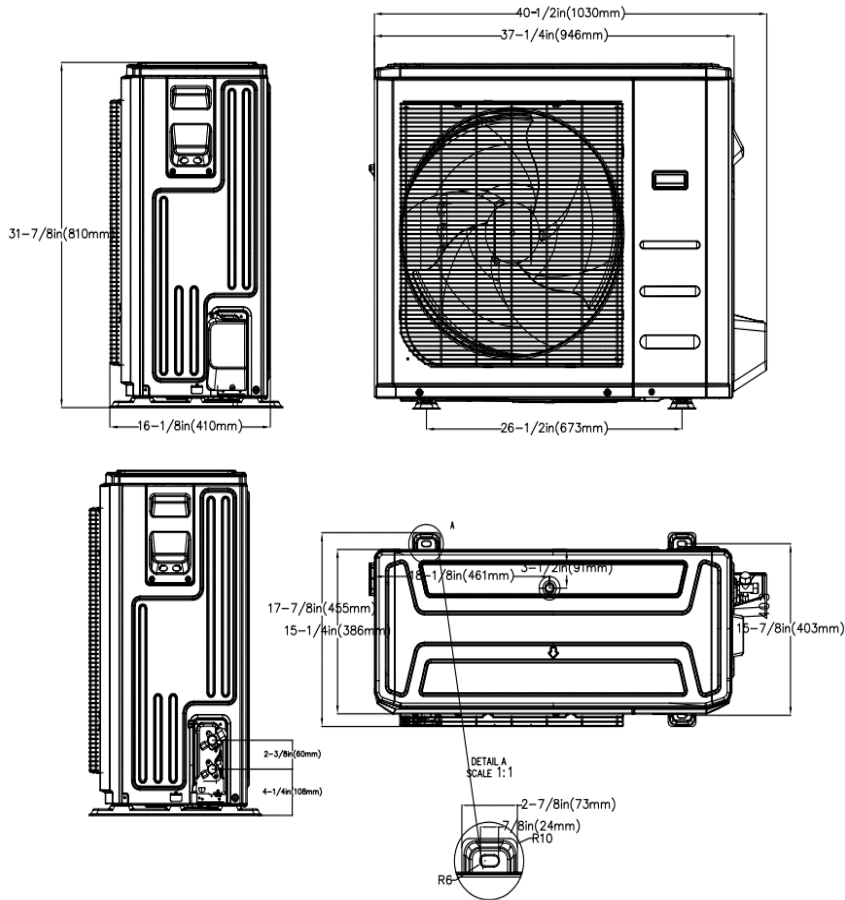

### Installation Instruction

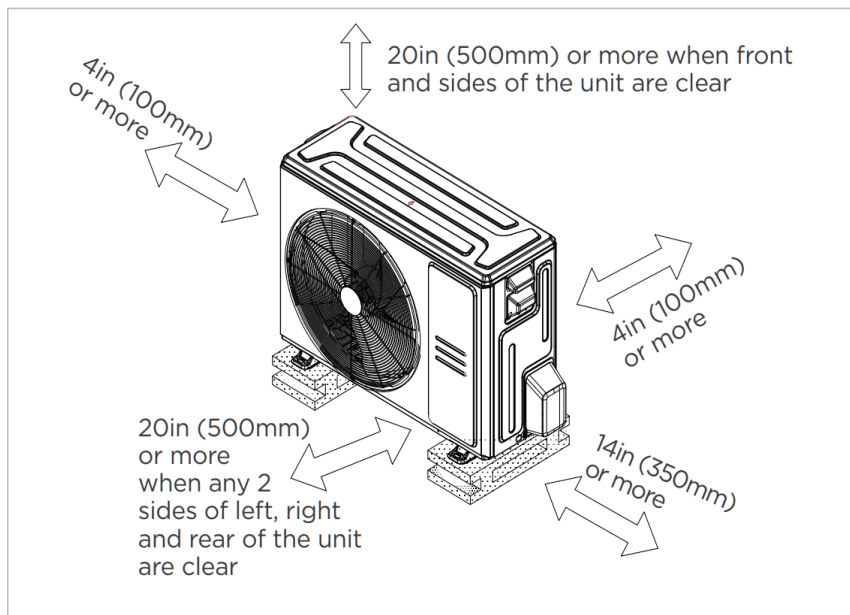

Meets all spatial requirements shown in Installation Clearance Requirements above.

## FEATURES

- Intelligent eye
- Easy maintenance design
- Indoor unit TU1 copper coil
- Humidity control
- 1~100% fan speed setting
- WiFi capability: through WiFi dongle or wired controller with built-in WiFi
- OTA(by using WiFi dongle)
- Multiple control options available:
  - Two way communication wired controller:120N(X6)
  - Two way communication wired controller with built-in WiFi:120N(X6W)
  - Infrared wired controller: 120L
  - Wireless remote controller
  - Third-Party 24V Thermostat\*

\*24V interface is required.